

**SD186ER**  
**Demonstration Board**  
**User's Manual**



## SD186ER Demonstration Board User's Manual, Release 1.2

© 1998 by Advanced Micro Devices, Inc.

All rights reserved. No part of this publication may be reproduced, stored in a retrieval system, or transmitted in any form or by any means, electronic, mechanical, photocopying, recording, or otherwise, without the prior written permission of Advanced Micro Devices, Inc.

Use, duplication, or disclosure by the Government is subject to restrictions as set forth in subdivision (b)(3)(ii) of the Rights in Technical Data and Computer Software clause at 252.227-7013. Advanced Micro Devices, Inc., 5204 E. Ben White Blvd., Austin, TX 78741.

AMD, the AMD logo, and combinations thereof, Am186, E86, and E86MON are trademarks, and FusionE86 is a service mark of Advanced Micro Devices, Inc.

Microsoft and Windows are registered trademarks of Microsoft Corp.

Other product names used in this publication are for identification purposes only and may be the trademarks of their respective companies.



---

# Contents

---

<b>About the SD186ER Demonstration Board</b>	<b>vii</b>
Theory of Operation .....	viii
Demonstration Board Features .....	viii
SD186ER Demonstration Board Documentation.....	x
About This Manual .....	x
Suggested Reference Material.....	xi
Documentation Conventions.....	xii

## Chapter 1

---

### Quick Start

Connecting to a PC.....	1-2
For More Information.....	1-6

## Chapter 2

---

### Demonstration Board Functional Description

Layout and Placement .....	2-2
Am186ER Microcontroller Implementation .....	2-4
ROM Space .....	2-6
RAM Space .....	2-6
RS-232 Serial Port.....	2-7

Clock and Reset Logic.....	2-8
Am186 Expansion Interface.....	2-8
PIO Activity LED Indicators.....	2-11
Power Supply.....	2-12

## Chapter 3

---

### Product Support

AMD Corporate Applications Technical Support Services.....	3-2
E-Mail Support.....	3-2
Online Support.....	3-2
Telephone and Fax Support.....	3-3
Product Support.....	3-4
WWW Site.....	3-4
FTP Site.....	3-5
Third-Party Development Support Products.....	3-5

1.2

## Appendix A

---

### Layout Diagram, Schematics, and Board Bill of Materials

Board Layout Diagram.....	A-2
Schematics.....	A-3
Board Bill of Materials (BOM).....	A-7

---

## Index

---

## List of Figures

Figure 0-1	SD186ER Demonstration Board Block Diagram .....	ix
Figure 2-1	SD186ER Demonstration Board Layout .....	2-3
Figure 2-2	Am186ER Microcontroller Block Diagram.....	2-5
Figure 2-3	DB-9 Serial Connector Pinout .....	2-7
Figure 2-4	Am186 Expansion Interface Pinout (J1).....	2-9
Figure 2-5	Am186 Expansion Interface Pinout (J3).....	2-10
Figure 2-6	Power Supply Polarity .....	2-12
Figure A-1	SD186ER Demonstration Board Layout .....	A-2

---

## List of Tables

Table 0-1.	Notational Conventions .....	xii
Table 1-1.	Installation Troubleshooting .....	1-5
Table 2-1.	SD186ER Demonstration Board Parts List.....	2-2
Table 2-2.	SD186ER Clock Modes .....	2-8
Table 2-3.	PIO LED Indicator Interface.....	2-11
Table A-1.	SD186ER Demonstration Board BOM.....	A-7



---

# About the SD186ER Demonstration Board

The AMD SD186ER Demonstration Board is designed as an exceptionally small, low-cost product for demonstration of the AMD Am186<sup>TM</sup>ER microcontroller. See page ix for a block diagram of the board.

The SD186ER demonstration board is a stand-alone evaluation platform for the Am186ER microcontroller. The Am186ER microcontroller integrates 32 Kbyte of RAM along with peripherals such as 13 chip-select controllers, one asynchronous serial port, one synchronous serial port, 32 programmable I/Os, three timers, an interrupt controller, and a hardware watchdog timer to increase system functionality while reducing overall cost. The memory controller supports a glueless connection to EPROM, Flash memory, pseudo-static RAM, and SRAM. The Am186ER microcontroller also features an innovative bus design that frees the processor to run at nearly twice the speed of standard 80C186 processors while using commodity memory devices.

The SD186ER demonstration board is designed with a 104-pin Am186 expansion interface that provides access to the Am186ER microcontroller signals. The Am186 expansion interface facilitates prototyping with external devices by using the SD186ER demonstration board as the minimal system core of a design.

The SD186ER demonstration board highlights the Am186ER microcontroller's asynchronous serial port, internal RAM, glueless interface to Flash memory, and expansion interface to peripheral attachments. A complete description of the board can be found in Chapter 2, "Demonstration Board Functional Description".

---

# Theory of Operation

The SD186ER demonstration board demonstrates the basic processor functionality and features of the Am186ER microcontroller, and the simplicity of its system design. As a stand-alone platform, the board enables you to test the Am186ER microcontroller's performance and functionality. The minimal number of components on the board exhibits the integration present in the processor.

---

## Demonstration Board Features

The SD186ER demonstration board provides the following features:

- Am186ER 50-MHz microcontroller
- E86™ family boot monitor (E86MON™) board-resident utility

Information on invoking and using the E86MON software is provided in the *E86MON™ Software User's Manual* provided in your kit.

- 256 Kbyte Am29F200-55 Flash memory
- Am186 104-pin expansion interface
- One RS-232 serial port with DB-9 connector
- Activity LED indicators for PIO signals
- Power-on LED indicator
- Reset circuitry

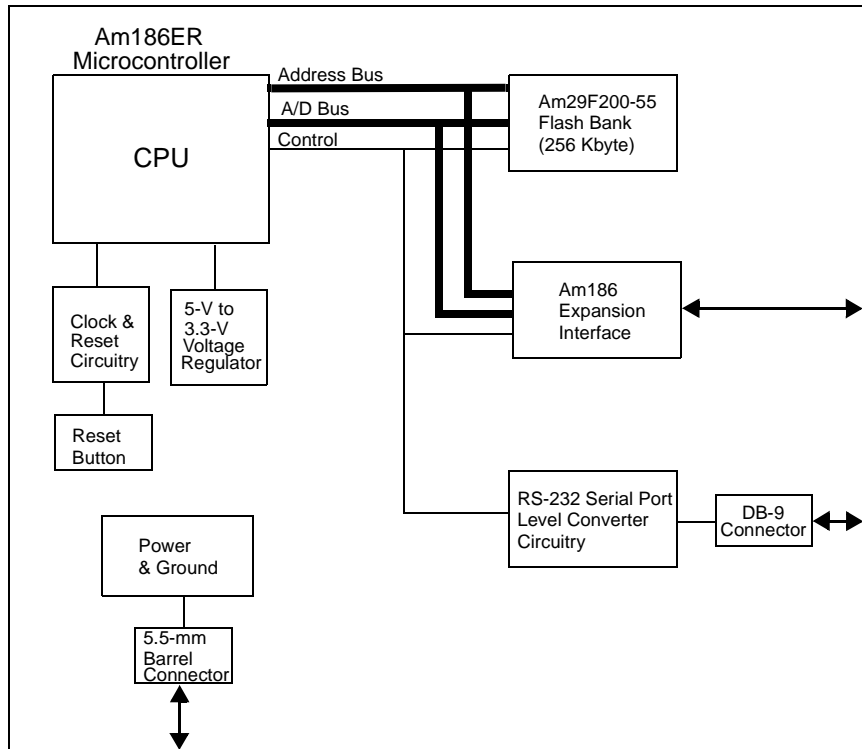

Figure 0-1. SD186ER Demonstration Board Block Diagram

---

# SD186ER Demonstration Board Documentation

The *SD186ER Demonstration Board User's Manual* provides information on the design and function of the SD186ER demonstration board. Detailed instructions for using the E86MON software are provided in the *E86MON™ Software User's Manual* included in your kit. The demonstration board is shipped with the E86MON software installed in the on-board Flash memory.

---

## About This Manual

Chapter 1, “Quick Start” provides implementation and installation information for the demonstration board and instructions for invoking the E86MON software. Detailed information on using the E86MON software is provided in the *E86MON™ Software User's Manual* included in your kit.

Chapter 2, “Demonstration Board Functional Description” contains descriptions of the basic sections of the demonstration board: layout, processor, Flash memory, serial ports, clock and reset logic, expansion interface, power and signal LED indicators, and power-supply circuitry.

Chapter 3, “Product Support” provides information on reaching and using the AMD Corporate Applications technical support services, product information available through AMD's World Wide Web and FTP sites, and support tools for the embedded E86 family.

Appendix A, “Layout Diagram, Schematics, and Board Bill of Materials” contains a board layout drawing along with schematics and a Bill of Materials (BOM) for the SD186ER demonstration board.

---

## Suggested Reference Material

For information on ordering the literature listed below, see Chapter 3, “Product Support”.

- *Am186<sup>TM</sup>ER and Am188<sup>TM</sup>ER Microcontrollers Data Sheet*  
Advanced Micro Devices, order number 20732
- *Am186<sup>TM</sup>ER and Am188<sup>TM</sup>ER Microcontrollers User’s Manual*  
Advanced Micro Devices, order number 21684
- *Am186<sup>TM</sup> and Am188<sup>TM</sup> Family Instruction Set Manual*  
Advanced Micro Devices, order number 21267
- *FusionE86<sup>SM</sup> Catalog*  
Advanced Micro Devices, order number 19255
- For current application notes and technical bulletins, see our World Wide Web page at <http://www.amd.com>.

---

## Documentation Conventions

The Advanced Micro Devices *SD186ER Demonstration Board User's Manual* uses the conventions shown in Table 0-1 (unless otherwise noted). These same conventions are used in all E86 family support product manuals.

**Table 0-1. Notational Conventions**

<b>Symbol</b>	<b>Usage</b>
<b>Boldface</b>	Indicates that characters must be entered exactly as shown, except that the alphabetic case is only significant when indicated.
Typewriter face	Indicates computer text input or output in an example or listing.

# Chapter 1



---

## Quick Start

This chapter provides information that will help you quickly set up and start using the SD186ER demonstration board.

The SD186ER demonstration board is supported by the E86MON software. The E86MON software enables you to load, run, and debug programs on the SD186ER demonstration board. For detailed information on using the E86MON software, refer to the *E86MON™ Software User's Manual* included in your kit.

For information on how to:

- Connect the SD186ER demonstration board to a PC, see page 1-2
- Invoke the E86MON software, see page 1-4
- Troubleshoot installation problems, see page 1-5
- Locate related sources of information, see page 1-6

---

# Connecting to a PC

Follow the steps below to connect the SD186ER demonstration board to your PC.

## Installation Requirements

The items listed below are necessary to install and run the SD186ER demonstration board:

- PC with an available COM port
- Terminal emulation software (such as Microsoft Windows® Terminal or ProComm Plus) that supports ASCII file transfers, software flow control (Xon/Xoff), and *send break* capability
- Power source for universal power supply

## Board Installation



**CAUTION: As with all computer equipment, the SD186ER demonstration board may be damaged by electrostatic discharge (ESD). Please take proper ESD precautions when handling any board.**

1. Remove the board from the shipping carton. Visually inspect the board to verify that it was not damaged during shipment.

2. Connect the demonstration board's DB-9 serial port to an available COM port. Use the serial cable included in the SD186ER demonstration board kit and note that a DB-9 to DB-25 serial connector adapter is provided if your host system requires it. The pinout of the demonstration board's serial connector is shown on page 2-7.

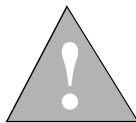
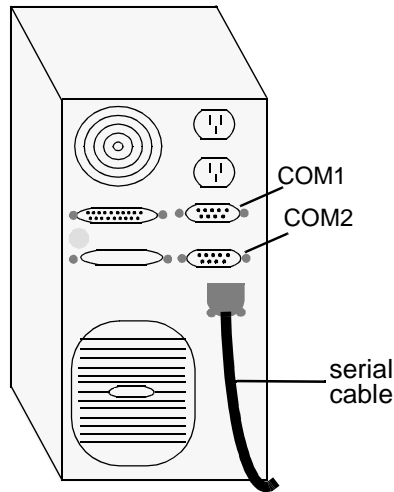

**DANGER:** Make sure the power supply is *not* plugged into an electrical outlet before connecting it to the SD186ER demonstration board.

3. Connect the power supply to the barrel connector on the SD186ER demonstration board.
4. Apply power to the board by connecting the power supply to an electrical outlet. Once the board is powered up, the LEDs (CR2–CR9) should flash in an oscillating pattern.



**CAUTION:** If using your own power supply, ensure that it is a 5-V supply. Using a 9-V supply will permanently damage the board. For more information, see “Power Supply” on page 2-12.

5. Invoke the terminal emulation program at 19200 baud, no parity, 8 data bits, and 1 stop bit; enable the software flow control (Xon/Xoff), if supported.

6. Reset the board by depressing and releasing the RESET switch (see location in Figure 2-1 on page 2-3). The LEDs on the board (CR2–CR9) will flash in an oscillating pattern for three seconds, as they did upon power up.

During the three-second period while the LEDs are oscillating, type an **a** in the terminal window to ensure that the E86MON software uses the correct baud rate. When the E86MON software receives an **a**, it adjusts its baud rate (if necessary) and displays the welcome message and prompt.

If you type a character other than an **a**, or type no character at all, the E86MON software still displays the welcome message and prompt, but may be using an incorrect baud rate. Depressing and releasing the RESET switch gives you another opportunity to type an **a**.

7. To display the version of the E86MON software and the commands available, type **?** and press Enter.

For detailed information about using the E86MON software, refer to the *E86MON™ Software User's Manual* included in your kit.

**Table 1-1. Installation Troubleshooting**

<b>Problem</b>	<b>Solution</b>
Nothing happens when pushing the RESET button.	Sometimes it is difficult to make a good connection when pushing the small RESET button. If all else fails, remove the power supply from the AC electrical outlet and disconnect and reconnect the power supply. The LEDs will flash in an oscillating pattern when the reset is successful.
The computer does not respond with the E86MON software prompt.	Reset the board by pressing the RESET switch and typing an <b>a</b> while the LEDs are flashing in an oscillating pattern. If this does not work, verify the power, check the cables, etc.
After typing <b>a</b> during reset, the terminal emulation software displays unreadable characters.	Check the baud rate setting for the terminal emulation software. It should be set to 19200. Also check the word length (8), stop bits (1), parity (N), and turn off any hardware flow control.
After a processor reset, the LEDs do not flash in the expected oscillating pattern.	Check that the power LED is on and the correct voltage is supplied to the board. Ensure that the polarity of the power connector is correct.
The terminal emulation program locks up the software or PC.	Check the COM port connection with the target board. Make sure that the same COM port is selected in the terminal emulation software. In some PCs if the correct COM port is not specified, the software will fail to function—it will lock in a continuous loop waiting for an answer from the incorrect serial port.
The power LED does not turn on with power.	Immediately disconnect the power supply. Ensure that the polarity of the power connector is correct. This is a very serious failure of the hardware. If the power source is connected incorrectly, the board will be permanently damaged.
There is a problem you cannot resolve.	Contact the AMD Corporate Applications technical support services (see Chapter 3, “Product Support” for phone numbers and more information).

---

## For More Information...

If you need more information about:

- SD186ER demonstration board hardware,  
see Chapter 2, “Demonstration Board Functional Description”
- The E86MON software,  
see the *E86MON™ Software User’s Manual*
- Problems with the board or the E86MON software,  
see Chapter 3, “Product Support”
- SD186ER demonstration board layout and schematics,  
see Appendix A, “Layout Diagram, Schematics, and Board Bill of Materials”
- The Am186ER microcontroller  
see the *Am186™ER and Am188™ER Microcontrollers Data Sheet* and the  
*Am186™ER and Am188™ER Microcontrollers User’s Manual*

# Chapter 2



---

## Demonstration Board Functional Description

The SD186ER demonstration board provides a completely stand-alone microcontroller-based evaluation platform in a low-cost, exceptionally small form-factor product. The SD186ER demonstration board was designed to meet the needs of customers working with the Am186ER microcontroller.

Read the following sections to learn more about the demonstration board hardware:

- “Layout and Placement” on page 2-2
- “Am186ER Microcontroller Implementation” on page 2-4
- “ROM Space” on page 2-6
- “RAM Space” on page 2-6
- “RS-232 Serial Port” on page 2-7
- “Clock and Reset Logic” on page 2-8
- “Am186 Expansion Interface” on page 2-8
- “PIO Activity LED Indicators” on page 2-11
- “Power Supply” on page 2-12

---

## Layout and Placement

The design of the SD186ER demonstration board emphasizes ease of use and small size. Refer to Figure 2-1 on page 2-3 for board layout and component placement.

The SD186ER demonstration board has the Flash memory device (U4) beside the processor. This placement keeps the memory device as close as possible to the processor to minimize noise and trace reflections. The 12.5-MHz fundamental mode crystal (Y1) is located to the left of the processor. The Am186 expansion interface (J1 and J3) is located at the bottom of the board for easy connection and access. Finally, the 5.5-mm power-supply barrel connector (J2) is positioned in the upper left corner of the board.

The RS-232 serial port has a DB-9 connector which is positioned in the upper right corner of the board (P1).

**Table 2-1. SD186ER Demonstration Board Parts List**

<b>Part Number</b>	<b>Description</b>	<b>For more information, see</b>
CR1–CR9	Power and signal LEDs	Page 2-11
J1, J3	Am186 expansion interface	Page 2-8
J2	Power connector	Page 2-12
P1	RS-232 serial port	Page 2-7
SW1	RESET switch	Page 2-8
U1	Voltage supply supervisor (TI TL7705ACD)	N/A
U2	Am186ER 50-MHz microcontroller	Page 2-4
U3	RS-232 driver/receiver device (MAX232)	Page 2-7
U4	Am29F200 Flash memory	Page 2-6
U5	3.3-V low dropout voltage regulator	Page 2-12
Y1	12.5-MHz fundamental mode crystal	Page 2-8

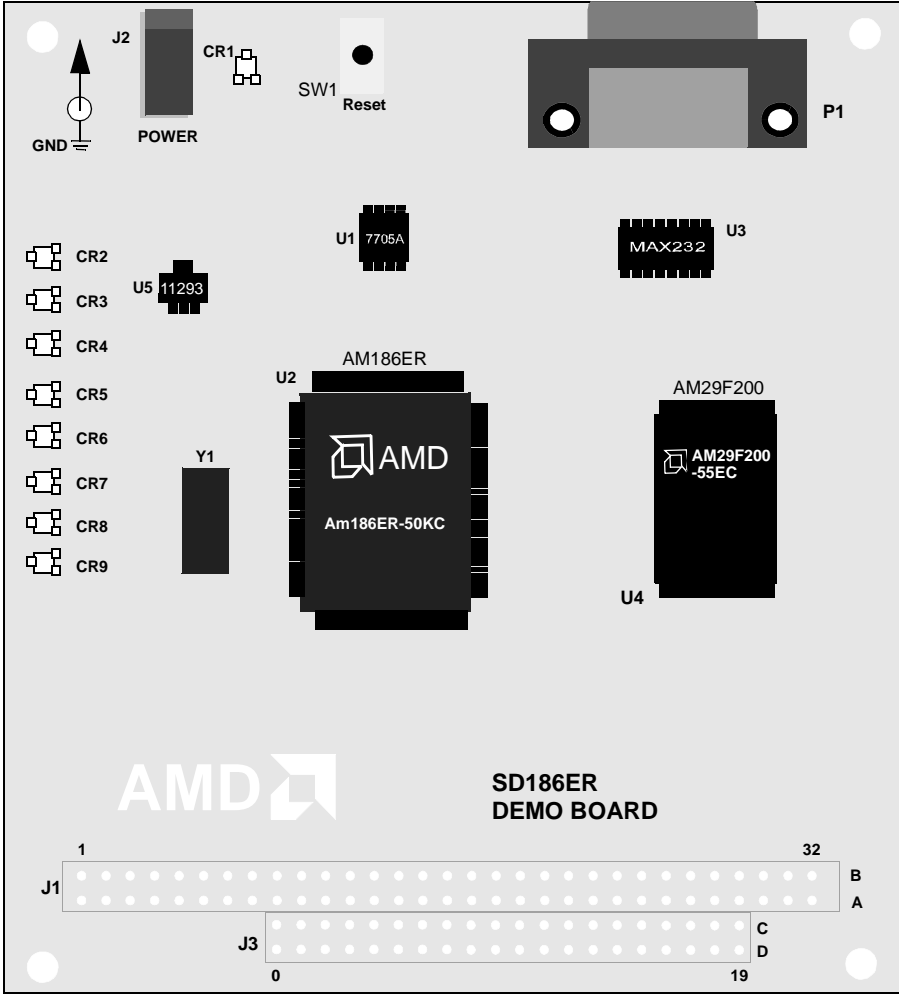

Figure 2-1. SD186ER Demonstration Board Layout

1.2

---

# Am186ER Microcontroller Implementation

The SD186ER demonstration board supports the AMD Am186ER microcontroller. The board is shipped with an Am186ER microcontroller that operates at 50 MHz. Although not supported by the on-board crystal, the Am186ER microcontroller is also available in 25-, 33-, and 40-MHz operating frequencies.

The Am186ER microcontroller is designed to meet the most common requirements of embedded products developed for the communications, office automation, mass storage, and general embedded markets. Specific applications include feature phones, cellular phones, PBXs, multiplexers, modems, disk drive controllers, hand-held and desktop terminals, fax machines, line cards, managed hubs, and industrial control. Refer to the *Am186<sup>TM</sup>ER and Am188<sup>TM</sup>ER Microcontrollers Data Sheet* for more information on the specific features.

See Figure 2-2 on page 2-5 for a block diagrams detailing the Am186ER microcontroller's functionality.



---

## ROM Space

The SD186ER demonstration board is populated with an Am29F200 256-Kbyte, 55-ns Flash memory device for use by the E86MON software and application code. The Am29F200 provides support for both 8- and 16-bit accesses.

The Flash memory device is mapped to the upper region of addressable memory at C0000h to FFFFFh. On the SD186ER demonstration board, the Flash memory device is configured as a 128K x 16-bit wide array. The Flash memory device has a nonsymmetrical sector configuration. Starting at the top of Flash memory, the sectors sizes are: 16 Kbyte, 8 Kbyte, 8 Kbyte, 32 Kbyte, 64 Kbyte, 64 Kbyte, and 64 Kbyte. The E86MON software only uses the top 16-Kbyte sector. The Flash memory device is connected to the  $\overline{UCS}$  (Upper Memory Chip Select) signal of the microcontroller. After a valid reset, the Am186ER microcontroller fetches the first instruction from the Flash memory device at address FFFF0h.

The E86MON software enables you to program the Flash memory device with specific types of hex files. Intel hex and Intel extended hex format files are supported. This software functionality is provided to eliminate the need to remove the Flash memory device for programming. Do not attempt to remove the TSOP Flash memory device (U4) because doing so may damage the board.

1.2

---

## RAM Space

The SD186ER demonstration board demonstrates the integration of 32-Kbyte RAM within the Am186 microcontrollers. The internal RAM for the Am186 microcontroller is a 16K x 16-bit wide array (32 Kbyte), which provides the same performance as a 16-bit external zero-wait-state RAM. The internal RAM's location within the addressable memory on the SD186ER demonstration board is user configurable.

**NOTE:** The E86MON software maps the internal RAM from 0h to 7FFFh. Available user-application RAM resides from 410h to 7540h. See the *E86MON™ User's Manual* included in your kit for more information.

For more information on configuring the internal RAM, see the Internal Memory Chip Select (IMCS) documentation in the *Am186™ER and Am188™ER Microcontrollers Data Sheet*.

---

## RS-232 Serial Port

The SD186ER demonstration board provides one on-board RS-232 serial port that is driven directly by the Am186ER microcontroller. The RS-232 serial port (P1) is equipped with a DB-9 connector. The pin assignment for the DB-9 connector is shown in Figure 2-3 below.

The RS-232 specification calls for signals that are driven at non-TTL levels. Single-chip RS-232 driver/receiver devices (MAX232) are used to convert to and from the required voltages.

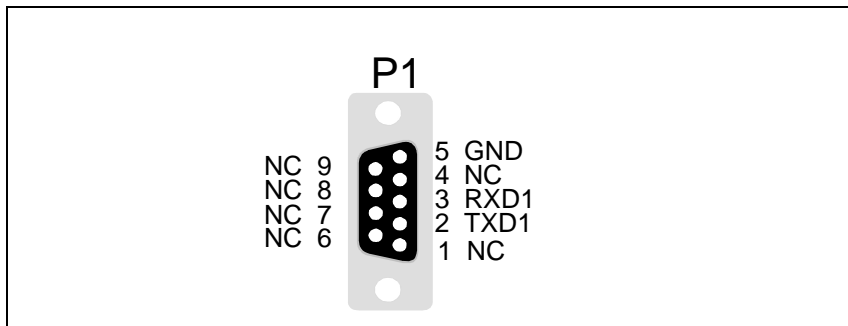

*Figure 2-3. DB-9 Serial Connector Pinout*

---

## Clock and Reset Logic

The Am186ER microcontroller can be configured for either a 4x, 1x, or ½x clock mode. As configured on the SD186ER demonstration board, the microcontroller is in a 4x clock mode. The input is generated by a 12.5-MHz fundamental mode crystal (Y1) that is connected to the X1/X2 inputs of the microcontroller, resulting in a 50-MHz system clock.

Solder pads are provided on the board to enable 1x and ½x clock modes. When installed, R4 connects  $\overline{\text{CLKSEL1}}$  to ground, and R7 connects  $\overline{\text{CLKSEL2}}$  to ground. These pads are normally unpopulated. You may install 100-kΩ resistors in either one of the two positions to enable 1x or ½x clock mode (see Table 2-2).

**NOTE:** Refer to the *Am186™ER and Am188™ER Microcontrollers Data Sheet* for detailed information on clock modes.

System reset is controlled by a voltage supply supervisor (TI TL7705ACD, U1). This device generates the processor's reset input, asserting the Am186ER microcontroller's RES pin for 13 ms when the RESET switch is depressed. The voltage supply supervisor also holds reset active when the power falls below 4.75 V.

**Table 2-2. SD186ER Clock Modes**

Clock Mode	R4 Population	R7 Population	System Clock
4x	Unpopulated	Unpopulated	50 MHz
1x	Unpopulated	Populated	12.5 MHz
½x	Populated	Unpopulated	6.25 MHz

---

## Am186 Expansion Interface

The SD186ER demonstration board supports the PC/104 form-factor expansion-type connector for additional prototyping and testing. The traditional PC/104 signals are not present on the board; however, the Am186 expansion interface enables you to attach wirewrap or prototype boards that have the same standard physical interface. The pinout of the expansion interface is shown in the figures that follow.

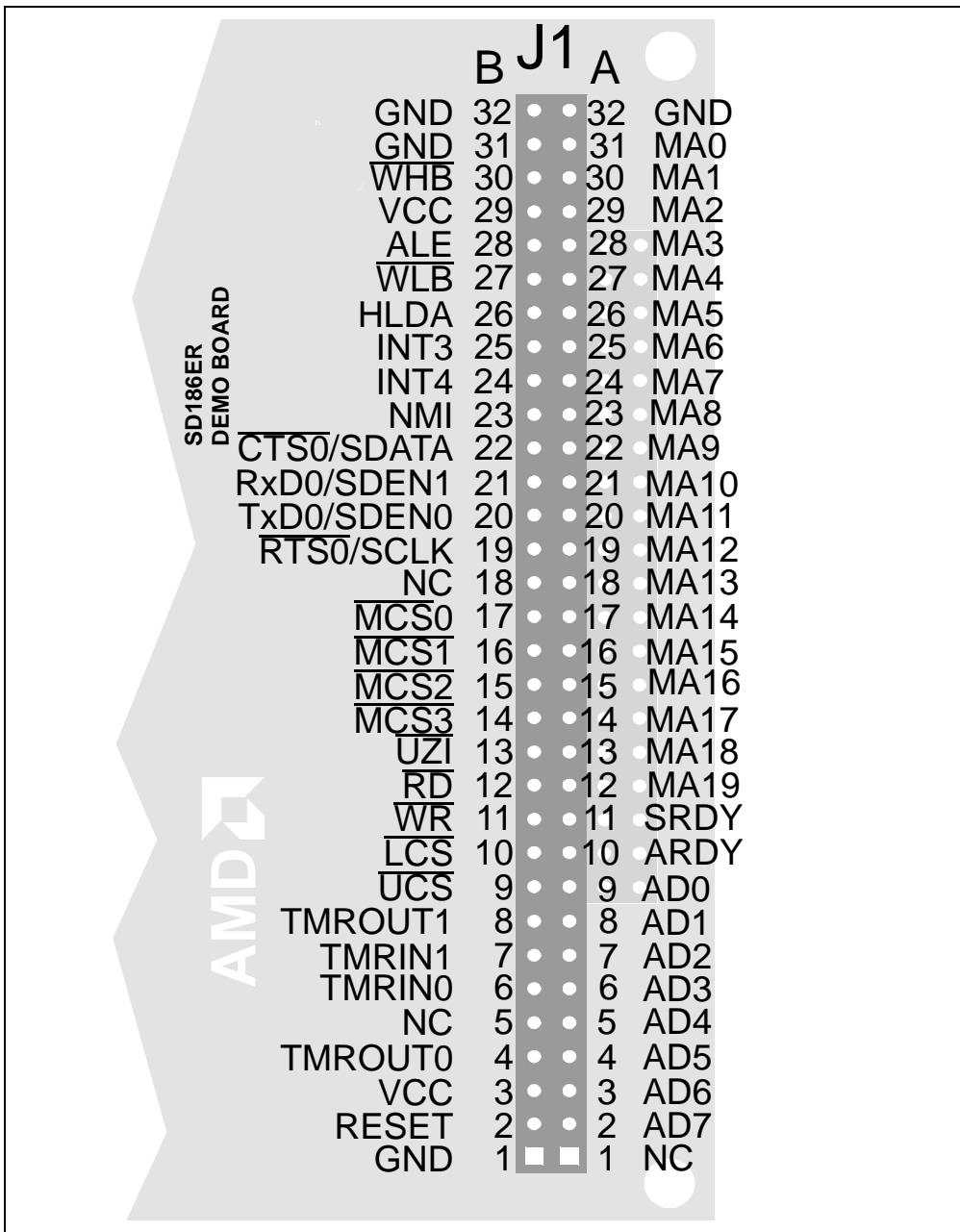

Figure 2-4. Am186 Expansion Interface Pinout (J1)

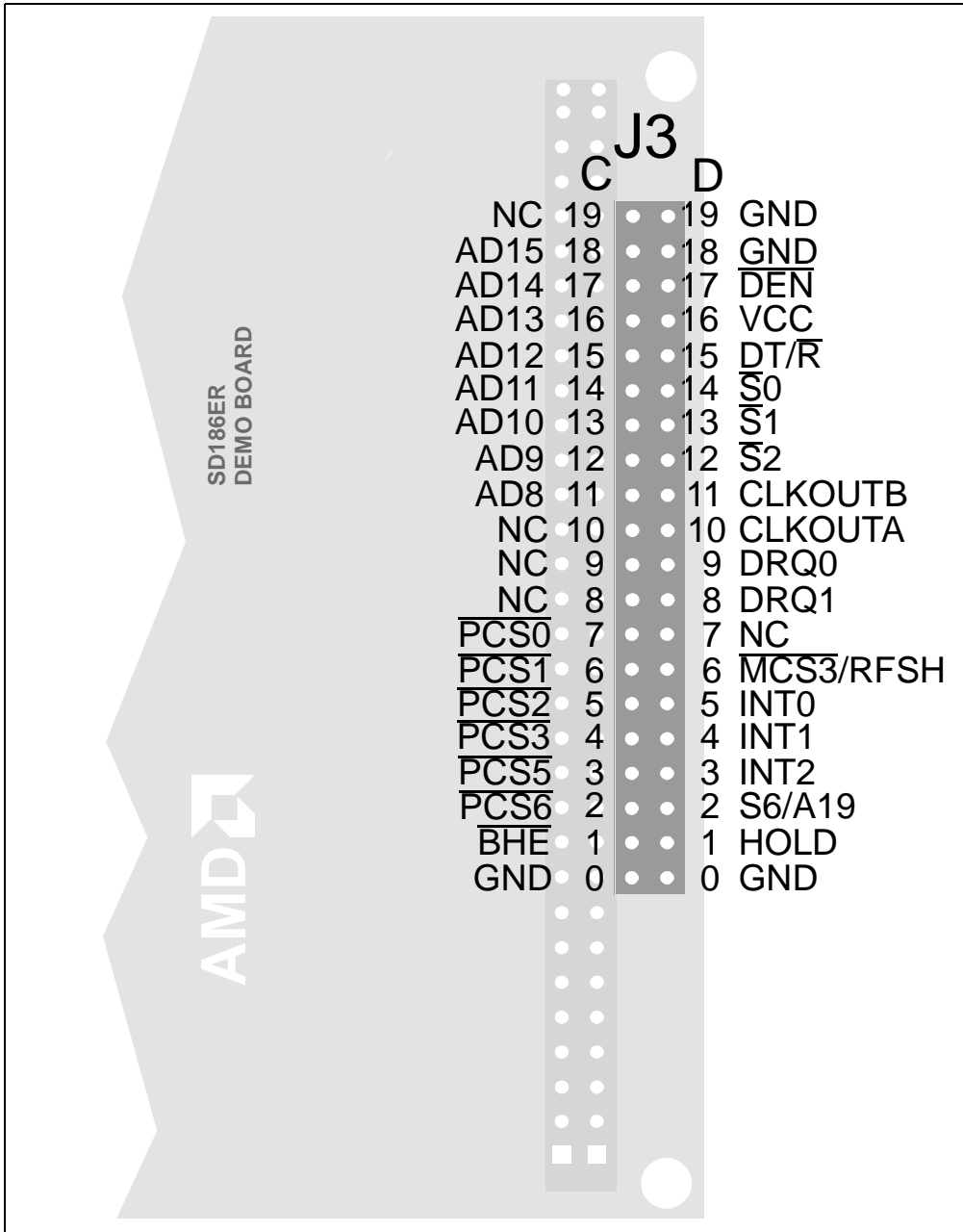

Figure 2-5. Am186 Expansion Interface Pinout (J3)

---

## PIO Activity LED Indicators

The SD186ER demonstration board uses on-board LED indicators to show activity on eight programmable I/O (PIO) signals from the Am186ER microcontroller. Table 2-3 shows which PIO signal is represented by each LED.

**Table 2-3. PIO LED Indicator Interface**

LED	PIO Pin Name	PIO Register Bit Number
CR2	MCST	15
CR3	MCS0	14
CR4	DEN	5
CR5	DT/ $\bar{R}$	4
CR6	$\bar{P}CS5$	3
CR7	$\bar{P}CS6$	2
CR8	TMROUT1	1
CR9	TMRIN1	0

# Power Supply

When used as a stand-alone board, the SD186ER demonstration board requires an input power supply of 5.0 V DC,  $\pm 5\%$ , 250 mA. The 3.3-V supply for the microcontroller is provided by the low drop-out voltage regulator U5.

When adding components to the SD186ER demonstration board via the Am186 expansion interface, additional power may be necessary.

The power supply connector is a 5.5-mm barrel connector where the center post is  $V_{CC}$  and the outer ring is GND, as shown in Figure 2-6.

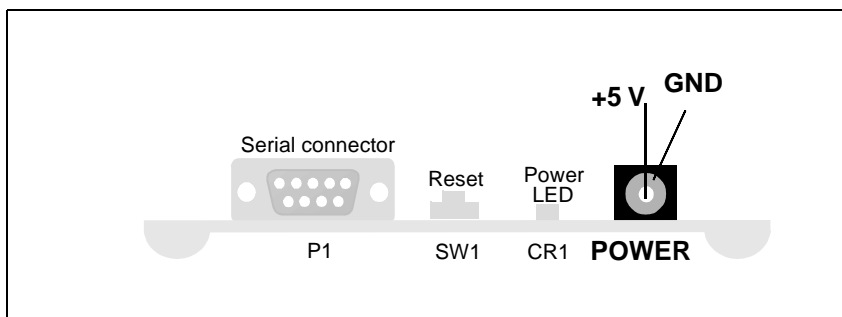

Figure 2-6. Power Supply Polarity



**CAUTION:** Use the 5-V universal power supply included with the kit. Using a 9-V supply will permanently damage the board.

# Chapter 3



---

## Product Support

This chapter provides information on:

- Reaching and using the AMD Corporate Applications technical support services, on page 3-2
- Product information available through AMD's World Wide Web and FTP sites, on page 3-4
- Support tools for the E86 family, on page 3-5

---

# AMD Corporate Applications Technical Support Services

Technical support for the E86 family of microcontrollers and corresponding support products is available via e-mail, online (BBS and WWW), and through telephone or fax.

---

## E-Mail Support

Please include your name, company, telephone and fax numbers, AMD product requiring support, and question or problem in all e-mail correspondence.

In the USA and Canada, send mail to:

HW.Support@amd.com

In Europe and the UK, send mail to:

euro.tech@amd.com

---

## Online Support

AMD offers technical support on our WWW site and through our bulletin board services. See “Product Support” on page 3-4 for more on what our WWW and FTP sites have to offer.

### WWW Technical Support

Go to AMD’s home page at <http://www.amd.com> and click on “Service” for the latest AMD technical support phone numbers, software, and Frequently Asked Questions.

### Bulletin Board Support

Country	Number
USA and Canada	(408) 749-4659
UK and Europe	44-(0) 1276-803-211

---

## Telephone and Fax Support

Telephone assistance is available in the U.S. from 8:00 A.M. to 5:00 P.M. Pacific time, Monday through Friday (except major holidays). In Europe, assistance is available during U.K. business hours. Contact the hotlines at one of the following telephone or fax numbers.

### Direct Dial Numbers

Country	Number
USA and Canada	Tel.: (408) 749-5703 Fax: (408) 749-4753
Japan	Tel.: (03) 3346-7550 Fax: (03) 3346-9828
Far East Asia	Fax: (852) 2956-0599
Germany	Tel.: 089 450 53199
UK and Europe	Tel.: 44-(0) 1276-803-299 Fax: 44-(0) 1276-803-298

### Toll-Free Numbers

Country	Number
USA and Canada	(800) 222-9323
France	0590-8621
Italy	1678-77224
Japan	0031-11-1163

---

# Product Support

AMD's WWW and FTP sites are described below. Questions, requests, and input concerning these sites can be sent via e-mail to [webmaster@amd.com](mailto:webmaster@amd.com).

---

## WWW Site

A subset of the AMD WWW pages, the embedded processor pages are frequently updated and include general product information, technical documentation, and support and tool information. To access these pages, go to the AMD home page at <http://www.amd.com> and click on "Embedded Processors" or access the pages directly at <http://www.amd-embedded.com>.

The "Embedded Processors" home page is divided into four sections:

- "What's New" announces new E86 family products, and highlights new applications using our products.
- "Product Overviews" briefly describes all the microprocessors and microcontrollers in the E86 family, and describes how these parts are ideal in specific focus markets.
- "Support and Tools" provides information about the tools that support our processors, and offers online benchmarking tools.
- "Technical Documentation" provides the *Available Literature List* of datasheets, application notes, user's manuals, and promotional literature, and describes how to order these documents. Many are also available online in PDF form. (To access the Literature Ordering Center via telephone, call one of the numbers listed on the back cover of your manual.)
- "Demo Board Updates" provides a list to the AMD FTP site where the latest E86MON software releases are available.

12

---

## FTP Site

In addition to the documentation on our WWW pages, AMD provides software through an anonymous FTP site. To download the software, ftp to **ftp.amd.com** and log on as “anonymous” using your e-mail address as a password. Or via your web browser, go to **ftp://ftp.amd.com**. Software relating to the E86 family can be found in the **/pub/epd/e86/** directory.

---

## Third-Party Development Support Products

The FusionE86<sup>SM</sup> Program of Partnerships for Application Solutions provides the customer with an array of products designed to meet critical time-to-market needs. Products and solutions available from the AMD FusionE86 partners include emulators, hardware and software debuggers, board-level products, and software development tools, among others. The *FusionE86<sup>SM</sup> Catalog*, order #19255, describes these solutions.

In addition, mature development tools and applications for the x86 platform are widely available in the general marketplace.

# Appendix A



---

## Layout Diagram, Schematics, and Board Bill of Materials

This appendix contains a board layout diagram, schematics, and the bill of materials (BOM) for the SD186ER demonstration board.

# Board Layout Diagram

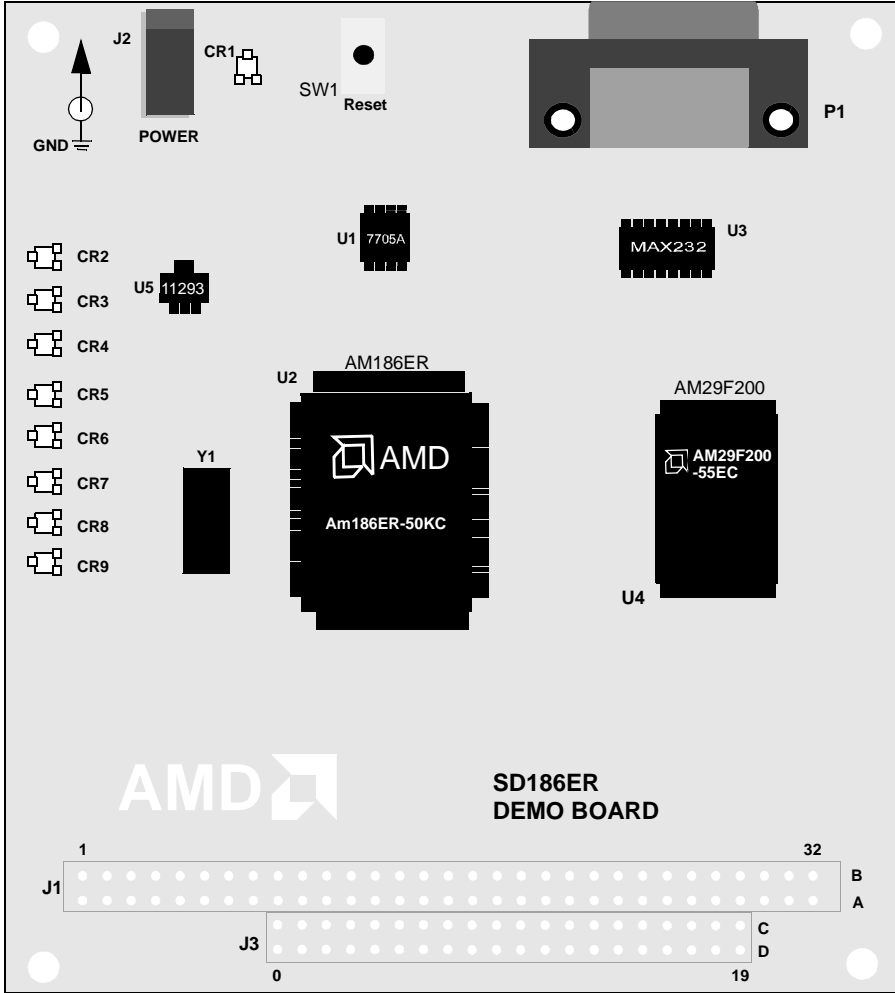

Figure A-1. SD186ER Demonstration Board Layout

---

# Schematics

The SD186ER demonstration board schematics have been blocked out to separate functionality of the design onto separate pages as follows:

- Page A-4 contains the Am186ER microcontroller and reset logic
- Page A-5 contains the serial ports, LEDs, and Flash devices
- Page A-6 contains the power connector and decoupling capacitors, expansion connector, and signal termination

**NOTE:** These schematics and design are subject to change.







# Board Bill of Materials (BOM)

**Table A-1. SD186ER Demonstration Board BOM**

Qty	Ref	Description	MFG1	Part No 1
1	C1	1.0 MFd, SMT, 16 V	Any	
7	C10, C12-C17	0.01 MFd, SMT, 16 V	Any	
1	C11	3.3 MFd, SMT, 16 V	Any	
2	C18, C19	22 PFd, SMT, 16 V	Any	
1	C2	0.1 MFd, SMT, 20 V	Any	
2	C3, C4	15 PFd, SMT, 16 V	Any	
4	C5-C8	0.1 MFd, SMT, 20 V	Any	
1	C9	22 MFd, SMT, C case, 20 V	Any	
9	CR1-CR9	LED, 3 Pin, SMT	ROHM	SLM-23VMW
0	J1	Expansion Connector, 64-Pin Header	Not populated	
1	J2	Power Jack, 5.5 mm, RA	Switchcraft	RAPC-712
0	J3	Expansion Connector, 40-Pin Header	Not populated	
1	P1	DB9 right angle connector, Front Metal-Shell	AMP	787844-1
13	R1, R21, R23, R24 R27-R35	100 kOhms, 5%	Any	
3	R11, R25, R26	33 Ohms, 5%	Any	
1	R13	390 Ohms, 5%	Any	
1	R2	10 kOhms, 5%	Any	
0	R4, R6, R7, R17, R22	Resistor place holders	Not populated	
3	R5, R8, R18	0 kOhms	Any	
8	R9, R10, R12, R14-R16, R19, R20	220 Ohms, 5%	Any	
1	SW1	Reset Switch, (SMT-J lead)	C&K	KT11P3JM
1	U1	Reset Controller, SMT	TI	TL7705ACD
1	U2	Am186ER Microcontroller	AMD	AM186ER-50KC/W
1	U3	RS-232 Driver, narrow SMT	Maxim	MAX232ACSE
1	U4	128K x 16 Flash EPROM (SMT)	AMD	Am29F200T-55EC
1	U5	3.3-V Low dropout voltage regulator	Linear Tech	LT1129CST-3.3
1	Y1	12.5-MHz High Frequency Quartz Crystal, 18 pF	KDS	



---

# Index

---

---

## A

---

Am186ER microcontroller  
  block diagram, 2-5  
  operating frequency, 2-4  
Am29F200 Flash, 2-6

---

## B

---

baud rate setting, 1-3  
BBS technical support, 3-2  
bill of materials for board, A-7

---

## C

---

$\overline{\text{CLKSEL}}$  pins, 2-8  
clock logic, 2-8  
clock rates supported, 2-8  
COM ports,  
  *See* ports  
connecting  
  demo board to PC, 1-2  
connectors  
  DB-9, 1-3  
conventions  
  documentation, xii  
CR1–CR9 LEDs  
  location on board, 2-2  
  on power-up, 1-4  
CR2–CR9 PIO LEDs, 2-11

---

## D

---

data bits setting, 1-3  
DB-9 serial connector pinout, 2-7  
DEN pin, 2-11  
documentation  
  conventions, xii  
  description of, x  
  reference material, xi  
DT/ $\overline{\text{R}}$  pin, 2-11

---

## E

---

E86MON utility  
  invoking, 1-4  
  no prompt, 1-5  
e-mail technical support, 3-2  
expansion interface, 2-8  
  J1 pinout, 2-9  
  J3 pinout, 2-10

---

## F

---

features  
  SD186ER demonstration board, ix  
Flash memory overview, 2-6  
FTP site, 3-5  
FusionE86 program, 3-5

---

## H

---

hotline numbers, 3-3

---

## I

---

installing

    requirements, 1-2

    troubleshooting, 1-5

interfaces

    expansion, 2-8

    RS-232 serial, 2-7

---

## J

---

J1, J2, and J3 locations on board, 2-2

---

## L

---

LEDs

    CR1–CR9, 1-4

    flashing incorrectly, 1-5

    no power, 1-5

    PIO indicators, 2-11

---

## M

---

MCS pins, 2-10

memory

    Flash memory overview, 2-6

    ROM, 2-6

---

## P

---

P1 location on board, 2-2

parity setting, 1-3

---

PC

    connecting demo board to, 1-2

PC/104 support, 2-8

PCS pins, 2-11

pinout

    DB-9 serial connector, 2-7

    expansion interface (J1), 2-9

    expansion interface (J3), 2-10

    RS-232 serial port, 2-7

PIO signals

    mapped to LEDs, 2-11

    overview, 2-11

ports

    COM, 1-3

    expansion, 2-8

    RS-232 serial, 2-7

    serial, 1-3

power supply

    5-V vs. 9-V, 2-12

    input requirements, 2-12

    polarity, 2-12

    to board, 1-3

product support

    FTP site, 3-5

    third party (FusionE86), 3-5

    WWW site, 3-4

---

## R

---

$\overline{\text{RES}}$  pin, 2-8

RESET button

    nothing happens when pushing, 1-5

    resetting board with, 1-4

reset logic, 2-8

ROM space, 2-6

RS-232 serial port. *See* ports

---

---

## S

---

schematics, A-3

SD186ER demonstration board

- bill of materials, A-7
- block diagram, ix
- clock logic, 2-8
- connecting to PC, 1-2
- documentation, x
- expansion interface, 2-8
- features, viii
- installing, 1-2
- layout and placement, 2-2
- layout illustration, 2-3, A-2
- LEDs, 2-11
- overview, vii
- parts list, 2-2
- PIOs, 2-11
- power supply, 2-12
- reset logic, 2-8
- ROM space, 2-6
- RS-232 serial port, 2-7
- schematics, A-3
- technical support, 3-1

serial ports

- See* ports

stop bits setting, 1-3

support, product. *See* product support

support, technical. *See* technical support

SW1 location on board, 2-2

---

## T

---

technical support, 3-1

- BBS support, 3-2
- e-mail support, 3-2
- hotline numbers, 3-3
- WWW support, 3-2

terminal emulation program

- displaying unreadable characters, 1-5
- locking up, 1-5

TMRIN1 pin, 2-11

TMROUT1 pin, 2-11

troubleshooting

- installation, 1-5

---

## U

---

U1–U5 locations on board, 2-2

UCS (Upper Memory Chip Select) signal, 2-6

---

## W

---

WWW

- product support, 3-4
- technical support, 3-2

---

## Y

---

Y1 location on board, 2-2