



Am186™ CH

High-Performance, 80C186-Compatible 16-Bit Embedded HDLC Microcontroller

DISTINCTIVE CHARACTERISTICS

■ E86™ family of x86 embedded processors offers improved time-to-market

- Software migration (backwards- and upwards-compatible)
- World-class development tools, applications, and system software

■ Serial Communications Peripherals

- Two High-level Data Link Control (HDLC) channels
- Two independent Time Slot Assigners (TSAs)
- Physical interface for HDLC channels can be raw DCE or PCM Highway
- High-Speed UART with autobaud
- UART
- Synchronous serial interface (SSI)
- SmartDMA™ channels (4) to support HDLC

■ System Peripherals

- Three programmable 16-bit timers
- Hardware watchdog timer
- General-purpose DMA (4 channels)

- Programmable I/O (48 PIO signals)
- Interrupt Controller (36 maskable interrupts)

■ Memory and Peripheral Interface

- Integrated DRAM controller
- Glueless interface to RAM/ROM/Flash memory (55-ns Flash memory required for zero-wait-state operation at 50 MHz)
- Fourteen chip selects (8 peripherals, 6 memory)
- External bus mastering support
- Multiplexed and nonmultiplexed address/data bus
- Programmable bus sizing
- 8-bit boot option

■ Available in the following package:

- 160-pin plastic quad flat pack (PQFP)
- 25-, 40-, and 50-MHz operating frequencies
- Low-voltage operation, $V_{CC} = 3.3 \text{ V} \pm 0.3 \text{ V}$
- Commercial and industrial temperature rating
- 5-V-tolerant I/O (3.3-V output levels)

GENERAL DESCRIPTION

The Am186™CH HDLC microcontroller is a member of AMD's Comm86™ family of communications-specific microcontrollers. The microcontroller is a derivative of the Am186CC communications controller and is pin-compatible with that device.

The Am186CH HDLC microcontroller is a cost-effective, high-performance microcontroller solution for communications applications. This highly integrated microcontroller enables customers to save system costs and increase performance over 8-bit microcontrollers and other 16-bit microcontrollers.

The microcontroller offers the advantages of the x86 development environment's widely available native development tools, applications, and system software. Additionally, the microcontroller uses the industry-standard 186 instruction set that is part of the AMD E86™ family, which continually offers instruction-set-compatible upgrades. Built into the Am186CH HDLC microcontroller is a wide range of communications features required in many communications

applications, including High-level Data Link Control (HDLC).

Comprehensive development support is available from AMD and its FusionE86™ partners. A customer development platform board is available. AMD and its FusionE86 partners also offer boards, schematics, drivers, protocol stacks, and routing software to enable fast time to market.

ORDERING INFORMATION

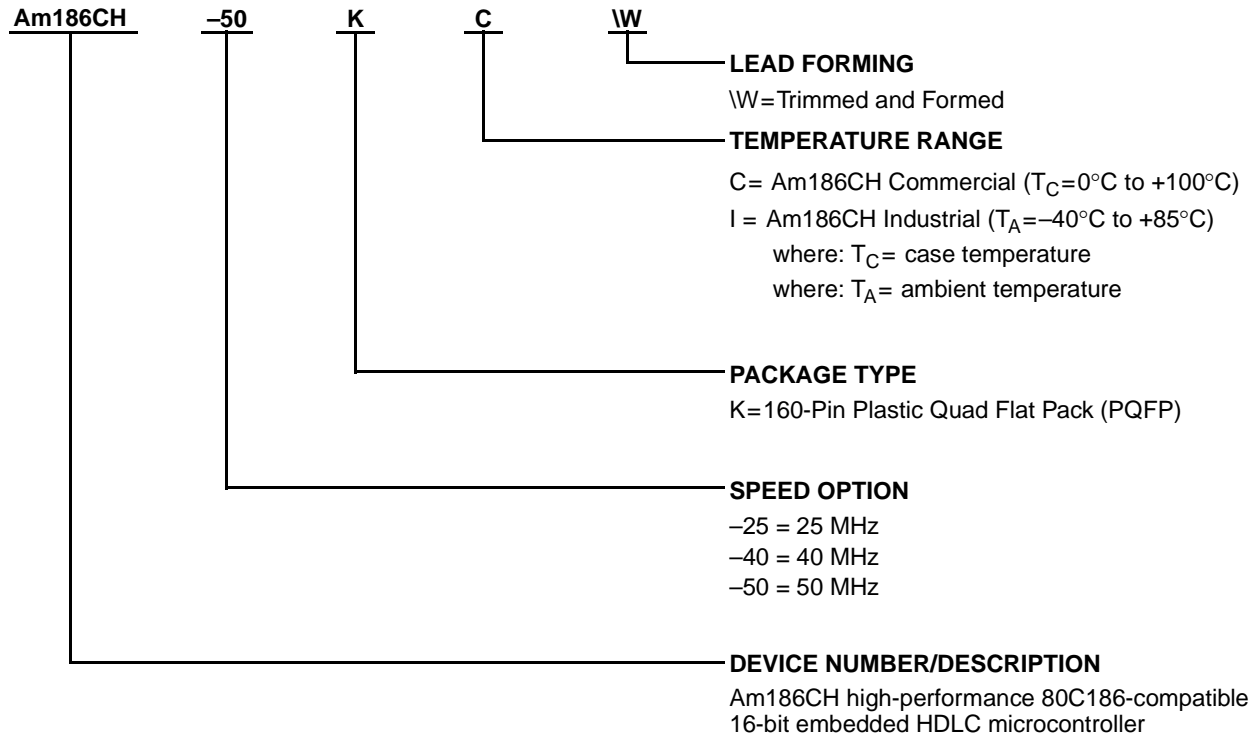

Valid Combinations	
Am186CH-25 Am186CH-40 Am186CH-50	KCW
Am186CH-25 Am186CH-40	KIW

Valid Combinations

Valid combinations list configurations planned to be supported in volume for this device. Consult the local AMD sales office to confirm availability of specific valid combinations and to check on newly released combinations.

TABLE OF CONTENTS

Distinctive Characteristics	1
General Description	1
Ordering Information	2
Table of Contents	3
List of Figures	4
List of Tables	5
Logic Diagram By Interface	6
Logic Diagram By Default Pin Function	7
Pin Connection Diagram—160-Pin PQFP Package	8
Pin and Signal Tables	9
Signal Descriptions	12
Architectural Overview	24
Detailed Description	24
Am186™ Embedded CPU	25
Memory Organization	25
I/O Space	25
Serial Communications Support	26
Two HDLC Channels and Two TSAs	26
Four SmartDMA™ Channels.....	26
Two Asynchronous Serial Ports	26
Synchronous Serial Port.....	27
System Peripherals	27
Interrupt Controller	27
Four General-Purpose DMA Channels	27
48 Programmable I/O Signals	27
Three Programmable Timers	27
Hardware Watchdog Timer	28
Memory and Peripheral Interface	28
System Interfaces.....	28
DRAM Support	30
Chip Selects	30
Clock Control	31
In-Circuit Emulator Support	31
Applications	31
Clock Generation and Control	33
Features	33
System Clock	33
Crystal-Driven Clock Source	34
External Clock Source	35
Static Operation	35
PLL Bypass Mode	35
UART Baud Clock	35
Power Supply Operation	36
Power Supply Connections	36
Input/Output Circuitry	36
PIO Supply Current Limit	36
Absolute Maximum Ratings	37
Operating Ranges	37
DC Characteristics over Commercial and Industrial Operating Ranges	37
Maximum Load Derating	38
Capacitance	38
Power Supply Current	38

Thermal Characteristics—PQFP Package	39
Commercial and Industrial Switching Characteristics and Waveforms	40
Switching Characteristics over Commercial and Industrial Operating Ranges	47
Appendix A—Pin Tables	A-1
CPU PLL Modes.....	A-7
Pin List Table Column Definitions	A-10
Appendix B—Physical Dimensions: PQR160, Plastic Quad Flat Pack (PQFP)	B-1
Appendix C—Customer Support	C-1
Related AMD Products—E86™ Family Devices	C-1
Related Documents	C-2
Am186CC/CH/CU Microcontroller Customer Development Platform	C-2
Third-Party Development Support Products	C-2
Customer Service	C-2
Hotline and World Wide Web Support.....	C-2
Corporate Applications Hotline.....	C-2
World Wide Web Home Page	C-3
Documentation and Literature	C-3
Literature Ordering	C-3
Index.....	Index-1

LIST OF FIGURES

Figure 1. Am186CH Microcontroller Block Diagram	24
Figure 2. Two-Component Address Example	25
Figure 3. Am186CH Microcontroller Address Bus — Default Operation	29
Figure 4. Am186CH Microcontroller—Address Bus Disable In Effect	29
Figure 5. 32-Channel Linecard System Application	32
Figure 6. System Clock Generation	33
Figure 7. Suggested System Clock Frequencies, Clock Modes, and Crystal Frequencies ..	34
Figure 8. External Interface to Support Clocks—Fundamental Mode Crystal	34
Figure 9. External Interface to Support Clocks—External Clock Source	35
Figure 10. UART and High-Speed UART Clocks	35
Figure 11. Typical I _{CC} Versus Frequency	38
Figure 12. Thermal Resistance(°C/Watt)	39
Figure 13. Thermal Characteristics Equations	39
Figure 14. Key to Switching Waveforms	40
Figure 15. Read Cycle Waveforms	49
Figure 16. Write Cycle Waveforms	52
Figure 17. Software Halt Cycle Waveforms	53
Figure 18. Peripheral Timing Waveforms	54
Figure 19. Reset Waveforms	55
Figure 20. Signals Related to Reset (System PLL in 1x or 2x Mode)	56
Figure 21. Signals Related to Reset (System PLL in 4x Mode)	56
Figure 22. Synchronous Ready Waveforms	57
Figure 23. Asynchronous Ready Waveforms	58
Figure 24. Entering Bus Hold Waveforms	59
Figure 25. Exiting Bus Hold Waveforms	60
Figure 26. System Clocks Waveforms—Active Mode (PLL 1x Mode)	62
Figure 27. PCM Highway Waveforms (Timing Slave)	63
Figure 28. PCM Highway Waveforms (Timing Master)	64
Figure 29. DCE Transmit Waveforms	65
Figure 30. DCE Receive Waveforms	65
Figure 31. SSI Waveforms	66
Figure 32. DRAM Read Cycle without Wait States Waveform	68

Figure 33.	DRAM Read Cycle with Wait States Waveform	68
Figure 34.	DRAM Write Cycle without Wait States Waveform	69
Figure 35.	DRAM Write Cycle with Wait States Waveform	69
Figure 36.	DRAM Refresh Cycle Waveform	70

LIST OF TABLES

Table 1.	PQFP Pin Assignments—Sorted by Pin Number	10
Table 2.	PQFP Pin Assignments—Sorted by Signal Name	11
Table 3.	Signal Descriptions Table Definitions.....	12
Table 4.	Signal Descriptions	13
Table 5.	Segment Register Selection Rules	26
Table 6.	Crystal Parameters	34
Table 7.	Typical Power Consumption Calculation.....	38
Table 8.	Thermal Characteristics (°C/Watt)	39
Table 9.	Alphabetical Key to Switching Parameter Symbols	41
Table 10.	Numerical Key to Switching Parameter Symbols	44
Table 11.	Read Cycle Timing	47
Table 12.	Write Cycle Timing	50
Table 13.	Software Halt Cycle Timing	53
Table 14.	Peripheral Timing	54
Table 15.	Reset Timing	55
Table 16.	External Ready Cycle Timing	57
Table 17.	Bus Hold Timing	59
Table 18.	System Clocks Timing	61
Table 19.	PCM Highway Timing (Timing Slave)	62
Table 20.	PCM Highway Timing (Timing Master)	64
Table 21.	DCE Interface Timing	65
Table 22.	SSI Timing	66
Table 23.	DRAM Timing	67
Table 24.	Power-On Reset (POR) Pin Defaults	A-2
Table 25.	Multiplexed Signal Trade-Offs	A-5
Table 26.	Reset Configuration Pins (Pinstraps)	A-7
Table 27.	PIOs Sorted by PIO Number	A-8
Table 28.	PIOs Sorted by Signal Name	A-9
Table 29.	Pin List Table Definitions.....	A-10
Table 30.	Pin List Summary	A-11

LOGIC DIAGRAM BY INTERFACE¹

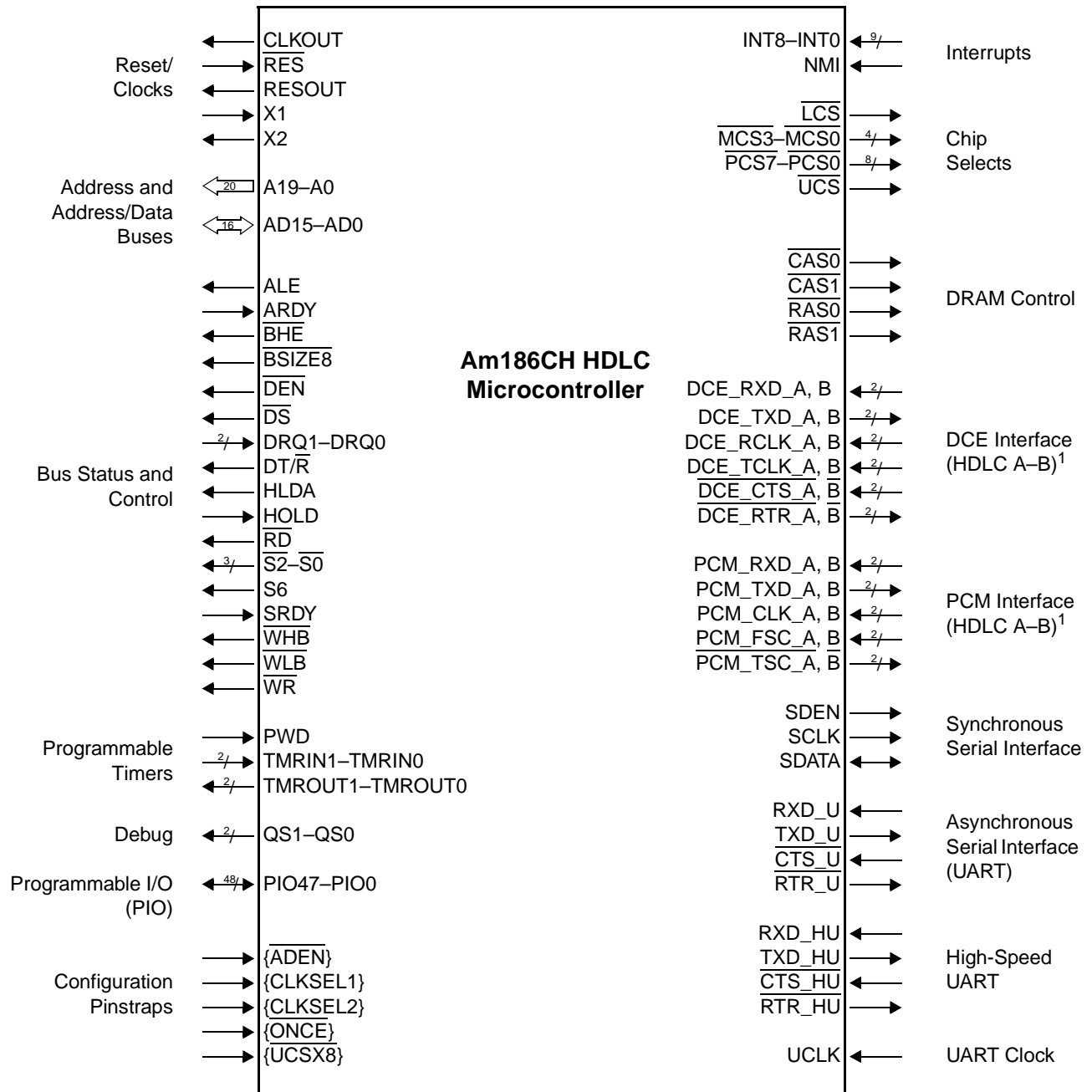

Notes:

1. Because of multiplexing, not all interfaces are available at once. Refer to Table 25, "Multiplexed Signal Trade-Offs," on page A-5.

LOGIC DIAGRAM BY DEFAULT PIN FUNCTION¹

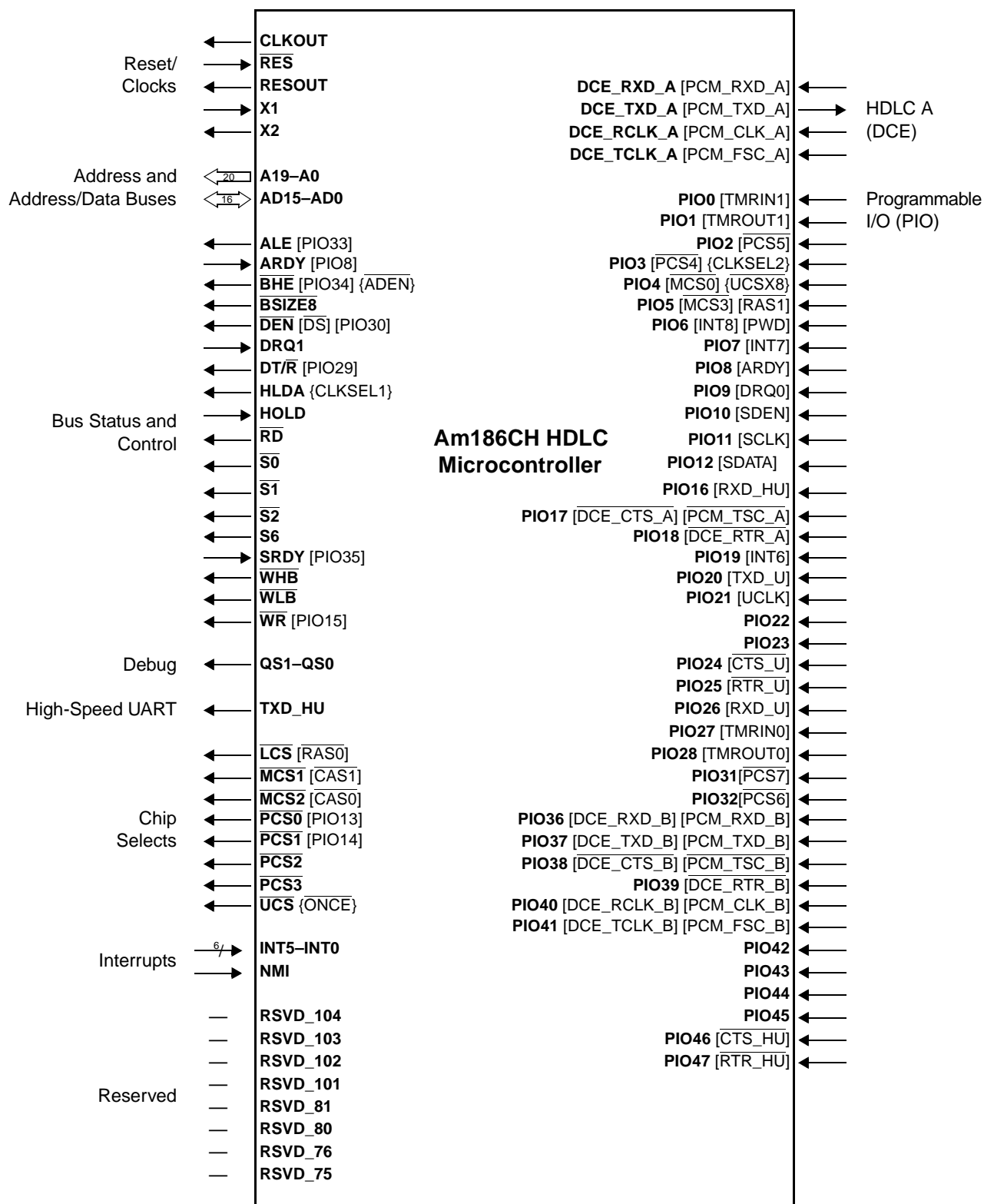

Notes:

1. Pin names in **bold** indicate the default pin function. Brackets, [], indicate alternate, multiplexed functions. Braces, { }, indicate pinstrap pins.

PIN CONNECTION DIAGRAM—160-PIN PQFP PACKAGE

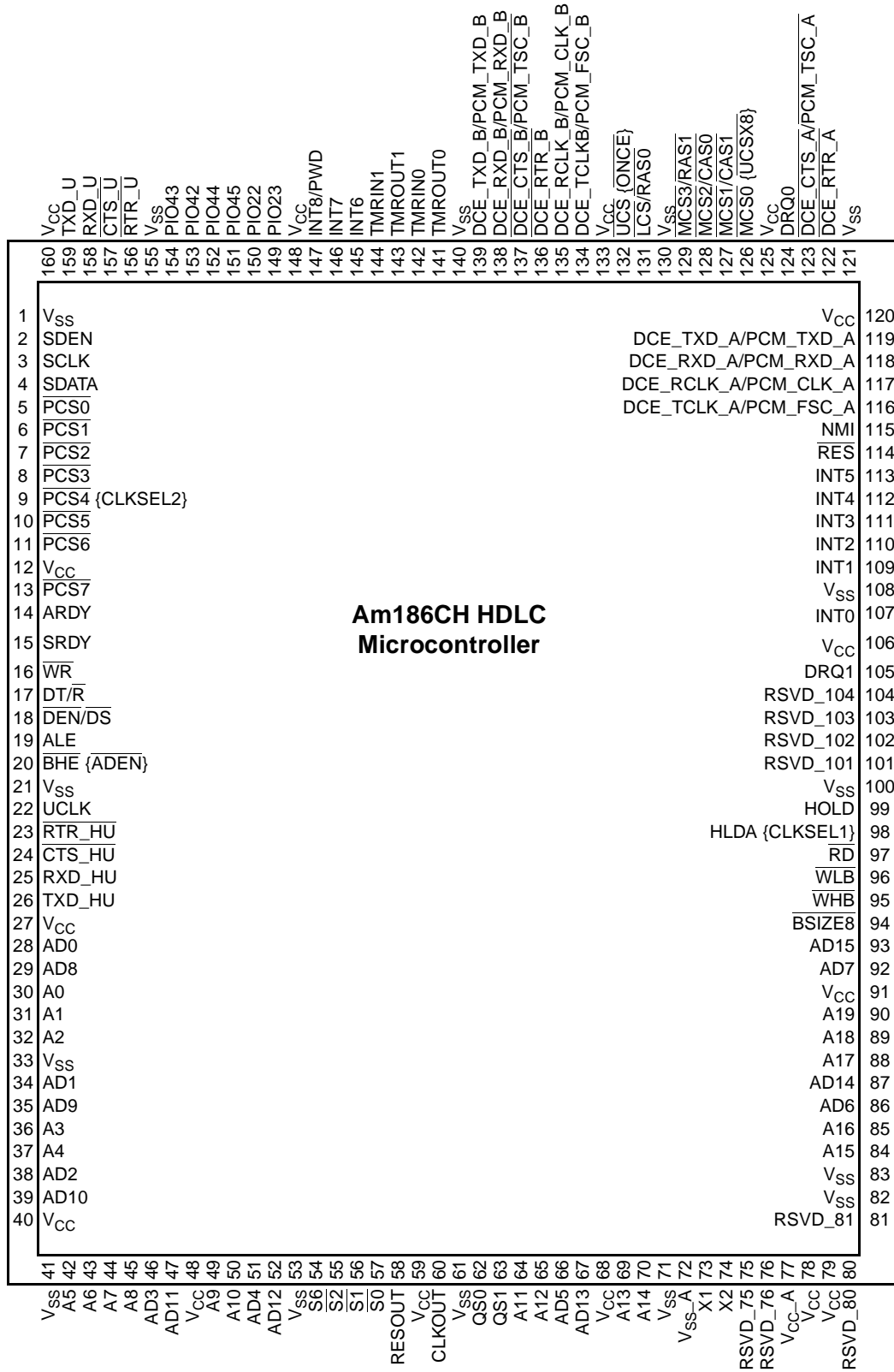

PIN AND SIGNAL TABLES

Table 1 on page 10 and Table 2 on page 11 show the pins sorted by pin number and signal name, respectively.

Table 4 on page 13 contains the signal descriptions (grouped alphabetically within function). The table includes columns listing the multiplexed functions and I/O type. Table 3 on page 12 defines terms used in Table 4.

Refer to Appendix A, “Pin Tables,” on page A-1 for an additional group of tables with the following information:

- Power-on reset (POR) pin defaults including pin numbers and multiplexed functions—Table 24 on page A-2.
- Multiplexed signal trade-offs—Table 25 on page A-5.

- Pinstrips and pinstrap options—Table 26 on page A-7.
- Programmable I/O pins ordered by PIO pin number and multiplexed signal name, respectively, including pin numbers, multiplexed functions, and pin configurations following system reset—Table 27 on page A-8 and Table 28 on page A-9.
- Pin and signal summary showing signal name and alternate function, pin number, I/O type, maximum load values, POR default function, reset state, POR default operation, hold state, and voltage—Table 30 on page A-11.

In all tables the brackets, [], indicate alternate, multiplexed functions, and braces, { }, indicate reset configuration pins (pinstraps). The line over a pin name indicates an active Low. The word pin refers to the physical wire; the word signal refers to the electrical signal that flows through it.

Table 1. PQFP Pin Assignments—Sorted by Pin Number¹

Pin No.	Name—Left Side	Pin No.	Name—Bottom Side	Pin No.	Name—Right Side	Pin No.	Name—Top Side
1	V _{SS}	41	V _{SS}	81	RSVD_81	121	V _{SS}
2	SDEN/PIO10	42	A5	82	V _{SS}	122	DCE_RTR_A/PIO18
3	SCLK/PIO11	43	A6	83	V _{SS}	123	DCE_CTS_A/ PCM_TSC_A/PIO17
4	SDATA/PIO12	44	A7	84	A15	124	DRQ0/PIO9
5	PCS0/PIO13	45	A8	85	A16	125	V _{CC}
6	PCS1/PIO14	46	AD3	86	AD6	126	MCS0/PIO4{UCSX8}
7	PCS2	47	AD11	87	AD14	127	MCS1/CAS1
8	PCS3	48	V _{CC}	88	A17	128	MCS2/CAS0
9	PCS4/PIO3{CLKSEL2}	49	A9	89	A18	129	MCS3/RAS1/PIO5
10	PCS5/PIO2	50	A10	90	A19	130	V _{SS}
11	PCS6/PIO32	51	AD4	91	V _{CC}	131	LCS/RAS0
12	V _{CC}	52	AD12	92	AD7	132	UCS{ONCE}
13	PCS7/PIO31	53	V _{SS}	93	AD15	133	V _{CC}
14	ARDY/PIO8	54	S6	94	BSIZE8	134	DCE_TCLK_B/ PCM_FSC_B/PIO41
15	SRDY/PIO35	55	S ₂	95	WHB	135	DCE_RCLK_B/ PCM_CLK_B/PIO40
16	WR/PIO15	56	S ₁	96	WLB	136	DCE_RTR_B/PIO39
17	DT/R/PIO29	57	S ₀	97	RD	137	DCE_CTS_B/ PCM_TSC_B/PIO38
18	DEN/DS/PIO30	58	RESOUT	98	HLDA{CLKSEL1}	138	DCE_RXD_B/ PCM_RXD_B/PIO36
19	ALE/PIO33	59	V _{CC}	99	HOLD	139	DCE_TXD_B/ PCM_TXD_B/PIO37
20	BHE/PIO34{ADEN}	60	CLKOUT	100	V _{SS}	140	V _{SS}
21	V _{SS}	61	V _{SS}	101	RSVD_101	141	TMROUT0/PIO28
22	UCLK/PIO21	62	QS0	102	RSVD_102	142	TMRIN0/PIO27
23	RTR_HU/PIO47	63	QS1	103	RSVD_103	143	TMROUT1/PIO1
24	CTS_HU/PIO46	64	A11	104	RSVD_104	144	TMRIN1/PIO0
25	RXD_HU/PIO16	65	A12	105	DRQ1	145	INT6/PIO19
26	TXD_HU	66	AD5	106	V _{CC}	146	INT7/PIO7
27	V _{CC}	67	AD13	107	INT0	147	INT8/PWD/PIO6
28	AD0	68	V _{CC}	108	V _{SS}	148	V _{CC}
29	AD8	69	A13	109	INT1	149	PIO23
30	A0	70	A14	110	INT2	150	PIO22
31	A1	71	V _{SS}	111	INT3	151	PIO45
32	A2	72	V _{SS} -A	112	INT4	152	PIO44
33	V _{SS}	73	X1	113	INT5	153	PIO42
34	AD1	74	X2	114	RES	154	PIO43
35	AD9	75	RSVD_75	115	NMI	155	V _{SS}
36	A3	76	RSVD_76	116	DCE_TCLK_A/ PCM_FSC_A	156	RTR_U/PIO25
37	A4	77	V _{CC} -A	117	DCE_RCLK_A/ PCM_CLK_A	157	CTS_U/PIO24
38	AD2	78	V _{CC}	118	DCE_RXD_A/ PCM_RXD_A	158	RXD_U/PIO26
39	AD10	79	V _{CC}	119	DCE_TXD_A/ PCM_TXD_A	159	TXD_U/PIO20
40	V _{CC}	80	RSVD_80	120	V _{CC}	160	V _{CC}

Notes:

1. See Table 27, "PIOs Sorted by PIO Number," on page A-8 for PIOs sorted by PIO number.

Table 2. PQFP Pin Assignments—Sorted by Signal Name¹

Signal Name	Pin No.	Signal Name	Pin No.	Signal Name	Pin No.	Signal Name	Pin No.
A0	30	CLKOUT	60	PCS4/PIO3{CLKSEL2}	9	TXD_U/PIO20	159
A1	31	CTS_HU/PIO46	24	PCS5/PIO2	10	UCLK/PIO21	22
A10	50	CTS_U/PIO24	157	PCS6/PIO32	11	UCS {ONCE}	132
A11	64	DCE_CTS_A/ PCM_TSC_A/PIO17	123	PCS7/PIO31	13	V _{CC}	12
A12	65	DCE_CTS_B/ PCM_TSC_B/PIO38	137	PIO22	150	V _{CC}	27
A13	69	DCE_RCLK_A/ PCM_CLK_A	117	PIO23	149	V _{CC}	40
A14	70	DCE_RCLK_B/ PCM_CLK_B/PIO40	135	PIO42	153	V _{CC}	48
A15	84	DCE_RTR_A/PIO18	122	PIO43	154	V _{CC}	59
A16	85	DCE_RTR_B/PIO39	136	PIO44	152	V _{CC}	68
A17	88	DCE_RXD_APCM_RXD_A	118	PIO45	151	V _{CC}	78
A18	89	DCE_RXD_B/ PCM_RXD_B/PIO36	138	QS0	62	V _{CC}	91
A19	90	DCE_TCLK_A/ PCM_FSC_A	116	QS1	63	V _{CC}	106
A2	32	DCE_TCLK_B/ PCM_FSC_B/PIO41	134	RD	97	V _{CC}	120
A3	36	DCE_TXD_APCM_TXD_A	119	RES	114	V _{CC}	125
A4	37	DCE_TXD_B/ PCM_TXD_B/PIO37	139	RESOUT	58	V _{CC}	133
A5	42	DEN/DS/PIO30	18	RSVD_75	75	V _{CC}	148
A6	43	DRQ0/PIO9	124	RSVD_76	76	V _{CC}	160
A7	44	DRQ1	105	RSVD_80	80	V _{CC}	79
A8	45	DT/R/PIO29	17	RSVD_81	81	V _{CC_A}	77
A9	49	HLDA{CLKSEL1}	98	RSVD_101	101	V _{SS}	1
AD0	28	HOLD	99	RSVD_102	102	V _{SS}	21
AD1	34	INT0	107	RSVD_103	103	V _{SS}	33
AD2	38	INT1	109	RSVD_104	104	V _{SS}	41
AD3	46	INT2	110	RTR_HU/PIO47	23	V _{SS}	53
AD4	51	INT3	111	RTR_U/PIO25	156	V _{SS}	61
AD5	66	INT4	112	RXD_HU/PIO16	25	V _{SS}	71
AD6	86	INT5	113	RXD_U/PIO26	158	V _{SS}	83
AD7	92	INT6/PIO19	145	S0	57	V _{SS}	100
AD8	29	INT7/PIO7	146	S1	56	V _{SS}	108
AD9	35	INT8/PWD/PIO6	147	S2	55	V _{SS}	121
AD10	39	LCS/RAS0	131	S6	54	V _{SS}	130
AD11	47	MCS0/PIO4{UCSX8}	126	SCLK/PIO11	3	V _{SS}	140
AD12	52	MCS1/CAS1	127	SDATA/PIO12	4	V _{SS}	155
AD13	67	MCS2/CAS0	128	SDEN/PIO10	2	V _{SS}	82
AD14	87	MCS3/RAS1/PIO5	129	SRDY/PIO35	15	V _{SS_A}	72
AD15	93	NMI	115	TMRIN0/PIO27	142	WHB	95
ALE/PIO33	19	PCS0/PIO13	5	TMRIN1/PIO0	144	WLB	96
ARDY/PIO8	14	PCS1/PIO14	6	TMROUT0/PIO28	141	WR/PIO15	16
BHE/PIO34{ADEN}	20	PCS2	7	TMROUT1/PIO1	143	X1	73
BSIZE8	94	PCS3	8	TXD_HU	26	X2	74

Notes:

1. See Table 27, “PIOs Sorted by PIO Number,” on page A-8 for PIOs sorted by signal name.

Signal Descriptions

Table 4 on page 13 contains a description of the Am186CH HDLC microcontroller signals. Table 3 describes the terms used in Table 4. The signals are organized alphabetically within the following functional groups:

- Bus interface/general-purpose DMA request (page 13)
- Clocks/reset/watchdog timer (page 17)
- Reserved (page 18)
- Power and ground (page 18)
- Debug support (page 18)
- Chip selects (page 19)
- DRAM (page 19)
- Interrupts (page 20)
- Programmable I/O (PIOs) (page 21)
- Programmable timers (page 21)
- Asynchronous serial ports (UART and High-Speed UART) (page 21)
- Synchronous serial interface (SSI) (page 22)
- HDLC synchronous communication interfaces: channels A and B for Data Communications Equipment (DCE) and Pulse-Code Modulation (PCM) interfaces (page 22)

For pinstraps refer to Table 26, “Reset Configuration Pins (Pinstraps),” on page A-7.

Table 3. Signal Descriptions Table Definitions

Term	Definition
General terms	
[]	Indicates the pin alternate function; a pin defaults to the signal named without the brackets.
{ }	Indicates the reset configuration pin (pinstrap).
pin	Refers to the physical wire.
reset	An <i>external or power-on reset</i> is caused by asserting RES. An <i>internal reset</i> is initiated by the watchdog timer. A <i>system reset</i> is one that resets the Am186CH HDLC microcontroller (the CPU plus the internal peripherals) as well as any external peripherals connected to RESOUT. An external reset always causes a system reset; an internal reset can optionally cause a system reset.
signal	Refers to the electrical signal that flows across a pin.
<u>SIGNAL</u>	A line over a signal name indicates that the signal is active Low; a signal name without a line is active High.
Signal types	
B	Bidirectional
H	High
LS	Programmable to hold last state of pin
O	Totem pole output
OD	Open drain output
OD-O	Open drain output or totem pole output
PD	Internal pulldown resistor
PU	Internal pullup resistor
STI	Schmitt trigger input
STI-OD	Schmitt trigger input or open drain output
TS	Three-state output

Table 4. Signal Descriptions

Signal Name	Multiplexed Signal(s)	Type	Description
BUS INTERFACE/GENERAL-PURPOSE DMA REQUEST			
A19–A0	—	O	<p>Address Bus supplies nonmultiplexed memory or I/O addresses to the system one half of a CLKOUT period earlier than the multiplexed address and data bus (AD15–AD0). During bus-hold or reset conditions, the address bus is three-stated with pulldowns.</p> <p>When the lower or upper chip-select regions are configured for DRAM mode, the A19–A0 bus provides the row and column addresses at the appropriate times. The upper and lower memory chip-select ranges can be individually configured for DRAM mode.</p>
AD15–AD0	—	B	<p>Address and Data Bus time-multiplexed pins supply memory or I/O addresses and data to the system. This bus can supply an address to the system during the first period of a bus cycle (t_1). It transmits (write cycle) or receives (read cycle) data to or from the system during the remaining periods of that cycle (t_2, t_3, and t_4). The address phase of these pins can be disabled—see the {ADEN} pin description in Table 26, “Reset Configuration Pins (Pinstraps),” on page A-7.</p> <p>During a reset condition, the address and data bus is three-stated with pulldowns, and during a bus hold it is three-stated.</p> <p>In addition, during a reset the state of the address and data bus pins (AD15–AD0) is latched into the Reset Configuration (RESCON) register. This feature can be used to provide software with information about the external system at reset time.</p>
ALE	[PIO33]	O	<p>Address Latch Enable indicates to the system that an address appears on the address and data bus (AD15–AD0). The address is guaranteed valid on the falling edge of ALE.</p> <p>ALE is three-stated and has a pulldown resistor during bus-hold or reset conditions.</p>
ARDY	[PIO8]	STI	<p>Asynchronous Ready is a true asynchronous ready that indicates to the microcontroller that the addressed memory space or I/O device will complete a data transfer. The ARDY pin is asynchronous to CLKOUT and is active High. To guarantee the number of wait states inserted, ARDY or SRDY must be synchronized to CLKOUT. If the falling edge of ARDY is not synchronized to CLKOUT as specified, an additional clock period can be added.</p> <p>To always assert the ready condition to the microcontroller, tie ARDY and SRDY High. If the system does not use ARDY, tie the pin Low to yield control to SRDY.</p>

Table 4. Signal Descriptions (Continued)

Signal Name	Multiplexed Signal(s)	Type	Description															
$\overline{\text{BHE}}$	[PIO34] {ADEN}	O	<p>Bus High Enable: During a memory access, $\overline{\text{BHE}}$ and the least-significant address bit (AD0) indicate to the system which bytes of the data bus (upper, lower, or both) participate in a bus cycle. The $\overline{\text{BHE}}$ and AD0 pins are encoded as follows:</p> <table border="1"> <thead> <tr> <th>$\overline{\text{BHE}}$</th> <th>AD0</th> <th>Type of Bus Cycle</th> </tr> </thead> <tbody> <tr> <td>0</td> <td>0</td> <td>Word transfer</td> </tr> <tr> <td>0</td> <td>1</td> <td>High byte transfer (bits 15–8)</td> </tr> <tr> <td>1</td> <td>0</td> <td>Low byte transfer (bits 7–0)</td> </tr> <tr> <td>1</td> <td>1</td> <td>Refresh</td> </tr> </tbody> </table> <p>$\overline{\text{BHE}}$ is asserted during t_1 and remains asserted through t_3 and t_W. $\overline{\text{BHE}}$ does not require latching. $\overline{\text{BHE}}$ is three-stated with a pullup during bus-hold and reset conditions.</p> <p>$\overline{\text{WLB}}$ and $\overline{\text{WHB}}$ implement the functionality of $\overline{\text{BHE}}$ and AD0 for high and low byte write enables, and they have timing appropriate for use with the nonmultiplexed bus interface.</p> <p>$\overline{\text{BHE}}$ also signals DRAM refresh cycles when using the multiplexed address and data (AD) bus. A refresh cycle is indicated when both $\overline{\text{BHE}}$ and AD0 are High. During refresh cycles, the AD bus is driven during the t_1 phase and three-stated during the t_2, t_3, and t_4 phases. The value driven on the A bus is undefined during a refresh cycle. For this reason, the A0 signal cannot be used in place of the AD0 signal to determine refresh cycles.</p>	$\overline{\text{BHE}}$	AD0	Type of Bus Cycle	0	0	Word transfer	0	1	High byte transfer (bits 15–8)	1	0	Low byte transfer (bits 7–0)	1	1	Refresh
$\overline{\text{BHE}}$	AD0	Type of Bus Cycle																
0	0	Word transfer																
0	1	High byte transfer (bits 15–8)																
1	0	Low byte transfer (bits 7–0)																
1	1	Refresh																
$\overline{\text{BSIZE8}}$	—	O	<p>Bus Size 8 is asserted during t_1–t_4 to indicate an 8-bit cycle, or is deasserted to indicate a 16-bit cycle.</p>															
$\overline{\text{DEN}}$	[$\overline{\text{DS}}$] [PIO30]	O	<p>Data Enable supplies an output enable to an external data-bus transceiver. $\overline{\text{DEN}}$ is asserted during memory and I/O cycles. $\overline{\text{DEN}}$ is deasserted when DT/$\overline{\text{R}}$ changes state. $\overline{\text{DEN}}$ is three-stated with a pullup during bus-hold or reset conditions.</p>															
[DRQ0] DRQ1	PIO9 —	STI STI	<p>DMA Requests 0 and 1 indicate to the microcontroller that an external device is ready for a DMA channel to perform a transfer. DRQ1–[DRQ0] are level-triggered and internally synchronized. DRQ1–[DRQ0] are not latched and must remain active until serviced.</p>															
[$\overline{\text{DS}}$]	$\overline{\text{DEN}}$ [PIO30]	O	<p>Data Strobe provides a signal where the write cycle timing is identical to the read cycle timing. When used with other control signals, [$\overline{\text{DS}}$] provides an interface for 68K-type peripherals without the need for additional system interface logic.</p> <p>When [$\overline{\text{DS}}$] is asserted, addresses are valid. When [$\overline{\text{DS}}$] is asserted on writes, data is valid. When [$\overline{\text{DS}}$] is asserted on reads, data can be driven on the AD bus.</p> <p>Following a reset, this pin is configured as $\overline{\text{DEN}}$. The pin is then configured by software to operate as [$\overline{\text{DS}}$].</p>															
DT/ $\overline{\text{R}}$	[PIO29]	O	<p>Data Transmit or Receive indicates which direction data should flow through an external data-bus transceiver. When DT/$\overline{\text{R}}$ is asserted High, the microcontroller transmits data. When this pin is deasserted Low, the microcontroller receives data. DT/$\overline{\text{R}}$ is three-stated with a pullup during a bus-hold or reset condition.</p>															

Table 4. Signal Descriptions (Continued)

Signal Name	Multiplexed Signal(s)	Type	Description
HLDA	{CLKSEL1}	O	<p>Bus-Hold Acknowledge is asserted to indicate to an external bus master that the microcontroller has relinquished control of the local bus. When an external bus master requests control of the local bus (by asserting HOLD), the microcontroller completes the bus cycle in progress, then relinquishes control of the bus to the external bus master by asserting HLDA and three-stating $\overline{S2-S0}$, $\overline{AD15-AD0}$, $\overline{S6}$, and $\overline{A19-A0}$. The following are also three-stated and have pullups: \overline{UCS}, \overline{LCS}, $\overline{MCS3-MCS0}$, $\overline{PCS7-PCS0}$, \overline{DEN}, \overline{RD}, \overline{WR}, \overline{BHE}, \overline{WHB}, \overline{WLB}, and $\overline{DT/R}$. ALE is three-stated and has a pulldown.</p> <p>When the external bus master has finished using the local bus, it indicates this to the microcontroller by deasserting HOLD. The microcontroller responds by deasserting HLDA.</p> <p>If the microcontroller requires access to the bus (for example, for refresh), the microcontroller deasserts HLDA before the external bus master deasserts HOLD. The external bus master must be able to deassert HOLD and allow the microcontroller access to the bus. See the timing diagrams for bus hold on page 59.</p>
HOLD	—	STI	<p>Bus-Hold Request indicates to the microcontroller that an external bus master needs control of the local bus.</p> <p>The microcontroller HOLD latency time—the time between HOLD request and HOLD acknowledge—is a function of the activity occurring in the processor when the HOLD request is received. A HOLD request is second only to DRAM refresh requests in priority of activity requests received by the processor. This implies that if a HOLD request is received just as a DMA transfer begins, the HOLD latency can be as great as four bus cycles. This occurs if a DMA word transfer operation is taking place from an odd address to an odd address. This is a total of 16 clock cycles or more if wait states are required. In addition, if locked transfers are performed, the HOLD latency time is increased by the length of the locked transfer. HOLD latency is also potentially increased by DRAM refreshes.</p> <p>The board designer is responsible for properly terminating the HOLD input.</p> <p>For more information, see the HLDA pin description above.</p>
\overline{RD}	—	O	<p>Read Strobe indicates to the system that the microcontroller is performing a memory or I/O read cycle. \overline{RD} is guaranteed not to be asserted before the address and data bus is three-stated during the address-to-data transition. \overline{RD} is three-stated with a pullup during bus-hold or reset conditions.</p>

Table 4. Signal Descriptions (Continued)

Signal Name	Multiplexed Signal(s)	Type	Description																																								
$\overline{S0}$ $\overline{S1}$ $\overline{S2}$	— — —	O	<p>Bus Cycle Status 2–0 indicate to the system the type of bus cycle in progress. $\overline{S2}$ can be used as a logical memory or I/O indicator, and $\overline{S1}$ can be used as a data transmit or receive indicator. $\overline{S2}$–$\overline{S0}$ are three-stated during bus hold and three-stated with a pullup during reset. The $\overline{S2}$–$\overline{S0}$ pins are encoded as follows:</p> <table border="1" style="margin-left: auto; margin-right: auto;"> <thead> <tr> <th colspan="4">Bus Status Pins</th> </tr> <tr> <th>$\overline{S2}$</th> <th>$\overline{S1}$</th> <th>$\overline{S0}$</th> <th>Bus Cycle</th> </tr> </thead> <tbody> <tr> <td>0</td> <td>0</td> <td>0</td> <td>Reserved</td> </tr> <tr> <td>0</td> <td>0</td> <td>1</td> <td>Read data from I/O</td> </tr> <tr> <td>0</td> <td>1</td> <td>0</td> <td>Write data to I/O</td> </tr> <tr> <td>0</td> <td>1</td> <td>1</td> <td>Halt</td> </tr> <tr> <td>1</td> <td>0</td> <td>0</td> <td>Instruction fetch</td> </tr> <tr> <td>1</td> <td>0</td> <td>1</td> <td>Read data from memory</td> </tr> <tr> <td>1</td> <td>1</td> <td>0</td> <td>Write data to memory</td> </tr> <tr> <td>1</td> <td>1</td> <td>1</td> <td>None (passive)</td> </tr> </tbody> </table>	Bus Status Pins				$\overline{S2}$	$\overline{S1}$	$\overline{S0}$	Bus Cycle	0	0	0	Reserved	0	0	1	Read data from I/O	0	1	0	Write data to I/O	0	1	1	Halt	1	0	0	Instruction fetch	1	0	1	Read data from memory	1	1	0	Write data to memory	1	1	1	None (passive)
Bus Status Pins																																											
$\overline{S2}$	$\overline{S1}$	$\overline{S0}$	Bus Cycle																																								
0	0	0	Reserved																																								
0	0	1	Read data from I/O																																								
0	1	0	Write data to I/O																																								
0	1	1	Halt																																								
1	0	0	Instruction fetch																																								
1	0	1	Read data from memory																																								
1	1	0	Write data to memory																																								
1	1	1	None (passive)																																								
S6	—	O	<p>Bus Cycle Status Bit 6: This signal is asserted during t_1–t_4 to indicate a DMA-initiated bus cycle or a refresh cycle. S6 is three-stated during bus hold and three-stated with a pulldown during reset.</p>																																								
SRDY	[PIO35]	STI	<p>Synchronous Ready indicates to the microcontroller that the addressed memory space or I/O device will complete a data transfer. The SRDY pin accepts an active High input synchronized to CLKOUT.</p> <p>Using SRDY instead of ARDY allows a relaxed system timing because of the elimination of the one-half clock period required to internally synchronize ARDY. To always assert the ready condition to the microcontroller, tie SRDY High. If the system does not use SRDY, tie the pin Low to yield control to ARDY.</p>																																								
\overline{WHB} \overline{WLB}	— —	O O	<p>Write High Byte and Write Low Byte indicate to the system which bytes of the data bus (upper, lower, or both) participate in a write cycle. In 80C186 microcontroller designs, this information is provided by \overline{BHE}, AD0, and \overline{WR}. However, by using \overline{WHB} and \overline{WLB}, the standard system interface logic and external address latch that were required are eliminated.</p> <p>\overline{WHB} is asserted with AD15–AD8. \overline{WHB} is the logical AND of \overline{BHE} and \overline{WR}. This pin is three-stated with a pullup during bus-hold or reset conditions.</p> <p>\overline{WLB} is asserted with AD7–AD0. \overline{WLB} is the logical AND of AD0 and \overline{WR}. This pin is three-stated with a pullup during bus-hold or reset conditions.</p>																																								
\overline{WR}	[PIO15]	O	<p>Write Strobe indicates to the system that the data on the bus is to be written to a memory or I/O device. \overline{WR} is three-stated with a pullup during bus-hold or reset conditions.</p>																																								

Table 4. Signal Descriptions (Continued)

Signal Name	Multiplexed Signal(s)	Type	Description
CLOCKS/RESET/WATCHDOG TIMER			
CLKOUT	—	O	<p>Clock Output supplies the clock to the system. Depending on the values of the CPU mode select pinstraps, {CLKSEL1} and {CLKSEL2}, CLKOUT operates at either the PLL frequency or the source input frequency during PLL Bypass mode. (See Table 26, “Reset Configuration Pins (Pinstraps),” on page A-7.) CLKOUT remains active during bus-hold or reset conditions.</p> <p>The DISCLK bit in the SYSCON register can be set to disable the CLKOUT signal. Refer to the <i>Am186™CC/CH/CU Microcontrollers Register Set Manual</i>, order #21916.</p> <p>All synchronous AC timing specifications not associated with SSI, HDLCs, and UARTs are synchronous to CLKOUT.</p>
$\overline{\text{RES}}$	—	STI	<p>Reset requires the microcontroller to perform a reset. When $\overline{\text{RES}}$ is asserted, the microcontroller immediately terminates its present activity, clears its internal logic, and on the deassertion of $\overline{\text{RES}}$, transfers CPU control to the reset address FFFF0h.</p> <p>$\overline{\text{RES}}$ must be asserted for at least 1 ms to allow the internal circuits to stabilize.</p> <p>$\overline{\text{RES}}$ can be asserted asynchronously to CLKOUT because $\overline{\text{RES}}$ is synchronized internally. For proper initialization, V_{CC} must be within specifications, and $\overline{\text{CLKOUT}}$ must be stable for more than four CLKOUT periods during which $\overline{\text{RES}}$ is asserted.</p> <p>If $\overline{\text{RES}}$ is asserted while the watchdog timer is performing a watchdog-timer reset, the external reset takes precedence over the watchdog-timer reset. This means that the RESOUT signal asserts as with any external reset and the WDTCN register will not have the RSTFLAG bit set. In addition, the microcontroller will exit reset based on the external reset timing (i.e., 4.5 clocks after the deassertion of $\overline{\text{RES}}$ rather than 2^{16} clocks after the watchdog timer timeout occurred).</p> <p>The microcontroller begins fetching instructions approximately 6.5 CLKOUT periods after $\overline{\text{RES}}$ is deasserted. This input is provided with a Schmitt trigger to facilitate power-on $\overline{\text{RES}}$ generation via a resistor-capacitor (RC) network.</p>
RESOUT	—	O	<p>Reset Out indicates that the microcontroller is being reset (either externally or internally), and the signal can be used as a system reset to reset any external peripherals connected to RESOUT.</p> <p>During an external reset, RESOUT remains active (High) for two clocks after $\overline{\text{RES}}$ is deasserted. The microcontroller exits reset and begins the first valid bus cycle approximately 4.5 clocks after $\overline{\text{RES}}$ is deasserted.</p>
[UCLK]	PIO21	STI	<p>UART Clock can be used instead of the processor clock as the source clock for either the UART or the High-Speed UART. The source clock for the UART and the High-Speed UART are selected independently and both can use the same source.</p>
X1	—	STI	<p>CPU Crystal Input (X1) and CPU Crystal Output (X2) provide connections for a fundamental mode, parallel-resonant crystal used by the internal oscillator circuit. If an external oscillator is used, inject the signal directly into X1 and leave X2 floating.</p>
X2	—	O	

Table 4. Signal Descriptions (Continued)

Signal Name	Multiplexed Signal(s)	Type	Description															
PINSTRAPS (See Table 26, "Reset Configuration Pins (Pinstraps)," on page A-7.)																		
RESERVED																		
RSVD_101	—		The pins RSVD_104–RSVD_101, RSVD_75, RSVD_76, RSVD_80, and RSVD_81 are reserved. The RSVD_75 pin should be tied externally to V _{SS} . All other seven reserved pins should not be connected.															
RSVD_102	—																	
RSVD_103	—																	
RSVD_104	—																	
RSVD_75	—																	
RSVD_76	—																	
RSVD_80	—																	
RSVD_81	—																	
POWER AND GROUND																		
V _{CC} (16)	—	STI	Digital Power Supply pins supply power (+3.3 ± 0.3 V) to the Am186CH HDLC microcontroller logic.															
V _{CC_A} (1)	—	STI	Analog Power Supply pin supplies power (+3.3 ± 0.3 V) to the oscillators and PLLs.															
V _{SS} (16)	—	STI	Digital Ground pins connect the Am186CH HDLC microcontroller logic to the system ground.															
V _{SS_A} (1)	—	STI	Analog Ground pin connects the oscillators and PLLs to the system ground.															
DEBUG SUPPORT																		
QS0	—	O	Queue Status 1–0 values provide information to the system concerning the interaction of the CPU and the instruction queue. The pins have the following meanings: <table border="1" style="margin-left: auto; margin-right: auto;"> <thead> <tr> <th>QS1</th> <th>QS0</th> <th>Queue Operation</th> </tr> </thead> <tbody> <tr> <td>0</td> <td>0</td> <td>None</td> </tr> <tr> <td>0</td> <td>1</td> <td>First opcode byte fetched from queue</td> </tr> <tr> <td>1</td> <td>0</td> <td>Queue was initialized</td> </tr> <tr> <td>1</td> <td>1</td> <td>Subsequent byte fetched from queue</td> </tr> </tbody> </table>	QS1	QS0	Queue Operation	0	0	None	0	1	First opcode byte fetched from queue	1	0	Queue was initialized	1	1	Subsequent byte fetched from queue
QS1	QS0	Queue Operation																
0	0	None																
0	1	First opcode byte fetched from queue																
1	0	Queue was initialized																
1	1	Subsequent byte fetched from queue																
QS1	—	O																
The following signals are also used by emulators: A19–A0, AD15–AD0, { $\overline{\text{ADEN}}$ }, ALE, ARDY, $\overline{\text{BHE}}$, $\overline{\text{BSIZE8}}$, $\overline{\text{CAS1}}$ – $\overline{\text{CAS0}}$, CLKOUT, {CLKSEL2–CLKSEL1}, HLDA, HOLD, $\overline{\text{LCS}}$, MCS3–MCS0, NMI, { $\overline{\text{ONCE}}$ }, QS1–QS0, RAS1–RAS0, RD, RES, RESOUT, S2–S0, S6, SRDY, UCS, {UCSX8}, WHB, WLB, WR. See the <i>Am186CC/CH/CU Microcontrollers User's Manual</i> , order #21914, for more information.																		

Table 4. Signal Descriptions (Continued)

Signal Name	Multiplexed Signal(s)	Type	Description
CHIP SELECTS			
$\overline{\text{LCS}}$	$[\overline{\text{RAS0}}]$	O	Lower Memory Chip Select indicates to the system that a memory access is in progress to the lower memory block. The base address and size of the lower memory block are programmable up to 512 Kbyte. $\overline{\text{LCS}}$ can be configured for 8-bit or 16-bit bus size. $\overline{\text{LCS}}$ is three-stated with a pullup resistor during bus-hold or reset conditions.
$[\overline{\text{MCS0}}]$ $\overline{\text{MCS1}}$ $\overline{\text{MCS2}}$ $[\overline{\text{MCS3}}]$	$\{\overline{\text{UCSX8}}\}$ PIO4 $[\overline{\text{CAS1}}]$ $[\overline{\text{CAS0}}]$ $[\overline{\text{RAS1}}]$ PIO5	O	Midrange Memory Chip Selects 3–0 indicate to the system that a memory access is in progress to the corresponding region of the midrange memory block. The base address and size of the midrange memory block are programmable. The midrange chip selects can be configured for 8-bit or 16-bit bus size. The midrange chip selects are three-stated with pullup resistors during bus-hold or reset conditions. $[\overline{\text{MCS0}}]$ can be programmed as the chip select for the entire middle chip select address range. Unlike the $\overline{\text{UCS}}$ and $\overline{\text{LCS}}$ chip selects that operate relative to the earlier timing of the nonmultiplexed A address bus, the $\overline{\text{MCS}}$ outputs assert with the multiplexed AD address and data bus timing.
$\overline{\text{PCS0}}$ $\overline{\text{PCS1}}$ $\overline{\text{PCS2}}$ $\overline{\text{PCS3}}$ $[\overline{\text{PCS4}}]$ $[\overline{\text{PCS5}}]$ $[\overline{\text{PCS6}}]$ $[\overline{\text{PCS7}}]$	$[\text{PIO13}]$ $[\text{PIO14}]$ — — PIO3 {CLKSEL2} PIO2 PIO32 PIO31	O	Peripheral Chip Selects 7–0 indicate to the system that an access is in progress to the corresponding region of the peripheral address block (either I/O or memory address space). The base address of the peripheral address block is programmable. $\overline{\text{PCS7}}$ – $\overline{\text{PCS0}}$ are three-stated with pullup resistors during bus-hold or reset conditions. Unlike the $\overline{\text{UCS}}$ and $\overline{\text{LCS}}$ chip selects that operate relative to the earlier timing of the nonmultiplexed A address bus, the $\overline{\text{PCS}}$ outputs assert with the multiplexed AD address and data bus timing.
$\overline{\text{UCS}}$	$\{\overline{\text{ONCE}}\}$	O	Upper Memory Chip Select indicates to the system that a memory access is in progress to the upper memory block. The base address and size of the upper memory block are programmable up to 512 Kbytes. $\overline{\text{UCS}}$ is three-stated with a weak pullup during bus-hold or reset conditions. The $\overline{\text{UCS}}$ can be configured for an 8-bit or 16-bit bus size out of reset. For additional information, see the $\{\overline{\text{UCSX8}}\}$ pin description in Table 26, “Reset Configuration Pins (Pinstraps),” on page A-7. After reset, $\overline{\text{UCS}}$ is active for the 64-Kbyte memory range from F0000h to FFFF0h, including the reset address of FFFF0h.
DRAM			
$[\overline{\text{CAS0}}]$ $[\overline{\text{CAS1}}]$	$\overline{\text{MCS2}}$ $\overline{\text{MCS1}}$	O	Column Address Strobes 1–0: When either the upper or lower chip select regions are configured for DRAM, these pins provide the column address strobe signals to the DRAM. The $\overline{\text{CAS}}$ signals can be used to perform byte writes in a manner similar to $\overline{\text{WLB}}$ and $\overline{\text{WHB}}$, respectively (i.e., $[\overline{\text{CAS0}}]$ corresponds to the low byte ($\overline{\text{WLB}}$) and $[\overline{\text{CAS1}}]$ corresponds to the high byte ($\overline{\text{WHB}}$)).
$[\overline{\text{RAS0}}]$	$\overline{\text{LCS}}$	O	Row Address Strobe 0: When the lower chip select region is configured to DRAM, this pin provides the row address strobe signal to the lower DRAM bank.
$[\overline{\text{RAS1}}]$	$[\overline{\text{MCS3}}]$ PIO5	O	Row Address Strobe 1: When the upper chip select region is configured to DRAM, this pin provides the row address strobe signal to the upper DRAM bank.

Table 4. Signal Descriptions (Continued)

Signal Name	Multiplexed Signal(s)	Type	Description
INTERRUPTS			
NMI	—	STI	<p>Nonmaskable Interrupt indicates to the microcontroller that an interrupt request has occurred. The NMI signal is the highest priority hardware interrupt and cannot be masked. The microcontroller always transfers program execution to the location specified by the nonmaskable interrupt vector in the microcontroller's interrupt vector table when NMI is asserted.</p> <p>Although NMI is the highest priority hardware interrupt source, it does not participate in the priority resolution process of the maskable interrupts. There is no bit associated with NMI in the interrupt in-service or interrupt request registers. This means that a new NMI request can interrupt an executing NMI interrupt service routine. As with all hardware interrupts, the interrupt flag (IF) is cleared when the processor takes the interrupt, disabling the maskable interrupt sources. However, if maskable interrupts are re-enabled by software in the NMI interrupt service routine (for example, via the STI instruction), the fact that an NMI is currently in service does not have any effect on the priority resolution of maskable interrupt requests. For this reason, it is strongly advised that the interrupt service routine for NMI should not enable the maskable interrupts.</p> <p>An NMI transition from Low to High is latched and synchronized internally, and it initiates the interrupt at the next instruction boundary. To guarantee that the interrupt is recognized, the NMI pin must be asserted for at least one CLKOUT period.</p> <p>The board designer is responsible for properly terminating the NMI input.</p>
INT5–INT0	—	STI	<p>Maskable Interrupt Requests 8–0 indicate to the microcontroller that an external interrupt request has occurred. If the individual pin is not masked, the microcontroller transfers program execution to the location specified by the associated interrupt vector in the microcontroller's interrupt vector table.</p> <p>Interrupt requests are synchronized internally and can be edge-triggered or level-triggered. The interrupt polarity is programmable. To guarantee interrupt recognition for edge-triggered interrupts, the user should hold the interrupt source for a minimum of five system clocks. A second interrupt from the same source is not recognized until after an acknowledge of the first.</p> <p>The board designer is responsible for properly terminating the INT8–INT0 inputs.</p>
[INT6]	PIO19	STI	
[INT7]	PIO7	STI	
[INT8]	[PWD] PIO6	STI	
<p>Also configurable as interrupts are PIO5, PIO15, PIO27, PIO29, PIO30, PIO33, PIO34, and PIO35. (See the <i>Am186CC/CH/CU Microcontrollers User's Manual</i>, order #21914 for more information.)</p>			

Table 4. Signal Descriptions (Continued)

Signal Name	Multiplexed Signal(s)	Type	Description
PROGRAMMABLE I/O (PIOS)			
PIO47–PIO0	(For multiplexed signals see Table 27, “PIOs Sorted by PIO Number,” on page A-8 and Table 28, “PIOs Sorted by Signal Name,” on page A-9.)	B	<p>Shared Programmable I/O pins can be programmed with the following attributes: PIO function (enabled/disabled), direction (input/output), and weak pullup or pulldown.</p> <p>After a reset, the PIO pins default to various configurations. The column entitled “Pin Configuration Following System Reset” in Table 27 on page A-8 and Table 28 on page A-9 lists the defaults for the PIOs. Most of the PIO pins are configured as PIO inputs with pullup after reset. See Table 30 on page A-11 for detailed termination information for all pins. The system initialization code must reconfigure any PIO pins as required.</p> <p>PIO5, PIO15, PIO27, PIO29, PIO30, and PIO33–PIO35 are capable of generating an interrupt on the shared interrupt channel 14.</p> <p>The multiplexed signals $\overline{\text{PIO33/ALE}}$, $\overline{\text{PIO8/ARDY}}$, $\overline{\text{PIO34/BHE}}$, $\overline{\text{PIO30/DEN}}$, $\overline{\text{PIO29/DT/R}}$, $\overline{\text{PIO14/PCS1–PIO13/PCS0}}$, $\overline{\text{PIO35/SRDY}}$, and $\overline{\text{PIO15/WR}}$ default to non-PIO operation at reset.</p> <p>The following PIO signals are multiplexed with alternate signals that can be used by emulators: PIO8, PIO15, PIO33, PIO34, and PIO35. Consider any emulator requirements for the alternate signals before using these pins as PIOs.</p>
PROGRAMMABLE TIMERS			
[PWD]	[INT8] PIO6	STI	<p>Pulse-Width Demodulator: If pulse-width demodulation is enabled, [PWD] processes a signal through the Schmitt trigger input. [PWD] is used internally to drive [TMRIN0] and [INT8], and [PWD] is inverted internally to drive [TMRIN1] and an additional internal interrupt. If interrupts are enabled and Timer 0 and Timer 1 are properly configured, the pulse width of the alternating [PWD] signal can be calculated by comparing the values in Timer 0 and Timer 1.</p> <p>In PWD mode, the signals [TMRIN0]/PIO27 and [TMRIN1]/PIO0 can be used as PIOs. If they are not used as PIOs they are ignored internally.</p> <p>The additional internal interrupt used in PWD mode uses the same interrupt channel as [INT7]. If [INT7] is used, it must be assigned to the shared interrupt channel.</p>
[TMRIN0] [TMRIN1]	PIO27 PIO0	STI STI	<p>Timer Inputs 1–0 supply a clock or control signal to the internal microcontroller timers. After internally synchronizing a Low-to-High transition on [TMRIN1]–[TMRIN0], the microcontroller increments the timer. [TMRIN1]–[TMRIN0] must be tied High if not being used. When PIO is enabled for one or both, the pin is pulled High internally.</p> <p>[TMRIN1]–[TMRIN0] are driven internally by [INT8]/[PWD] when pulse-width demodulation functionality is enabled. The [TMRIN1]–[TMRIN0] pins can be used as PIOs when pulse-width demodulation is enabled.</p>
[TMROUT0] [TMROUT1]	PIO28 PIO1	O O	<p>Timer Outputs 1–0 supply the system with either a single pulse or a continuous waveform with a programmable duty cycle. [TMROUT1]–[TMROUT0] are three-stated during bus-hold or reset conditions.</p>
ASYNCHRONOUS SERIAL PORTS (UART AND HIGH-SPEED UART)			
UART			
[RXD_U]	PIO26	STI	Receive Data UART is the asynchronous serial receive data signal that supplies data from the asynchronous serial port to the microcontroller.
[TXD_U]	PIO20	O	Transmit Data UART is the asynchronous serial transmit data signal that supplies data to the asynchronous serial port from the microcontroller.

Table 4. Signal Descriptions (Continued)

Signal Name	Multiplexed Signal(s)	Type	Description
[$\overline{\text{CTS_U}}$]	PIO24	STI	Clear-To-Send UART provides the Clear-to-Send signal from the asynchronous serial port when hardware flow control is enabled for the port. The [$\overline{\text{CTS_U}}$] signal gates the transmission of data from the serial port transmit shift register. When [$\overline{\text{CTS_U}}$] is asserted, the transmitter begins transmission of a frame of data, if any is available. If [$\overline{\text{CTS_U}}$] is deasserted, the transmitter holds the data in the serial port transmit shift register. The value of [$\overline{\text{CTS_U}}$] is checked only at the beginning of the transmission of the frame. [$\overline{\text{CTS_U}}$] and [$\overline{\text{RTR_U}}$] form the hardware handshaking interface for the UART.
[$\overline{\text{RTR_U}}$]	PIO25	O	Ready-To-Receive UART provides the Ready-to-Receive signal for the asynchronous serial port when hardware flow control is enabled for the port. The [$\overline{\text{RTR_U}}$] signal is asserted when the associated serial port receive data register does not contain valid, unread data. [$\overline{\text{CTS_U}}$] and [$\overline{\text{RTR_U}}$] form the hardware handshaking interface for the UART.
HIGH-SPEED UART			
[RXD_HU]	PIO16	STI	Receive Data High-Speed UART is the asynchronous serial receive data signal that supplies data from the high-speed serial port to the microcontroller.
TXD_HU	—	O	Transmit Data High-Speed UART is the asynchronous serial transmit data signal that supplies data to the high-speed serial port from the microcontroller.
[$\overline{\text{CTS_HU}}$]	PIO46	STI	Clear-To-Send High-Speed UART provides the Clear-to-Send signal from the high-speed asynchronous serial port when hardware flow control is enabled for the port. The [$\overline{\text{CTS_HU}}$] signal gates the transmission of data from the serial port transmit shift register. When [$\overline{\text{CTS_HU}}$] is asserted, the transmitter begins transmission of a frame of data, if any is available. If [$\overline{\text{CTS_HU}}$] is deasserted, the transmitter holds the data in the serial port transmit shift register. The value of [$\overline{\text{CTS_HU}}$] is checked only at the beginning of the transmission of the frame. [$\overline{\text{CTS_HU}}$] and [$\overline{\text{RTR_HU}}$] form the hardware handshaking interface for the High-Speed UART.
[$\overline{\text{RTR_HU}}$]	PIO47	O	Ready-To-Receive High-Speed UART provides the Ready-to-Receive signal to the high-speed asynchronous serial port when hardware flow control is enabled for the port. The [$\overline{\text{RTR_HU}}$] signal is asserted when the associated serial port receive data register does not contain valid, unread data. [$\overline{\text{CTS_HU}}$] and [$\overline{\text{RTR_HU}}$] form the hardware handshaking interface for the High-Speed UART.
SYNCHRONOUS SERIAL INTERFACE (SSI)			
[SCLK]	PIO11	O	Serial Clock provides the clock for the synchronous serial interface to allow synchronous transfers between the microcontroller and a slave device.
[SDATA]	PIO12	B	Serial Data is used to transmit and receive data between the microcontroller and a slave device on the synchronous serial interface.
[SDEN]	PIO10	O	Serial Data Enable enables data transfers on the synchronous serial interface.
HIGH-LEVEL DATA LINK CONTROL SYNCHRONOUS COMMUNICATION INTERFACES			
HDLC Channel A (DCE)			
DCE_RXD_A	[PCM_RXD_A]	STI	DCE Receive Data Channel A is the serial data input pin for the channel A DCE interface.
DCE_TXD_A	[PCM_TXD_A]	OD-O	DCE Transmit Data Channel A is the serial data output pin for the channel A DCE interface.
DCE_RCLK_A	[PCM_CLK_A]	STI	DCE Receive Clock Channel A provides the receive clock to the channel A DCE interface. If the same clock is to be used for both transmit and receive, then this pin should be tied to the DCE_TCLK_A pin externally. The DCE function is the default at reset, so the board designer is responsible for properly terminating the DCE_RCLK_A input.

Table 4. Signal Descriptions (Continued)

Signal Name	Multiplexed Signal(s)	Type	Description
DCE_TCLK_A	[PCM_FSC_A]	STI	DCE Transmit Clock Channel A provides the transmit clock to the channel A DCE interface. If the same clock is to be used for both transmit and receive, then this pin should be tied to the DCE_RCLK_A pin externally. The DCE function is the default at reset, so the board designer is responsible for properly terminating the DCE_TCLK_A input.
[DCE_CTS_A]	[PCM_TSC_A] PIO17	STI	DCE Clear-To-Send Channel A indicates to the channel A DCE interface that an external serial interface is ready to receive data. [DCE_CTS_A] and [DCE_RTR_A] provide the handshaking for the channel A DCE interface.
[DCE_RTR_A]	PIO18	O	DCE Ready-to-Receive Channel A indicates to an external serial interface that the internal channel A DCE interface is ready to accept data. [DCE_CTS_A] and [DCE_RTR_A] provide the handshaking for the channel A DCE interface.
HDLC Channel B (DCE)			
[DCE_RXD_B]	[PCM_RXD_B] PIO36	STI	DCE Receive Data Channel B is the serial data input pin for the channel B DCE interface.
[DCE_TXD_B]	[PCM_TXD_B] PIO37	OD-O	DCE Transmit Data Channel B is the serial data output pin for the channel B DCE interface.
[DCE_RCLK_B]	[PCM_CLK_B] PIO40	STI	DCE Receive Clock Channel B provides the receive clock to the channel B DCE interface. If the same clock is to be used for both transmit and receive, this pin should be tied to the [DCE_TCLK_B] pin externally.
[DCE_TCLK_B]	[PCM_FSC_B] PIO41	STI	DCE Transmit Clock Channel B provides the transmit clock to the channel B DCE interface. If the same clock is to be used for both transmit and receive, this pin should be tied to the [DCE_RCLK_B] pin externally.
[DCE_CTS_B]	[PCM_TSC_B] PIO38	STI	DCE Clear-To-Send Channel B indicates to the channel B DCE interface that an external serial interface is ready to receive data. [DCE_CTS_B] and [DCE_RTR_B] provide the handshaking for the channel B DCE interface.
[DCE_RTR_B]	PIO39	O	DCE Ready-to-Receive Channel B indicates to an external serial interface that the internal channel B DCE interface is ready to accept data. [DCE_CTS_B] and [DCE_RTR_B] provide the handshaking for the channel B DCE interface.
HDLC Channel A (PCM)			
[PCM_RXD_A]	DCE_RXD_A	STI	PCM Receive Data Channel A is the serial data input pin for the channel A PCM Highway interface.
[PCM_TXD_A]	DCE_TXD_A	O-LS-OD	PCM Transmit Data Channel A is the serial data output pin for the channel A PCM Highway interface.
[PCM_CLK_A]	DCE_RCLK_A	STI	PCM Clock is the single transmit and receive data clock pin for the channel A PCM Highway interface.
[PCM_FSC_A]	DCE_TCLK_A	STI	PCM Frame Synchronization Clock provides the Frame Synchronization Clock input (usually 8 kHz) for the channel A PCM Highway interface.
[PCM_TSC_A]	[DCE_CTS_A] PIO17	OD	PCM Time Slot Control A enables an external buffer device when channel A PCM Highway data is present on the [PCM_TXD_A] output pin in PCM Highway mode.
HDLC Channel B (PCM)			
[PCM_RXD_B]	[DCE_RXD_B] PIO36	STI	PCM Receive Data Channel B is the serial data input pin for the channel B PCM Highway interface.
[PCM_TXD_B]	[DCE_TXD_B] PIO37	O-LS-OD	PCM Transmit Data Channel B is the serial data output pin for the channel B PCM Highway interface.
[PCM_CLK_B]	[DCE_RCLK_B] PIO40	STI	PCM Clock is the single transmit and receive data clock pin for the channel B PCM Highway interface.
[PCM_FSC_B]	[DCE_TCLK_B] PIO41	STI	PCM Frame Synchronization Clock provides the Frame Synchronization Clock input (usually 8 kHz) for the channel B PCM Highway interface.
[PCM_TSC_B]	[DCE_CTS_B] PIO38	OD	PCM Time Slot Control B enables an external buffer device when channel B PCM Highway data is present on the [PCM_TXD_B] output pin in PCM Highway mode.

ARCHITECTURAL OVERVIEW

The architectural goal of the Am186CH HDLC microcontroller is to provide comprehensive communications features on a processor running the widely known x86 instruction set. The Am186CH HDLC microcontroller combines two HDLC channels and general communications peripherals with the Am186

microcontroller. This highly integrated microcontroller provides system cost and performance advantages for a wide range of communications applications. Figure 1 is a block diagram of the Am186CH HDLC microcontroller followed by sections providing an overview of the features.

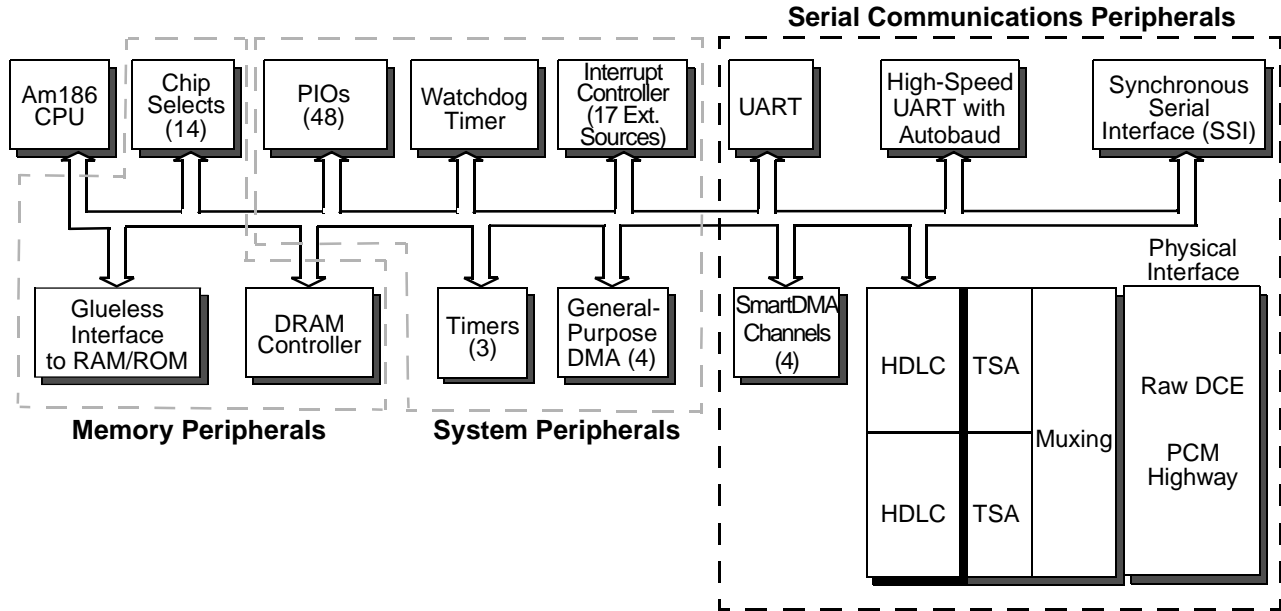

Figure 1. Am186CH Microcontroller Block Diagram

Detailed Description

■ Two independent High-level Data Link Control (HDLC) channels support a wide range of external interfaces

- External interface connection for HDLCs can be PCM Highway or raw DCE
- Data rate of up to 10 Mbit/s
- Receive and transmit FIFOs
- Support for HDLC, Synchronous Data Link Control (SDLC), Line Access Procedure Balanced (LAP-B), Line Access Procedure D (LAP-D), Point-to-Point Protocol (PPP), and v.120 (support of v.110 In transparent mode)
- Two dedicated buffer descriptor ring SmartDMA channels per HDLC
- One independent time-slot assigner per HDLC
- Clear-to-Send/Ready-to-Receive (CTS/RTR) hardware handshaking and auto-enable operation
- Collision detection for multidrop applications
- Transparency mode
- Address comparison on receive
- Flag or mark idle operation

■ Two independent Time Slot Assigners (TSAs) provide flexible time slot allocation

- Allows isolation of Time Division Multiplexed (TDM) time slot of choice from a variety of TDM carriers
- Up to 4096 sequential bits can be isolated
- TDM bus can have up to 512 8-bit time slots
- Start bit and stop bit times identify isolated portion of TDM frame
- 12-bit counters define the start/stop bit times as the number of bits after frame synchronization
- Entire frame down to 1 bit per frame can be isolated

■ 8 Direct Memory Access (DMA) channels

- Four buffer descriptor ring SmartDMA channels for the two HDLC channels
- Four general-purpose DMAs support the two integrated asynchronous serial ports; two DMA channels have external DMA request inputs

■ **High-speed asynchronous serial interface provides enhanced UART functions**

- Capable of sustained operation at 460 Kbaud
- 7-, 8-, or 9-bit data transfers
- FIFOs to support high-speed operation
- DMA support available
- Automatic baud-rate detection that allows emulation of a Hayes AT-compatible modem
- Independent baud generator with clock input source programmable to use CPU or external clock input pin

■ **Asynchronous serial interface (UART)**

- 7-, 8-, or 9-bit data transfers
- DMA support available

- Independent baud generator with clock input source programmable to use CPU or external clock input pin

■ **Synchronous Serial Interface (SSI) provides half-duplex, bidirectional interface to high-speed peripherals**

- Useful with many telecommunication interface peripherals such as codecs, line interface units, and transceivers
- Selectable device-select polarity
- Selectable bit shift order on transmit and receive
- Glueless connection to AMD Subscriber Line Audio Processing Circuit (SLACT™) devices

■ **Clocking options offer high flexibility**

- CPU can run in 1x, 2x, or 4x mode

Am186™ Embedded CPU

All members of the Am186 family, including the Am186CH HDLC microcontroller, are compatible with the original industry-standard 186 parts, and build on the same core set of 186 registers, address generation, I/O space, instruction set, segments, data types, and addressing modes.

Memory Organization

Memory is organized in sets of segments. Each segment is a linear contiguous sequence of 64K (2^{16}) 8-bit bytes. Memory is addressed using a two-component address consisting of a 16-bit segment value and a 16-bit offset. The 16-bit segment values are contained in one of four internal segment registers (CS, DS, SS, or ES). The physical address is calculated by shifting the segment value left by 4 bits

and adding the 16-bit offset value to yield a 20-bit physical address (see Figure 2). This allows for a 1-Mbyte physical address size.

All instructions that address operands in memory must specify the segment value and the 16-bit offset value. For speed and compact instruction encoding, the segment register used for physical address generation is implied by the addressing mode used (see Table 5 on page 26).

I/O Space

The I/O space consists of 64K 8-bit or 32K 16-bit ports. Separate instructions (IN/INS and OUT/OUTS) address the I/O space with either an 8-bit port address specified in the instruction, or a 16-bit port address in the DX register. Eight-bit port addresses are zero-extended such that A15–A8 are Low.

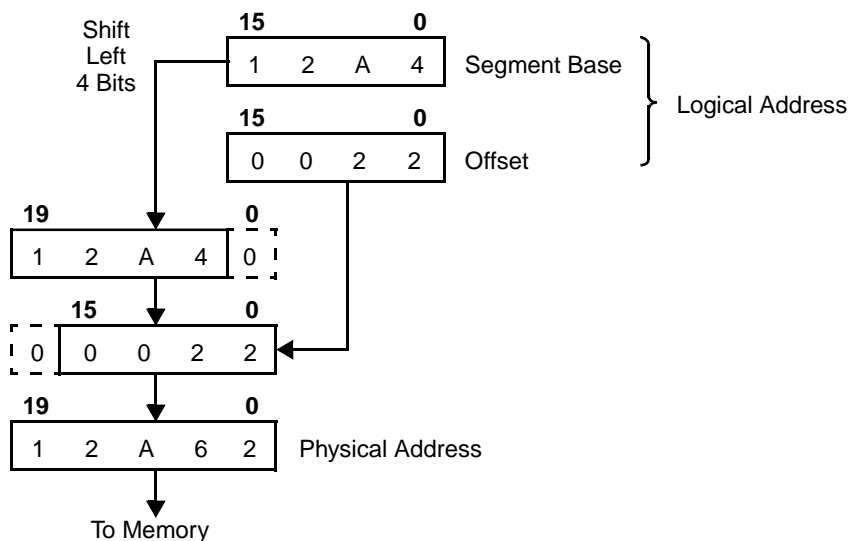

Figure 2. Two-Component Address Example

Table 5. Segment Register Selection Rules

Memory Reference Needed	Segment Register Used	Implicit Segment Selection Rule
Instructions	Code (CS)	Instructions (including immediate data)
Local Data	Data (DS)	All data references
Stack	Stack (SS)	All stack pushes and pops; any memory references that use the BP register
External Data (Global)	Extra (ES)	All string instruction references that use the DI register as an index

Serial Communications Support

The Am186CH HDLC microcontroller supports five serial interfaces. This includes two HDLC channels, two UARTs, and a synchronous serial interface.

Two HDLC Channels and Two TSAs

The Am186CH HDLC microcontroller provides two HDLC channels that support the HDLC, SDLC, LAP-B, LAP-D, PPP, and v.120 protocols. The HDLC channels can also be used in transparent mode to support v.110. Each HDLC channel can connect to an external serial interface directly (nonmultiplexed mode), or can pass through a TSA (multiplexed mode). The flexible interface multiplexing arrangement allows each HDLC channel to have its own external raw DCE or PCM highway interface, share a common PCM highway or other time TDM bus with one or more channels, or work in some combination.

Each HDLC channel's independent TSA allows it to extract a subset of data from a TDM bus. The entire frame, or as little as 1 bit per frame, can be extracted.

Twelve-bit counters define the start/stop bit times as the number of bits after frame synchronization. The time slot can be an arbitrary number of bits up to 4096 bits. Start bit and stop bit times identify the isolated portion of the TDM frame. Support of less than eight bits per time slot, or *bit slotting*, allows isolation of from one to eight bits in a single time slot. Each TDM bus can have up to 512 8-bit time slots. Support of these features allows interoperability with PCM highway, E1, IOM-2, T1, and other TDM buses.

The HDLC channels have features that make the Am186CH HDLC microcontroller an attractive device for use where general HDLC capability is required. These features include CTS/RTR hardware handshaking and auto-enable operation, collision detection for multidrop applications, transparency mode, address comparison on receive, flag or mark idle operation, two dedicated buffer descriptor ring SmartDMA channels per HDLC, transmit and receive FIFOs, and full-duplex data transfer. Each TSA channel can support a burst data rate to/from the HDLC of up to 10 Mbit/s in both raw DCE and PCM Highway modes. Total system data throughput is highly dependent on the amount of per-packet and per-byte CPU processing, the rate at which packets are being sent, and other CPU activity.

When combined with the TSAs, the HDLC channels can be used in a wide variety of applications such as PCM highway, X.25, Frame Relay, and other proprietary Wide Area Network (WAN) connections.

Four SmartDMA™ Channels

The Am186CH HDLC microcontroller provides four SmartDMA channels that provide a faster method for moving data between peripherals and memory with lower CPU utilization. SmartDMA transmits and receives data across multiple memory buffers and a sophisticated buffer-chaining mechanism. These channels are always used in pairs: transmitter and receiver. The transmit channels can only transfer data from memory to a peripheral; the receive channels can only transfer data from a peripheral to memory.

The four channels (two pairs) are dedicated for use with the two on-board HDLC channels.

In addition to the four SmartDMA channels, the Am186CH HDLC microcontroller provides four general-purpose DMA channels (see page 27).

Two Asynchronous Serial Ports

The Am186CH HDLC microcontroller has two asynchronous serial ports (a UART and a High-Speed UART) that provide full-duplex, bidirectional data transfer at speeds of up to 115.2 Kbaud or up to 460 Kbaud, respectively. The High-Speed UART has 16-byte transmit and 32-byte receive FIFOs, special-character matching, and automatic baud-rate detection, suitable for implementation of a Hayes-compatible modem interface to a host PC. There is also a lower speed UART that typically is used for a low baud-rate system configuration port or debug port. Each of these UARTs can derive its baud rate from the system clock or from a separate baud-rate generator clock input. Both UARTs support 7-, 8-, or 9-bit data transfers; address bit generation and detection in 7- or 8-bit frames; one or two stop bits; even, odd, or no parity; break generation and detection; hardware flow control; and DMA to and/or from the serial ports using the general-purpose DMA channels.

Synchronous Serial Port

The Am186CH HDLC microcontroller includes one SSI port that provides a half-duplex, bidirectional, communications interface between the Am186CH HDLC microcontroller and other system components. This interface is typically used by the microcontroller to monitor the status of other system devices and/or to configure these devices under software control. In a communications application, these devices could be system components such as audio codecs, line interface units, and transceivers. The SSI supports data transfer speeds of up to 25 Mbit/s with a 50-MHz system clock.

The SSI port operates as an interface master, with the other attached devices acting as slave devices. Using this protocol, the microcontroller sends a command byte to the attached device, and then follows that with either a read or write of a byte of data.

The SSI port consists of three I/O pins: an enable (SDEN), a clock (SCLK), and a bidirectional data pin (SDATA). SDEN can be used directly as an enable for a single attached device. When more than one device requires control via the SSI, PIOs can be used to provide enable pins for those devices.

The Am186CH SSI is, in general, software compatible with software written for the Am186EM SSI. (Additional features have been added to the Am186CH SSI implementation.) The Am186CH HDLC microcontroller features the additional capability of selecting the polarity of the SCLK and SDEN pins, as well as the shift order of bits on the SDATA pin (least-significant-bit first versus most-significant-bit first). The SSI port also offers a programmable clock divisor (dividing the clock from 2 to 256 in power of 2 increments), a bidirectional transmit/receive shift register, and direct connection to AMD SLAC devices.

System Peripherals

Interrupt Controller

The Am186CH HDLC microcontroller features an interrupt controller that arranges the 36 maskable interrupt requests by priority and presents them one at a time to the CPU. In addition to interrupts managed by the interrupt controller, the Am186CH HDLC microcontroller supports eight nonmaskable interrupts—an external or internal nonmaskable interrupt (NMI), a trace interrupt, and software interrupts and exceptions.

The interrupt controller supports the 36 maskable interrupt sources through the use of 15 channels. Because of this, most channels support multiple interrupt sources. These channels are programmable to support the external interrupt pins and/or various peripheral devices that can be configured to generate

interrupts. The 36 maskable interrupt sources include 19 internal sources and 17 external sources.

Four General-Purpose DMA Channels

The Am186CH HDLC microcontroller provides a total of 12 DMA channels that can be used for data transfer between memory and I/O spaces (i.e., memory-to-I/O or I/O-to-memory) or within the same space (i.e., memory-to-memory or I/O-to-I/O). In addition, the Am186CH HDLC microcontroller supports data transfer between peripherals and memory or I/O. Internal peripherals that support general-purpose DMA are Timer 2 and the two asynchronous serial ports (UART and High-Speed UART). External peripherals support DMA transfers through the external DMA request pins. Each general-purpose channel can accept synchronized DMA requests from one of three sources: DMA request pins (DRQ1–DRQ0), Timer 2, or the UARTs. In addition, system software can initialize and start unsynchronized DMA transfers.

In addition to the four general-purpose channels, the Am186CH HDLC microcontroller provides four SmartDMA channels (see page 26).

48 Programmable I/O Signals

The Am186CH HDLC microcontroller provides 48 user-programmable input/output signals (PIOs). All but six of the 48 signals share a pin with at least one alternate function. If an application does not need the alternate function, the associated PIO can be used by programming the PIO registers.

If a pin is enabled to function as a PIO signal, the alternate function is disabled and does not affect the pin. A PIO signal can be configured to operate as an input or output, with or without internal pullup or pulldown resistors (pullup or pulldown depends on the pin configuration and is not user-configurable), or as an open-drain output. Additionally, eight PIOs can be configured as external interrupt sources.

Three Programmable Timers

There are three 16-bit programmable timers in the Am186CH HDLC microcontroller. Timers 0 and 1 are highly versatile and are each connected to two external pins (each one has an input and an output). These two timers can be used to count or time external events that drive the timer input pins. Timers 0 and 1 can also be used to generate nonrepetitive or variable-duty-cycle waveforms on the timer output pins.

Timer 2 is not connected to any external pins. It can be used by software to generate interrupts, or it can be polled for real-time coding and time-delay applications. Timer 2 can also be used as a prescaler to Timer 0 and Timer 1, or as a DMA request source.

The source clock for Timer 2 is one-fourth of the system clock frequency. The source clock for Timers 0

and 1 can be configured to be one-fourth of the system clock, or they can be driven from their respective timer input pins. When driven from a timer input pin, the timer is counting the “event” of an input transition.

The Am186CH HDLC microcontroller also provides a pulse width demodulation (PWD) option so that a toggling input signal’s Low state and High state durations can be measured.

Hardware Watchdog Timer

The Am186CH HDLC microcontroller provides a full-featured watchdog timer, which includes the ability to generate Non-Maskable Interrupts (NMIs), microcontroller resets, and system resets when the timeout value is reached. The timeout value is programmable and ranges from 2^{10} to 2^{26} processor clocks.

The watchdog timer is used to regain control when a system has failed due to a software error or to failure of an external device to respond in the expected way. Software errors can sometimes be resolved by recapturing control of the execution sequence via a watchdog-timer-generated NMI. When an external device fails to respond, or responds incorrectly, it may be necessary to reset the controller or the entire system, including external devices. The watchdog timer provides the flexibility to support both NMI and reset generation.

Memory and Peripheral Interface

System Interfaces

The Am186CH HDLC microcontroller bus interface controls all accesses to the peripheral control block (PCB), memory-mapped and I/O-mapped external peripherals, and memory devices. Internal peripherals are accessed by the bus interface through the PCB.

The bus interface features programmable bus sizing; individually selectable chip selects for the upper ($\overline{\text{UCS}}$) memory space, lower ($\overline{\text{LCS}}$) memory space, all non- $\overline{\text{UCS}}$, non- $\overline{\text{LCS}}$ and I/O memory spaces; separate byte-write enables; and, boot option from an 8- or 16-bit device.

The integrated peripherals are controlled by 16-bit read/write registers. The peripheral registers are contained within an internal 1-Kbyte control block. At reset, the base of the PCB is set to FC00h in I/O space. The registers are physically located in the peripheral devices they control, but they are addressed as a single 1-Kbyte block. For details on the PCB registers, refer to the *Am186™CC/CH/CU Microcontrollers Register Set Manual*, order #21916.

Accesses to the PCB should be performed by direct processor actions. The use of DMA to write or read from the PCB results in unpredictable behavior, except where explicit exception is made to support a peripheral function, such as the High-Speed UART transmit and receive data registers.

The 80C186 and 80C188 microcontrollers use a multiplexed address and data (AD) bus. The address is present on the AD bus only during the t_1 clock phase. The Am186CH HDLC microcontroller continues to provide the multiplexed AD bus and, in addition, provide a nonmultiplexed address (A) bus. The A bus provides an address to the system for the complete bus cycle (t_1 – t_4). During refresh cycles, the AD bus is driven during the t_1 phase and the values are unknown during the t_2 , t_3 , and t_4 phases. The value driven on the A bus is undefined during a refresh cycle.

The nonmultiplexed address bus (A19–A0) is valid one-half CLKOUT cycle in advance of the address on the AD bus. When used with the modified UCS and LCS outputs and the byte write enable signals, the A19–A0 bus provides a seamless interface to SRAM, DRAM, and Flash/EPROM memory systems.

For systems where power consumption is a concern, it is possible to disable the address from being driven on the AD bus on the Am186CH HDLC microcontroller during the normal address portion of the bus cycle for accesses to upper ($\overline{\text{UCS}}$) and/or lower ($\overline{\text{LCS}}$) address spaces. In this mode, the affected bus is placed in a high-impedance state during the address portion of the bus cycle. This feature is enabled through the DA bits in the Upper Memory Chip Select (UMCS) and Lower Memory Chip Select (LMCS) registers.

When address disable is in effect, the number of signals that assert on the bus during all normal bus cycles to the associated address space is reduced, thus decreasing power consumption, reducing processor switching noise, and preventing bus contention with memory devices and peripherals when operating at high clock rates.

If the $\overline{\text{ADEN}}$ pin is asserted during processor reset, the value of the DA bits in the UMCS and LMCS registers is ignored and the address is driven on the AD bus for all accesses, thus preserving the industry-standard 80C186 and 80C188 microcontrollers’ multiplexed address bus and providing support for existing emulation tools. For details on these registers, refer to the *Am186™CC/CH/CU Microcontrollers Register Set Manual*, order #21916.

Figure 3 on page 29 shows the affected signals during a normal read or write operation. The address and data are multiplexed onto the AD bus.

Figure 4 on page 29 shows a bus cycle when address bus disable is in effect, which causes the AD bus to operate in a nonmultiplexed data-only mode. The A bus has the address during a read or write operation.

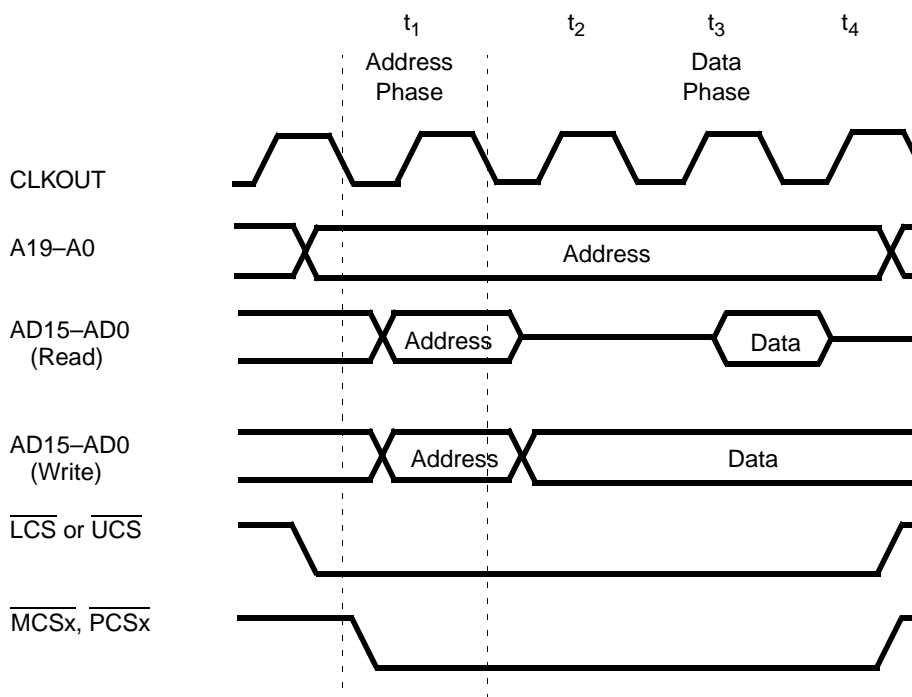

Figure 3. Am186CH Microcontroller Address Bus — Default Operation

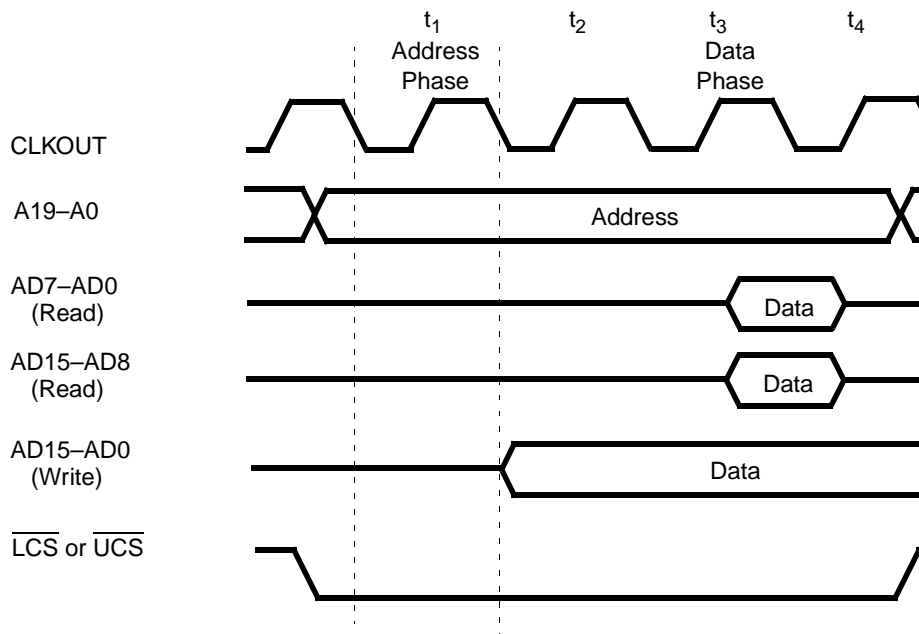

Figure 4. Am186CH Microcontroller—Address Bus Disable In Effect

Bus Interface

The bus interface controls all accesses to external peripherals and memory devices. External accesses include those to memory devices, as well as those to memory-mapped and I/O-mapped peripherals and the peripheral control block. The Am186CH HDLC microcontroller provides an enhanced bus interface unit with the following features:

- Nonmultiplexed address bus
- Separate byte write enables for high and low bytes
- Output enable

The standard 80C186/80C188 multiplexed address and data bus requires system interface logic and an external address latch. On the Am186CH HDLC microcontroller, byte write enables and a nonmultiplexed address bus can reduce design costs by eliminating this external logic.

Nonmultiplexed Address Bus

The nonmultiplexed address bus (A19–A0) is valid one-half CLKOUT cycle in advance of the address on the AD bus. When used with the modified UCS and LCS outputs and the byte write enable signals, the A19–A0 bus provides a seamless interface to external SRAM, and Flash memory/EPROM systems.

Byte Write Enables

The Am186CH HDLC microcontroller provides the $\overline{\text{WHB}}$ (Write High Byte) and $\overline{\text{WLB}}$ (Write Low Byte) signals that act as byte write enables.

$\overline{\text{WHB}}$ is the logical OR of $\overline{\text{BHE}}$ and $\overline{\text{WR}}$. $\overline{\text{WHB}}$ is Low when both $\overline{\text{BHE}}$ and $\overline{\text{WR}}$ are Low. $\overline{\text{WLB}}$ is the logical OR of A0 and $\overline{\text{WR}}$. $\overline{\text{WLB}}$ is Low when A0 and $\overline{\text{WR}}$ are both Low.

The byte write enables are driven with the nonmultiplexed address bus as required for the write timing requirements of common SRAMs.

Output Enable

The Am186CH HDLC microcontroller provides the $\overline{\text{RD}}$ (Read) signal that acts as an output enable for memory or peripheral devices. The $\overline{\text{RD}}$ signal is Low when a word or byte is read by the microcontroller.

DRAM Support

To support DRAM, the Am186CH HDLC microcontroller has a fully integrated DRAM controller that provides a glueless interface to 25–70-ns Extended Data Out (EDO) DRAM. (EDO DRAM is sometimes called Hyper-Page Mode DRAM.) Up to two banks of 4-Mbit (256 Kbit x 16 bit) DRAM can be accessed. Page Mode DRAM, Fast Page Mode DRAM, Asymmetrical DRAM, and 8-bit wide DRAM are not supported. The microcontroller provides zero-wait state operation at up to 50 MHz with 40-ns DRAM. This allows designs requiring larger amounts of memory to

save system cost over SRAM designs by taking advantage of low DRAM memory costs.

The DRAM interface uses various chip select pins to implement the RAS/CAS interface required by DRAMs. The DRAM controller drives the $\overline{\text{RAS}}$ /CAS interface appropriately during both normal memory accesses and during refresh. All signals required are generated by the microcontroller and no external logic is required.

The DRAM multiplexed address pins are connected to the odd address pins of the Am186CH HDLC microcontroller, starting with A1 on the Am186CH HDLC microcontroller connecting to MA0 on the DRAM. The correct row and column addresses are generated on these odd address pins during a DRAM access.

The $\overline{\text{RAS}}$ pins are multiplexed with $\overline{\text{LCS}}$ and $\overline{\text{MCS3}}$, allowing a DRAM bank to be present in either high or low memory space. The $\overline{\text{MCS1}}$ and $\overline{\text{MCS2}}$ function as the upper and lower CAS pins, respectively, and define which byte of data in a 16-bit DRAM is being accessed.

The microcontroller supports the most common DRAM refresh option, CAS-Before-RAS. All refresh cycles contain three wait states to support the DRAMs at various frequencies. The DRAM controller never performs a burst access. All accesses are single accesses to DRAM. If the PCS chip selects are decoded to be in the DRAM address range, PCS accesses take precedence over the DRAM.

Chip Selects

The Am186CH HDLC microcontroller provides six chip select outputs for use with memory devices and eight more for use with peripherals in either memory or I/O space. The six memory chip selects can be used to address three memory ranges. Each peripheral chip select addresses a 256-byte block offset from a programmable base address.

The microcontroller can be programmed to sense a ready signal for each of the peripheral or memory chip select lines. A bit in each chip select control register determines whether the external ready signal is required or ignored.

The chip selects can control the number of wait states inserted in the bus cycle. Although most memory and peripheral devices can be accessed with three or less wait states, some slower devices cannot. This feature allows devices to use wait states to slow down the bus.

The chip select lines are active for all memory and I/O cycles in their programmed areas, whether they are generated by the CPU or by the integrated DMA unit.

General enhancements over the original 80C186 include bus mastering (three-state) support for all chip selects and activation only when the associated register is written, not when it is read.

Clock Control

The processor supports clock rates from 16 to 50 MHz using an integrated crystal oscillator and PLL. Commercial and industrial temperature ratings are available. The CPU can run in 1x, 2x, or 4x PLL mode.

In-Circuit Emulator Support

Because pins are an expensive resource, many play a dual role, and the programmer selects PIO operation or an alternate function. However, a pin configured to be a PIO may also be required for emulation support. Therefore, it is important that before a design is committed to hardware, a user should contact potential emulator suppliers for a list of their emulator's pin

requirements. The following PIO signals are multiplexed with alternate signals that may be used by emulators: PIO8, PIO15, PIO33–PIO35.

The Am186CH HDLC microcontroller was designed to minimize conflicts. In most cases, pin conflict is avoided. For example, if the ALE signal is required for multiplex bus support, then it is not programmed as PIO33. If the multiplexed AD bus is not used, then ALE can be programmed as a PIO pin. And if the multiplexed bus is not in use, then the emulator does not require the ALE signal. However, an emulator is likely to always use the de-multiplexed address, regardless of how the AD bus is programmed.

APPLICATIONS

The Am186CH HDLC microcontroller with its integrated HDLC and other communications features provides a highly integrated, cost-effective solution for a wide range of telecommunications and networking applications.

- **Linecard Applications:** Typically, the microcontroller linecards used in Central Offices (COs), PABX equipment, and other telephony applications require one or two channels of HDLC. Linecard manufacturers are moving to more lines per card for analog POTS as a means of cost reduction. This and digital linecards often require higher performance than existing 8-bit devices can offer. The Am186CH HDLC microcontroller is an ideal solution for these applications because it integrates much of the necessary glue logic while providing higher performance.
- **Industrial Control:** Embedded x86 processors have long been used in the industrial control market. These applications often require a robust, high-performance processor solution with the capability to easily communicate with other parts of a system. The Am186CH HDLC microcontroller provides numerous interfaces to achieve this communication, including the SSI interface, high-speed UART, and the HDLC channels that also can be used to create a multidrop backplane.
- **General Communications Applications:** The Am186CH HDLC microcontroller will also find a home in general embedded applications, because many devices will incorporate communications capability in the future. Many designs are adding HDLC capability as a robust means of inter- and intra-system communications. The microcontroller is especially attractive for 186 designs adding HDLC.

Figure 5 on page 32 shows a 32-channel linecard system application.

The 32-channel linecard design demonstrates the Am186CH HDLC microcontroller's use in a linecard application where 32 incoming POTS lines are aggregated onto a single E1 connection.

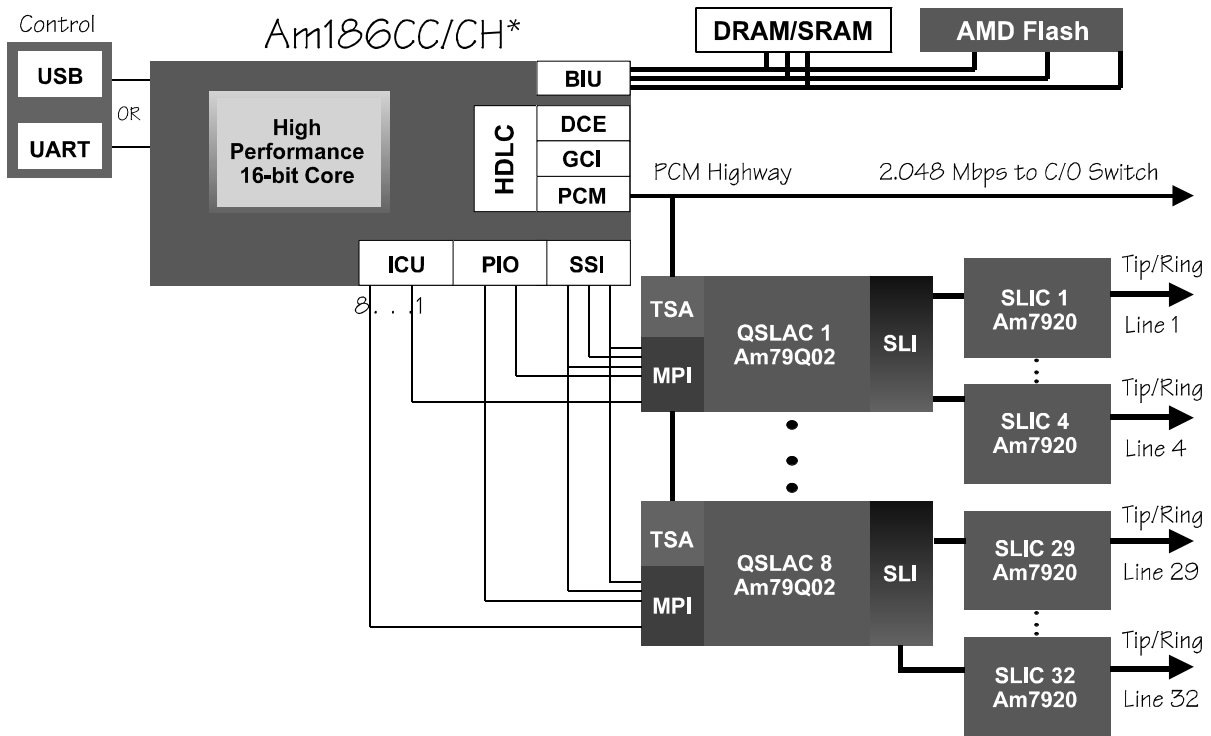

*The Am186CH HDLC microcontroller does not have a USB peripheral controller or a GCI interface.

Figure 5. 32-Channel Linecard System Application

CLOCK GENERATION AND CONTROL

The Am186CH HDLC microcontroller clocks include the general system clock (CLKOUT), transmitter/receiver clocks for each HDLC channel, and the baud rate generator clock for UART and High-Speed UART.

The SSI and the timers (Timers 0, 1, and 2) derive their clocks from the system clock.

Features

The Am186CH HDLC microcontroller clocks include the following features and characteristics:

- A crystal-controlled oscillator that uses an external fundamental mode crystal or oscillator to generate the system input clock.
- An internal PLL that generates a system clock (CLKOUT) that is 1x, 2x, or 4x the system input clock.
- Each HDLC receives its clock inputs directly from the external communication clock pins (TCLK_X and RCLK_X) in all modes. The system clock must be at least the same frequency as any HDLC clock.
 - HDLC DCE and PCM modes support clocks up to 10 MHz.
- SSI clock (SCLK) is derived from the system clock, divided by 2, 4, 8, 16, 32, 64, 128, or 256.
- Timers 0 and 1 can be configured to be driven by the timer input pins (TMRIN1, TMRIN0) or at one-fourth of the system clock. Timer 2 is driven at one-fourth of the system clock.

- UART clock can be derived from the internal system clock frequency or from the UART clock (UCLK) input.

See Figure 6 for a diagram of the basic clock generation and Figure 7 on page 34 for suggested clock frequencies and modes.

System Clock

The system PLL generates frequencies from 16 to 50 MHz. The reference for the system PLL can vary from 8 to 40 MHz, depending on the PLL mode selected and the desired system frequency (see Figure 7 on page 34).

The system PLL modes are chosen by the state of the {CLKSEL1} and {CLKSEL2} pins during reset. For these pinstrap settings see Table 26, “Reset Configuration Pins (Pinstraps),” on page A-7.

The system clock can be generated in one of two ways:

- Using the internal PLL running at 1x, 2x, or 4x the reference clock. The reference clock can be generated from an external crystal using the integrated oscillator or an external oscillator input.
- Bypassing the internal PLL. The external reference generated from either a crystal or an external oscillator input is used to generate the system clock (see “PLL Bypass Mode” on page 35).

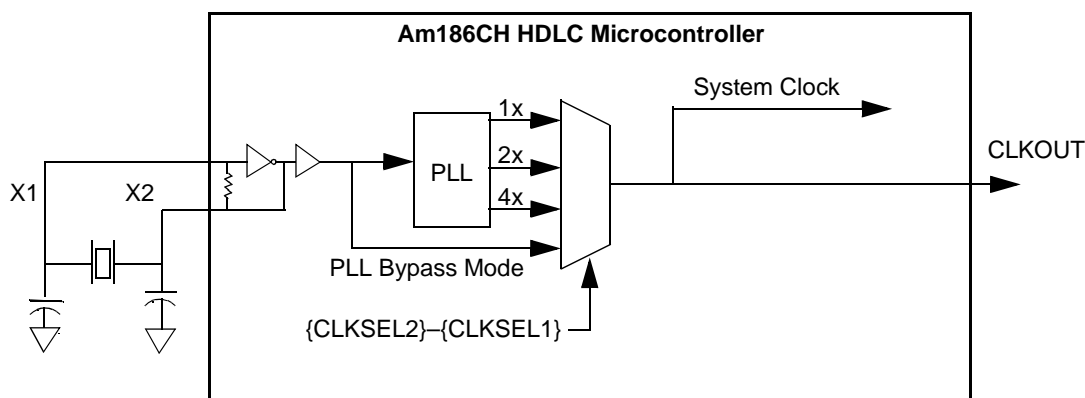

Figure 6. System Clock Generation

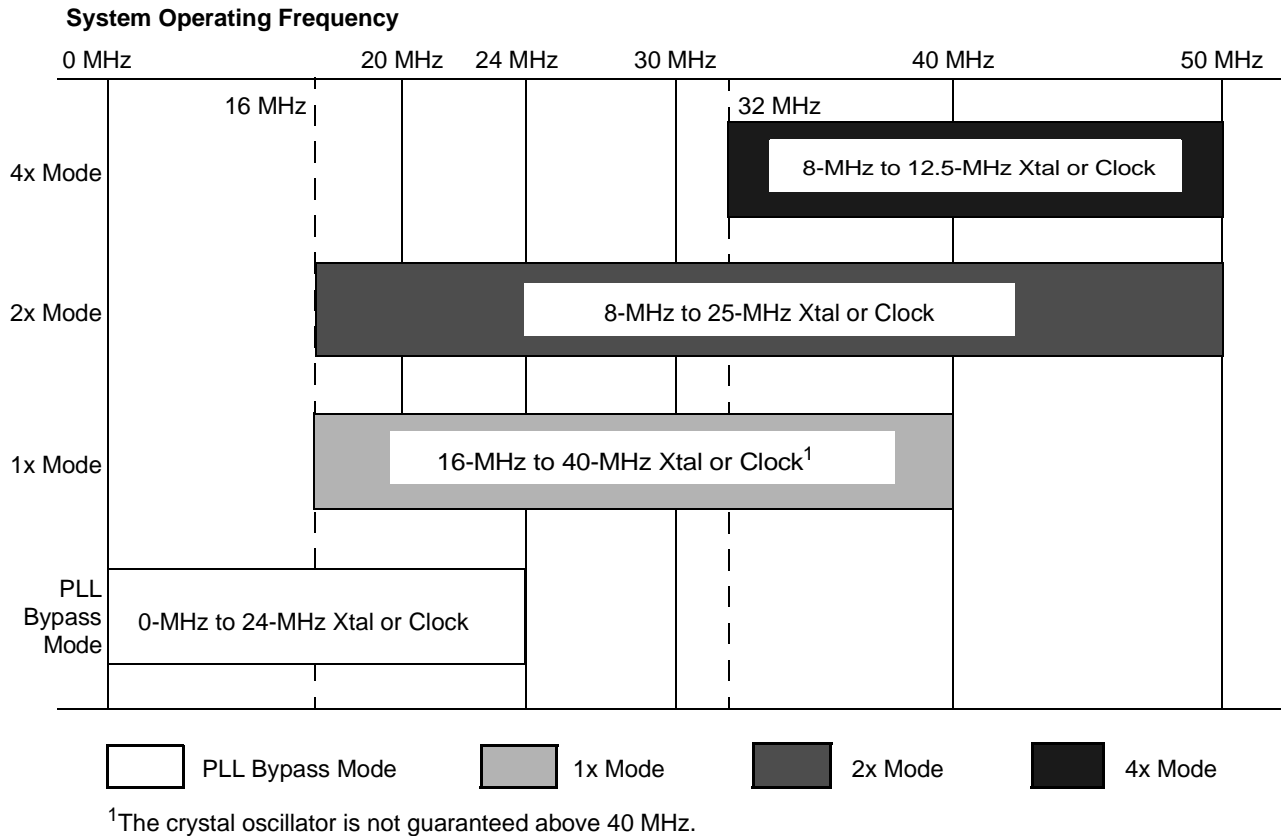

Figure 7. Suggested System Clock Frequencies, Clock Modes, and Crystal Frequencies

Crystal-Driven Clock Source

The internal oscillator circuit is designed to function with an external parallel-resonant fundamental mode crystal. The crystal frequency can vary from 8 to 40 MHz, depending on the PLL mode selected and desired system frequency.

When selecting a crystal, the load capacitance should always be specified (C_L). This value can cause variance in the oscillation frequency from the desired specified value (resonance). The load capacitance and the loading of the feedback network have the following relationship:

$$C_L = \frac{(C_1 \cdot C_2)}{(C_1 + C_2)} + C_S$$

where C_S is the stray capacitance of the circuit.

Table 6 shows crystal parameter values. Figure 8 shows the system clocks using an external crystal and the integrated oscillator. The specific values for C_1 and C_2 must be determined by the designer and are dependent on the characteristics of the chosen crystal and board design.

Table 6. Crystal Parameters

Parameter	Min. Value	Max. Value	Units
Frequency	8	40	MHz
ESR			
8–24 MHz	20	90	ohms
24–50 MHz	20	60	ohms
Load capacitance	10	—	pF

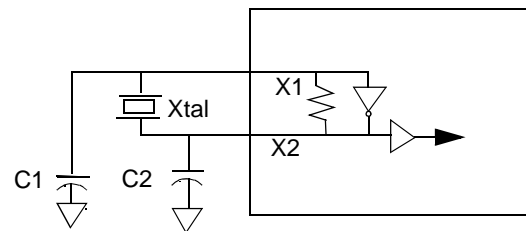

Figure 8. External Interface to Support Clocks—Fundamental Mode Crystal

External Clock Source

The internal oscillator also can be driven by an external clock source. The external clock source should be connected to the input of the inverting amplifier (X1) with the output (X2) left unconnected. Figure 9 shows the system clocks using an external clock source (oscillator bypass).

Note: X1 and X2 are not 5-V tolerant and have a maximum input equal to V_{CC} .

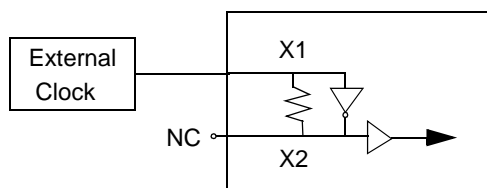

Figure 9. External Interface to Support Clocks—External Clock Source

Static Operation

The Am186CH HDLC microcontroller is a fully static design and can be placed in static mode by stopping the input clock. See the PLL Bypass Mode discussion below.

Note: It is the responsibility of the system designer to ensure that no short clock phases are generated when starting or stopping the clock.

PLL Bypass Mode

The Am186CH HDLC microcontroller provides a PLL Bypass mode that allows the X1 input frequency to be anywhere from 0 to 24 MHz. When the microcontroller is in PLL Bypass mode, the CLKOUT frequency equals the X1 input frequency. This mode must be used with

an external clock source. For PLL Bypass Mode enabling, see Table 26, “Reset Configuration Pins (Pinstraps),” on page A-7.

When changing frequency in PLL Bypass mode, the X1 input must not have any short or “runt” pulses. At 24 MHz, the nominal High/Low time is 21 ns. The actual High times and Low times must not fall below 16 ns. These values allow a 60%/40% duty cycle at X1.

In the Am186CH microcontroller, the system clock must be at the same or a greater frequency than the HDLC clock and UCLK (if using UCLK). Therefore, if reducing the system clock frequency, disable these interfaces or run them at a lower frequency.

UART Baud Clock

The UART and High-Speed UART have two possible clock sources: the system clock or the UCLK input pin. If UCLK is used for the UART clock, the system clock must be at least the same frequency as UCLK. The clock configurations are shown graphically in Figure 10.

The baud clock is generated by dividing the clock source by the value of the baud rate divisor register. The serial port logic can select its baud rate clock from either an external pin (UCLK) or from the system clock.

The system or UCLK clock is selected independent of any other settings.

The formula for determining the baud rate divisor register value is:

$$BAUDDIV = (\text{clock frequency} / (16 \cdot \text{baud rate}))$$

Note: UCLK cannot be clocked at a frequency higher than the system clock frequency.

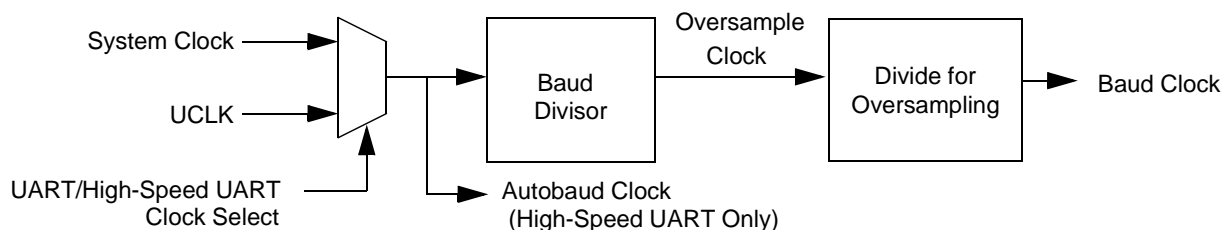

Figure 10. UART and High-Speed UART Clocks

POWER SUPPLY OPERATION

CMOS dynamic power consumption is proportional to the square of the operating voltage multiplied by capacitance and operating frequency. Static CPU operation can reduce power consumption by enabling the system designer to reduce operating frequency when possible. However, operating voltage is always the dominant factor in power consumption. By reducing the operating voltage from 5 V to 3.3 V for any device, the power consumed is reduced by 56%.

Reduction of CPU and system logic operating voltage dramatically reduces overall system power consumption. Additional power savings can be realized as low-voltage mass storage and peripheral devices become available.

Two basic strategies exist in designing systems containing the Am186CH HDLC microcontroller. The first strategy is to design a homogenous system in which all logic components operate at 3.3 V. This provides the lowest overall power consumption. However, system designers may need to include devices for which 3.3-V versions are not available.

In the second strategy, the system designer must then design a mixed 5-V/3.3-V system. This compromise enables the system designer to minimize the system logic power consumption while still including the functionality of the 5-V features. The choice of a mixed voltage system design also involves balancing design complexity with the need for the additional features.

Power Supply Connections

Connect all V_{CC} pins together to the 3.3-V power supply and all ground pins to a common system ground.

Input/Output Circuitry

To accommodate current 5-V systems, the Am186CH HDLC microcontroller has 5-V tolerant I/O drivers. The drivers produce TTL-compatible drive output (minimum 2.4-V logic High) and receive TTL and CMOS levels (up to $V_{CC} + 2.6$ V). The following are some design issues that should be considered with mixed 3.3-V/5-V designs:

- During power-up, if the 3.3-V supply has a significant delay in achieving stable operation relative to 5-V supply, then the 5-V circuitry in the system may start driving the processor's inputs above the maximum levels ($V_{CC} + 2.6$ V). The system design should ensure that the 5-V supply does not exceed 2.6 V above the 3.3-V supply during a power-on sequence.
- Preferably, all inputs are driven by sources that can be three-stated during a system reset condition. The system reset condition should persist until stable V_{CC} conditions are met. This should help ensure that the maximum input levels are not exceeded during power-up conditions.
- Preferably, all pullup resistors are tied to the 3.3-V supply, which ensures that inputs requiring pullups are not over stressed during power-up.

PIO Supply Current Limit

Each programmable I/O output is able to sink or source a sustained 16-mA drive current. However, only 40 mA of sustained PIO current is allowed for each supply pin (V_{CC}), and only 60 mA is allowed for each ground pin (V_{SS}).

To calculate the PIO current for each supply or ground pin, sum the applicable current (source or sink) of all PIO pins on either side of the pin (to the adjacent corresponding pins), and divide the sum by two. The resulting value should not exceed 40 mA for V_{CC} or 60 mA for V_{SS} .

Exclude the following pins from this calculation: 72 (V_{SS_A}), 82 (V_{SS}), 77 (V_{CC_A}), and 79 (V_{CC}).

For example, to calculate the PIO current for pin 83 (V_{SS}), total the sustained sinking current for all PIO pins between pin 71 (V_{SS}) and pin 100 (V_{SS}), and divide the sum by two.

ABSOLUTE MAXIMUM RATINGS¹

Parameter	Symbol	Minimum	Maximum	Unit
Temperature under bias: commercial	T_C ²	0	100	°C
Industrial	T_A ³	-40	+85	°C
Storage temperature	—	-65	+150	°C
Voltage on 5-V-tolerant pins ⁴ with respect to ground	—	-0.5	$V_{CC} + 2.6$	V
Voltage on other pins with respect to ground	—	-0.5	$V_{CC} + 0.5$	V
Sustained current on any supply (V_{CC}) pin ⁵	—	40	—	mA
Sustained PIO current on any ground (V_{SS}) pin ⁵	—	60	—	mA

Notes:

1. Stresses above those listed under Absolute Maximum Ratings can cause permanent device failure. Functionality at or above these limits is not implied. Exposure to absolute maximum ratings for extended periods may affect device reliability.
2. T_C = case temperature.
3. T_A = ambient temperature.
4. 5-V-tolerant pins are indicated in Table 30, "Pin List Summary," on page A-11.
5. See "PIO Supply Current Limit" on page 36.

OPERATING RANGES¹

Parameter	Symbol	Minimum	Maximum	Unit
Commercial	T_C ²	0	100	°C
Industrial	T_A ³	-40	+85	°C
Supply voltage with respect to ground	V_{CC}	3.0	3.6	V

Notes:

1. Operating Ranges define those limits between which the functionality of the device is guaranteed.
2. T_C = case temperature.
3. T_A = ambient temperature.

DC CHARACTERISTICS OVER COMMERCIAL AND INDUSTRIAL OPERATING RANGES¹

Symbol	Parameter	Preliminary		Unit
		Minimum	Maximum	
V_{OH}	Output High voltage ($I_{OH} = -2.4$ mA)	2.4	—	V
V_{OH}	Output High voltage ($I_{OH} = -0.1$ mA) ²	$V_{CC} - 0.2$	—	V
V_{OL}	Output Low voltage ($I_{OL} = 4.0$ mA)	—	0.45	V
V_{IH5}	5-V tolerant Input High voltage	2.0	$V_{CC} + 2.6$	V
V_{IH}	Input High voltage, except 5-V tolerant	2.0	$V_{CC} + 0.3$	V
V_{IL}	Input Low voltage	-0.3	0.8	V
I_{LI}	Input leakage current (0.1 V $\leq V_{OUT} \leq V_{CC}$) (all pins except those with internal pullup/pulldown resistors)	—	± 10	μ A
I_{LO}	Output leakage current ³ (0.1 V $\leq V_{OUT} \leq V_{CC}$)	—	± 15	μ A
P_{CC}	Power consumption	—	1.2	W

Notes:

1. Current out of pin is stated as a negative value.
2. Characterized but not tested.
3. This parameter is for three-state outputs where V_{OUT} is driven on the three-state output.

CAPACITANCE

Symbol	Parameter	Preliminary		Unit
		Minimum	Maximum	
C _{IN}	Input capacitance	—	15	pF
C _{CLK}	Clock capacitance	—	15	pF
C _{OUT}	Output capacitance	—	20	pF
C _{I/O}	I/O pin capacitance	—	20	pF

MAXIMUM LOAD DERATING

All maximum delay numbers should be increased by 0.035 ns for every pF of load over the maximum load (up to a maximum of 150 pF) specified in Table 30, “Pin List Summary,” on page A-11.

POWER SUPPLY CURRENT

For the following typical system specification shown in Figure 11, I_{CC} has been measured at 6 mA per MHz of system clock. The typical system is measured while the system is executing code in a typical application with nominal voltage and maximum case temperature. Actual power supply current is dependent on system design and may be greater or less than the typical I_{CC} figure presented here.

Typical current in Figure 11 is given by:

$$I_{CC} = 6 \text{ mA} \cdot \text{freq}(\text{MHz})$$

Please note that dynamic I_{CC} measurements are dependent upon chip activity, operating frequency, output buffer logic, and capacitive/resistive loading of the outputs. For these I_{CC} measurements, the devices were set to the following modes:

- No DC loads on the output buffers
- Output capacitive load set to 30 pF
- AD bus set to data only
- PIOs are disabled
- Timer, serial port, refresh, and DMA are enabled

Table 7 shows the values that are used to calculate the typical power consumption value for the Am186CH HDLC microcontroller.

Table 7. Typical Power Consumption Calculation

MHz · I _{CC} · Volts / 1000 = P			Typical Power in Watts
MHz	Typical I _{CC}	Volts	
25	6	3.3	0.495
40	6	3.3	0.792
50	6	3.3	0.99

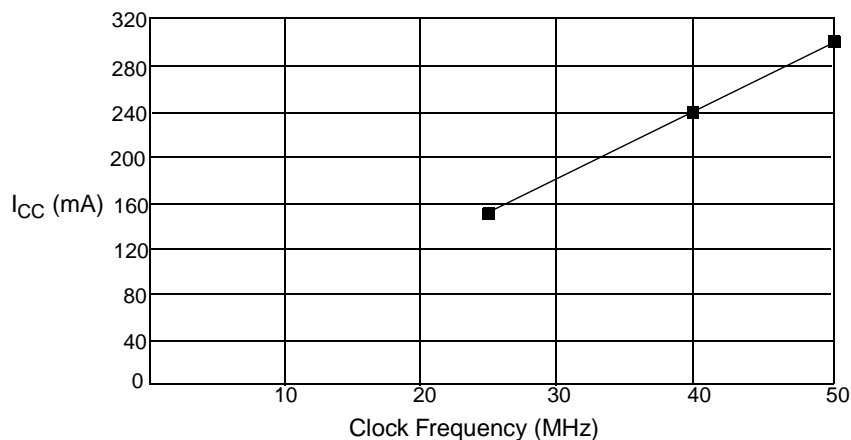

Figure 11. Typical I_{CC} Versus Frequency

THERMAL CHARACTERISTICS—PQFP PACKAGE

The Am186CH HDLC microcontroller is specified for operation with case temperature ranges from 0°C to +100°C for 3.3 V ± 0.3 V (commercial). Case temperature is measured at the top center of the package as shown in Figure 12. The various temperatures and thermal resistances can be determined using the equations in Figure 13 with information given in Table 8.

The total thermal resistance is θ_{JA} ; θ_{JA} is the sum of θ_{JC} , the internal thermal resistance of the assembly, and θ_{CA} , the case-to-ambient thermal resistance.

The variable P is power in watts. Power supply current (I_{CC}) is in mA per MHz of clock frequency.

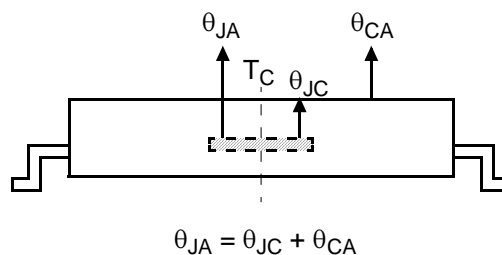

Figure 12. Thermal Resistance(°C/Watt)

$$\begin{aligned} \theta_{JA} &= \theta_{JC} + \theta_{CA} \\ P &= I_{CC} \cdot \text{freq (MHz)} \cdot V_{CC} \\ T_J &= T_C + (P \cdot \theta_{JC}) \\ T_J &= T_A + (P \cdot \theta_{JA}) \\ T_C &= T_J - (P \cdot \theta_{JC}) \\ T_C &= T_A + (P \cdot \theta_{CA}) \\ T_A &= T_J - (P \cdot \theta_{JA}) \\ T_A &= T_C - (P \cdot \theta_{CA}) \end{aligned}$$

Figure 13. Thermal Characteristics Equations

Table 8. Thermal Characteristics (°C/Watt)

Package/Board	Airflow (Linear Feet per Minute)	θ_{JC}	θ_{CA}	θ_{JA}
PQFP/2-Layer	0 fpm	7	38	45
	200 fpm	7	32	39
	400 fpm	7	28	35
	600 fpm	7	26	33
PQFP/4-Layer to 6-Layer	0 fpm	5	18	23
	200 fpm	5	16	21
	400 fpm	5	14	19
	600 fpm	5	12	17

COMMERCIAL AND INDUSTRIAL SWITCHING CHARACTERISTICS AND WAVEFORMS

In the switching waveforms that follow, several abbreviations are used to indicate the specific periods of a bus cycle. These periods are referred to as time states. A typical bus cycle is composed of four consecutive time states: t_1 , t_2 , t_3 , and t_4 . Wait states, which represent multiple t_3 states, are referred to as t_w states. When no bus cycle is pending, an idle (t_i) state occurs.

In the switching parameter descriptions, the *multiplexed* address is referred to as the AD address

bus; the *demultiplexed* address is referred to as the A address bus. Figure 14 defines symbols used in the switching waveform diagrams.

Table 9 on page 41 contains an alphabetical listing of the switching parameter symbols (grouped by function), and Table 10 on page 44 contains a numerical listing of the switching parameter symbols (grouped by function).



WAVEFORM	INPUT	OUTPUT
	Must be Steady	Will be Steady
	May change from H to L or from H to three-state	Will be changing from H to L or from H to three-state
	May change from L to H or from L to three-state	Will be changing from L to H or from L to three-state

Figure 14. Key to Switching Waveforms

Table 9. Alphabetical Key to Switching Parameter Symbols

Parameter Symbol	No.	Description
t_{ARYCH}	49	ARDY resolution transition setup time
t_{ARYCHL}	51	ARDY inactive holding time
t_{ARYHDSH}	95 ¹	ARDY High to $\overline{\text{DS}}$ High
t_{ARYHDV}	89 ¹	ARDY assert to data valid
t_{ARYLCL}	52	ARDY setup time
t_{ARYLDSH}	96 ¹	ARDY Low to $\overline{\text{DS}}$ High
t_{AVBL}	87	A address valid to $\overline{\text{WHB}}$, $\overline{\text{WLB}}$ Low
t_{AVCH}	14	AD address valid to clock High
t_{AVLL}	12	AD address valid to ALE Low
t_{AVRL}	66	A address valid to $\overline{\text{RD}}$ Low
t_{AVWL}	65	A address valid to $\overline{\text{WR}}$ Low
t_{AZRL}	24	AD address float to $\overline{\text{RD}}$ active
t_{CH1CH2}	45	CLKOUT rise time
t_{CHAV}	68	CLKOUT High to A address valid
t_{CHCAS}	404	Change in $\overline{\text{CAS}}$ delay
t_{CHCK}	38	X1 High time
t_{CHCL}	44	CLKOUT High time
t_{CHCSV}	67	CLKOUT High to $\overline{\text{LCS}}/\overline{\text{UCS}}$ valid
t_{CHCSX}	18	$\overline{\text{MCSx}}/\overline{\text{PCSx}}$ inactive delay
t_{CHCTV}	22	Control active delay 2
t_{CHCV}	64	Command lines valid delay (after float)
t_{CHCZ}	63	Command lines float delay
t_{CHDX}	8	Status hold time
t_{CHLH}	9	ALE active delay
t_{CHLL}	11	ALE inactive delay
t_{CHQS0V}	55	Queue status 0 output delay
t_{CHQS1V}	56	Queue status 1 output delay
t_{CHRAS}	403	Change in $\overline{\text{RAS}}$ delay
t_{CHRFD}	79 ¹	CLKOUT High to $\overline{\text{RFSH}}$ valid
t_{CHSV}	3	Status active delay
t_{CICO}	69	X1 to CLKOUT skew
t_{CKHL}	39	X1 fall time
t_{CKIN}	36	X1 period
t_{CKLH}	40	X1 rise time
t_{CL2CL1}	46	CLKOUT fall time
t_{CLARX}	50	ARDY active hold time
t_{CLAV}	5	AD address and $\overline{\text{BHE}}$ valid delay
t_{CLAX}	6	Address hold
t_{CLAZ}	15	AD address float delay
t_{CLCH}	43	CLKOUT Low time
t_{CLCK}	37	X1 Low time
t_{CLCL}	42	CLKOUT period
t_{CLCLX}	80 ¹	$\overline{\text{LCS}}$ inactive delay

Table 9. Alphabetical Key to Switching Parameter Symbols (Continued)

Parameter Symbol	No.	Description
t_{CLCSL}	81 ¹	\overline{LCS} active delay
t_{CLCSV}	16	$\overline{MCSx/PCSx}$ active delay
t_{CLDOX}	30	Data hold time
t_{CLDV}	7	Data valid delay
t_{CLDX}	2	Data in hold
t_{CLHAV}	62	HLDA valid delay
t_{CLRF}	82 ¹	CLKOUT High to \overline{RFSH} invalid
t_{CLRH}	27	\overline{RD} inactive delay
t_{CLRL}	25	\overline{RD} active delay
t_{CLRO}	61	Reset delay
t_{CLSH}	4	Status and \overline{BHE} inactive delay
t_{CLSRV}	48	SRDY transition hold time
t_{CLTMV}	54	Timer output delay
t_{COLV}	402	Column address valid delay
$t_{CSHARYL}$	88 ¹	Chip select to ARDY Low
t_{CVCTV}	20	Control active delay 1
t_{CVCTX}	31	Control inactive delay
t_{CVDEX}	21	$\overline{DEN/DS}$ inactive delay
t_{CXCSX}	17	$\overline{MCSx/PCSx}$ hold from command inactive
t_{DSHDIR}	92 ¹	\overline{DS} High to data invalid—read
t_{DSHDIW}	98 ¹	\overline{DS} High to data invalid—write
t_{DSHDX}	93 ¹	\overline{DS} High to data bus turn-off time
t_{DShLH}	41	\overline{DS} inactive to ALE inactive
t_{DSLDD}	90 ¹	\overline{DS} Low to data driven
t_{DSLdv}	91 ¹	\overline{DS} Low to data valid
t_{DVCL}	1	Data in setup
t_{DVDSL}	97 ¹	Data valid to \overline{DS} Low
t_{DXDL}	19	$\overline{DEN/DS}$ inactive to $\overline{DT/R}$ Low
t_{HVCL}	58	HOLD setup
t_{INVCH}	53	Peripheral setup time
t_{LCRF}	86 ¹	\overline{LCS} inactive to \overline{RFSH} active delay
t_{LHAV}	23	ALE High to address valid
t_{LHLL}	10	ALE width
t_{LLAX}	13	AD address hold from ALE inactive
t_{LRLL}	84 ¹	\overline{LCS} precharge pulse width
t_{RESIN}	57	\overline{RES} setup time
t_{RFCY}	85 ¹	\overline{RFSH} cycle time
t_{RHAV}	29	\overline{RD} inactive to AD address active
t_{RHDX}	59	\overline{RD} High to data hold on AD bus
t_{RHDZ}	94 ¹	\overline{RD} High to data bus turn-off time
t_{RHLH}	28	\overline{RD} inactive to ALE High
t_{RLRH}	26	\overline{RD} pulse width
t_{SRVCL}	47	SRDY transition setup time

Table 9. Alphabetical Key to Switching Parameter Symbols (Continued)

Parameter Symbol	No.	Description
t_{WHDEX}	35	\overline{WR} inactive to \overline{DEN} inactive
t_{WHDX}	34	Data hold after \overline{WR}
t_{WHLH}	33	\overline{WR} inactive to ALE High
t_{WLWH}	32	\overline{WR} pulse width
DCE		
t_{TCLKH}	2	DCE clock High
t_{TCLKHD}	6	DCE clock hold
t_{TCLKL}	3	DCE clock Low
t_{TCLKO}	4	DCE clock to output delay
$t_{TCLKPER}$	1	DCE clock period
t_{TCLKR}	7	DCE clock rise/fall
t_{TCLKSU}	5	DCE clock setup
PCM (Slave)		
t_{CLKP}	1	PCM clock period
t_{DCD}	8	Delay time from CLK High to TXD valid
t_{DCLT}	13	Delay from CLK Low of last bit to \overline{TSC} invalid
t_{DCT}	11	Delay to \overline{TSC} valid from CLK
t_{DFT}	12	Delay to \overline{TSC} valid from FSC
t_{DTW}	17	Delay from last bit CLK Low to TXD weak drive
t_{DZC}	5	Delay time to valid TXD from CLK
t_{DZF}	6	Delay time to valid TXD from FSC
t_{HCD}	10	Hold time from CLK Low to RXD invalid
t_{HCF}	4	Hold time from CLK Low to FSC valid
t_{HFI}	14	Hold time from CLK Low to FSC invalid
t_{SUDC}	9	Setup time from RXD valid to CLK
t_{SUFC}	7	Setup time for FSC High to CLK Low
t_{SYNSS}	15	Time between successive synchronization pulses
t_{WH}	2	PCM clock High
t_{WL}	3	PCM clock Low
t_{WSYN}	16	FSC width invalid
t_{DTZ}	18	Delay from last bit CLK (plus one) High to TXD disable
PCM (Master)		
t_{DCFH}	1	Delay time from CLK High to FSC High
t_{DCFL}	2	Delay time from CLK High to FSC Low
SSI		
t_{CLEV}	1	CLKOUT Low to SDEN valid
t_{CLSL}	2	CLKOUT Low to SCLK Low
t_{DVSH}	3	Data valid to SCLK High
t_{SHDX}	4	SCLK High to data invalid
t_{SLDV}	5	SCLK Low to data valid

Notes:

1. Specification defined but not in use at this time.

Table 10. Numerical Key to Switching Parameter Symbols

No.	Parameter Symbol	Description
1	t_{DVCL}	Data in setup
2	t_{CLDX}	Data in hold
3	t_{CHSV}	Status active delay
4	t_{CLSH}	Status and \overline{BHE} inactive delay
5	t_{CLAV}	AD address and \overline{BHE} valid delay
6	t_{CLAX}	Address hold
7	t_{CLDV}	Data valid delay
8	t_{CHDX}	Status hold time
9	t_{CHLH}	ALE active delay
10	t_{LHLL}	ALE width
11	t_{CHLL}	ALE inactive delay
12	t_{AVLL}	AD address valid to ALE Low
13	t_{LLAX}	AD address hold from ALE inactive
14	t_{AVCH}	AD address valid to clock High
15	t_{CLAZ}	AD address float delay
16	t_{CLCSV}	$\overline{MCSx/PCSx}$ active delay
17	t_{CXCSX}	$\overline{MCSx/PCSx}$ hold from command inactive
18	t_{CHCSX}	$\overline{MCSx/PCSx}$ inactive delay
19	t_{DXDL}	$\overline{DEN/DS}$ inactive to $\overline{DT/R}$ Low
20	t_{CVCTV}	Control active delay 1
21	t_{CVDEX}	$\overline{DEN/DS}$ inactive delay
22	t_{CHCTV}	Control active delay 2
23	t_{LHAV}	ALE High to address valid
24	t_{AZRL}	AD address float to \overline{RD} active
25	t_{CLRL}	\overline{RD} active delay
26	t_{RLRH}	\overline{RD} pulse width
27	t_{CLRH}	\overline{RD} inactive delay
28	t_{RHLH}	\overline{RD} inactive to ALE High
29	t_{RHAV}	\overline{RD} inactive to AD address active
30	t_{CLDOX}	Data hold time
31	t_{CVCTX}	Control inactive delay
32	t_{WLWH}	\overline{WR} pulse width
33	t_{WHLH}	\overline{WR} inactive to ALE High
34	t_{WHDX}	Data hold after \overline{WR}
35	t_{WHDEX}	\overline{WR} inactive to \overline{DEN} inactive
36	t_{CKIN}	X1 period
37	t_{CLCK}	X1 Low time
38	t_{CHCK}	X1 High time
39	t_{CKHL}	X1 fall time
40	t_{CKLH}	X1 rise time
41	t_{DShLH}	\overline{DS} inactive to ALE inactive
42	t_{CLCL}	CLKOUT period
43	t_{CLCH}	CLKOUT Low time

Table 10. Numerical Key to Switching Parameter Symbols (Continued)

No.	Parameter Symbol	Description
44	t_{CHCL}	CLKOUT High time
45	t_{CH1CH2}	CLKOUT rise time
46	t_{CL2CL1}	CLKOUT fall time
47	t_{SRYCL}	SRDY transition setup time
48	t_{CLSR}	SRDY transition hold time
49	t_{ARYCH}	ARDY resolution transition setup time
50	t_{CLARX}	ARDY active hold time
51	t_{ARYCHL}	ARDY inactive holding time
52	t_{ARYLCL}	ARDY setup time
53	t_{INVCH}	Peripheral setup time
54	t_{CLTMV}	Timer output delay
55	t_{CHQS0V}	Queue status 0 output delay
56	t_{CHQS1V}	Queue status 1 output delay
57	t_{RESIN}	\overline{RES} setup time
58	t_{HVCL}	HOLD setup
59	t_{RHDX}	\overline{RD} High to data hold on AD bus
61	t_{CLRO}	Reset delay
62	t_{CLHAV}	HLDA valid delay
63	t_{CHCZ}	Command lines float delay
64	t_{CHCV}	Command lines valid delay (after float)
65	t_{AVWL}	A address valid to \overline{WR} Low
66	t_{AVRL}	A address valid to \overline{RD} Low
67	t_{CHCSV}	CLKOUT High to $\overline{LCS}/\overline{UCS}$ valid
68	t_{CHAV}	CLKOUT High to A address valid
69	t_{CICO}	X1 to CLKOUT skew
79 ¹	t_{CHRFD}	CLKOUT High to \overline{RFSH} valid
80 ¹	t_{CLCLX}	\overline{LCS} inactive delay
81 ¹	t_{CLCSL}	\overline{LCS} active delay
82 ¹	t_{CLRF}	CLKOUT High to \overline{RFSH} invalid
84 ¹	t_{LRLL}	\overline{LCS} precharge pulse width
85 ¹	t_{RFCY}	\overline{RFSH} cycle time
86 ¹	t_{LCRF}	\overline{LCS} inactive to \overline{RFSH} active delay
87	t_{AVBL}	A address valid to \overline{WHB} , \overline{WLB} Low
88 ¹	$t_{CSHARYL}$	Chip select to ARDY Low
89 ¹	t_{ARYHDV}	ARDY assert to data valid
90 ¹	t_{DSLDD}	\overline{DS} Low to data driven
91 ¹	$t_{DSL DV}$	\overline{DS} Low to data valid
92 ¹	t_{DSHDIR}	\overline{DS} High to data invalid—read
93 ¹	t_{DSHDX}	\overline{DS} High to data bus turn-off time
94 ¹	t_{RHDZ}	\overline{RD} High to data bus turn-off time
95 ¹	$t_{ARYHDSH}$	ARDY High to \overline{DS} High
96 ¹	$t_{ARYLDSH}$	ARDY Low to \overline{DS} High
97 ¹	t_{DVDSL}	Data valid to \overline{DS} Low

Table 10. Numerical Key to Switching Parameter Symbols (Continued)

No.	Parameter Symbol	Description
98 ¹	t_{DSHDIW}	$\overline{\text{DS}}$ High to data invalid—write
402	t_{COLV}	Column address valid delay
403	t_{CHRAS}	Change in $\overline{\text{RAS}}$ delay
404	t_{CHCAS}	Change in $\overline{\text{CAS}}$ delay
DCE		
1	t_{TCLKPER}	DCE clock period
2	t_{TCLKH}	DCE clock High
3	t_{TCLKL}	DCE clock Low
4	t_{TCLKO}	DCE clock to output delay
5	t_{TCLKSU}	DCE clock setup
6	t_{TCLKHD}	DCE clock hold
7	t_{TCLKR}	DCE clock rise/fall
PCM (Slave)		
1	t_{CLKP}	PCM clock period
2	t_{WH}	PCM clock High
3	t_{WL}	PCM clock Low
4	t_{HCF}	Hold time from CLK Low to FSC valid
5	t_{DZC}	Delay time to valid TXD from CLK
6	t_{DZF}	Delay time to valid TXD from FSC
7	t_{SUFC}	Setup time for FSC High to CLK Low
8	t_{DCD}	Delay time from CLK High to TXD valid
9	t_{SUDC}	Setup time from RXD valid to CLK
10	t_{HCD}	Hold time from CLK Low to RXD invalid
11	t_{DCT}	Delay to $\overline{\text{TSC}}$ valid from CLK
12	t_{DFT}	Delay to $\overline{\text{TSC}}$ valid from FSC
13	t_{DCLT}	Delay from CLK Low of last bit to $\overline{\text{TSC}}$ invalid
14	t_{HFI}	Hold time from CLK Low to FSC invalid
15	t_{SYNSS}	Time between successive synchronization pulses
16	t_{WSYN}	FSC width invalid
17	t_{DTW}	Delay from last bit CLK Low to TXD weak drive
18	t_{DTZ}	Delay from last bit CLK (plus one) High to TXD disable
PCM (Master)		
t_{DCFH}	1	Delay time from CLK High to FSC High
t_{DCFL}	2	Delay time from CLK High to FSC Low
SSI		
1	t_{CLEV}	CLKOUT Low to SDEN valid
2	t_{CLSL}	CLKOUT Low to SCLK Low
3	t_{DVSH}	Data valid to SCLK High
4	t_{SHDX}	SCLK High to data invalid
5	t_{SLDV}	SCLK Low to data valid

Notes:

1. Specification defined but not in use at this time.

Switching Characteristics over Commercial and Industrial Operating Ranges

In this section, the following timings and timing waveforms are shown:

- Read (page 47)
- Write (page 50)
- Software halt (page 53)
- Peripheral (page 54)
- Reset (page 55)
- External ready (page 57)
- Bus hold (page 59)
- System clocks (page 61)
- PCM highway (slave) (page 62)
- DCE interface (page 65)
- SSI (page 66)
- DRAM (page 67)

Table 11. Read Cycle Timing¹

Parameter			Preliminary						Unit
			25 MHz		40 MHz		50 MHz (Commercial Only)		
No.	Symbol	Description	Min	Max	Min	Max	Min	Max	
General Timing Requirements									
1	t _{DVCL}	Data in setup	10	—	5	—	5	—	ns
2	t _{CLDX}	Data in hold ²	3	—	2	—	2	—	ns
General Timing Responses									
3	t _{CHSV}	Status active delay	0	20	0	12	0	10	ns
4	t _{CLSH}	Status and $\overline{\text{BHE}}$ inactive delay	0	20	0	12	0	10	ns
5	t _{CLAV}	AD address and $\overline{\text{BHE}}$ valid delay	0	20	0	12	0	10	ns
6	t _{CLAX}	Address hold	0	—	0	—	0	—	ns
8	t _{CHDX}	Status hold time	0	—	0	—	0	—	ns
9	t _{CHLH}	ALE active delay	—	20	—	12	—	10	ns
10	t _{LHLL}	ALE width	t _{CLCL} -10=30	—	t _{CLCL} -5=20	—	t _{CLCL} -5=15	—	ns
11	t _{CHLL}	ALE inactive delay	—	20	—	12	—	10	ns
12	t _{AVLL}	AD address valid to ALE Low ³	0.5 • t _{CLCH}	—	0.5 • t _{CLCH}	—	0.5 • t _{CLCH}	—	ns
13	t _{LLAX}	AD address hold from ALE inactive ³	t _{CHCL}	—	t _{CHCL}	—	t _{CHCL}	—	ns
14	t _{AVCH}	AD address valid to clock High	0	—	0	—	0	—	ns
15	t _{CLAZ}	AD address float delay	t _{CLAX} =0	20	t _{CLAX} =0	12	t _{CLAX} =0	10	ns
16	t _{CLCSV}	$\overline{\text{MCSx/PCSx}}$ active delay	0	20	0	12	0	10	ns
17	t _{CXCSX}	$\overline{\text{MCSx/PCSx}}$ hold from command inactive	t _{CLCH}	—	t _{CLCH}	—	t _{CLCH}	—	ns
18	t _{CHCSX}	$\overline{\text{MCSx/PCSx}}$ inactive delay	0	20	0	12	0	10	ns
19	t _{DXDL}	$\overline{\text{DEN/DS}}$ inactive to DT/ $\overline{\text{R}}$ Low ^{3, 4}	-1	—	-1	—	-1	—	ns
20	t _{CVCTV}	Control active delay 1	0	20	0	12	0	10	ns

Table 11. Read Cycle Timing¹ (Continued)

Parameter			Preliminary						Unit
			25 MHz		40 MHz		50 MHz (Commercial Only)		
No.	Symbol	Description	Min	Max	Min	Max	Min	Max	
21	t _{CVDEX}	$\overline{DEN}/\overline{DS}$ inactive delay ⁴	0	20	0	12	0	10	ns
22	t _{CHCTV}	Control active delay 2	0	20	0	12	0	10	ns
23	t _{LHAV}	ALE High to address valid	15	—	7.5	—	5	—	ns
Read Cycle Timing Responses									
24	t _{AZRL}	AD address float to \overline{RD} active	0	—	0	—	0	—	ns
25	t _{CLRL}	\overline{RD} active delay	0	20	0	10	0	10	ns
26	t _{RLRH}	\overline{RD} pulse width	2t _{CLCL} -15=65	—	2t _{CLCL} -10=40	—	2t _{CLCL} -10=30	—	ns
27	t _{CLR_H}	\overline{RD} inactive delay	0	20	0	12	0	10	ns
28	t _{RHLH}	\overline{RD} inactive to ALE High ³	t _{CLCH} -3	—	t _{CLCH} -2	—	t _{CLCH} -2	—	ns
29	t _{RHAV}	\overline{RD} inactive to AD address active ³	t _{CLCL} -10=30	—	t _{CLCL} -5=20	—	t _{CLCL} -5=15	—	ns
59	t _{RHDX}	\overline{RD} High to data hold on AD Bus ²	3	—	2	—	0	—	ns
66	t _{AVRL}	A address valid to \overline{RD} Low	1.5t _{CLCL} -15=45	—	1.5t _{CLCL} -10=27.5	—	1.5t _{CLCL} -10=20	—	ns
67	t _{CHCSV}	CLKOUT High to LCS/UCS valid	0	20	0	10	0	10	ns
68	t _{CHAV}	CLKOUT High to A address valid	0	20	0	10	0	10	ns

Notes:

1. All timing parameters are measured at V_{CC}/2 with 50-pF loading on CLKOUT unless otherwise noted. All output test conditions are with the load values shown in Table 30, "Pin List Summary," on page A-11.
2. If either specification 2 or specification 59 is met with respect to data hold time, then the device functions correctly.
3. Testing is performed with equal loading on referenced pins.
4. The timing of this signal is the same for a read cycle, whether it is configured to be \overline{DEN} or \overline{DS} .

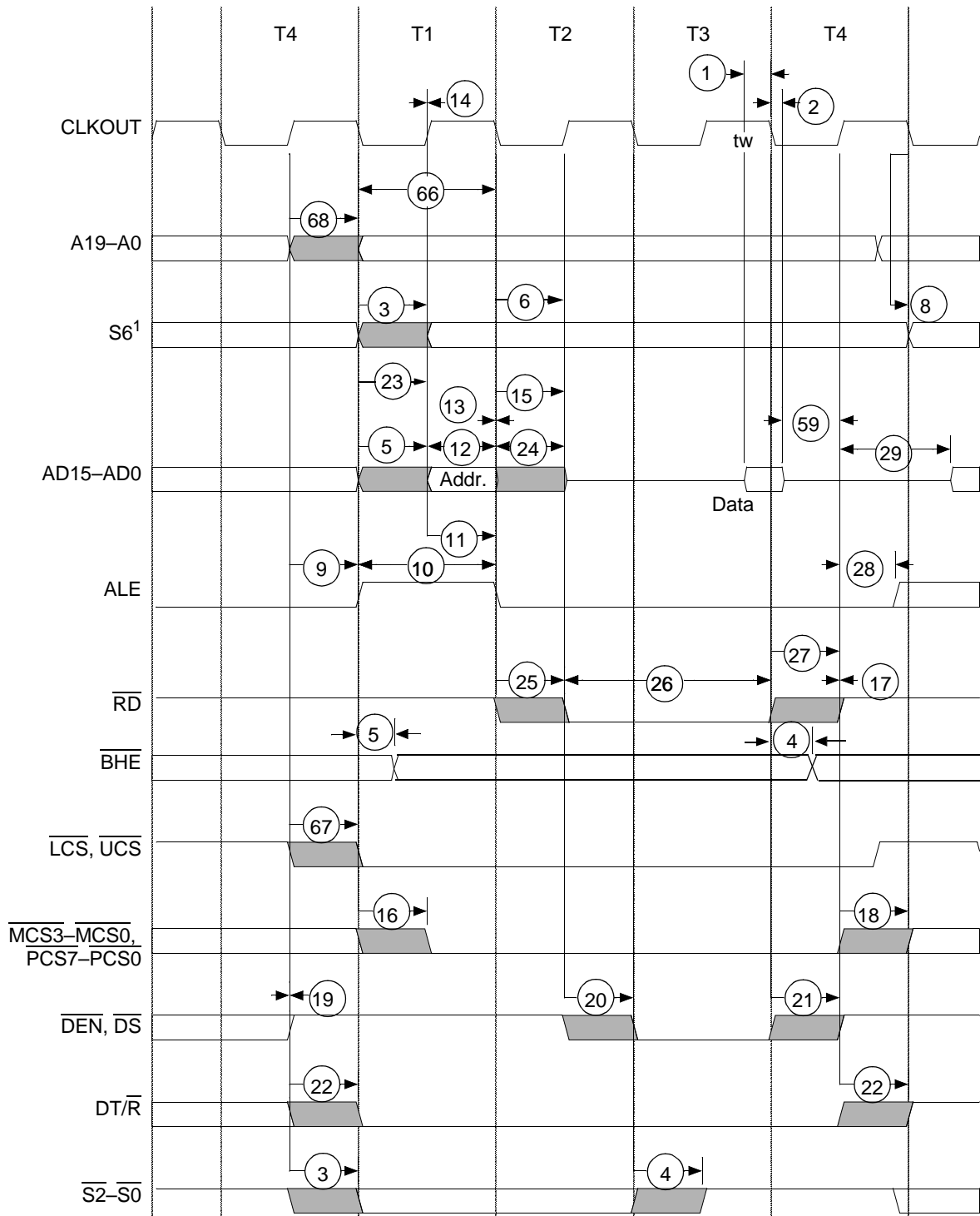

Notes:

1. $S6$ is not valid for the first fetch until the timing for parameter 3 (status active delay (t_{CHSV})) is met.

Figure 15. Read Cycle Waveforms

Table 12. Write Cycle Timing¹

Parameter			Preliminary						Unit
			25 MHz		40 MHz		50 MHz (Commercial Only)		
No.	Symbol	Description	Min	Max	Min	Max	Min	Max	
General Timing Responses									
3	t_{CHSV}	Status active delay	0	20	0	12	0	10	ns
4	t_{CLSH}	Status and \overline{BHE} inactive delay	0	20	0	12	0	10	ns
5	t_{CLAV}	AD address and \overline{BHE} valid delay	0	20	0	12	0	10	ns
6	t_{CLAX}	Address hold	0	—	0	—	0	—	ns
7	t_{CLDV}	Data valid delay	0	20	0	12	0	10	ns
8	t_{CHDX}	Status hold time	0	—	0	—	0	—	ns
9	t_{CHLH}	ALE active delay	—	20	—	12	—	10	ns
10	t_{LHLL}	ALE width	$t_{CLCL} - 10 = 30$	—	$t_{CLCL} - 5 = 20$	—	$t_{CLCL} - 5 = 15$	—	ns
11	t_{CHLL}	ALE inactive delay	—	20	—	12	—	10	ns
12	t_{AVLL}	AD address valid to ALE Low ²	$0.5 \cdot t_{CLCH}$	—	$0.5 \cdot t_{CLCH}$	—	$0.5 \cdot t_{CLCH}$	—	ns
13	t_{LLAX}	AD address hold from ALE inactive	t_{CHCL}	—	t_{CHCL}	—	t_{CHCL}	—	ns
14	t_{AVCH}	AD address valid to clock High	0	—	0	—	0	—	ns
16	t_{CLCSV}	$\overline{MCSx/PCSx}$ active delay	0	20	0	12	0	10	ns
17	t_{CXCSX}	$\overline{MCSx/PCSx}$ hold from command inactive	t_{CLCH}	—	t_{CLCH}	—	t_{CLCH}	—	ns
18	t_{CHCSX}	$\overline{MCSx/PCSx}$ inactive delay	0	20	0	12	0	10	ns
19	t_{DXDL}	\overline{DEN} inactive to $\overline{DT/R}^{2,3}$	-1	—	-1	—	-1	—	ns
20	t_{CVCTV}	Control active delay ^{3,4}	0	20	0	12	0	10	ns
21	t_{CVDEX}	DS inactive delay ^{3,4}	0	20	0	12	0	10	ns
23	t_{LHAV}	ALE High to address valid	15	—	7.5	—	5	—	ns

Table 12. Write Cycle Timing¹ (Continued)

Parameter			Preliminary						Unit
			25 MHz		40 MHz		50 MHz (Commercial Only)		
No.	Symbol	Description	Min	Max	Min	Max	Min	Max	
Write Cycle Timing Responses									
30	t_{CLDOX}	Data hold time	0	—	0	—	0	—	ns
31	t_{CVCTX}	Control inactive delay ^{3,4}	0	20	0	12	0	10	ns
32	t_{WLWH}	\overline{WR} pulse width	$2t_{CLCL} - 10 = 70$	—	$2t_{CLCL} - 10 = 40$	—	$2t_{CLCL} - 10 = 30$	—	ns
33	t_{WHLH}	\overline{WR} inactive to ALE High ²	$t_{CLCH} - 2$	—	$t_{CLCH} - 2$	—	$t_{CLCH} - 2$	—	ns
34	t_{WHDX}	Data hold after \overline{WR} ²	$t_{CLCL} - 10 = 30$	—	$t_{CLCL} - 10 = 15$	—	$t_{CLCL} - 10 = 10$	—	ns
35	t_{WHDEX}	\overline{WR} inactive to \overline{DEN} inactive ^{2,3}	$t_{CLCH} - 3$	—	t_{CLCH}	—	t_{CLCH}	—	ns
65	t_{AVWL}	A address valid to \overline{WR} Low	$t_{CLCL} + t_{CHCL} - 3$	—	$t_{CLCL} + t_{CHCL} - 1.25$	—	$t_{CLCL} + t_{CHCL} - 1.25$	—	ns
67	t_{CHCSV}	CLKOUT High to $\overline{LCS}/\overline{UCS}$ valid	0	20	0	10	0	10	ns
68	t_{CHAV}	CLKOUT High to A address valid	0	20	0	10	0	10	ns
87	t_{AVBL}	A address valid to \overline{WHB} , \overline{WLB} Low	$t_{CHCL} - 3$	20	$t_{CHCL} - 1.25$	12	$t_{CHCL} - 1.25$	10	ns

Notes:

1. All timing parameters are measured at $V_{CC}/2$ with 50-pF loading on CLKOUT unless otherwise noted. All output test conditions are with the load values shown in Table 30, "Pin List Summary," on page A-11.
2. Testing is performed with equal loading on referenced pins.
3. The timing of this signal is different during a write cycle depending on whether it is configured to be \overline{DEN} or \overline{DS} .
4. This parameter applies to the \overline{DEN} , \overline{DS} , \overline{WR} , \overline{WHB} , and \overline{WLB} signals.

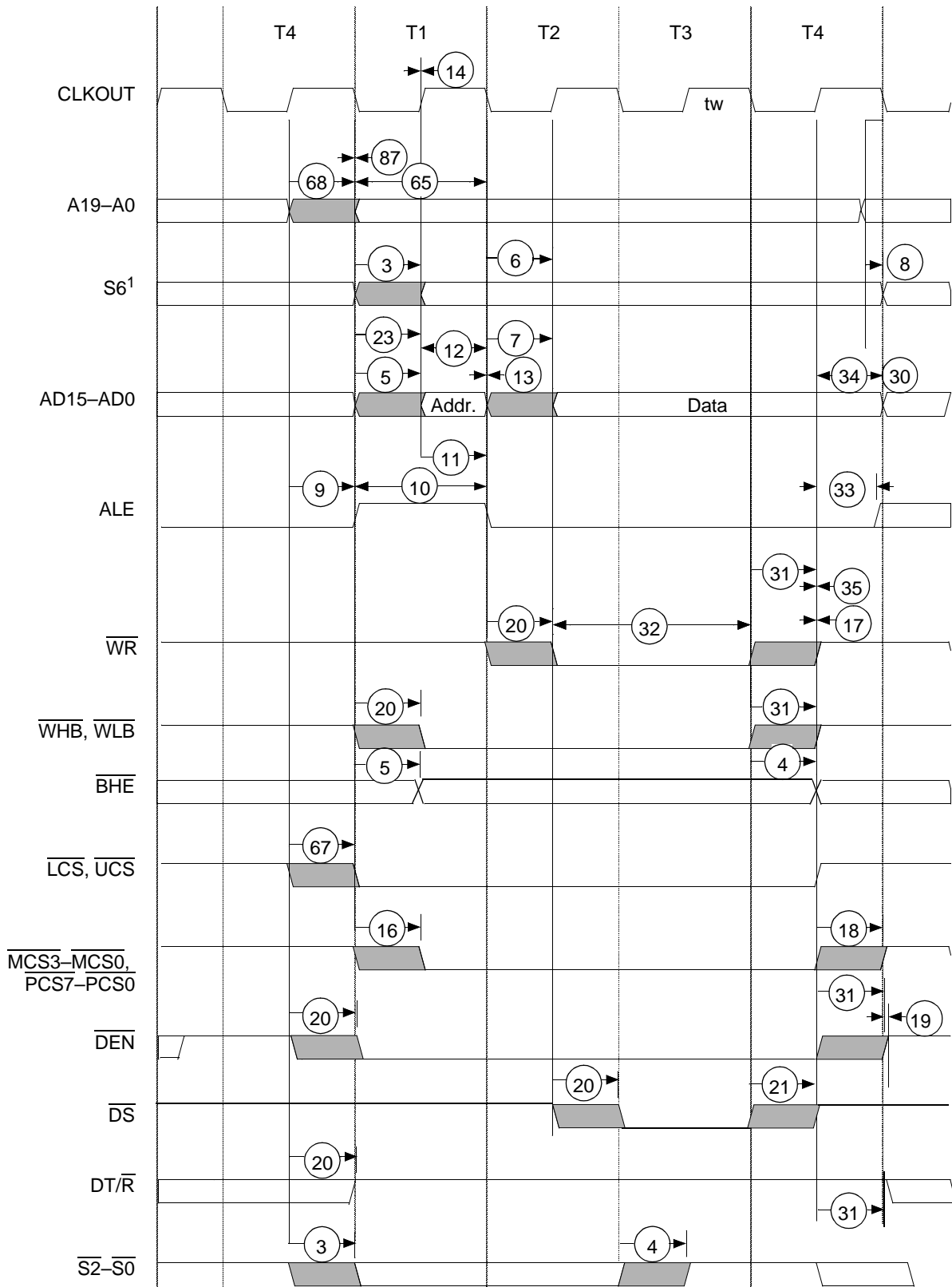

Notes:

1. S6 is not valid for the first fetch until the timing for parameter 3 (status active delay (t_{CHSV})) is met.

Figure 16. Write Cycle Waveforms

Table 13. Software Halt Cycle Timing¹

Parameter			Preliminary						Unit
			25 MHz		40 MHz		50 MHz (Commercial Only)		
No.	Symbol	Description	Min	Max	Min	Max	Min	Max	
3	t _{CHSV}	Status active delay	0	20	0	12	0	10	ns
4	t _{CLSH}	Status inactive delay	0	20	0	12	0	10	ns
5	t _{CLAV}	AD address invalid delay	0	20	0	12	0	10	ns
9	t _{CHLH}	ALE active delay	—	20	—	12	—	10	ns
10	t _{LHLL}	ALE width	t _{CLCL} - 10 = 30	—	t _{CLCL} - 5 = 20	—	t _{CLCL} - 5 = 15	—	ns
11	t _{CHLL}	ALE inactive delay	—	20	—	12	—	10	ns
19	t _{DXDL}	\overline{DEN} inactive to DT/R Low ²	-1	—	-1	—	-1		ns
22	t _{CHCTV}	Control active delay 2 ³	0	20	0	12	0	10	ns
68	t _{CHAV}	CLKOUT High to A address invalid	0	20	0	12	0	10	ns

Notes:

1. All timing parameters are measured at V_{CC}/2 with 50-pF loading on CLKOUT unless otherwise noted. All output test conditions are with the load values shown in Table 30, "Pin List Summary," on page A-11.
2. Testing is performed with equal loading on referenced pins.
3. This parameter applies to the $\overline{DEN}/\overline{DS}$ signal.

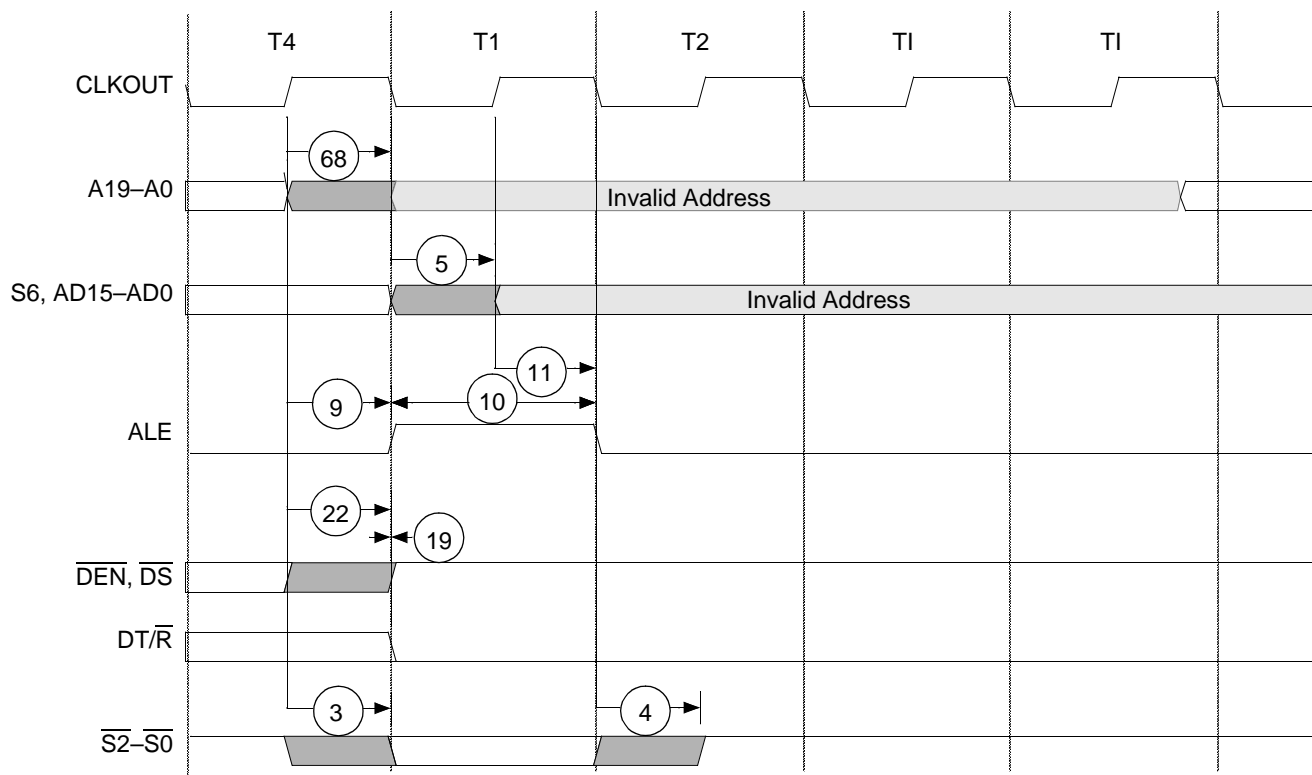

Figure 17. Software Halt Cycle Waveforms

Table 14. Peripheral Timing^{1, 2}

Parameter			Preliminary						Unit
			25 MHz		40 MHz		50 MHz (Commercial Only)		
No.	Symbol	Description	Min	Max	Min	Max	Min	Max	
53	t _{INVCH}	Peripheral setup time	10	—	5	—	5	—	ns
54	t _{CLTMV}	Timer output delay	—	25	—	15	—	12	ns
55	t _{CHQS0V}	Queue status 0 output delay	—	25	—	15	—	12	ns
56	t _{CHQS1V}	Queue status 1 output delay	—	25	—	15	—	12	ns

Notes:

1. All timing parameters are measured at V_{CC}/2 with 50-pF loading on CLKOUT unless otherwise noted. All output test conditions are with the load values shown in Table 30, "Pin List Summary," on page A-11.
2. PIO outputs change anywhere from the beginning of T3 to the first half of T4 of the bus cycle in which the PIO data register is written.

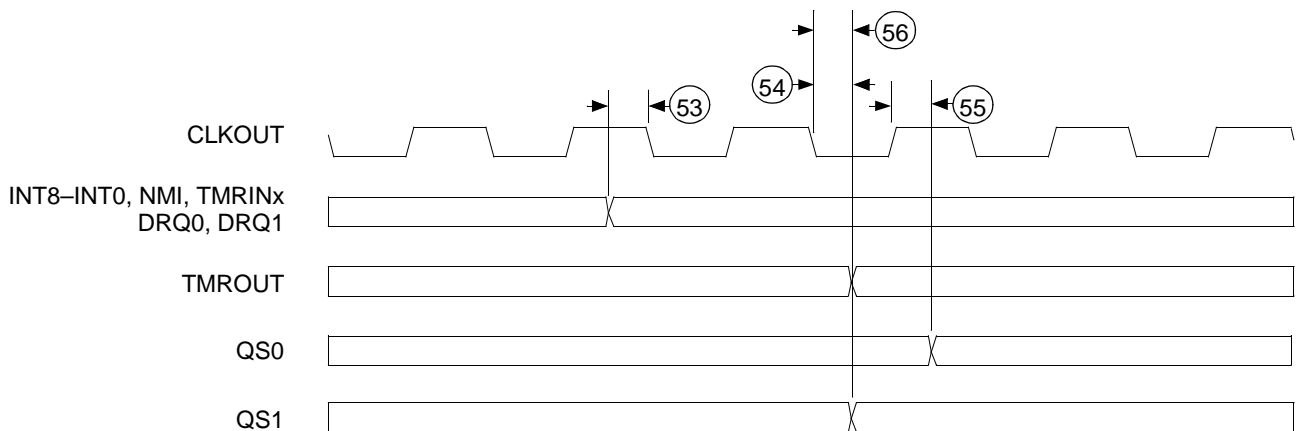

Figure 18. Peripheral Timing Waveforms

Table 15. Reset Timing¹

Parameter			Preliminary						Unit
			25 MHz		40 MHz		50 MHz (Commercial Only)		
No.	Symbol	Description	Min	Max	Min	Max	Min	Max	
57	t_{RESIN}	\overline{RES} setup time	10	—	5	—	5	—	ns
61	t_{CLRO}	Reset delay	—	18	—	15	—	12	ns

Notes:

1. All timing parameters are measured at $V_{CC}/2$ with 50-pF loading on CLKOUT unless otherwise noted. All output test conditions are with the load values shown in Table 30, "Pin List Summary," on page A-11.

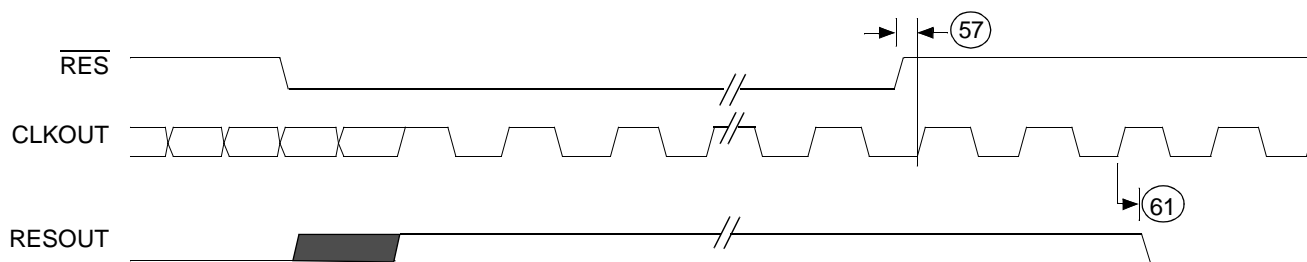
**Notes:**

- \overline{RES} must be held Low for 1 ms during power-up to ensure proper device initialization.
- Diagram is shown for the system PLL in its 2x mode of operation.
- Diagram assumes that V_{CC} is stable (i.e., $3.3\text{ V} \pm 0.3\text{ V}$) during the 1-ms \overline{RES} active time.

Figure 19. Reset Waveforms

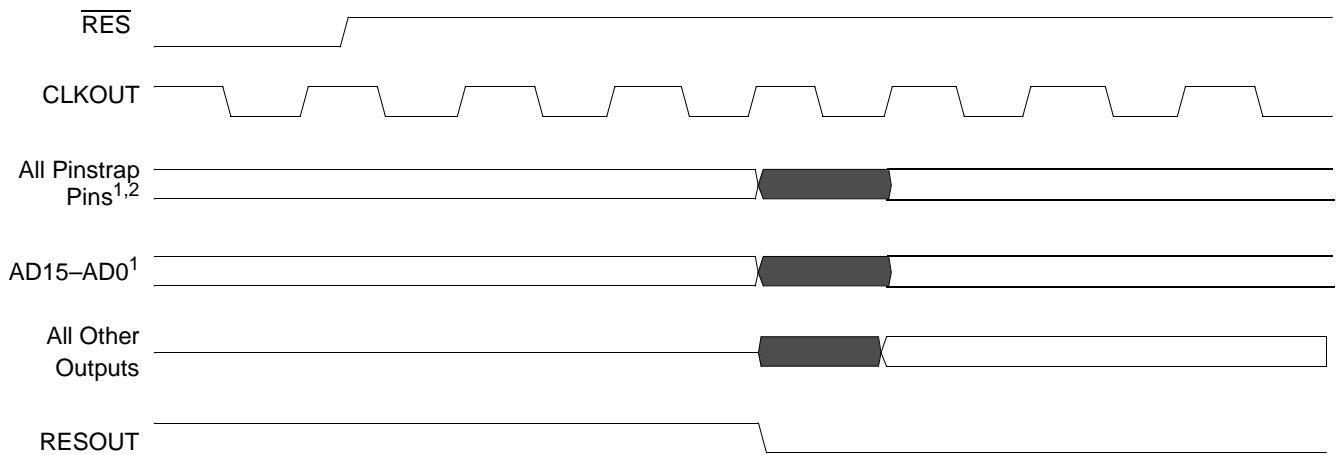

Notes:

1. The pinstraps and AD bus are sampled during the assertion of RESOUT for system configuration purposes.
2. See Appendix A, "Reset Configuration Pins (Pinstraps)," on page A-7 for a list of all the pinstraps.

Figure 20. Signals Related to Reset (System PLL in 1x or 2x Mode)

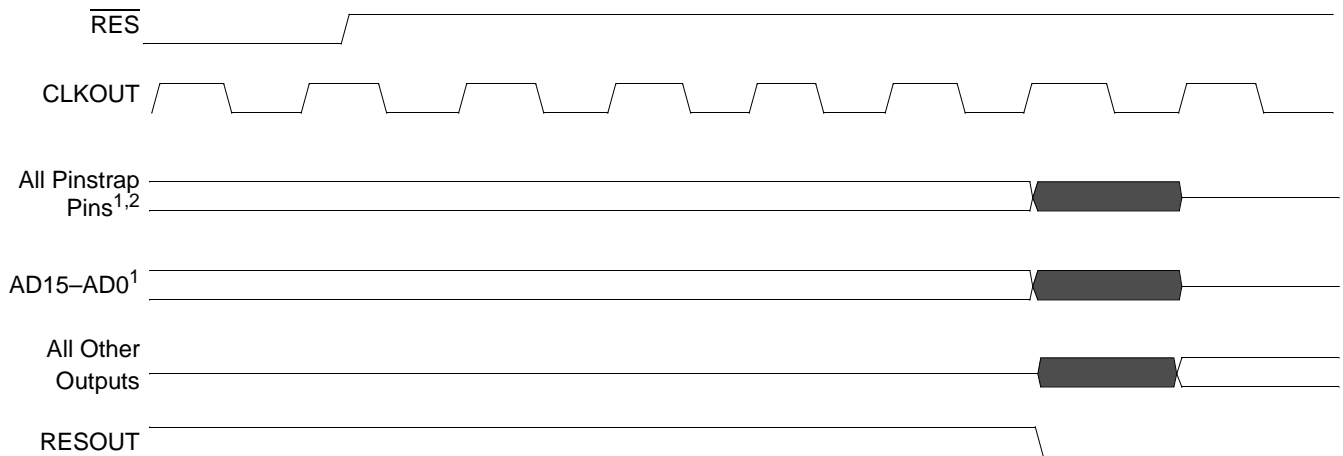

Notes:

1. The pinstraps and AD bus are sampled during the assertion of RESOUT for system configuration purposes.
2. See Appendix A, "Reset Configuration Pins (Pinstraps)," on page A-7 for a list of all the pinstraps.

Figure 21. Signals Related to Reset (System PLL in 4x Mode)

Table 16. External Ready Cycle Timing¹

Parameter			Preliminary						Unit
			25 MHz		40 MHz		50 MHz (Commercial Only)		
No.	Symbol	Description	Min	Max	Min	Max	Min	Max	
Ready Timing Requirements									
47	t _{SRVCL}	SRDY transition setup time ²	10	—	5	—	5	—	ns
48	t _{CLSRV}	SRDY transition hold time ²	3	—	2	—	2	—	ns
49	t _{ARYCH}	ARDY resolution transition setup time ³	10	—	5	—	5	—	ns
50	t _{CLARX}	ARDY active hold time ²	4	—	3	—	3	—	ns
51	t _{ARYCHL}	ARDY inactive holding time	10	—	5	—	5	—	ns
52	t _{ARYLCL}	ARDY setup time ²	15	—	5	—	5	—	ns

Notes:

1. All timing parameters are measured at V_{CC}/2 with 50-pF loading on CLKOUT unless otherwise noted. All output test conditions are with the load values shown in Table 30, "Pin List Summary," on page A-11.
2. This timing must be met to guarantee proper operation.
3. This timing must be met to guarantee recognition at the clock edge.

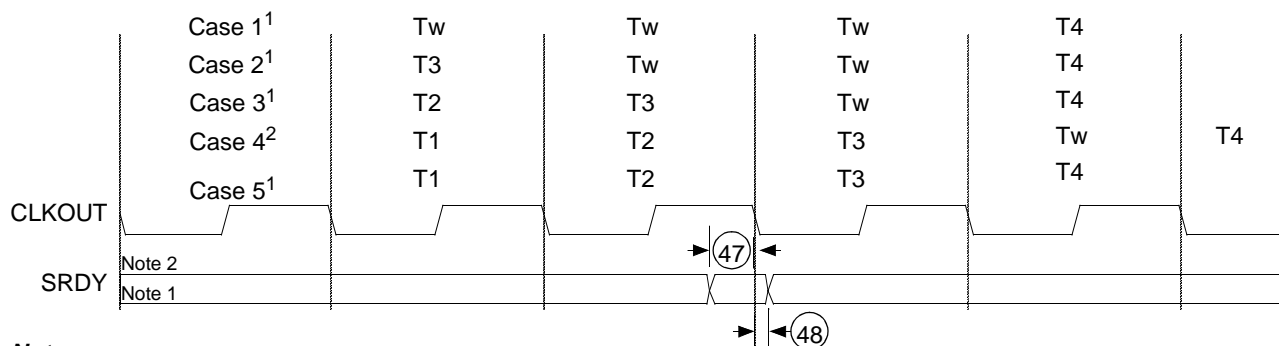

Notes:

1. Normally not ready system
2. Normally ready system

Figure 22. Synchronous Ready Waveforms

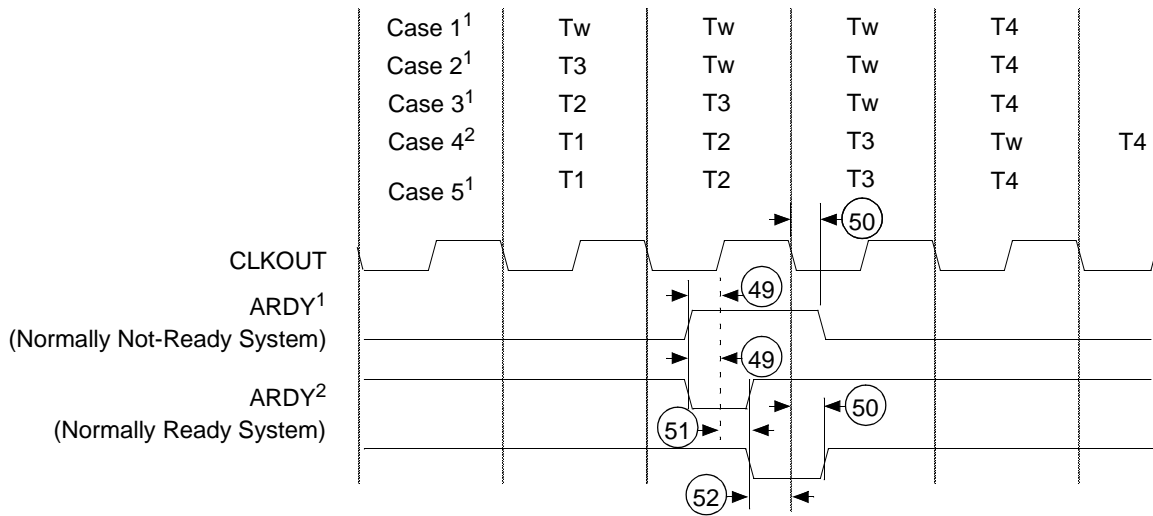

Notes:

1. In a normally not ready system, wait states are added after T3 until t_{ARYCH} (49) and t_{CLARX} (50) are met.
2. In a normally ready system, a wait state is added if t_{ARYCH} (49) and t_{ARYCHL} (51) during T2 or t_{ARYLCL} (52) and t_{CLARX} (50) during T3 are met.

Figure 23. Asynchronous Ready Waveforms

Table 17. Bus Hold Timing¹

Parameter			Preliminary						Unit
			25 MHz		40 MHz		50 MHz (Commercial Only)		
No.	Symbol	Description	Min	Max	Min	Max	Min	Max	
5	t _{CLAV}	AD address valid delay	0	20	0	12	0	10	ns
15	t _{CLAZ}	AD address float delay	0	20	0	12	0	10	ns
18	t _{CHCSX}	MCSx/PCSx inactive delay	0	20	0	12	0	10	ns
58	t _{HVCL}	HOLD setup ²	10	—	5	—	5	—	ns
62	t _{CLHAV}	HLDA valid delay	0	20	0	12	0	10	ns
63	t _{CHCZ}	Command lines float delay	—	20	—	12	—	10	ns
64	t _{CHCV}	Command lines valid delay (after float)	—	25	—	12	—	10	ns

Notes:

1. All timing parameters are measured at V_{CC}/2 with 50-pF loading on CLKOUT unless otherwise noted. All output test conditions are with the load values shown in Table 30, "Pin List Summary," on page A-11.
2. This timing must be met to guarantee recognition at the next clock.

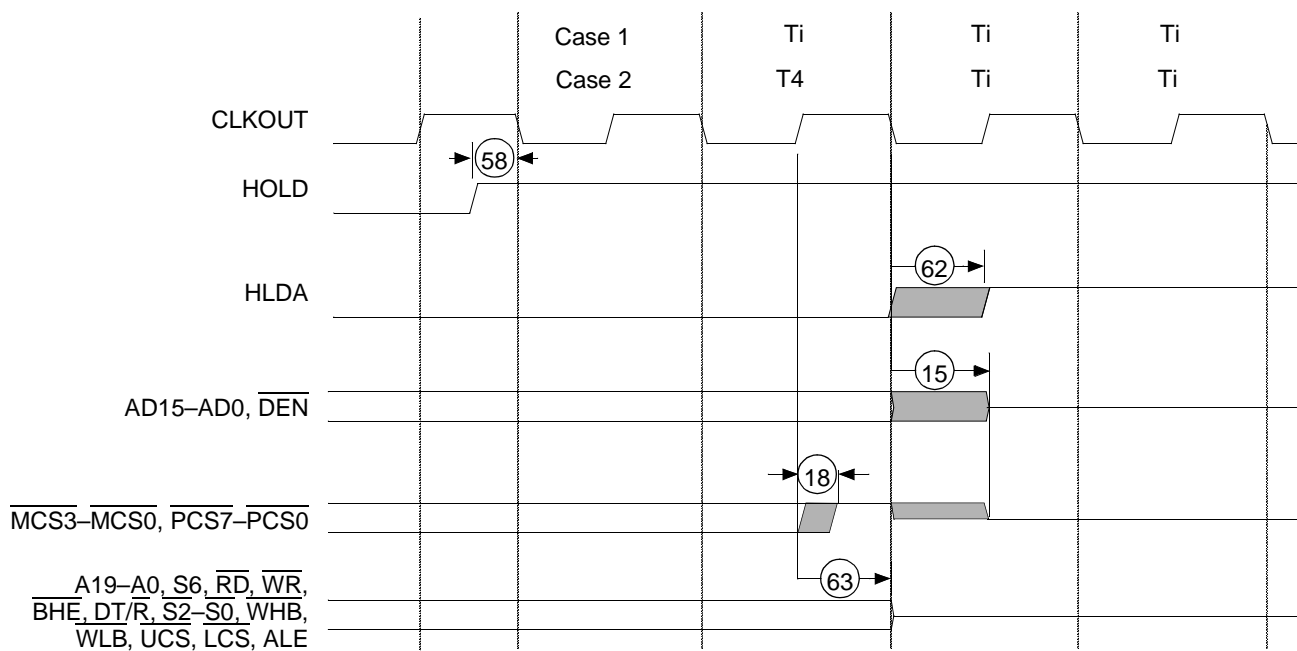

Figure 24. Entering Bus Hold Waveforms

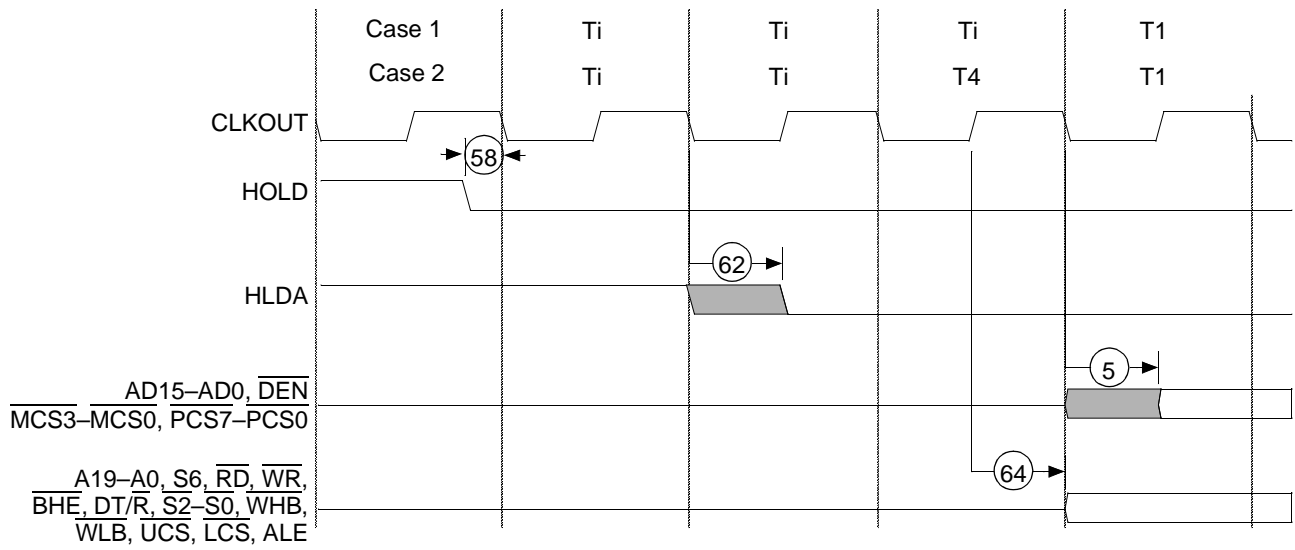

Figure 25. Exiting Bus Hold Waveforms

Table 18. System Clocks Timing¹

Parameter			Preliminary						Unit
			25 MHz		40 MHz		50 MHz (Commercial Only)		
No.	Symbol	Description	Min	Max	Min	Max	Min	Max	
CLKIN Requirements for 4x PLL Mode									
36	t _{CKIN}	X1 period ²	Not Supported		100	125	80	125	ns
37	t _{CLCK}	X1 Low time (1.5 V)			45	—	35	—	ns
38	t _{CHCK}	X1 High time (1.5 V)			45	—	35	—	ns
39	t _{CKHL}	X1 fall time (3.5 to 1.0 V)			—	5	—	5	ns
40	t _{CKLH}	X1 rise time (1.0 to 3.5 V)			—	5	—	5	ns
CLKIN Requirements for 2x PLL Mode									
36	t _{CKIN}	X1 period ²	80	125	50	125	40	125	ns
37	t _{CLCK}	X1 Low time (1.5 V)	35	—	20	—	15	—	ns
38	t _{CHCK}	X1 High time (1.5 V)	35	—	20	—	15	—	ns
39	t _{CKHL}	X1 fall time (3.5 to 1.0 V)	—	5	—	5	—	5	ns
40	t _{CKLH}	X1 rise time (1.0 to 3.5 V)	—	5	—	5	—	5	ns
CLKIN Requirements for 1x PLL Mode									
36	t _{CKIN}	X1 period ²	40	60	25	60	Not Supported		ns
37	t _{CLCK}	X1 Low time (1.5 V)	15	—	7.5	—			ns
38	t _{CHCK}	X1 High time (1.5 V)	15	—	7.5	—			ns
39	t _{CKHL}	X1 fall time (3.5 to 1.0 V)	—	5	—	5			ns
40	t _{CKLH}	X1 rise time (1.0 to 3.5 V)	—	5	—	5			ns
CLKOUT Timing³									
42	t _{CLCL}	CLKOUT period	40	—	25	—	20	—	ns
43	t _{CLCH}	CLKOUT Low time (C _L = 50 pF)	0.5t _{CLCL} -2 = 18	—	0.5t _{CLCL} -1.25 = 11.25	—	0.5t _{CLCL} -1 = 9	—	ns
44	t _{CHCL}	CLKOUT High time (C _L = 50 pF)	0.5t _{CLCL} -2 = 18	—	0.5t _{CLCL} -1.25 = 11.25	—	0.5t _{CLCL} -1 = 9	—	ns
45	t _{CH1CH2}	CLKOUT rise time (1.0 to 3.5 V)	—	3	—	3	—	3	ns
46	t _{CL2CL1}	CLKOUT fall time (3.5 to 1.0 V)	—	3	—	3	—	3	ns
69	t _{CICO}	X1 to CLKOUT skew	—	10	—	10	—	10	ns

Notes:

1. All timing parameters are measured at V_{CC}/2 with 50-pF loading on CLKOUT unless otherwise noted. All output test conditions are with the load values shown in Table 30, "Pin List Summary," on page A-11.
2. Testing is performed with equal loading on referenced pins.
3. The PLL requires a maximum of 1 ms to achieve lock after all other operating conditions (V_{CC}) are stable, which is normally achieved by holding RES active for at least 1 ms.

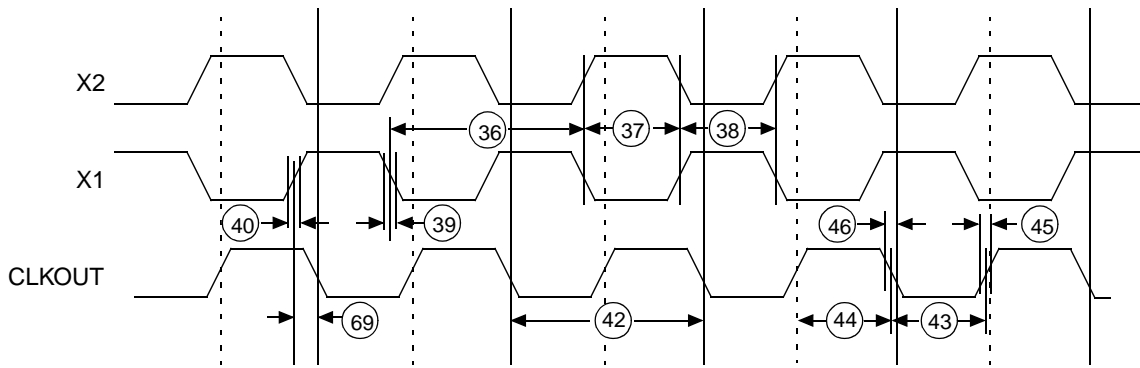

Figure 26. System Clocks Waveforms—Active Mode (PLL 1x Mode)

Table 19. PCM Highway Timing (Timing Slave)^{1, 2}

No.	Symbol	Parameter Description	Preliminary		Unit
			Min	Max	
1	t_{CLKP}	PCM clock period	200	—	ns
2	t_{WH}	PCM clock High	80	—	ns
3	t_{WL}	PCM clock Low	80	—	ns
4	t_{HCF}	Hold time from CLK Low to FSC valid	0	—	ns
5	t_{DZC}	Delay time to valid TXD from CLK	1	25	ns
6	t_{DZF}	Delay time to valid TXD from FSC	1	25	ns
7	t_{SUFC}	Setup time for FSC High to CLK Low	35	—	ns
8	t_{DCD}	Delay time from CLK High to TXD valid	1	25	ns
9	t_{SUDC}	Setup time from RXD valid to CLK	35	—	ns
10	t_{HCD}	Hold time from CLK Low to RXD invalid	5	—	ns
11	t_{DCT}	Delay to \overline{TSC} valid from CLK	1	25	ns
12	t_{DFT}	Delay to \overline{TSC} valid from FSC	1	25	ns
13	t_{DCLT}	Delay from CLK Low of last bit to \overline{TSC} invalid	1	25	ns
14	t_{HFI}	Hold time from CLK Low to FSC invalid	0	—	ns
15	t_{SYNSS}	Time between successive synchronization pulses	16	—	CLK
16	t_{WSYN}	FSC width invalid	8	—	CLK
17	t_{DTW} ³	Delay from last bit CLK Low to TXD weak drive	1	25	ns
18	t_{DTZ}	Delay from last bit CLK (plus 1) High to TXD disable	1	25	ns

Notes:

1. All timing parameters are measured at $V_{CC}/2$ with 50-pF loading on CLKOUT unless otherwise noted. All output test conditions are with the load values shown in Table 30, "Pin List Summary," on page A-11.
2. TXD becomes valid after the CLK rising edge or FSC enable, whichever is later.
3. During the second half of the last bit transmittal, TXD is driven weak so that other devices can safely drive during this time.

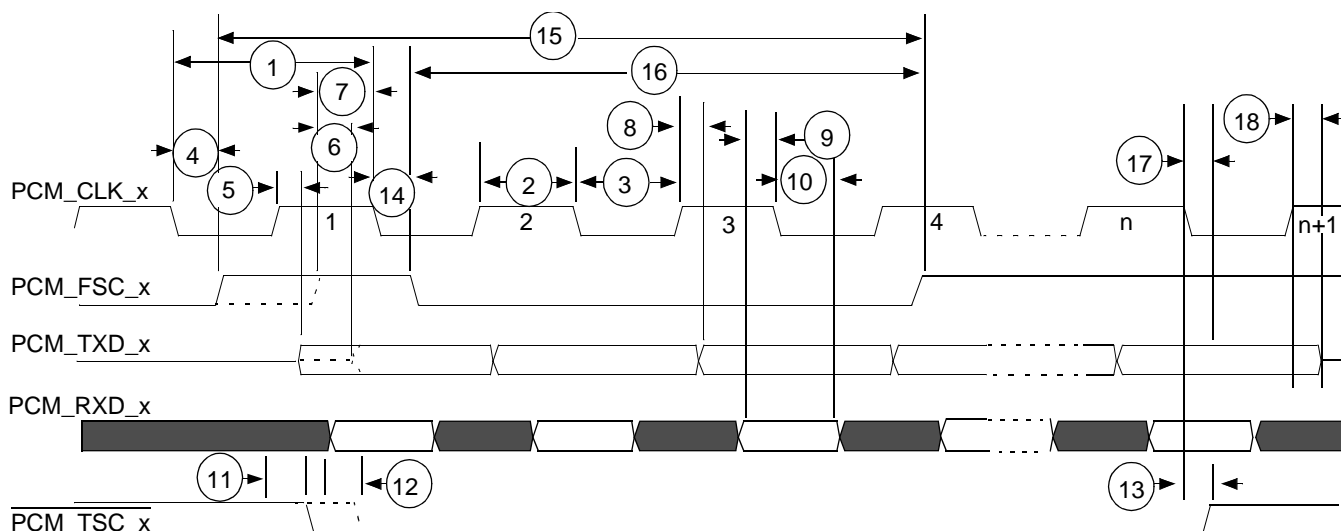

Notes:

The PCM_TXD_x outputs three-state. In the signal description and pin list summary tables, PCM_TXD_x is listed as O-LS-OD (totem pole output/programmable to hold last state of pin/open drain output) because of the following design characteristic:

On the last bit to be transmitted in PCM Highway mode, PCM_TXD_x will be driven normally during the first 1/2 bit time. During the last 1/2 bit time of the last bit of the transmission, PCM_TXD_x control will be in the hold-last-state condition (LS). In this condition, the output is driven, but at a much weaker strength. This permits another device (external to the microcontroller) to start driving during this time without bus contention problems. After this 1/2 bit time of hold-last-state condition, the PCM_TXD_x pin will be fully three-stated.

In some applications, several PCM Highway devices may have their PCM_TXD pins tied together. The time slot assigners should be programmed so that only one device is active at any time.

The PCM_TSC_x signal permits external bus drivers, possibly to go external to the board. Each PCM_TSC_x signal is open-drain so that multiple PCM_TSC_x pins can be connected together. For example, two Am186CH microcontrollers could be connected on the same PCM Highway and (with proper configuration of the time slot assigners) could occupy different time slots. An external bus driver would need to be active for both Am186CH time slots. The open drain on the PCM_TSC_x pins permits them to be wired together to achieve this.

Figure 27. PCM Highway Waveforms (Timing Slave)

Table 20. PCM Highway Timing (Timing Master)¹

Parameter			Preliminary		Unit
No.	Symbol	Description	Min	Max	
1	t _{DCFH}	Delay time from CLK High to FSC High	0	30	ns
2	t _{DCFL}	Delay time from CLK High to FSC Low	0	30	ns

Notes:

1. All timing parameters are measured at V_{CC}/2 with 50-pF loading on CLKOUT unless otherwise noted. All output test conditions are with the load values shown in Table 30, "Pin List Summary," on page A-11.

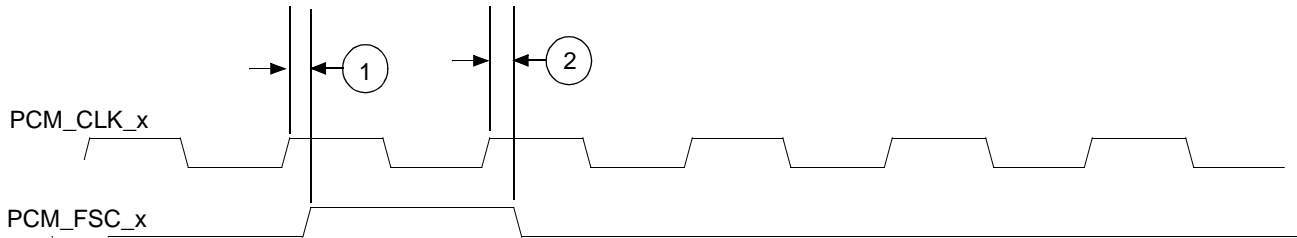

Figure 28. PCM Highway Waveforms (Timing Master)

Table 21. DCE Interface Timing^{1, 2}

No.	Symbol	Parameter	Preliminary		Unit
			Min	Max	
1	$t_{TCLKPER}$	DCE clock period	95	—	ns
2	t_{TCLKH}	DCE clock High	40	—	ns
3	t_{TCLKL}	DCE clock Low	40	—	ns
4	t_{TCLKO}	DCE clock to output delay	1	20	ns
5	t_{TCLKSU}	DCE clock setup	15	—	ns
6	t_{TCLKHD}	DCE clock hold	5	—	ns
7	t_{TCLKR}	DCE clock rise/fall	—	10	ns

Notes:

1. All timing parameters are measured at $V_{CC}/2$ with 50-pF loading on CLKOUT unless otherwise noted. All output test conditions are with the load values shown in Table 30, "Pin List Summary," on page A-11.
2. Timings are shown with TCLK and RCLK in the default mode without the optional clock inversion.

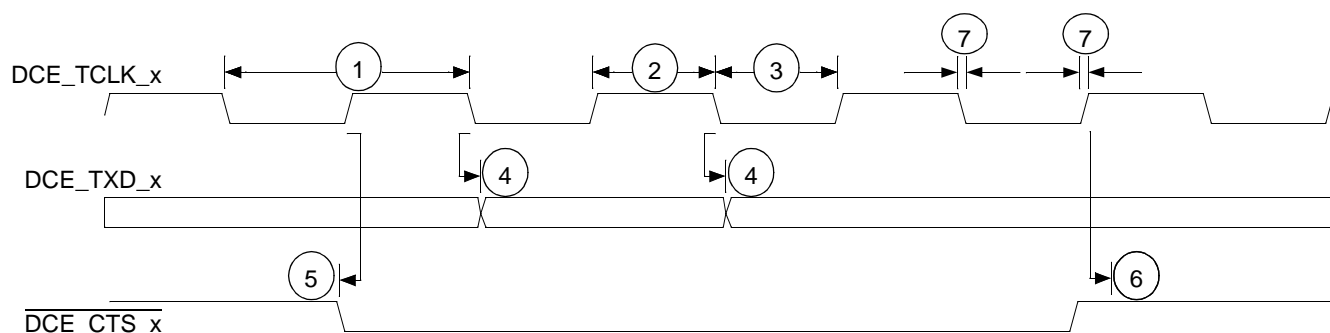

Figure 29. DCE Transmit Waveforms

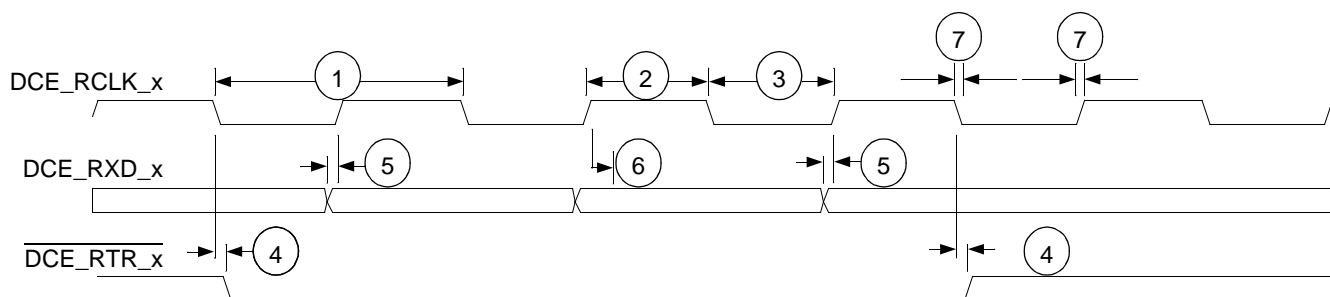

Figure 30. DCE Receive Waveforms

Table 22. SSI Timing¹

Parameter			Preliminary						Unit
			25 MHz		40 MHz		50 MHz (Commercial Only)		
No.	Symbol	Description	Min	Max	Min	Max	Min	Max	
1	t _{CLEV}	CLKOUT Low to SDEN valid	0	20	0	12	0	10	ns
2	t _{CLSL}	CLKOUT Low to SCLK Low	0	20	0	15	0	12	ns
3	t _{DVSH}	Data valid to SCLK High	10	—	5	—	5	—	ns
4	t _{SHDX}	SCLK High to data invalid	3	—	2	—	2	—	ns
5	t _{SLDV}	SCLK Low to data valid	—	20	—	12	—	10	ns

Notes:

1. All timing parameters are measured at V_{CC}/2 with 50-pF loading on CLKOUT unless otherwise noted. All output test conditions are with the load values shown in Table 30, "Pin List Summary," on page A-11.

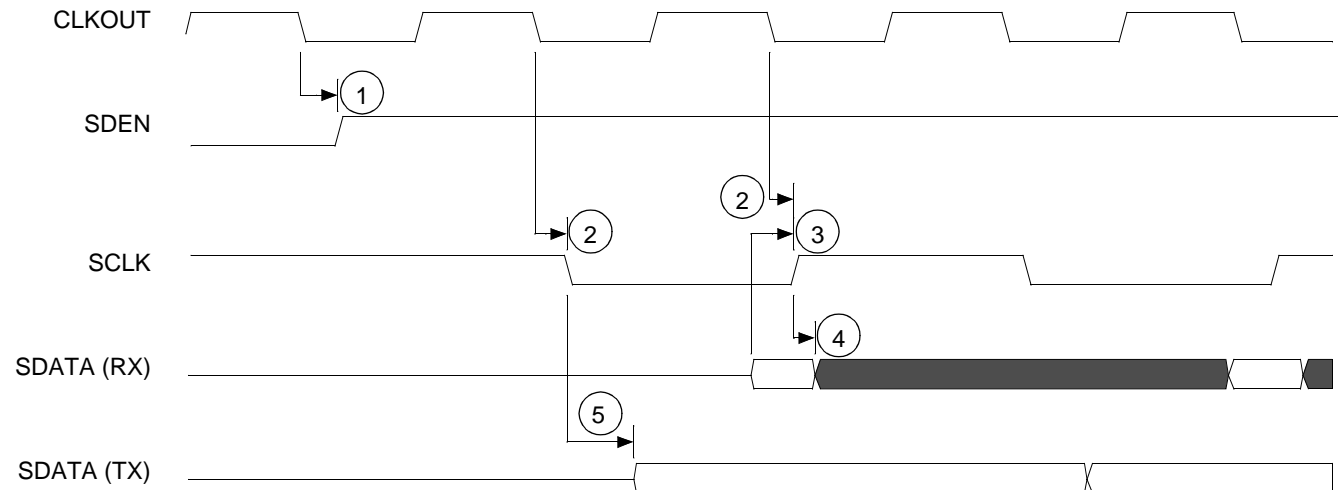

Notes:

1. SDEN is configured to be active High.
2. SCLK is configured to be CLKOUT/2.
3. Waveforms are shown for "normal" clock mode (i.e., transmit on negative edge of SCLK and receive on positive edge of SCLK).

Figure 31. SSI Waveforms

Table 23. DRAM Timing¹

Parameter			Preliminary						Unit
			25 MHz		40 MHz		50 MHz (Commercial Only)		
No.	Symbol	Description	Min	Max	Min	Max	Min	Max	
1	t _{DVCL}	Data in setup	10	—	5	—	5	—	ns
2	t _{CLDX}	Data in hold	3	—	2	—	2	—	ns
5	t _{CLAV}	AD address valid delay	0	20	0	12	0	10	ns
7	t _{CLDV}	Data valid delay	0	20	0	12	0	10	ns
15	t _{CLAZ}	AD address float delay	0	20	0	12	0	10	ns
20	t _{CVCTV}	Control active delay 1	0	20	0	12	0	10	ns
25	t _{CLRL}	\overline{RD} active delay	0	20	0	12	0	10	ns
27	t _{CLRH}	\overline{RD} inactive delay	0	20	0	12	0	10	ns
30	t _{CLDOX}	Data hold time	0	—	0	—	0	—	ns
31	t _{CVCTX}	Control inactive delay	0	20	0	12	0	10	ns
68	t _{CHAV}	CLKOUT High to A address valid	0	20	0	12	0	10	ns
402	t _{COLV}	Column address valid delay	0	20	0	12	0	10	ns
403	t _{CHRAS}	Change in \overline{RAS} delay	3	20	3	12	3	10	ns
404	t _{CHCAS}	Change in \overline{CAS} delay	3	20	3	12	3	10	ns

Notes:

1. All timing parameters are measured at $V_{CC}/2$ with 50-pF loading on CLKOUT unless otherwise noted. All output test conditions are with the load values shown in Table 30, "Pin List Summary," on page A-11.

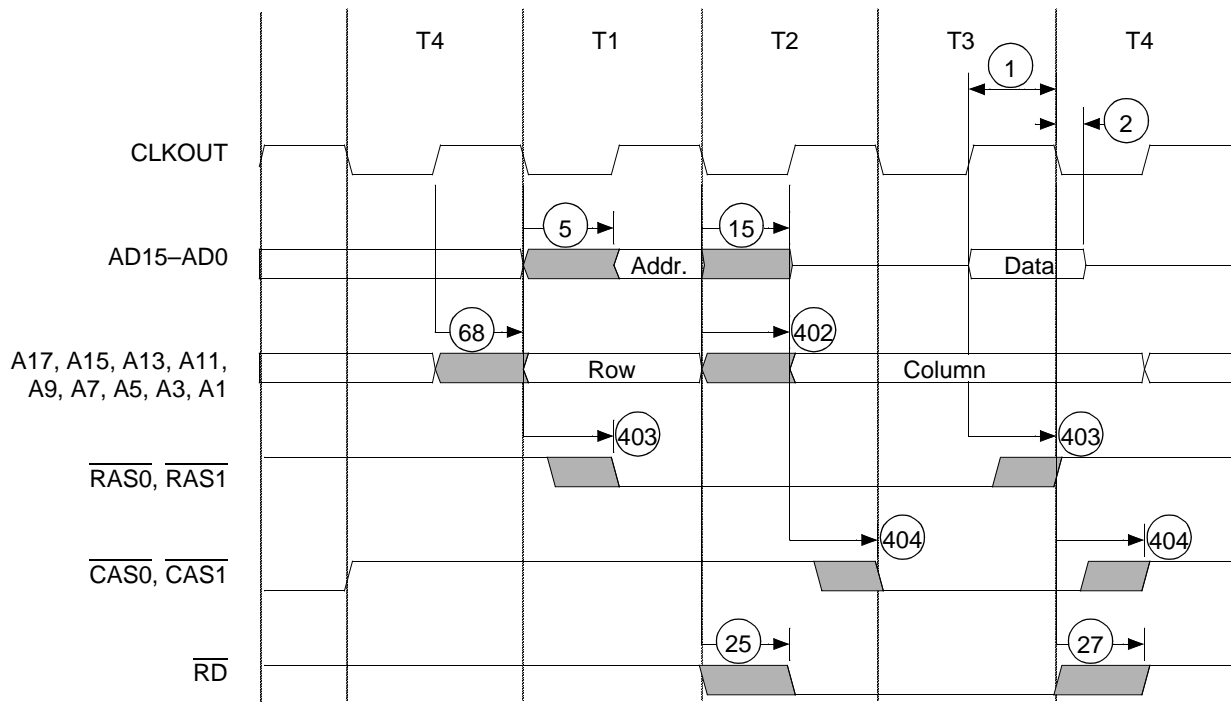

Figure 32. DRAM Read Cycle without Wait States Waveform

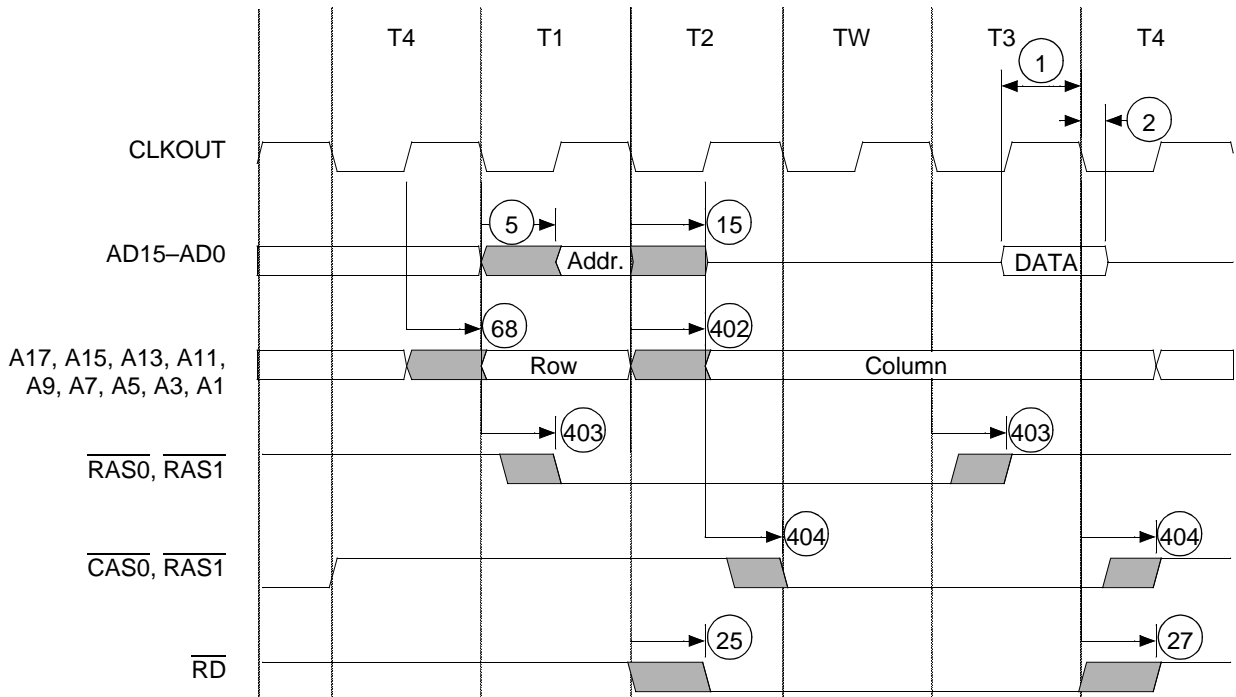

Figure 33. DRAM Read Cycle with Wait States Waveform

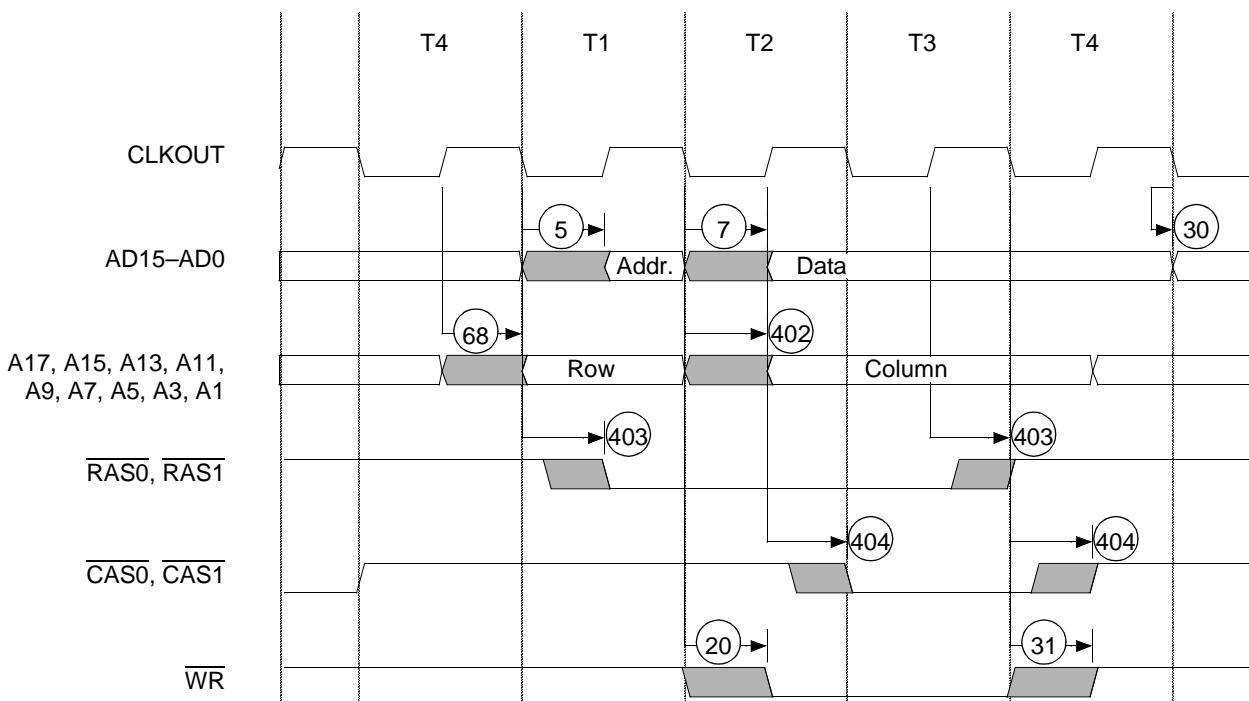

Figure 34. DRAM Write Cycle without Wait States Waveform

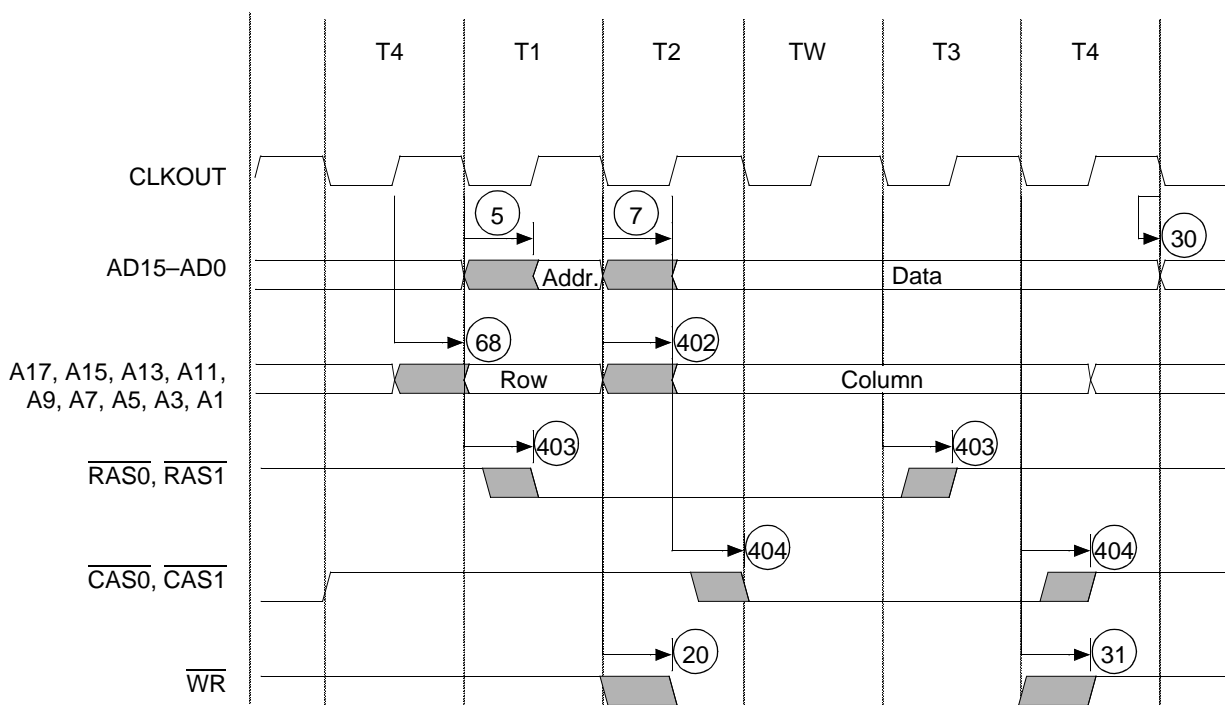

Figure 35. DRAM Write Cycle with Wait States Waveform

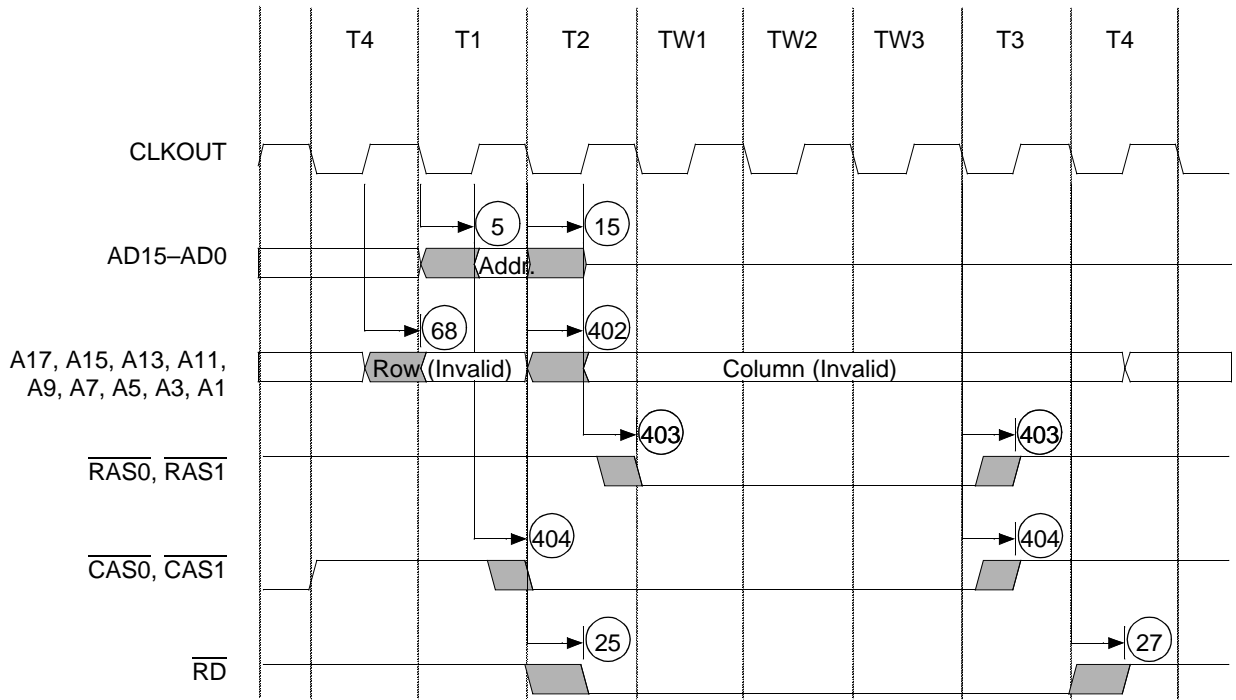

Figure 36. DRAM Refresh Cycle Waveform

APPENDIX A—PIN TABLES

This appendix contains pin tables for the Am186CH HDLC microcontroller. Several different tables are included with the following characteristics:

- Power-on reset (POR) pin defaults including pin numbers and multiplexed functions—Table 24 on page A-2.
- Multiplexed signal trade-offs—Table 25 on page A-5.
- Pinstrips and pinstrap options—Table 26 on page A-7.
- Programmable I/O pins ordered by PIO pin number and multiplexed signal name, respectively, including pin numbers, multiplexed functions, and pin configurations following system reset—Table 27 on page A-8 and Table 28 on page A-9.
- Pin and signal summary showing signal name and alternate function, pin number, I/O type, maximum load values, POR default function, reset state, POR default operation, hold state, and voltage column—Table 30 on page A-11.

For pin tables showing pins sorted by pin number and signal name, respectively, see Table 1, “PQFP Pin Assignments—Sorted by Pin Number” on page 10 and Table 2, “PQFP Pin Assignments—Sorted by Signal Name” on page 11.

For signal descriptions, see Table 4, “Signal Descriptions” on page 13.

In all tables the brackets, [], indicate alternate, multiplexed functions, and braces, { }, indicate reset configuration pins (pinstraps). The line over a pin name indicates an active Low. The word pin refers to the physical wire; the word signal refers to the electrical signal that flows through it.

Table 24. Power-On Reset (POR) Pin Defaults¹

POR Default	Pin Number	Multiplexed Signal	Multiplexed Signal	Multiplexed Signal	PIO	Pinstrap
Bus Interface Unit						
A0	30	—	—	—	—	—
A1	31	—	—	—	—	—
A2	32	—	—	—	—	—
A3	36	—	—	—	—	—
A4	37	—	—	—	—	—
A5	42	—	—	—	—	—
A6	43	—	—	—	—	—
A7	44	—	—	—	—	—
A8	45	—	—	—	—	—
A9	49	—	—	—	—	—
A10	50	—	—	—	—	—
A11	64	—	—	—	—	—
A12	65	—	—	—	—	—
A13	69	—	—	—	—	—
A14	70	—	—	—	—	—
A15	84	—	—	—	—	—
A16	85	—	—	—	—	—
A17	88	—	—	—	—	—
A18	89	—	—	—	—	—
A19	90	—	—	—	—	—
AD0	28	—	—	—	—	—
AD1	34	—	—	—	—	—
AD2	38	—	—	—	—	—
AD3	46	—	—	—	—	—
AD4	51	—	—	—	—	—
AD5	66	—	—	—	—	—
AD6	86	—	—	—	—	—
AD7	92	—	—	—	—	—
AD8	29	—	—	—	—	—
AD9	35	—	—	—	—	—
AD10	39	—	—	—	—	—
AD11	47	—	—	—	—	—
AD12	52	—	—	—	—	—
AD13	67	—	—	—	—	—
AD14	87	—	—	—	—	—
AD15	93	—	—	—	—	—
ALE	19	—	—	—	PIO33	—
ARDY	14	—	—	—	PIO8	—
BHE	20	—	—	—	PIO34	{ADEN}
BSIZE8	94	—	—	—	—	—
DEN	18	DS	—	—	PIO30	—
DRQ1	105	—	—	—	—	—
DT/R	17	—	—	—	PIO29	—
HLDA	98	—	—	—	—	—
HOLD	99	—	—	—	—	{CLKSEL1}
RD	97	—	—	—	—	—
S0	57	—	—	—	—	—
S1	56	—	—	—	—	—
S2	55	—	—	—	—	—

Table 24. Power-On Reset (POR) Pin Defaults¹ (Continued)

POR Default	Pin Number	Multiplexed Signal	Multiplexed Signal	Multiplexed Signal	PIO	Pinstrap
S6	54	—	—	—	—	—
SRDY	15	—	—	—	PIO35	—
WHB	95	—	—	—	—	—
WLB	96	—	—	—	—	—
WR	16	—	—	—	PIO15	—
Chip Selects						
LCS	131	RAS0	—	—	—	—
MCS1	127	CAS1	—	—	—	—
MCS2	128	CAS0	—	—	—	—
PCS0	5	—	—	—	PIO13	—
PCS1	6	—	—	—	PIO14	—
PCS2	7	—	—	—	—	—
PCS3	8	—	—	—	—	—
UCS	132	—	—	—	—	{ONCE}
Reset/Clocks						
CLKOUT	60	—	—	—	—	—
RES	114	—	—	—	—	—
RESOUT	58	—	—	—	—	—
X1	73	—	—	—	—	—
X2	74	—	—	—	—	—
Interrupts						
INT0	107	—	—	—	—	—
INT1	109	—	—	—	—	—
INT2	110	—	—	—	—	—
INT3	111	—	—	—	—	—
INT4	112	—	—	—	—	—
INT5	113	—	—	—	—	—
NMI	115	—	—	—	—	—
Synchronous Communications Interfaces						
Channel A (DCE)						
DCE_RXD_A	118	PCM_RXD_A	—	—	—	—
DCE_TXD_A	119	PCM_TXD_A	—	—	—	—
DCE_RCLK_A	117	PCM_CLK_A	—	—	—	—
DCE_TCLK_A	116	PCM_FSC_A	—	—	—	—
High-Speed UART						
TXD_HU	26	—	—	—	—	—
Debug Support						
QS0	62	—	—	—	—	—
QS1	63	—	—	—	—	—
PIOs						
PIO0	144	TMRIN1	—	—		—
PIO1	143	TMROUT1	—	—		—
PIO2	10	PCS5	—	—		—
PIO3	9	PCS4	—	—		{CLKSEL2}
PIO4	126	MCS0	—	—		{UCSX8}
PIO5	129	MCS3	RAS1	—		—
PIO6	147	INT8	PWD	—		—
PIO7	146	INT7	—	—		—
PIO9	124	DRQ0	—	—		—
PIO10	2	SDEN	—	—		—

Table 24. Power-On Reset (POR) Pin Defaults¹ (Continued)

POR Default	Pin Number	Multiplexed Signal	Multiplexed Signal	Multiplexed Signal	PIO	Pinstrap
PIO11	3	SCLK	—	—		—
PIO12	4	SDATA	—	—		—
PIO16	25	RXD_HU	—	—		—
PIO17	123	DCE_CTS_A	PCM_TSC_A	—		—
PIO18	122	DCE_RTR_A	—	—		—
PIO19	145	INT6	—	—		—
PIO20	159	TXD_U	—	—		—
PIO21	22	UCLK	—	—		—
PIO22	150	—	—	—		—
PIO23	149	—	—	—		—
PIO24	157	CTS_U	—	—		—
PIO25	156	RTR_U	—	—		—
PIO26	158	RXD_U	—	—		—
PIO27	142	TMRIN0	—	—		—
PIO28	141	TMROUT0	—	—		—
PIO31	13	PCS7	—	—		—
PIO32	11	PCS6	—	—		—
PIO36	138	DCE_RXD_B	PCM_RXD_B	—		—
PIO37	139	DCE_TXD_B	PCM_TXD_B	—		—
PIO38	137	DCE_CTS_B	PCM_TSC_B	—		—
PIO39	136	DCE_RTR_B	—	—		—
PIO40	135	DCE_RCLK_B	PCM_CLK_B	—		—
PIO41	134	DCE_TCLK_B	PCM_FSC_B	—		—
PIO42	153	—	—	—		—
PIO43	154	—	—	—		—
PIO44	152	—	—	—		—
PIO45	151	—	—	—		—
PIO46	24	CTS_HU	—	—		—
PIO47	23	RTR_HU	—	—		—
Reserved						
RSVD_104	104	—	—	—	—	—
RSVD_103	103	—	—	—	—	—
RSVD_102	102	—	—	—	—	—
RSVD_101	101	—	—	—	—	—
RSVD_81	81	—	—	—	—	—
RSVD_80	80	—	—	—	—	—
RSVD_76	76	—	—	—	—	—
RSVD_75	75	—	—	—	—	—

Notes:

1. For default reset functions and pin states refer to Table 30, “Pin List Summary,” on page A-11.

Table 25. Multiplexed Signal Trade-Offs

DESIRED FUNCTION			LOST FUNCTION								
Interface	Name	Pin	Interface	Name	Interface	Name	Interface	Name	Interface	Name	
Memory											
SRAM	$\overline{\text{LCS}}$	131	DRAM	$\overline{\text{RAS0}}$	—	—	—	—	PIO	—	
	$\overline{\text{MCS1}}$	127		$\overline{\text{CAS1}}$	—	—	—	—		—	
	$\overline{\text{MCS2}}$	128		$\overline{\text{CAS0}}$	—	—	—	—		—	
	$\overline{\text{MCS3}}$	129		$\overline{\text{RAS1}}$	—	—	—	—	PIO5		
DRAM	$\overline{\text{CAS0}}$	128	SRAM	$\overline{\text{MCS2}}$	—	—	—	—	—	—	
	$\overline{\text{CAS1}}$	127		$\overline{\text{MCS1}}$	—	—	—	—	—		
	$\overline{\text{RAS0}}$	131		$\overline{\text{LCS}}$	—	—	—	—	—		
	$\overline{\text{RAS1}}$	129		$\overline{\text{MCS3}}$	—	—	—	—	PIO5		
Synchronous Communications Interfaces											
DCE Channel A	DCE_RXD_A	118	PCM Channel A	PCM_RXD_A	—	—	—	—	PIO	—	
	DCE_TXD_A	119		PCM_TXD_A	—	—		—		—	
	DCE_RCLK_A	117		PCM_CLK_A	—	—		—		—	
	DCE_TCLK_A	116		PCM_FSC_A	—	—		—		—	
	DCE_CTS_A	123		PCM_TSC_A	—	—		—		—	PIO17
	DCE_RTR_A	122		—	—	—		—	—	PIO18	
DCE Channel B	DCE_RXD_B	138	PCM Channel B	PCM_RXD_B	—	—	—	—	PIO	PIO36	
	DCE_TXD_B	139		PCM_TXD_B	—	—		—		—	PIO37
	DCE_RCLK_B	135		PCM_CLK_B	—	—		—		—	PIO40
	DCE_TCLK_B	134		PCM_FSC_B	—	—		—		—	PIO41
	DCE_CTS_B	137		PCM_TSC_B	—	—		—		—	PIO38
	DCE_RTR_B	136		—	—	—		—		—	PIO39
PCM Channel A	PCM_RXD_A	118	DCE Channel A	DCE_RXD_A	—	—	—	—	PIO	—	
	PCM_TXD_A	119		DCE_TXD_A	—	—		—		—	
	PCM_CLK_A	117		DCE_RCLK_A	—	—		—		—	
	PCM_FSC_A	116		DCE_TCLK_A	—	—		—		—	
	PCM_TSC_A	123		DCE_CTS_A	—	—		—		—	PIO17
PCM Channel B	PCM_RXD_B	138	DCE Channel B	DCE_RXD_B	—	—	—	—	PIO	PIO36	
	PCM_TXD_B	139		DCE_TXD_B	—	—		—		—	PIO37
	PCM_CLK_B	135		DCE_RCLK_B	—	—		—		—	PIO40
	PCM_FSC_B	134		DCE_TCLK_B	—	—		—		—	PIO41
	PCM_TSC_B	137		DCE_CTS_B	—	—		—		—	PIO38
Low-Speed UART	RXD_U	158	—	—	—	—	—	—	PIO	PIO26	
	TXD_U	159	—	—	—	—	—	—		PIO20	
	RTR_U	156	—	—	—	—	—	—		PIO25	
	CTS_U	157	—	—	—	—	—	—		PIO24	
High-Speed UART	RXD_HU	25	—	—	—	—	—	—	PIO	PIO16	
	RTR_HU	23	—	—	—	—	—	—		PIO47	
	CTS_HU	24	—	—	—	—	—	—		PIO46	
Miscellaneous											
Bus Interface	DEN	18	Bus Interface	$\overline{\text{DS}}$	—	—	—	—	—	PIO30	
	$\overline{\text{DS}}$	18		DEN	—	—	—	—	—	PIO30	
PIOs											
	PIO0	144		TMRIN1		—		—			
	PIO1	143		TMROUT1		—		—			
	PIO2	10		$\overline{\text{PCS5}}$		—		—			
	PIO3	9		$\overline{\text{PCS4}}$		—		—			
	PIO4	126		$\overline{\text{MCS0}}$		—		—			
	PIO5	129		$\overline{\text{MCS3}}$			RAS1	—			

Table 25. Multiplexed Signal Trade-Offs (Continued)

DESIRED FUNCTION			LOST FUNCTION							
Interface	Name	Pin	Interface	Name	Interface	Name	Interface	Name	Interface	Name
	PIO6	147		INT8		PWD		—		
	PIO7	146		INT7		—		—		
	PIO8	14		ARDY		—		—		
	PIO9	124		DRQ0		—		—		
	PIO10	2		SDEN		—		—		
	PIO11	3		SCLK		—		—		
	PIO12	4		SDATA		—		—		
	PIO13	5		PCS0		—		—		
	PIO14	6		PCS1		—		—		
	PIO15	16		WR		—		—		
	PIO16	25		RXD_HU		—		—		
	PIO17	123		DCE_CTS_A		PCM_TSC_A		—		
	PIO18	122		DCE_RTR_A		—		—		
	PIO19	145		INT6		—		—		
	PIO20	159		TXD_U		—		—		
	PIO21	22		UCLK		—		—		
	PIO22	150		—		—		—		
	PIO23	149		—		—		—		
	PIO24	157		CTS_U		—		—		
	PIO25	156		RTR_U		—		—		
	PIO26	158		RXD_U		—		—		
	PIO27	142		TMRIN0		—		—		
	PIO28	141		TMROUT0		—		—		
	PIO29	17		DT/R		—		—		
	PIO30	18		DEN		DS		—		
	PIO31	13		PCS7		—		—		
	PIO32	11		PCS6		—		—		
	PIO33	19		ALE		—		—		
	PIO34	20		BHE		—		—		
	PIO35	15		SRDY		—		—		
	PIO36	138		DCE_RXD_B		PCM_RXD_B		—		
	PIO37	139		DCE_TXD_B		PCM_TXD_B		—		
	PIO38	137		DCE_CTS_B		PCM_TSC_B		—		
	PIO39	136		DCE_RTR_B		—		—		
	PIO40	135		DCE_RCLK_B		PCM_CLK_B		—		
	PIO41	134		DCE_TCLK_B		PCM_FSC_B		—		
	PIO42	153		—		—		—		
	PIO43	154		—		—		—		
	PIO44	152		—		—		—		
	PIO45	151		—		—		—		
	PIO46	24		CTS_HU		—		—		
	PIO47	23		RTR_HU		—		—		

Table 26. Reset Configuration Pins (Pinstraps)¹

Signal Name	Multiplexed Signal(s)	Description															
{ $\overline{\text{ADEN}}$ }	$\overline{\text{BHE}}$ PIO34	<p>Address Enable: If {$\overline{\text{ADEN}}$} is held High or left floating during power-on reset, the address portion of the AD bus (AD15–AD0) is enabled or disabled during $\overline{\text{LCS}}$, $\overline{\text{UCS}}$, or other memory bus cycles based on how the software configures the DA bit setting. In this case, the memory address is accessed on the A19–A0 pins. There is a weak internal pullup resistor on {$\overline{\text{ADEN}}$} so no external pullup is required. This mode of operation reduces power consumption.</p> <p>If {$\overline{\text{ADEN}}$} is held Low on power-on reset, the AD bus drives both addresses and data, regardless of how software configures the DA bit setting.</p>															
{ $\overline{\text{CLKSEL1}}$ }	HLDA	<p>CPU PLL Mode Select 1 determines the PLL mode for the system clock source.</p> <p>CPU PLL Mode Select 2 is sampled on the rising edge of reset and determines the PLL mode for the system clock source. This pin has an internal pullup resistor that is active only during reset. There are four CPU PLL modes that are selected by the values of {$\overline{\text{CLKSEL1}}$} and {$\overline{\text{CLKSEL2}}$} as shown below. (For details on clocks see “Clock Generation and Control” on page 33.)</p> <p>CPU PLL Modes</p> <table border="1"> <thead> <tr> <th>{$\overline{\text{CLKSEL1}}$}</th> <th>{$\overline{\text{CLKSEL2}}$}</th> <th>CPU PLL Mode</th> </tr> </thead> <tbody> <tr> <td>1</td> <td>1</td> <td>2X, CPU PLL enabled (default)</td> </tr> <tr> <td>1</td> <td>0</td> <td>4X, CPU PLL enabled</td> </tr> <tr> <td>0</td> <td>1</td> <td>1X, CPU PLL enabled</td> </tr> <tr> <td>0</td> <td>0</td> <td>PLL Bypass</td> </tr> </tbody> </table>	{ $\overline{\text{CLKSEL1}}$ }	{ $\overline{\text{CLKSEL2}}$ }	CPU PLL Mode	1	1	2X, CPU PLL enabled (default)	1	0	4X, CPU PLL enabled	0	1	1X, CPU PLL enabled	0	0	PLL Bypass
{ $\overline{\text{CLKSEL1}}$ }	{ $\overline{\text{CLKSEL2}}$ }		CPU PLL Mode														
1	1	2X, CPU PLL enabled (default)															
1	0	4X, CPU PLL enabled															
0	1	1X, CPU PLL enabled															
0	0	PLL Bypass															
{ $\overline{\text{CLKSEL2}}$ }	$\overline{[\text{PCS4}]}$ PIO3																
{ $\overline{\text{ONCE}}$ }	$\overline{\text{UCS}}$	<p>ONCE Mode Request asserted Low places the Am186CH HDLC microcontroller into ONCE mode. Otherwise, the controller operates normally. In ONCE mode, all pins are three-stated and remain in that state until a subsequent reset occurs. To guarantee that the controller does not inadvertently enter ONCE mode, {$\overline{\text{ONCE}}$} has a weak internal pullup resistor that is active only during a reset. A reset ending ONCE mode should be as long as a power-on reset so that the PLL will stabilize.</p>															
{ $\overline{\text{UCSX8}}$ }	$\overline{[\text{MCS0}]}$ PIO4	<p>Upper Memory Chip Select, 8-Bit Bus asserted Low configures the upper chip select region for an 8-bit bus size. This pin has a pullup resistor that is active only during reset, so no external pullup is required to set the bus to 16-bit mode.</p>															

Notes:

1. A pinstrap is used to enable or disable features based on the state of the pin during an external reset. The pinstrap must be held in its desired state for at least 4.5 clock cycles after the deassertion of $\overline{\text{RES}}$. The pinstraps are sampled in an external reset only (when $\overline{\text{RES}}$ is asserted), not during an internal watchdog timer-generated reset.

Table 27. PIOs Sorted by PIO Number

PIO No.	Pin No.	Multiplexed Signal	Multiplexed Signal	Multiplexed Signal	Pin Configuration Following System Reset ¹
PIO0	144	TMRIN1	—	—	Input with pullup
PIO1	143	TMROUT1	—	—	Input with pulldown
PIO2	10	PCS5	—	—	Input with pullup
PIO3	9	PCS4	—	—	Input with pullup
PIO4	126	MCS0	—	—	Input with pullup
PIO5	129	MCS3	RAS1	—	Input with pullup
PIO6	147	INT8	PWD	—	Input with pullup
PIO7	146	INT7	—	—	Input with pullup
PIO8	14	ARDY	—	—	Alternate operation ²
PIO9	124	DRQ0	—	—	Input with pulldown
PIO10	2	SDEN	—	—	Input with pulldown
PIO11	3	SCLK	—	—	Input with pullup
PIO12	4	SDATA	—	—	Input with pullup
PIO13	5	PCS0	—	—	Alternate operation ²
PIO14	6	PCS1	—	—	Alternate operation ²
PIO15	16	WR	—	—	Alternate operation ²
PIO16	25	RXD_HU	—	—	Input with pullup
PIO17	123	DCE_CTS_A	PCM_TSC_A	—	Input with pullup
PIO18	122	DCE_RTR_A	—	—	Input with pullup
PIO19	145	INT6	—	—	Input with pullup
PIO20	159	TXD_U	—	—	Input with pullup
PIO21	22	UCLK	—	—	Input with pullup
PIO22	150	—	—	—	Input with pulldown
PIO23	149	—	—	—	Input with pulldown
PIO24	157	CTS_U	—	—	Input with pullup
PIO25	156	RTR_U	—	—	Input with pullup
PIO26	158	RXD_U	—	—	Input with pullup
PIO27	142	TMRIN0	—	—	Input with pullup
PIO28	141	TMROUT0	—	—	Input with pulldown
PIO29	17	DT/R	—	—	Alternate operation ²
PIO30	18	DEN	DS	—	Alternate operation ²
PIO31	13	PCS7	—	—	Input with pullup
PIO32	11	PCS6	—	—	Input with pullup
PIO33	19	ALE	—	—	Alternate operation ³
PIO34	20	BHE	—	—	Alternate operation ²
PIO35	15	SRDY	—	—	Alternate operation ²
PIO36	138	DCE_RXD_B	PCM_RXD_B	—	Input with pullup
PIO37	139	DCE_TXD_B	PCM_TXD_B	—	Input with pullup
PIO38	137	DCE_CTS_B	PCM_TSC_B	—	Input with pullup
PIO39	136	DCE_RTR_B	—	—	Input with pullup
PIO40	135	DCE_RCLK_B	PCM_CLK_B	—	Input with pullup
PIO41	134	DCE_TCLK_B	PCM_FSC_B	—	Input with pullup
PIO42	153	—	—	—	Input with pulldown
PIO43	154	—	—	—	Input with pulldown
PIO44	152	—	—	—	Input with pullup
PIO45	151	—	—	—	Input with pullup
PIO46	24	CTS_HU	—	—	Input with pullup
PIO47	23	RTR_HU	—	—	Input with pullup

Notes:

1. System reset is defined as a power-on reset (i.e., the $\overline{\text{RES}}$ input pin transitioning from its Low to High state) or a reset due to a watchdog timer timeout.
2. When used as a PIO, input with pullup option available.
3. When used as a PIO, input with a pulldown option available.

Table 28. PIOs Sorted by Signal Name

Signal	PIO No.	Pin No.	Multiplexed Signal	Multiplexed Signal	Pin Configuration Following System Reset ¹
ALE	PIO33	19	—	—	Alternate operation ²
ARDY	PIO8	14	—	—	Alternate operation ³
BHE	PIO34	20	—	—	Alternate operation ³
CTS_HU	PIO46	24	—	—	Input with pullup
CTS_U	PIO24	157	—	—	Input with pullup
DCE_CTS_A	PIO17	123	PCM_TSC_A	—	Input with pullup
DCE_CTS_B	PIO38	137	PCM_TSC_B	—	Input with pullup
DCE_RCLK_B	PIO40	135	PCM_CLK_B	—	Input with pullup
DCE_RTR_A	PIO18	122	—	—	Input with pullup
DCE_RTR_B	PIO39	136	—	—	Input with pullup
DCE_RXD_B	PIO36	138	PCM_RXD_B	—	Input with pullup
DCE_TCLK_B	PIO41	134	PCM_FSC_B	—	Input with pullup
DCE_TXD_B	PIO37	139	PCM_TXD_B	—	Input with pullup
DEN	PIO30	18	DS	—	Alternate operation ³
DRQ0	PIO9	124	—	—	Input with pulldown
DT/R	PIO29	17	—	—	Alternate operation ³
INT6	PIO19	145	—	—	Input with pullup
INT7	PIO7	146	—	—	Input with pullup
INT8	PIO6	147	PWD	—	Input with pullup
MCS0	PIO4	126	—	—	Input with pullup
MCS3	PIO5	129	RAS1	—	Input with pullup
PCS0	PIO13	5	—	—	Alternate operation ³
PCS1	PIO14	6	—	—	Alternate operation ³
PCS4	PIO3	9	—	—	Input with pullup
PCS5	PIO2	10	—	—	Input with pullup
PCS6	PIO32	11	—	—	Input with pullup
PCS7	PIO31	13	—	—	Input with pullup
PIO22	—	150	—	—	Input with pulldown
PIO23	—	149	—	—	Input with pulldown
PIO42	—	153	—	—	Input with pulldown
PIO43	—	154	—	—	Input with pulldown
PIO44	—	152	—	—	Input with pullup
PIO45	—	151	—	—	Input with pullup
RTR_HU	PIO47	23	—	—	Input with pullup
RTR_U	PIO25	156	—	—	Input with pullup
RXD_HU	PIO16	25	—	—	Input with pullup
RXD_U	PIO26	158	—	—	Input with pullup
SCLK	PIO11	3	—	—	Input with pullup
SDATA	PIO12	4	—	—	Input with pullup
SDEN	PIO10	2	—	—	Input with pulldown
SRDY	PIO35	15	—	—	Alternate operation ³
TMRIN0	PIO27	142	—	—	Input with pullup
TMRIN1	PIO0	144	—	—	Input with pullup
TMROUT0	PIO28	141	—	—	Input with pulldown
TMROUT1	PIO1	143	—	—	Input with pulldown
TXD_U	PIO20	159	—	—	Input with pullup
UCLK	PIO21	22	—	—	Input with pullup
UCLK	PIO21	22	—	—	Input with pullup
WR	PIO15	16	—	—	Alternate operation ³

Notes:

1. System reset is defined as a power-on reset (i.e., the \overline{RES} input pin transitioning from its Low to High state) or a reset due to a watchdog timer timeout.
2. When used as a PIO, input with a pulldown option available.
3. When used as a PIO, input with a pullup option available.

Pin List Table Column Definitions

The following paragraphs describe the individual columns of information in Table 30, “Pin List Summary,” on page A-11. The pins are grouped alphabetically by function.

Note: All maximum delay numbers should be increased by 0.035 ns for every pF of load (up to a maximum of 150 pF) over the maximum load specified in Table 30.

Column #1—Signal Name, [Alternate Function], {Pinstrap}

This column denotes the primary and alternate functions of the pins. Most of the pins that have alternate functions are configured for these functions via firmware modifying values in the Peripheral Control Block. Refer to the *Am186™CC/CH/CU Microcontrollers Register Set Manual*, order #21916, for full documentation of this process.

Brackets, [], are used to indicate the alternate, multiplexed function of a pin (i.e., not power-on reset default).

Braces, { }, are used to indicate the functionality of a pin only during a processor reset. These signals are called pinstraps. To select the desired configuration, the pinstraps are terminated internally with pullup resistors or externally with pulldown resistors. Their state is sampled during a processor reset and latched on the rising edge of reset. The signals must be held in the desired state for 4.5 system clock cycles after the deassertion of reset. Based on the pinstrap’s state at the time they are latched, certain features of the Am186CH HDLC microcontroller are enabled or disabled. All external termination should be implemented with 10-Kohm resistors on these signals.

The pinstraps are listed in Table 26, “Reset Configuration Pins (Pinstraps),” on page A-7.

Column #2—Pin No.

The pin number column identifies the pin number of the individual I/O signal on the package.

Column #3—Type

Definitions of the abbreviations in the Type column are shown in Table 29.

Table 29. Pin List Table Definitions

Type	Definition
[]	Pin alternate function
{ }	Pinstrap pin
B	Bidirectional
H	High
LS	Programmable to hold last state of pin
O	Totem pole output
OD	Open drain output
OD-O	Open drain output or totem pole output
PD	Internal pulldown resistor
PU	Internal pullup resistor
STI	Schmitt trigger Input
STI-OD	Schmitt trigger input or open drain output
TS	Three-state output

Column #4—Max Load (pF)

The Max Load column designates the capacitive load at which the I/O timing for that pin is guaranteed.

Column #5—POR Default Function

The POR Default Function column shows the status of these pins after a power-on reset. In some cases the pin is the function outlined in the “Signal Name” column of the table. The signal name is listed in the POR Default Function column if the signal is the default function and not a PIO after a processor reset. In other cases the pin is a PIO configured as an input.

Column #6—Reset State

The Reset State column indicates the termination present on the signal at reset (pullup or pulldown) and indicates whether the signal is a three-stated output or a Schmitt trigger input. Refer to Table 29 for abbreviations used in this column.

Column #7—POR Default Operation

The POR Default Operation column describes the type of input and/or output that is default pin operation. Refer to Table 29 for abbreviations used in this column.

Column #8—Hold State

The Hold State column shows the state of the pin in hold state. Refer to Table 29 for abbreviations used in this column.

Column #9—5 V

A "5 V" in the 5-V column indicates 5-V tolerant inputs. These inputs are not damaged and do not draw excess power when driven with levels up to $V_{CC} + 2.6$ volts. These pins only drive to V_{CC} .

Table 30. Pin List Summary

Signal Name [Alternate Function] {Pinstrap}	Pin No.	Type	Max Load (pF)	POR Default Function	Reset State	POR Default Operation	Hold State	5 V
BUS INTERFACE/GENERAL-PURPOSE DMA REQUEST								
A0	30	O	70	A0	TS-PD	O	TS-PD	5 V
A1	31	O	70	A1	TS-PD	O	TS-PD	5 V
A2	32	O	70	A2	TS-PD	O	TS-PD	5 V
A3	36	O	70	A3	TS-PD	O	TS-PD	5 V
A4	37	O	70	A4	TS-PD	O	TS-PD	5 V
A5	42	O	70	A5	TS-PD	O	TS-PD	5 V
A6	43	O	70	A6	TS-PD	O	TS-PD	5 V
A7	44	O	70	A7	TS-PD	O	TS-PD	5 V
A8	45	O	70	A8	TS-PD	O	TS-PD	5 V
A9	49	O	70	A9	TS-PD	O	TS-PD	5 V
A10	50	O	70	A10	TS-PD	O	TS-PD	5 V
A11	64	O	70	A11	TS-PD	O	TS-PD	5 V
A12	65	O	70	A12	TS-PD	O	TS-PD	5 V
A13	69	O	70	A13	TS-PD	O	TS-PD	5 V
A14	70	O	70	A14	TS-PD	O	TS-PD	5 V
A15	84	O	70	A15	TS-PD	O	TS-PD	5 V
A16	85	O	70	A16	TS-PD	O	TS-PD	5 V
A17	88	O	70	A17	TS-PD	O	TS-PD	5 V
A18	89	O	70	A18	TS-PD	O	TS-PD	5 V
A19	90	O	70	A19	TS-PD	O	TS-PD	5 V
AD0	28	B	70	AD0	TS-PD	B	TS	5 V
AD1	34	B	70	AD1	TS-PD	B	TS	5 V
AD2	38	B	70	AD2	TS-PD	B	TS	5 V
AD3	46	B	70	AD3	TS-PD	B	TS	5 V
AD4	51	B	70	AD4	TS-PD	B	TS	5 V
AD5	66	B	70	AD5	TS-PD	B	TS	5 V
AD6	86	B	70	AD6	TS-PD	B	TS	5 V
AD7	92	B	70	AD7	TS-PD	B	TS	5 V
AD8	29	B	70	AD8	TS-PD	B	TS	5 V
AD9	35	B	70	AD9	TS-PD	B	TS	5 V
AD10	39	B	70	AD10	TS-PD	B	TS	5 V
AD11	47	B	70	AD11	TS-PD	B	TS	5 V
AD12	52	B	70	AD12	TS-PD	B	TS	5 V
AD13	67	B	70	AD13	TS-PD	B	TS	5 V
AD14	87	B	70	AD14	TS-PD	B	TS	5 V
AD15	93	B	70	AD15	TS-PD	B	TS	5 V
ALE [PIO33]	19	O STI-PD [STI] [O]	50	ALE	TS-PD	O	TS-PD	5 V
ARDY [PIO8]	14	STI-PU STI-PU [STI] [O]	50	ARDY	STI-PU	STI-PU	STI	5 V

Table 30. Pin List Summary (Continued)

Signal Name [Alternate Function] {Pinstrap}	Pin No.	Type	Max Load (pF)	POR Default Function	Reset State	POR Default Operation	Hold State	5 V
$\overline{\text{BHE}}$ [PIO34] {ADEN}	20	O STI-PU [STI] [O] STI	50	$\overline{\text{BHE}}$	STI-PU	O	TS-PU	5 V
$\overline{\text{BSIZE8}}$	94	O	50	$\overline{\text{BSIZE8}}$	TS-PU	O	—	—
$\overline{\text{DEN}}$ [DS] [PIO30]	18	O STI-PU [STI] [O]	50	$\overline{\text{DEN}}$	TS-PU	O	TS-PU	5 V
[DRQ0] PIO9	124	STI-PD STI-PD [STI] [O]	50	PIO9	STI-PD	STI-PD [STI] [O]	—	5 V
DRQ1	105	STI-PD	—	DRQ1	STI-PD	STI-PD	—	5 V
DT/ $\overline{\text{R}}$ [PIO29]	17	O STI-PU [STI] [O]	50	DT/ $\overline{\text{R}}$	TS-PU	O	TS-PU	5 V
HLDA {CLKSEL1}	98	O STI	50	HLDA	STI-PU	O	H	5 V
HOLD	99	STI	—	HOLD	STI-PD	STI	H	5 V
$\overline{\text{RD}}$	97	O	70	$\overline{\text{RD}}$	TS-PU	O	TS-PU	5 V
$\overline{\text{S0}}$	57	O	50	$\overline{\text{S0}}$	STI-PU	O	TS	5 V
$\overline{\text{S1}}$	56	O	50	$\overline{\text{S1}}$	TS-PU	O	TS	5 V
$\overline{\text{S2}}$	55	O	50	$\overline{\text{S2}}$	TS-PU	O	TS	5 V
S6	54	O	50	S6	TS-PD	O	TS	5 V
SRDY [PIO35]	15	STI-PU STI-PU [STI] [O]	50	SRDY	STI-PU	STI-PU	—	5 V
$\overline{\text{WHB}}$	95	O	70	$\overline{\text{WHB}}$	TS-PU	O	TS-PU	5 V
$\overline{\text{WLB}}$	96	O	70	$\overline{\text{WLB}}$	TS-PU	O	TS-PU	5 V
$\overline{\text{WR}}$ [PIO15]	16	O STI-PU [STI] [O]	50	$\overline{\text{WR}}$	STI-PU	O	TS-PU	5 V
CHIP SELECTS								
$\overline{\text{LCS}}$ [RAS0]	131	O O	50	$\overline{\text{LCS}}$	TS-PU	O	TS-PU	5 V
[MCS0] PIO4 {UCSX8}	126	O STI-PU [STI] [O] STI	50	PIO4	STI-PU	STI-PU [STI] [O]	TS-PU	5 V
$\overline{\text{MCS1}}$ [CAS1]	127	O O	50	$\overline{\text{MCS1}}$	TS-PU	O	TS-PU	5 V
$\overline{\text{MCS2}}$ [CAS0]	128	O O	50	$\overline{\text{MCS2}}$	TS-PU	O	TS-PU	5 V
[MCS3] [RAS1] PIO5	129	O O STI-PU [STI] [O]	50	PIO5	STI-PU	STI-PU [STI] [O]	TS-PU	5 V
$\overline{\text{PCS0}}$ [PIO13]	5	O STI-PU [STI] [O]	50	$\overline{\text{PCS0}}$	STI-PU	O	TS-PU	5 V
$\overline{\text{PCS1}}$ [PIO14]	6	O STI-PU [STI] [O]	50	$\overline{\text{PCS1}}$	STI-PU	O	TS-PU	5 V
$\overline{\text{PCS2}}$	7	O	50	$\overline{\text{PCS2}}$	TS-PU	O	TS-PU	5 V
$\overline{\text{PCS3}}$	8	O	50	$\overline{\text{PCS3}}$	TS-PU	O	TS-PU	5 V

Table 30. Pin List Summary (Continued)

Signal Name [Alternate Function] {Pinstrap}	Pin No.	Type	Max Load (pF)	POR Default Function	Reset State	POR Default Operation	Hold State	5 V
$\overline{\text{PCS4}}$ PIO3 {CLKSEL2}	9	O STI-PU [STI] [O] STI	50	PIO3	STI-PU	STI-PU [STI] [O]	TS-PU	5 V
$\overline{\text{PCS5}}$ PIO2	10	O STI-PU [STI] [O]	50	PIO2	STI-PU	O	TS-PU	5 V
$\overline{\text{PCS6}}$ PIO32	11	O STI-PU [STI] [O]	50	PIO32	STI-PU	STI-PU [STI] [O]	TS-PU	5 V
$\overline{\text{PCS7}}$ PIO31	13	O STI-PU [STI] [O]	50	PIO31	STI-PU	STI-PU [STI] [O]	TS-PU	5 V
$\overline{\text{UCS}}$ {ONCE}	132	O STI	50	$\overline{\text{UCS}}$	STI-PU	O	TS-PU	5 V
CLOCKS/RESET/WATCHDOG TIMER								
CLKOUT	60	O	70	CLKOUT	—	O	—	—
$\overline{\text{RES}}$	114	ST	—	$\overline{\text{RES}}$	STI	STI	—	5 V
RESOUT	58	O	50	RESOUT	H	O	—	5 V
[UCLK] PIO21	22	STI STI-PU [STI] [O]	50	PIO21	STI-PU	STI-PU [STI] [O]	—	5 V
X1	73	STI	—	X1	—	STI	—	—
X2	74	O	—	X2	—	O	—	—
PROGRAMMABLE TIMERS								
[PWD] [INT8] PIO6	147	STI STI STI-PU [STI] [O]	50	PIO6	STI-PU	STI-PU [STI] [O]	—	5 V
[TMRIN0] PIO27	142	STI-PU STI-PU [STI] [O]	50	PIO27	STI-PU	STI-PU [STI] [O]	—	5 V
[TMRIN1] PIO0	144	STI-PU STI-PU [STI] [O]	50	PIO0	STI-PU	STI-PU [STI] [O]	—	5 V
[TMROUT0] PIO28	141	O STI-PD [STI] [O]	50	PIO28	STI-PD	STI-PD [STI] [O]	TS	5 V
[TMROUT1] PIO1	143	O STI-PD [STI] [O]	50	PIO1	STI-PD	STI-PD [STI] [O]	TS	5 V
INTERRUPTS								
INT0	107	STI	—	INT0	STI-PU	STI	—	5 V
INT1	109	STI	—	INT1	STI-PU	STI	—	5 V
INT2	110	STI	—	INT2	STI-PU	STI	—	5 V
INT3	111	STI	—	INT3	STI-PU	STI	—	5 V
INT4	112	STI	—	INT4	STI-PU	STI	—	5 V
INT5	113	STI	—	INT5	STI-PU	STI	—	5 V
[INT6] PIO19	145	STI STI-PU [STI] [O]	50	PIO19	STI-PU	STI-PU [STI] [O]	—	5 V
[INT7] PIO7	146	STI STI-PU [STI] [O]	50	PIO7	STI-PU	STI-PU [STI] [O]	—	5 V
[INT8] [PWD] PIO6	147	STI STI STI-PU [STI] [O]	50	PIO6	STI-PU	STI-PU [STI] [O]	—	5 V
NMI	115	STI	—	NMI	STI-PU	STI	—	5 V

Table 30. Pin List Summary (Continued)

Signal Name [Alternate Function] {Pinstrap}	Pin No.	Type	Max Load (pF)	POR Default Function	Reset State	POR Default Operation	Hold State	5 V
HIGH-LEVEL DATA LINK CONTROL SYNCHRONOUS COMMUNICATIONS INTERFACES								
HDLC Channel A								
DCE_RXD_A [PCM_RXD_A]	118	STI STI	50	DCE_RXD_A	STI-PU	STI	—	5 V
DCE_TXD_A [PCM_TXD_A]	119	O-OD O-LS-OD	50	DCE_TXD_A	TS-PU	OD-O	—	5 V
DCE_RCLK_A [PCM_CLK_A]	117	STI STI	—	DCE_RCLK_A	STI-PU	STI	—	5 V
DCE_TCLK_A [PCM_FSC_A]	116	STI STI	—	DCE_TCLK_A	STI-PU	STI	—	5 V
[DCE_CTS_A] [PCM_TSC_A] PIO17	123	STI OD STI-PU [STI] [O]	50	PIO17	STI-PU	STI-PU [STI] [O]	—	5 V
[DCE_RTR_A] PIO18	122	O STI-PU [STI] [O]	30	PIO18	STI-PU	STI-PU [STI] [O]	—	5 V
HDLC Channel B								
[DCE_RXD_B] [PCM_RXD_B] PIO36	138	STI STI STI-PU [STI] [O]	50	PIO36	STI-PU	STI-PU [STI] [O]	—	5 V
[DCE_TXD_B] [PCM_TXD_B] PIO37	139	OD-O O-LS-OD STI-PU [STI] [O]	50	PIO37	STI-PU	STI-PU [STI] [O]	—	5 V
[DCE_RCLK_B] [PCM_CLK_B] PIO40	135	STI STI STI-PU [STI] [O]	50	PIO40	STI-PU	STI-PU [STI] [O]	—	5 V
[DCE_TCLK_B] [PCM_FSC_B] PIO41	134	STI STI STI-PU [STI] [O]	50	PIO41	STI-PU	STI-PU [STI] [O]	—	5 V
[DCE_CTS_B] [PCM_TSC_B] PIO38	137	STI OD STI-PU [STI] [O]	50	PIO38	STI-PU	STI-PU [STI] [O]	—	5 V
[DCE_RTR_B] PIO39	136	O STI-PU [STI] [O]	30	PIO39	STI-PU	STI-PU [STI] [O]	—	5 V
ASYNCHRONOUS SERIAL PORTS (UART AND HIGH-SPEED UART)								
UART								
[RXD_U] PIO26	158	STI STI-PU [STI] [O]	50	PIO26	STI-PU	STI-PU [STI] [O]	—	5 V
[TXD_U] PIO20	159	O STI-PU [STI] [O]	50	PIO20	STI-PU	STI-PU [STI] [O]	—	5 V
[CTS_U] PIO24	157	STI STI-PU [STI] [O]	50	PIO24	STI-PU	STI-PU [STI] [O]	—	5 V
[RTR_U] PIO25	156	O STI-PU [STI] [O]	30	PIO25	STI-PU	STI-PU [STI] [O]	—	5 V
HIGH-SPEED UART								
[RXD_HU] PIO16	25	STI STI-PU [STI] [O]	50	PIO16	STI-PU	STI-PU [STI] [O]	—	5 V
TXD_HU	26	O	30	TXD_HU	TS-PU	O	—	5 V

Table 30. Pin List Summary (Continued)

Signal Name [Alternate Function] {Pinstrap}	Pin No.	Type	Max Load (pF)	POR Default Function	Reset State	POR Default Operation	Hold State	5 V
[CTS_HU] PIO46	24	STI STI-PU [STI] [O]	50	PIO46	STI-PU	STI-PU [STI] [O]	—	5 V
[RTR_HU] PIO47	23	O STI-PU [STI] [O]	30	PIO47	STI-PU	STI-PU [STI] [O]	—	5 V
DEBUG SUPPORT								
QS0	62	O	30	QS0	TS-PD	O	—	5 V
QS1	63	O	30	QS1	TS-PD	O	—	5 V
SYNCHRONOUS SERIAL INTERFACE (SSI)								
[SCLK] PIO11	3	O STI-PU [STI] [O]	50	PIO11	STI-PU	STI-PU [STI] [O]	—	5 V
[SDATA] PIO12	4	O STI-PU [STI] [O]	50	PIO12	STI-PU	STI-PU [STI] [O]	—	5 V
[SDEN] PIO10	2	O STI-PD [STI] [O]	50	PIO10	STI-PD	STI-PD [STI] [O]	—	5 V
RESERVED PINS								
RSVD_104	104	—	—	—	—	—	—	—
RSVD_103	103	—	—	—	—	—	—	—
RSVD_102	102	—	—	—	—	—	—	—
RSVD_101	101	—	—	—	—	—	—	—
RSVD_81	81	—	—	—	—	—	—	—
RSVD_80	80	—	—	—	—	—	—	—
RSVD_76	76	—	—	—	—	—	—	—
RSVD_75	75	—	—	—	—	—	—	—
POWER AND GROUND								
V _{CC}	12	—	—	—	—	—	—	—
V _{CC}	27	—	—	—	—	—	—	—
V _{CC}	40	—	—	—	—	—	—	—
V _{CC}	48	—	—	—	—	—	—	—
V _{CC}	59	—	—	—	—	—	—	—
V _{CC}	68	—	—	—	—	—	—	—
V _{CC}	78	—	—	—	—	—	—	—
V _{CC}	82	—	—	—	—	—	—	—
V _{CC}	91	—	—	—	—	—	—	—
V _{CC}	106	—	—	—	—	—	—	—
V _{CC}	120	—	—	—	—	—	—	—
V _{CC}	125	—	—	—	—	—	—	—
V _{CC}	133	—	—	—	—	—	—	—
V _{CC}	148	—	—	—	—	—	—	—
V _{CC}	160	—	—	—	—	—	—	—
V _{CC}	79	—	—	—	—	—	—	—
V _{CC_A}	77	—	—	—	—	—	—	—
V _{SS}	1	—	—	—	—	—	—	—
V _{SS}	21	—	—	—	—	—	—	—

Table 30. Pin List Summary (Continued)

Signal Name [Alternate Function] {Pinstrap}	Pin No.	Type	Max Load (pF)	POR Default Function	Reset State	POR Default Operation	Hold State	5 V
V _{SS}	33	—	—	—	—	—	—	—
V _{SS}	41	—	—	—	—	—	—	—
V _{SS}	53	—	—	—	—	—	—	—
V _{SS}	61	—	—	—	—	—	—	—
V _{SS}	71	—	—	—	—	—	—	—
V _{SS}	83	—	—	—	—	—	—	—
V _{SS}	100	—	—	—	—	—	—	—
V _{SS}	108	—	—	—	—	—	—	—
V _{SS}	121	—	—	—	—	—	—	—
V _{SS}	130	—	—	—	—	—	—	—
V _{SS}	140	—	—	—	—	—	—	—
V _{SS}	155	—	—	—	—	—	—	—
V _{SS_A}	72	—	—	—	—	—	—	—

APPENDIX B—PHYSICAL DIMENSIONS: PQR160, PLASTIC QUAD FLAT PACK (PQFP)

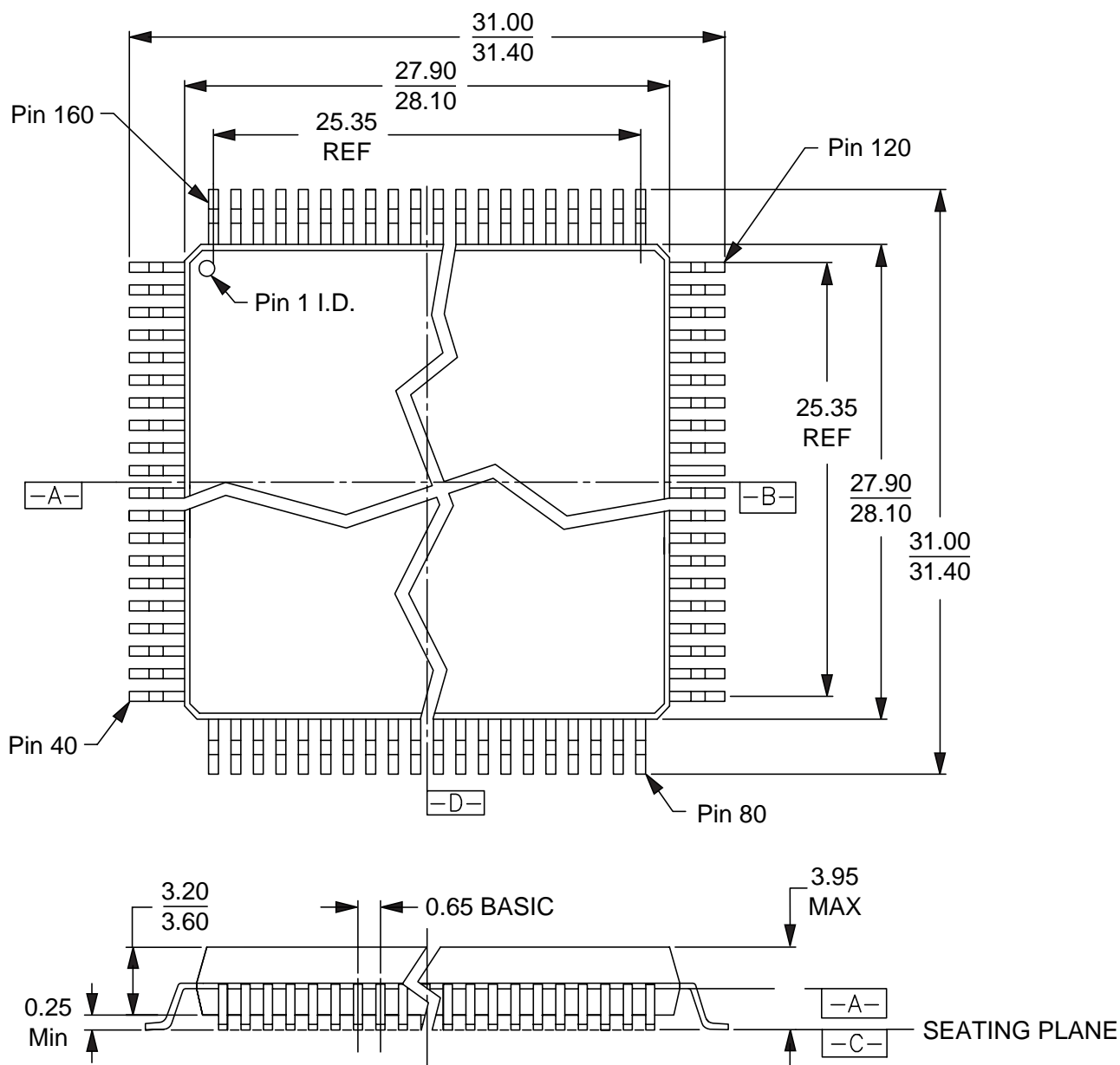

16-038-PQR-1
PQR160
12-22-95 lv

APPENDIX C—CUSTOMER SUPPORT

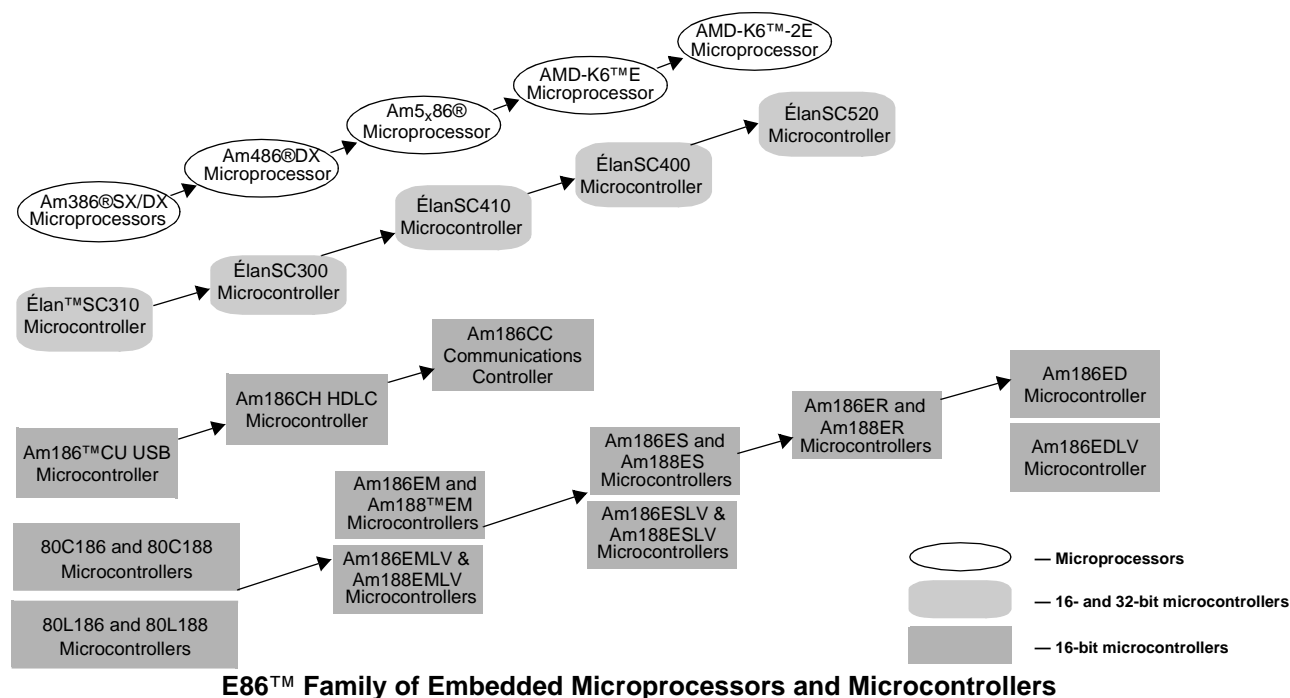

Related AMD Products—E86™ Family Devices

Device	Description
80C186/80C188	16-bit microcontroller
80L186/80L188	Low-voltage, 16-bit microcontroller
Am186™EM/Am188™EM	High-performance, 16-bit embedded microcontroller
Am186EMLV/Am188EMLV	High-performance, 16-bit embedded microcontroller
Am186ES/Am188ES	High-performance, 16-bit embedded microcontroller
Am186ESLV/Am188ESLV	High-performance, 16-bit embedded microcontroller
Am186ED	High-performance, 80C186- and 80C188-compatible, 16-bit embedded microcontroller with 8- or 16-bit external data bus
Am186EDLV	High-performance, 80C186- and 80C188-compatible, low-voltage, 16-bit embedded microcontroller with 8- or 16-bit external data bus
Am186ER/Am188ER	High-performance, low-voltage, 16-bit embedded microcontroller with 32 Kbyte of internal RAM
Am186CC	High-performance, 16-bit embedded communications controller
Am186CH	High-performance, 16-bit embedded HDLC microcontroller
Am186CU	High-performance, 16-bit embedded USB microcontroller
Élan™ SC300	High-performance, highly integrated, low-voltage, 32-bit embedded microcontroller
ÉlanSC310	High-performance, single-chip, 32-bit embedded PC/AT microcontroller
ÉlanSC400	Single-chip, low-power, PC/AT-compatible microcontroller
ÉlanSC410	Single-chip, PC/AT-compatible microcontroller
ÉlanSC520	High-performance, 32-bit embedded microcontroller
Am386@DX	High-performance, 32-bit embedded microprocessor with 32-bit external data bus
Am386@SX	High-performance, 32-bit embedded microprocessor with 16-bit external data bus
Am486@DX	High-performance, 32-bit embedded microprocessor with 32-bit external data bus
Am5x86@	High-performance, 32-bit embedded microprocessor with 32-bit external data bus
AMD-K6™E	High-performance, 32-bit embedded microprocessor with 64-bit external data bus
AMD-K6™-2E	High-performance, 32-bit embedded microprocessor with 64-bit external data bus and 3DNow!™ technology

Notes:

1. 186 = 16-bit microcontroller and 80C186-compatible (except where noted otherwise); 188 = 16-bit microcontroller with 8-bit external data bus and 80C188-compatible (except where noted otherwise); LV = low voltage

Related Documents

The following documents provide additional information regarding the Am186CH HDLC microcontroller.

- *Am186™CC/CH/CU Microcontrollers User's Manual*, order #21914
- *Am186™CC/CH/CU Microcontrollers Register Set Manual*, order #21916
- *Am186™ and Am188™ Family Instruction Set Manual*, order #21267
- *Interfacing an Am186™CC Communications Controller to an AMD SLAC™ Device Using the Enhanced SSI*, order #21921

Other information of interest includes:

- *E86™ Family Products and Development Tools CD*, order #21058

Am186CC/CH/CU Microcontroller Customer Development Platform

The Am186CC/CH/CU customer development platform (CDP) is provided as a test and development platform for the Am186CC/CH/CU microcontrollers. The Am186CC/CH/CU CDP ships with the Am186CC microcontroller. Because this device supports a superset of the features of the Am186CH HDLC microcontroller, the development platform can be used to evaluate the Am186CH device.

The CDP is divided into two major sections: a main board and a development module. The main board serves as the primary platform for silicon evaluation and software development. The board provides connectors for accessing the major communications peripherals, switches to easily configure the microcontroller, logic analyzer, and debug headers. The development module, which attaches to the top of the main board, provides ready-to-run hardware for three of the most common communications requirements:

- A 10 Mbit/s Ethernet connection
- An ISDN connection (with both an S/T and a U interface)
- Two POTS interfaces

The CDP provides a good starting point for hardware designers, and software development can begin immediately without the normal delay that occurs while waiting for prototypes.

The CDP also comes with AMD's CodeKit software that provides customers with pre-written driver software for the major communications peripherals associated with a typical Am186Cx design. Included are drivers for the HDLC channels, USB peripheral controller (for the Am186CU USB microcontroller),

UARTs, PCnet-ISA II (AMD's single-chip Ethernet solution), and several other common peripherals. The CodeKit software comes complete with instructions, royalty-free distribution rights, and software in both binary and source code formats.

Third-Party Development Support Products

The FusionE86 Program of Partnerships for Application Solutions provides the customer with an array of products designed to meet critical time-to-market needs. Products and solutions available from the AMD FusionE86 partners include protocol stacks, emulators, hardware and software debuggers, board-level products, and software development tools, among others.

In addition, mature development tools and applications for the x86 platform are widely available in the general marketplace.

Customer Service

The AMD customer service network includes U.S. offices, international offices, and a customer training center. Expert technical assistance is available from the AMD worldwide staff of field application engineers and factory support staff to answer E86 and Comm86 family hardware and software development questions.

Note: *The support telephone numbers listed below are subject to change. For current telephone numbers, refer to www.amd.com/support/literature.*

Hotline and World Wide Web Support

For answers to technical questions, AMD provides e-mail support as well as a toll-free number for direct access to our corporate applications hotline.

The AMD World Wide Web home page provides the latest product information, including technical information and data on upcoming product releases. In addition, EPD CodeKit software on the Web site provides tested source code example applications.

Corporate Applications Hotline

(800) 222-9323 Toll-free for U.S. and Canada
44-(0) 1276-803-299 U.K. and Europe hotline

Additional contact information is listed on the back of this datasheet. For technical support questions on all E86 and Comm86 products, send e-mail to epd.support@amd.com.

World Wide Web Home Page

To access the AMD home page go to: **www.amd.com**. Then follow the **Embedded Processors** link for information about E86 and Comm86 products.

Questions, requests, and input concerning AMD's WWW pages can be sent via e-mail to **webmaster@amd.com**.

Documentation and Literature

Free information such as data books, user's manuals, data sheets, application notes, the *E86™ Family Products and Development Tools CD*, order #21058, and other literature is available with a simple phone call. Internationally, contact your local AMD sales office for product literature. Additional contact information is listed on the back of this data sheet.

Literature Ordering

(800) 222-9323 Toll-free for U.S. and Canada

INDEX

A

A19–A0 signals, 13
 AD15–AD0 signals, 13
 address and data bus (AD15–AD0)
 description, 13
 address bus (A19–A0)
 address bus disable in effect, 29
 default operation, 29
 $\overline{\text{ADEN}}$ signal, A-7
 ALE signal, 13
 Am186CH HDLC microcontroller
 applications, 31
 block diagram (microcontroller), 24
 DC characteristics, 37
 distinctive characteristics, 1
 documentation, C-2
 general description, 1
 I/O circuitry, 36
 logic diagram by default pin function, 7
 logic diagram by interface, 6
 logic diagrams, 6–7
 ordering information, 2
 overview (architectural), 24
 physical dimensions, B-1
 pin assignment tables, 10
 pin connection diagram, 8
 pin tables (Appendix A), A-1
 PQFP package, B-1
 related AMD E86 family devices, C-1
 signal description table, 13
 static operation, 35
 applications, 31
 32-channel linecard system, 32
 architectural overview, 24
 ARDY signal, 13
 asynchronous communications
 asynchronous ready waveforms, 58
 asynchronous serial ports (description), 26
 baud clock, 35
 High-Speed UART clocks, 35
 High-Speed UART signal descriptions, 22
 UART signal descriptions, 21

B

$\overline{\text{BHE}}$ signal, 14
 block diagram (microcontroller), 24
 $\overline{\text{BSIZE8}}$ signal, 14
 bus
 address bus description, 13
 bus hold timing, 59
 bus status pins, 16
 entering bus hold waveforms, 59
 exiting bus hold waveforms, 60
 bus interface
 description, 30
 signal list, 13
 byte write enables, 30

C

capacitance, 38
 $\overline{\text{CAS1}}\text{--}\overline{\text{CAS0}}$ signals, 19
 characteristics
 See DC characteristics.
 switching characteristics, 40
 chip selects
 description, 30
 ranges and DRAM configuration, 13, 19
 signal descriptions, 19
 CLKOUT signal, 17
 CLKSEL1 signal, A-7
 CLKSEL2 signal, A-7
 clock
 See also CPU.
 CLKOUT signal description, 17
 clock generation and control, 33
 control, 31
 crystal parameters, 34
 crystal-driven clock source, 34
 external clock source, 35
 external interface to support clocks, 34–35
 features, 33
 High-Speed UART clocks, 35
 PLL bypass mode, 35
 suggested system clock frequencies, clock modes
 and crystal frequencies, 34
 system clock, 33
 system interfaces and clock control, 28
 UART baud clock, 35

CPU

- Am186 embedded CPU, 25
- CPU PLL modes, A-7
- system clock, 33
- system clock timing waveforms, 62
- system clocks timing, 61

crystal

- crystal-driven clock source, 34
- parameters, 34
- suggested crystal frequencies, 34

$\overline{\text{CTS_HU}}$ signal, 22

$\overline{\text{CTS_U}}$ signal, 22

customer support

- documentation and literature, C-3
- hotline and web, C-2
- literature ordering, C-3
- ordering the microcontroller, 2
- third-party development support products, C-2
- web home page, C-3

D

DC characteristics over commercial and industrial operating ranges, 37

DCE (data communications equipment)

- DCE interface timing, 65
- DCE receive waveforms, 65
- DCE transmit waveforms, 65
- signal descriptions, 22

$\overline{\text{DCE_CTS_A}}$ signal, 23

$\overline{\text{DCE_CTS_B}}$ signal, 23

$\overline{\text{DCE_RCLK_A}}$ signal, 22

$\overline{\text{DCE_RCLK_B}}$ signal, 23

$\overline{\text{DCE_RTR_A}}$ signal, 23

$\overline{\text{DCE_RTR_B}}$ signal, 23

$\overline{\text{DCE_RXD_A}}$ signal, 22

$\overline{\text{DCE_RXD_B}}$ signal, 23

$\overline{\text{DCE_TCLK_A}}$ signal, 23

$\overline{\text{DCE_TCLK_B}}$ signal, 23

$\overline{\text{DCE_TXD_A}}$ signal, 22

$\overline{\text{DCE_TXD_B}}$ signal, 23

debug

- debug support signals, 18

$\overline{\text{DEN}}$ signal, 14

derating, 38

DMA (direct memory access)

- DMA request signals, 14
- general-purpose DMA channels, 27
- SmartDMA channels, 26
- timing waveforms, 54

documentation, C-3

DRAM

- chip selects and DRAM configuration, 13
- description, 30
- read cycle with wait states waveform, 68
- read cycle without wait states waveform, 68
- refresh cycle waveform, 70
- signal descriptions, 19
- timing, 67
- write cycle with wait states waveform, 69
- write cycle without wait states waveform, 69

DRQ1–DRQ0 signals, 14

$\overline{\text{DS}}$ signal, 14

DT/ $\overline{\text{R}}$ signal, 14

E

emulation

- in-circuit emulator (ICE) support, 31
- signals used by emulators, 18

evaluation platform, C-2

H

halt

See software halt.

HDLC (high-level data link control)

- channels and TSAs description, 26
- signal descriptions, 22

High-Speed UART

- signal descriptions, 22

HLDA signal, 15

HOLD signal, 15

hotline and world wide web support, C-2

I

I/O

See also memory.

I/O circuitry, 36

I/O space, 25

programmable I/O (PIO), 27

ICE (in-circuit emulator) support, 31

INT8–INT0 signals, 20

interrupts

- interrupt controller, 27
- signal descriptions, 20

L

$\overline{\text{LCS}}$ signal, 19

logic diagram

- by default pin function, 7
- by interface, 6

M

$\overline{\text{MCS3}}\text{--}\overline{\text{MCS0}}$ signals, 19
 memory
 See also I/O.
 memory organization, 25
 segment register selection rules, 26
 memory and peripheral interface, 28
 multiplexed functions
 signal trade-offs, A-5

N

NMI signal, 20

O

$\overline{\text{ONCE}}$ signal, A-7
 operating ranges, 37
 ordering information, 2
 output enable, 30

P

package
 PQFP physical dimensions, B-1
 PCM (pulse-code modulation) highway
 signal descriptions, 23
 timing (timing slave), 62
 waveforms (timing slave), 63
 PCM_CLK_A signal, 23
 PCM_CLK_B signal, 23
 PCM_FSC_A signal, 23
 PCM_FSC_B signal, 23
 PCM_RXD_A signal, 23
 PCM_RXD_B signal, 23
 PCM_TSC_A signal, 23
 PCM_TSC_B signal, 23
 PCM_TXD_A signal, 23
 PCM_TXD_B signal, 23
 $\overline{\text{PCS7}}\text{--}\overline{\text{PCS0}}$ signals, 19
 peripherals
 memory and peripheral interface, 28
 peripheral timing, 54
 peripheral timing waveforms, 54
 system interfaces, 27

pins

See also signals.
 pin and signal tables, 9
 pin assignments sorted by pin number, 10
 pin assignments sorted by signal name, 11
 pin connection diagram, 8
 pin defaults, A-2
 pin list summary, A-11
 pin tables (Appendix A), A-1
 Multiplexed Signal Trade-Offs table, A-5
 Pin List Summary table, A-11
 PIOs Sorted by PIO Number table, A-8
 PIOs Sorted by Signal Name table, A-9
 Power-On Reset (POR) Pin Defaults table, A-2
 reserved, 18

pinstraps

 pinstraps table, A-7

PIO47–PIO0 signals, 21

PIOs (programmable I/Os)

 description, 27
 signal descriptions, 21
 sorted by pin number, A-8
 sorted by signal name, A-9

PLL (phase-locked loop)

 bypass mode, 35
 modes, A-7
 PLL bypass (CPU), A-7
 system PLL, 33

POR (power-on reset)

 pin defaults, A-2

power

 power and ground pins, 18
 power consumption calculation, 38
 power supply operation, 36
 supply connections, 36
 supply current, 38
 typical I_{CC} versus frequency, 38

PQFP package

 physical dimensions, B-1

pull-downs, in Pin List Summary table, Type column, A-11

pull-ups, in Pin List Summary table, Type column, A-11

PWD signal, 21

Q

QS1–QS0 signals, 18

R

$\overline{\text{RAS1}}\text{--}\overline{\text{RAS0}}$ signals, 19

$\overline{\text{RD}}$ signal, 15

read cycle timing, 47

read cycle waveforms, 49

ready

external ready timing, 57

external ready waveforms, 57

$\overline{\text{RES}}$ signal, 17

reserved pins, 18

reset

definition of types, 12

power-on reset pin defaults table, A-2

signals related to reset, 56

timing, 55

waveforms, 55

reset configuration pins

See pinstraps.

RESOUT signal, 17

RSVD_x–RSVD_x pins, 18

$\overline{\text{RTR_HU}}$ signal, 22

$\overline{\text{RTR_U}}$ signal, 22

RXD_HU signal, 22

RXD_U signal, 21

S

$\overline{\text{S2}}\text{--}\overline{\text{S0}}$ signals, 16

S6 signal, 16

SCLK signal, 22

SDATA signal, 22

SDEN signal, 22

serial communications

See also HDLC, UART.

asynchronous serial ports, 26

description, 26

SmartDMA, 26

synchronous serial port, 27

signals

See also pins.

multiplexed signal trade-offs table, A-5

pin and signal tables, 9

pin assignments sorted by signal name, 11

signal descriptions, 13

signals related to reset, 56

SmartDMA

See DMA.

software halt cycle timing, 53

software halt cycle waveforms, 53

SRDY signal, 16

SSI (synchronous serial interface)

signal descriptions, 22

synchronous ready waveforms, 57

synchronous serial port, 27

timing, 66

waveforms, 66

static operation, 35

switching characteristics and waveforms

alphabetical key, 41

key to switching waveforms, 40

numerical key to switching parameter symbols, 44

over commercial/industrial operating ranges, 47

parameter symbols, 41

system clock, 33

See CPU.

system interface, 28

T

thermal characteristics, 39

equations, 39

thermal resistance, 39

timers

See also watchdog timer.

programmable timers, 27

signal descriptions, 21

timing

asynchronous ready waveforms, 58

bus hold, 59

DCE interface, 65

DMA, 54

DRAM, 67

external ready cycle, 57

PCM highway, 62–63

peripheral timing, 54

read cycle timing, 47

reset, 55

software halt cycle, 53

SSI, 66

synchronous ready waveforms, 57

system clocks timing, 61

write cycle timing, 50

TMRIN1–TMRIN0 signals, 21

TMROUT1–TMROUT0 signals, 21

TSAs (time slot assigners)

description, 26

TXD_HU signal, 22

TXD_U signal, 21

U

UART

- asynchronous ready waveforms, 58
- asynchronous serial ports (description), 26
- baud clock, 35
- High-Speed UART clocks, 35
- High-Speed UART signal descriptions, 22
- signal descriptions, 21
- UART and High-Speed UART clocks, 35
- UART baud clock, 35

UCLK signal, 17

$\overline{\text{UCS}}$ signal, 19

$\overline{\text{UCSX8}}$ signal, A-7

V

V_{CC} description, 18

$V_{\text{CC_A}}$ description, 18

V_{SS} description, 18

$V_{\text{SS_A}}$ description, 18

W

watchdog timer

- description, 28

- RES and watchdog timer reset, 17

$\overline{\text{WHB}}$ signal, 16

$\overline{\text{WLB}}$ signal, 16

$\overline{\text{WR}}$ signal, 16

write cycle timing, 50

write cycle waveforms, 52

www

- home page, C-3

- support, C-2

X

X1 signal, 17

X2 signal, 17

Trademarks

© 2000 Advanced Micro Devices, Inc. All rights reserved.

AMD, the AMD logo, and combinations thereof are trademarks of Advanced Micro Devices, Inc.

Am5x86 and Am386 are registered trademarks, and AMD-K6, 3DNow!, Am186, Am188, Comm86, E86, Élan, PCnet, SLAC, and SmartDMA are trademarks of Advanced Micro Devices, Inc.

FusionE86 is a service mark of Advanced Micro Devices, Inc.

Other product names used in this publication are for identification purposes only and may be trademarks of their respective companies.

Disclaimer

The contents of this document are provided in connection with Advanced Micro Devices, Inc. ("AMD") products. AMD makes no representations or warranties with respect to the accuracy or completeness of the contents of this publication and reserves the right to make changes to specifications and product descriptions at any time without notice. No license, whether express, implied, arising by estoppel or otherwise, to any intellectual property rights is granted by this publication. Except as set forth in AMD's Standard Terms and Conditions of Sale, AMD assumes no liability whatsoever, and disclaims any express or implied warranty, relating to its products including, but not limited to, the implied warranty of merchantability, fitness for a particular purpose, or infringement of any intellectual property right.

AMD's products are not designed, intended, authorized or warranted for use as components in systems intended for surgical implant into the body, or in other applications intended to support or sustain life, or in any other application in which the failure of AMD's product could create a situation where personal injury, death, or severe property or environmental damage may occur. AMD reserves the right to discontinue or make changes to its products at any time without notice.

© 2000 Advanced Micro Devices, Inc.
All rights reserved.