



Features

- ◆ True 64-bit microprocessor
 - 64-bit integer operations
 - 64-bit floating-point operations
 - 64-bit registers
 - 64-bit virtual address space
- ◆ High-performance microprocessor
 - 260 Dhrystone MIPS at 200MHz
 - 100 peak MFLOP/s at 200MHz
 - Two-way set associative caches
 - Simple 5-stage pipeline
- ◆ High level of integration
 - 64-bit, 200 MHz integer CPU
 - 64-bit floating-point unit
 - 16KB instruction cache
 - 16KB data cache
 - Flexible MMU with large, fully associative TLB
- ◆ Low-power operation
 - 3.3V power supply, for the "RV" part
 - 5V power supply, for the "R" part
 - Dynamic power management
 - Standby mode reduces internal power
- ◆ Fully software & pin-compatible with 40xx Processor Family
- ◆ Available in 179-pin PGA or 208-pin QFP

- ◆ Available at 80-200MHz, with mode bit dependent output clock frequencies
- ◆ 64GB physical address space
- ◆ Processor family for a wide variety of embedded applications
 - LAN switches
 - Routers
 - Color printers

Description

The IDT79R4700 64-bit RISC Microprocessor is both software and pin-compatible with the R4xxx processor family. With 64-bit processing capabilities, the R4700 provides more computational power and data movement bandwidth than is delivered to typical embedded systems by 32-bit processors.

The R4700 is upwardly software compatible with the IDT79R3000™ microprocessor family, including the IDTRISController™ 79R3051™, R3052™, R3041™, R3081™ as well as the R4640™, R4650™, RC64474/475™ and R5000™. An array of development tools facilitates rapid development of R4700-based systems, allowing a variety of customers access to the MIPS Open Architecture philosophy.

Block Diagram

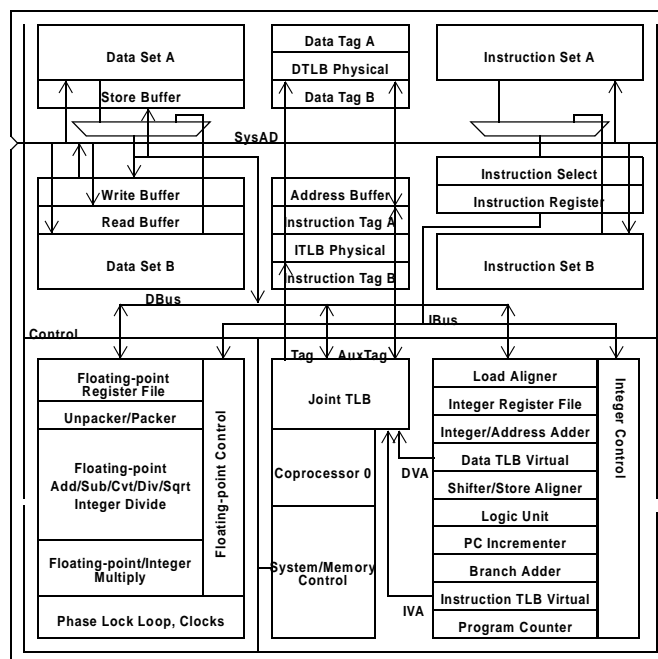

The IDT logo is a registered trademark and RC32134, RC32364, RC64145, RC64474, RC64475, RC4650, RC4640, RC4600, RC4700, RC3081, RC3052, RC3051, RC3041, RISController, and RISCore are trademarks of Integrated Device Technology, Inc.

This data sheet provides an overview of the R4700's CPU features and architecture. A more detailed description of this processor is provided in the *IDT79R4700 RISC Processor Hardware User's Manual*, available from Integrated Device Technology (IDT). Information on development support, applications notes and complementary products is available on the IDT Web site www.idt.com or through your local IDT sales representative.

Note: Throughout this data sheet and any other IDT materials for this device, the R4700 indicates a 5V part; RV4700 designates a reduced voltage (3V) part; and the RC4700 reflects either.

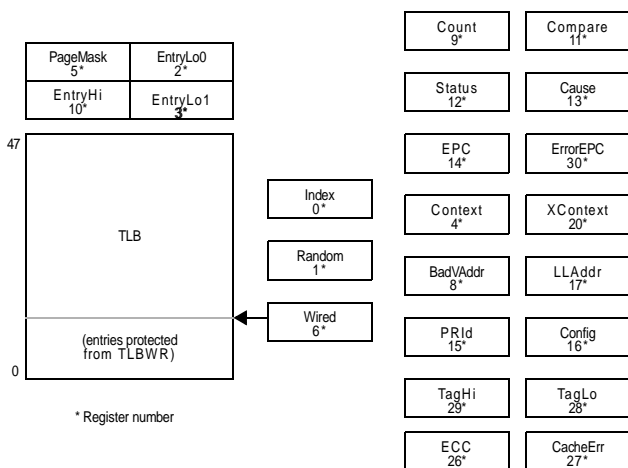

Figure 1 The RC4700 CPO Registers

Hardware Overview

The RC4700 processor family brings a high-level of integration designed for high-performance computing. The R4700's key elements are briefly described below. A more detailed explanation of each subsystem is available in the user's manual.

Pipeline

The RC4700 uses a simple 5-stage pipeline, similar to the pipeline structure implemented in the IDT79R32364. This pipeline's simplicity allows the RC4700 to be lower cost and lower power than super-scalar or super-pipelined processors. The pipeline stages are shown in Figure 3 on page 3.

Integer Execution Engine

The R4700 implements the MIPS-III Instruction Set architecture and is upwardly compatible with applications that run on earlier generation parts.

Implementation of the MIPS-III architecture results in 64-bit operations, better code density, greater multi-processing support, improved performance for commonly used code sequences in operating system kernels and faster execution of floating-point intensive applications. All

resource dependencies are made transparent to the programmer, insuring transportability among implementations of the MIPS instruction set architecture.

The MIPS integer unit implements a load/store architecture with single cycle ALU operations (logical, shift, add, sub) and an autonomous multiply/divide unit. Register resources include:

- ◆ 32 general-purpose orthogonal integer registers
- ◆ HI/LO result registers, for the integer multiply/divide unit
- ◆ Program counter

Also, the on-chip floating-point co-processor adds 32 floating-point registers and a floating-point control/status register.

Register File

The R4700 has 32 general-purpose registers (shown in Figure 2). These registers are used for scalar integer operations and address calculation. The register file consists of two read ports and one write port and is fully bypassed to minimize operation latency in the pipeline.

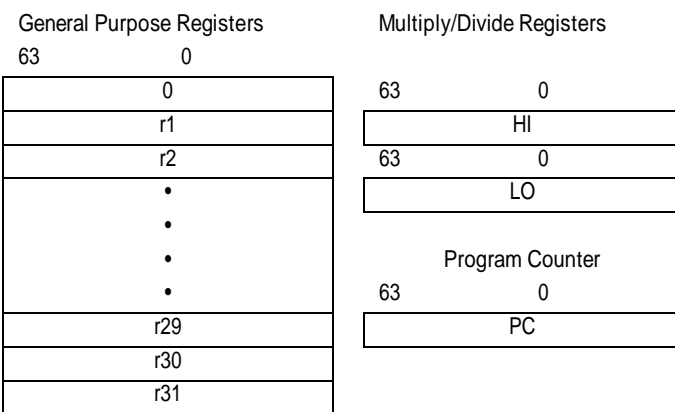

Figure 2 R4700 CPU Registers

ALU

The RC4700 ALU consists of the integer adder and logic unit. The adder performs address calculations in addition to arithmetic operations, and the logic unit performs all logical and shift operations. Each of these units is highly optimized and can perform an operation in a single pipeline cycle.

Integer Multiply/Divide

To perform integer multiply and divide operations, the RC4700 uses the floating-point unit. The results of the operation are placed in the HI and LO registers. The values can then be transferred to the general purpose register file using the MFHI/MFLO instructions. To prevent the

| | | | | | | | | | | | | | | |
|----------------|----|----|----|----|----|----|----|----|-----------|----|----|----|----|-----|
| I ₀ | 1I | 2I | 1R | 2R | 1A | 2A | 1D | 2D | 1W | 2W | | | | |
| I ₁ | | | 1I | 2I | 1R | 2R | 1A | 2A | 1D | 2D | 1W | 2W | | |
| I ₂ | | | | | 1I | 2I | 1R | 2R | 1A | 2A | 1D | 2D | 1W | ... |
| I ₃ | | | | | | | 1I | 2I | 1R | 2R | 1A | 2A | 1D | ... |
| I ₄ | | | | | | | | | 1I | 2I | 1R | 2R | 1A | ... |
| | | | | | | | | | one cycle | | | | | |

Key to Figure

- 1I-1R Instruction cache access
- 2I Instruction virtual-to-physical address translation in ITLB
- 2A-2D Data cache access and load align
- 1D Data virtual-to-physical address translation in DTLB
- 1D-2D Virtual-to-physical address translation in JTLB
- 2R Register file read
- 2R Bypass calculation
- 2R Instruction decode
- 2R Branch address calculation
- 1A Issue or slip decision
- 1A-2A Integer add, logical, shift
- 1A Data virtual address calculation
- 2A Store align
- 1A Branch decision
- 2W Register file write

Figure 3 RC4700 Pipeline Stages

occurrence of an interlock or stall, a required number of processor internal cycles must occur between an integer multiply or divide and a subsequent MFHI or MFLO operation.

| Operation | 32-bit | 64-bit |
|-----------|--------|--------|
| MULT | 6 - 9 | 7 - 10 |
| DIV | 42 | 74 |

Floating-Point Co-Processor

The RC4700 incorporates a complete floating-point co-processor on chip and includes a floating-point register file and execution units. The floating-point co-processor forms a "seamless" interface with the integer unit, decoding and executing instructions in parallel with the integer unit.

Floating-Point Units

The RC4700 floating-point execution units support single and double precision arithmetic, as specified in the IEEE Standard 754. The execution unit is separated into a multiply unit and a combined add/convert/divide/square root unit. Overlap of multiplies and add/subtract is supported. The multiplier is partially pipelined, allowing a new multiply to begin every four cycles.

The RC4700 maintains fully precise floating-point exceptions while allowing both overlapped and pipelined operations. Precise exceptions are extremely important in mission-critical environments and highly desirable for debugging in any environment.

The floating-point unit operation's set includes floating-point add, subtract, multiply, divide, square root, conversion between fixed-point and floating-point format, conversion among floating-point formats and floating-point compare. These operations comply with the IEEE Standard 754.

Table 1 lists the latencies of some of the floating-point instructions in internal processor cycles. Note that multiplies are pipelined so that a new multiply can be initiated every four pipeline cycles

Floating-Point General Register File

The floating-point register file is made up of thirty-two 64-bit registers. With the LDC1 and SDC1 instructions the floating-point unit can take advantage of the 64-bit wide data cache and issue a co-processor load or store doubleword instruction in every cycle.

The floating-point control register space contains two registers: one for determining configuration and revision information for the coprocessor and one for control and status information. These are primarily involved with diagnostic software, exception handling, state saving and restoring, and control of rounding modes.

| Operation | Single Precision | Double Precision |
|------------|------------------|------------------|
| ADD | 4 | 4 |
| SUB | 4 | 4 |
| MUL | 4 | 5 |
| DIV | 32 | 61 |
| SQRT | 31 | 60 |
| CMP | 3 | 3 |
| FIX | 4 | 4 |
| FLOAT | 6 | 6 |
| ABS | 1 | 1 |
| MOV | 1 | 1 |
| NEG | 1 | 1 |
| LWC1, LDC1 | 2 | 2 |
| SWC1, SDC1 | 1 | 1 |

Table 1 RC4700 Instruction Latencies

System Control Co-processor (CP0)

The system control co-processor in the MIPS architecture is responsible for the virtual memory sub-system, the exception control system and the diagnostics capability of the processor. In the MIPS architecture, the system control co-processor (and thus the kernel software) is implementation dependent.

System Control Co-Processor Registers

The RC4700 incorporates all system control co-processor (CP0) registers, on-chip. These registers (shown in Figure 1 on page 2) provide the path through which the virtual memory system's page mapping is examined and changed, exceptions are handled and operating modes are controlled (kernel vs. user mode, interrupts enabled or disabled, cache features). In addition, to aid in cache diagnostic testing and assist in data error detection, the RC4700 includes registers to implement a real-time cycle counting facility.

Virtual-to-Physical Address Mapping

To establish a secure environment for user processing, the RC4700 provides the user, supervisor, and kernel modes of virtual addressing, available to system software. Bits in a status register determine which virtual addressing mode is used.

While in user mode, the RC4700 provides a single, uniform virtual address space of 256GB (2GB for 32-bit address mode). When operating in the kernel mode, four distinct virtual address spaces—totalling 1024GB (4GB in 32-bit address mode)—are simultaneously available and are differentiated by the high-order bits of the virtual address.

The RC4700 processor also supports a supervisor mode in which the virtual address space is 256.5GB (2.5GB in 32-bit address mode), divided into three regions that are based on the high-order bits of the virtual address. If the RC4700 is configured for 64-bit virtual addressing, the virtual address space layout is an upwardly compatible extension of the 32-bit virtual address space layout. Figure 4 on page 5 shows the address space layout for the 32-bit virtual address operation.

Memory Management Unit (MMU)

The Memory management unit controls the virtual memory system page mapping. It consists of an instruction address translation buffer (the ITLB), a data address translation buffer (the DTLB), a Joint TLB (the JTLB), and co-processor registers used for the virtual memory mapping sub-system.

Instruction TLB (ITLB)

The RC4700 also incorporates a two-entry instruction TLB. Each entry maps a 4KB page. The instruction TLB improves performance by allowing instruction address translation to occur in parallel with data address translation. When a miss occurs on an instruction address translation, the least-recently used ITLB entry is filled from the JTLB. The operation of the ITLB is invisible to the user.

Data TLB (DTLB)

The RC4700 also incorporates a four-entry data TLB. Each entry maps a 4KB page. The data TLB improves performance by allowing data address translation to occur in parallel with instruction address translation. When a miss occurs on a data address translation, the DTLB is filled from the JTLB. The DTLB refill is pseudo-LRU: the least recently used entry of the least recently used half is filled. The operation of the DTLB is invisible to the user.

Joint TLB (JTLB)

For fast virtual-to-physical address decoding, the RC4700 uses a large, fully associative TLB that maps 96 virtual pages to their corresponding physical addresses. The TLB is organized as 48 pairs of even-odd entries and maps a virtual address and address space identifier into the large, 64GB physical address space.

Two mechanisms are provided to assist in controlling the amount of mapped space and the replacement characteristics of various memory regions. First, the page size can be configured, on a per-entry basis, to map a page size of 4KB to 16MB (in multiples of 4). A CP0 register is loaded with the page size of a mapping, and that size is entered into the TLB when a new entry is written. Thus, operating systems can provide special purpose maps; for example, a typical frame buffer can be memory mapped using only one TLB entry.

The second mechanism controls the replacement algorithm, when a TLB miss occurs. The RC4700 provides a random replacement algorithm to select a TLB entry to be written with a new mapping; however, the processor provides a mechanism whereby a system specific number

of mappings can be locked into the TLB and avoid being randomly replaced. This facilitates the design of real-time systems, by allowing deterministic access to critical software.

The joint TLB also contains information to control the cache coherency protocol for each page. Specifically, each page has attribute bits to determine whether the coherency algorithm is uncached, non-coherent write-back, non-coherent write-through write-allocate or non-coherent write-through no write-allocate. Non-coherent write-back is typically used for both code and data on the RC4700; however, hardware-based cache coherency is not supported.

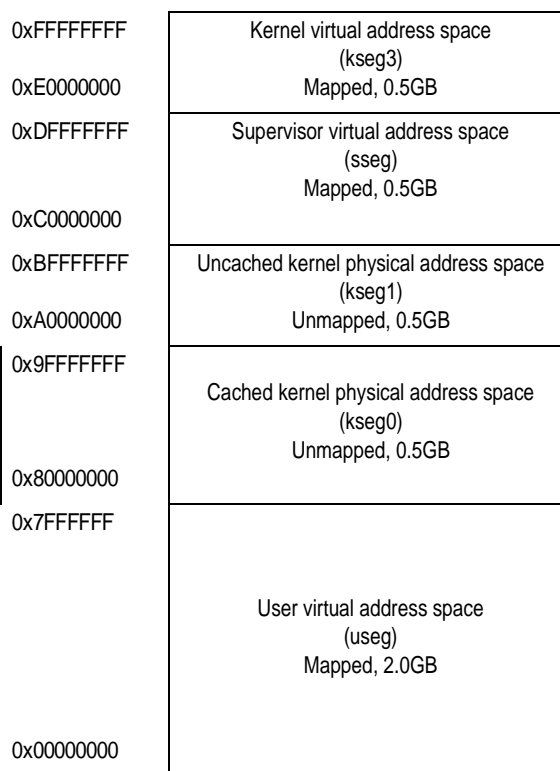

Figure 4 Kernel Mode Virtual Addressing (32-bit Mode)

Cache Memory

To keep the RC4700's high-performance pipeline full and operating efficiently, the RC4700 incorporates on-chip instruction and data caches that can be accessed in a single processor cycle. Each cache has its own 64-bit data path and can be accessed in parallel.

Instruction Cache

The RC4700 incorporates a two-way set associative on-chip instruction cache. This virtually indexed, physically tagged cache is 16KB in size and is protected with word parity.

Because the cache is virtually indexed, the virtual-to-physical address translation occurs in parallel with the cache access, further increasing performance by allowing these two operations to occur simultaneously. The tag holds a 24-bit physical address and valid bit and is parity protected.

The instruction cache is 64-bits wide and can be refilled or accessed in a single processor cycle. For a peak instruction bandwidth of 800MB/sec at 200MHz, instruction fetches require only 32 bits per cycle. To reduce power dissipation, sequential accesses take advantage of the 64-bit fetch. To minimize the cache miss penalty, cache miss refill writes use 64 bits-per-cycle, and to maximize cache performance, the line size is eight instructions (32 bytes).

Data Cache

For fast, single cycle data access, the RC4700 includes a 16KB on-chip data cache that is two-way set associative with a fixed 32-byte (eight words) line size.

The data cache is protected with byte parity and its tag is protected with a single parity bit. It is virtually indexed and physically tagged to allow simultaneous address translation and data cache access

The normal write policy is writeback, which means that a store to a cache line does not immediately cause memory to be updated. This increases system performance by reducing bus traffic and eliminating the bottleneck of waiting for each store operation to finish before issuing a subsequent memory operation. Software can however select write-through on a per-page basis when it is appropriate, such as for frame buffers.

Associated with the data cache is the store buffer. When the RC4700 executes a Store instruction, this single-entry buffer gets written with the store data while the tag comparison is performed. If the tag matches, then the data is written into the data cache in the next cycle that the data cache is not accessed (the next non-load cycle). The store buffer allows the RC4700 to execute a store instruction every processor cycle and to perform back-to-back stores without penalty.

The data cache can provide 8 bytes each clock cycle, for a peak bandwidth of 1.6 GB/sec.

Write Buffer

Writes to external memory—whether they are cache miss write-backs, stores to uncached or write-through addresses—use the on-chip write buffer. The write buffer holds a maximum of four 64-bit address and 64-bit data pairs. The entire buffer is used for a data cache writeback and allows the processor to proceed in parallel with memory updates.

System Interface

The RC4700 supports a 64-bit system interface. This interface operates from two clocks—TClock[1:0] and RClock[1:0]—provided by the RC4700, at some division of the internal clock.

The system interface consists of a 64-bit Address/Data bus with eight check bits and a 9-bit command bus protected with parity. In addition, there are eight handshake signals and six interrupt inputs. The interface has a simple timing specification and is capable of transferring data between the processor and memory at a peak rate of 500MB/sec with a 67MHz bus.

System Address/Data Bus

The 64-bit System Address Data (SysAD) bus is used to transfer addresses and data between the RC4700 and the rest of the system. It is protected with an 8-bit parity check bus, SysADC.

The system interface is configurable to allow easier interfacing to memory and I/O systems of varying frequencies. The data rate and the bus frequency at which the RC4700 transmits data to the system interface are programmable via boot time mode control bits. Also, the rate at which the processor receives data is fully controlled by the external device. Therefore, either a low cost interface requiring no read or write buffering or a faster, high performance interface can be designed to communicate with the RC4700. Again, the system designer has the flexibility to make these price/performance trade-offs.

System Command Bus

The RC4700 interface has a 9-bit System Command (SysCmd) bus. The command bus indicates whether the SysAD bus carries an address or data. If the SysAD carries an address, then the SysCmd bus also indicates what type of transaction is to take place (for example, a read or write). If the SysAD carries data, then the SysCmd bus also gives information about the data (for example, this is the last data word transmitted, or the cache state of this data line is clean exclusive). The SysCmd bus is bidirectional to support both processor requests and external requests to the RC4700. Processor requests are initiated by the RC4700 and responded to by an external device. External requests are issued by an external device and require the RC4700 to respond.

The RC4700 supports one to eight byte and block transfers on the SysAD bus. In the case of a sub-doubleword transfer, the low-order three address bits give the byte address of the transfer, and the SysCmd bus indicates the number of bytes being transferred.

Handshake Signals

There are six handshake signals on the system interface. Two of these, RdRdy* and WrRdy* are used by an external device to indicate to the RC4700 whether it can accept a new read or write transaction. The RC4700 samples these signals before deasserting the address on read and write requests.

ExtRqst* and Release* are used to transfer control of the SysAD and SysCmd buses between the processor and an external device. When an external device needs to control the interface, it asserts ExtRqst*. The RC4700 responds by asserting Release* to release the system interface to slave state.

ValidOut* and ValidIn* are used by the RC4700 and the external device respectively to indicate that there is a valid command or data on the SysAD and SysCmd buses. The RC4700 asserts ValidOut* when it is driving these buses with a valid command or data, and the external device drives ValidIn* when it has control of the buses and is driving a valid command or data.

Non-overlapping System Interface

The RC4700 bus uses a non-overlapping system interface. This means that only one processor request may be outstanding at a time and that the request must be serviced by an external device before the RC4700 issues another request. The RC4700 can issue read and write requests to an external device, and an external device can issue read and write requests to the RC4700.

For processor read transaction the RC4700 asserts ValidOut* and simultaneously drives the address and read command on the SysAD and SysCmd buses. If the system interface has RdRdy* asserted, then the processor tristates its drivers and releases the system interface to slave state by asserting Release*. The external device can then begin sending the data.

Figure 5 on page 10 shows a processor block read request and the external agent read response. The read latency is four cycles (ValidOut* to ValidIn*), and the response data pattern is DDxxDD. Figure 6 on page 10 shows a processor block write.

Write Reissue and Pipeline Write

The RC4700 implements additional write protocols that have been designed to improve performance. This implementation doubles the effective write bandwidth. The write re-issue has a high repeat rate of two cycles per write. A write issues if WrRdy* is asserted two cycles earlier and is still asserted at the issue cycle. If it is not still asserted, the last write re-issues again. Pipelined writes have the same two cycle per write repeat rate but can issue one additional write after WrRdy* de-asserts. They still follow the issue rule as R4x00 mode for other writes.

External Requests

The RC4700 responds to requests issued by an external device. The requests can take several forms. An external device may need to supply data in response to an RC4700 read request or it may need to gain control over the system interface bus to access other resources which may be on that bus. It also may issue requests to the processor, such as a request for the RC4700 to write to the RC4700 interrupt register. The RC4700 supports Write, Null, and Read Response external requests.

Boot-Time Options

Fundamental operational modes for the processor are initialized by the boot-time mode control interface. The boot-time mode control interface is a serial interface operating at a very low frequency (MasterClock divided by 256). The low-frequency operation allows the initialization

information to be kept in a low-cost serial EEPROM; alternatively, the 20-or-so bits could be generated by the system interface ASIC or a simple PAL.

Immediately after the Vccok signal is asserted, the processor reads a bit stream of 256 bits to initialize all fundamental operational modes. After initialization is complete, the processor continues to drive the serial clock output, but no further initialization bits are read.

JTAG Interface

The RC4700 supports the JTAG interface pins, with the serial input connected to serial output. Boundary scan is not supported.

Boot-Time Modes

The boot-time serial mode stream is defined in Table 3. Bit 0 is the first bit presented to the processor when Vccok is asserted; bit 255 is the last.

Power Management¹

CP0 is also used to control the power management for the RC4700. This is the standby mode and can be used to reduce the power consumption of the internal core of the CPU. Standby mode is entered by executing the WAIT instruction with the SysAD bus idle and is exited by an interrupt.

Standby Mode Operations

The RC4700 provides a means to reduce the amount of power consumed by the internal core when the CPU would otherwise not be performing any useful operations. This is known as "Standby Mode."

Entering Standby Mode

Executing the WAIT instruction enables interrupts and enters Standby mode. When the WAIT instruction finishes the W pipe-stage, if the SysAd bus is currently idle, the internal clocks will shut down, thus freezing the pipeline. The PLL, internal timer, some of the input pin clocks (Int[5:0]*, NMI*, ExtReq*, Reset*, and ColdReset*), and the output clocks—TClock[1:0], RClock[1:0] SyncOut, Modeclock and MasterOut—will continue to run. If the conditions are not correct when the WAIT instruction finishes the W pipe-stage (such as the SysAd bus is not idle), the WAIT is treated as a NOP.

Once the CPU is in Standby Mode, any interrupt—including the internally generated timer interrupt—will cause the CPU to exit Standby Mode.

¹ The R4700 implements advanced power management, to substantially reduce the average power dissipation of the device. This operation is described in the *R4700 Microprocessor Hardware User's Manual*.

Thermal Considerations

The RC4700 uses special packaging techniques to improve the thermal properties of high-speed processors. The RC4700 is packaged using cavity down packaging in a 179-pin PGA package, and a 208-lead QFP package. These packages effectively dissipate the power of the CPU, increasing device reliability.

The R4700 is guaranteed in a case temperature range of 0° to +85° C. The type of package, speed (power) of the device, and airflow conditions affect the equivalent ambient temperature conditions that will meet this specification.

The equivalent allowable ambient temperature, T_A, can be calculated using the thermal resistance from case to ambient (Θ_{CA}) of the given package. The following equation relates ambient and case temperatures:

$$T_A = T_C - P * \Theta_{CA}$$

where P is the maximum power consumption at hot temperature, calculated by using the maximum ICC specification for the device.

Typical values for Θ_{CA} at various airflows are shown in Table 2:.

| | Θ _{CA} | | | | | |
|------------------|-----------------|-----|-----|-----|-----|------|
| Airflow (ft/min) | 0 | 200 | 400 | 600 | 800 | 1000 |
| PGA | 16 | 7 | 5 | 3 | 2.5 | 2 |
| QFP | 21 | 13 | 10 | 9 | 8 | 7 |

Table 2: Thermal Resistance (Θ_{CA}) at Various Airflows

Revision History

Revision History

January 1996: Initial draft.

March 1997: Deleted data on 150MHz speed for 5V part only.

August 1997: Upgraded 80 to 175 MHz speed specs from "Preliminary" to "Final."

June 1999: Upgraded speed to 200MHz on 3V part specs. Package change to DP.

June 29, 2000: Added back 175 and 200 MHz speeds.

April 10, 2001: In the Data Output category of the System Interface Parameters tables, changed values in the Min column for all speeds from 1.0 to 0.

| Mode bit | Description | Mode bit | Description |
|----------|--------------------------------------------------------------------------------------------------------------------------------------------------------------------|----------|------------------------------------------------------------------------------------------------------------------------------------|
| 0 | reserved (must be zero) | 14:13 | Output driver strength 10 → 100% strength (fastest), 11 → 83% strength, 00 → 67% strength, 01 → 50% strength (slowest) |
| 4:1 | Writeback data rate 0 → Δ, 1 → DDx, 2 → DDxx, 3 → Dx Dx, 4 → DDxxx, 5 → DDxxxx, 6 → DxxDxx, 7 → DDxxxxxx, 8 → DxxxDxxx, 9 → reserved | bit 15 | 0 → TClock[0] enabled 1 → TClock[0] disabled |
| 7:5 | Clock divisor 0 → 2, 1 → 3, 2 → 4, 3 → 5, 4 → 6, 5 → 7, 6 → 8, 7 reserved | bit 16 | 0 → TClock[1] enabled 1 → TClock[1] disabled |
| 8 | 0 → Little endian, 1 → Big endian | bit 17 | 0 → RClock[0] enabled 1 → RClock[0] disabled |
| 10:9 | 00 → R4000 compatible, 01 → reserved, 10 → pipelined writes, 11 → write re-issue | bit 18 | 0 → RClock[1] enabled 1 → RClock[1] disabled |
| 11 | Disable the timer interrupt on Int[5]. 0 → Enabled 1 → Disabled | 255:19 | Reserved (must be zero) |
| 12 | reserved (must be zero) | | |

Table 3 Boot-time Serial Mode Stream

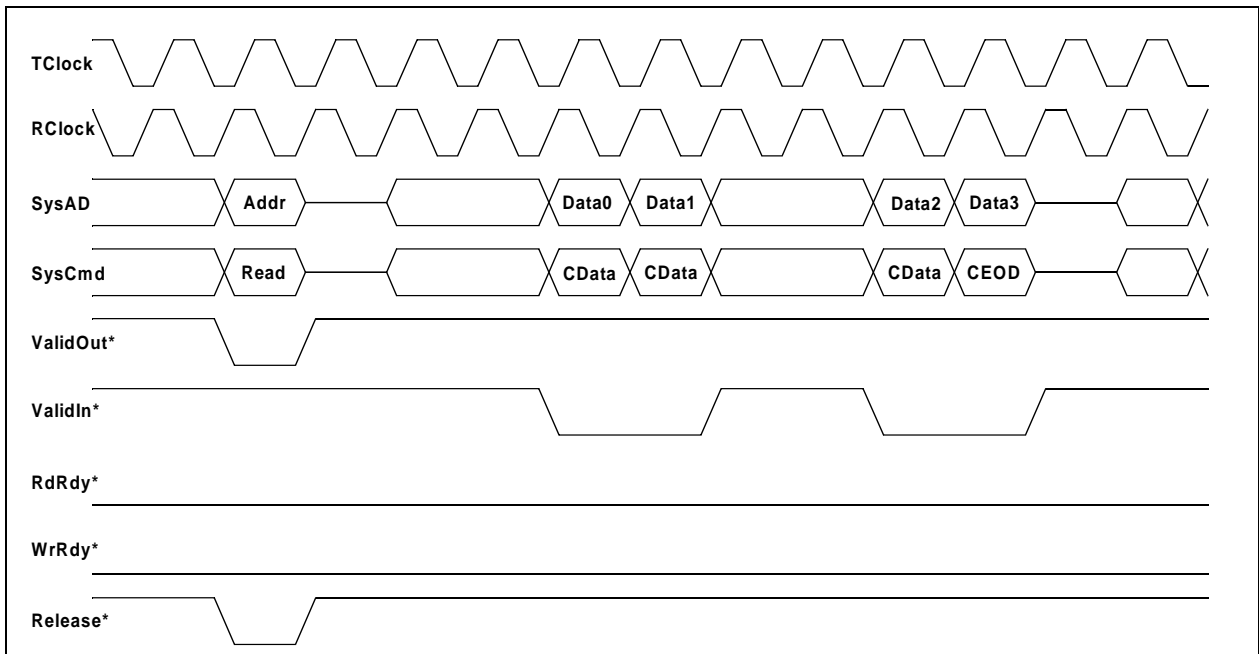

Figure 5 Processor Block Read

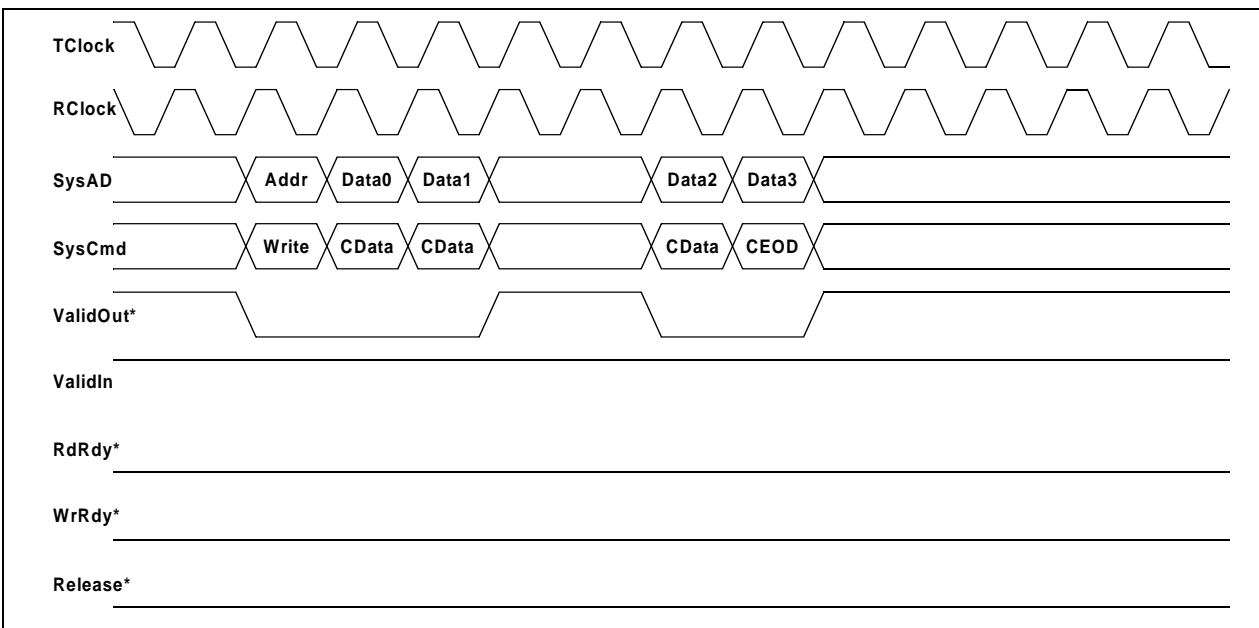

Figure 6 Processor Block Write

Pin Description

The table below provides a list of interface, interrupt and miscellaneous pins that are available on the RC4700. Note that signals marked with an asterisk are active when low. Boundary scan is not supported.

| Pin Name | Type | Description |
|-------------------------|------|--------------------------------------------------------------------------------------------------------------------------------------------------------------------------|
| System Interface | | |
| ExtRqst* | I | External request Signals that the system interface needs to submit an external request. |
| Release* | O | Release interface Signals that the processor is releasing the system interface to slave state. |
| RdRdy* | I | Read Ready Signals that an external agent can now accept a processor read. |
| WrRdy* | I | Write Ready Signals that an external agent can now accept a processor write request. |
| ValidIn* | I | Valid Input Signals that an external agent is now driving a valid address or data on the SysAD bus and a valid command or data identifier on the SysCmd bus. |
| ValidOut* | O | Valid output Signals that the processor is now driving a valid address or data on the SysAD bus and a valid command or data identifier on the SysCmd bus. |
| SysAD(63:0) | I/O | System address/data bus A 64-bit address and data bus for communication between the processor and an external agent. |
| SysADC(7:0) | I/O | System address/data check bus An 8-bit bus containing parity check bits for the SysAD bus during data bus cycles. |
| SysCmd(8:0) | I/O | System command/data identifier bus A 9-bit bus for command and data identifier transmission between the processor and an external agent. |
| SysCmdP | I/O | Reserved system command/data identifier bus parity for the R4700 unused on input and zero on output. |
| Clock/Control Interface | | |
| MasterClock | I | Master clock Master clock input at one half the processor operating frequency. |
| MasterOut | O | Master clock out Master clock output aligned with MasterClock. |
| RClock(1:0) | O | Receive clocks Two identical receive clocks at the system interface frequency. |
| TClock(1:0) | O | Transmit clocks Two identical transmit clocks at the system interface frequency. |
| IOOut | O | Reserved for future output Always HIGH. |
| IOIn | I | Reserved for future input Should be driven HIGH. |
| SyncOut | O | Synchronization clock out Must be connected to SyncIn through an interconnect that models the interconnect between MasterOut, TClock, RClock, and the external agent. |
| SyncIn | I | Synchronization clock in Synchronization clock input. See SyncOut. |
| Fault* | O | Fault Always HIGH. |

| Pin Name | Type | Description |
|----------|------|--------------------------------------------------------------------|
| VccP | I | Quiet Vcc for PLL Quiet Vcc for the internal phase locked loop. |
| VssP | I | Quiet Vss for PLL Quiet Vss for the internal phase locked loop. |

Interrupt Interface

| | | |
|-----------|---|-------------------------------------------------------------------------------------------------------|
| Int*(5:0) | I | Interrupt Six general processor interrupts, bit-wise ORed with bits 5:0 of the interrupt register. |
| NMI* | I | Non-maskable interrupt Non-maskable interrupt, ORed with bit 6 of the interrupt register. |

Initialization Interface

| | | |
|------------|---|----------------------------------------------------------------------------------------------------------------------------------------------------------------------------------------------------------------------------------------------------------------------|
| Vccok | I | Vcc is OK When asserted, this signal indicates to the R4700 that the power supply has been above the Vcc minimum for more than 100 milliseconds and will remain stable. The assertion of Vccok initiates the reading of the boot-time-mode-control serial stream. |
| ColdReset* | I | Cold reset This signal must be asserted for a power on reset or a cold reset. The clocks SClock, TClock, and RClock begin to cycle and are synchronized with the de-assertion edge of ColdReset. ColdReset must be de-asserted synchronously with MasterOut. |
| Reset* | I | Reset This signal must be asserted for any reset sequence. It may be asserted synchronously or asynchronously for a cold reset, or synchronously to initiate a warm reset. Reset must be de-asserted synchronously with MasterOut. |
| ModeClock | O | Boot-mode clock Serial boot-mode data clock output at the system clock frequency divided by two hundred fifty-six. |
| Modeln | I | Boot-mode data in Serial boot-mode data input. |

Absolute Maximum Ratings

Note: Stresses greater than those listed under ABSOLUTE MAXIMUM RATINGS may cause permanent damage to the device. This is a stress rating only, and functional operation of the device at these or any other conditions above those indicated in the operational sections of this specification is not implied. Exposure to absolute maximum rating conditions for extended periods may affect reliability.

| Symbol | Rating | RV4700 3.3V±5% | R4700 5.0V±5% | Unit |
|-------------------|--------------------------------------|---------------------------|---------------------------|------|
| | | Commercial | Commercial | |
| V _{TERM} | Terminal Voltage with respect to GND | -0.5 ¹ to +4.6 | -0.5 ¹ to +7.0 | V |
| T _C | Operating Temperature (case) | 0 to +85 | 0 to +85 | °C |
| T _{BIAS} | Case Temperature Under Bias | -55 to +125 | -55 to +125 | °C |
| T _{STG} | Storage Temperature | -55 to +125 | -55 to +125 | °C |
| I _{IN} | DC Input Current | 20 ² | 20 ² | mA |
| I _{OUT} | DC Output Current | 50 | 50 ³ | mA |

¹. V_{IN} minimum = -2.0V for pulse width less than 15ns. V_{IN} should not exceed V_{CC} +0.5V.

². When V_{IN} < 0.0V or V_{IN} > V_{CC}.

³. Not more than one output should be shorted at a time. Duration of the short should not exceed 30 seconds.

Recommended Operation Temperature and Supply Voltage

| Grade | Temperature | GND | RV4700 | R4700 |
|------------|---------------------|-----|-----------------|-----------------|
| | | | V _{CC} | V _{CC} |
| Commercial | 0°C to +85°C (Case) | 0V | 3.3V±5% | 5.0V±5% |

DC Electrical Characteristics—R4700

(V_{CC} = 5.0±5%, T_{CASE} = 0°C to +85°C)

| Parameter | R4700 80 MHz | | R4700 100MHz | | R4700 133MHz | | Conditions |
|---------------------|------------------------|------------------------|------------------------|------------------------|------------------------|------------------------|---------------------------------------|
| | Min | Max | Min | Max | Min | Max | |
| V _{OL} | — | 0.1V | — | 0.1V | — | 0.1V | I _{OUT} = 20uA |
| V _{OH} | V _{CC} - 0.1V | — | V _{CC} - 0.1V | — | V _{CC} - 0.1V | — | |
| V _{OL} | — | 0.4V | — | 0.4V | — | 0.4V | I _{OUT} = 4mA |
| V _{OH} | 3.5V | — | 3.5V | — | 3.5V | — | |
| V _{IL} | -0.5V | 0.8V | -0.5V | 0.8V | -0.5V | 0.8V | — |
| V _{IH} | 2.0V | V _{CC} + 0.5V | 2.0V | V _{CC} + 0.5V | 2.0V | V _{CC} + 0.5V | — |
| I _{IN} | — | ±10uA | — | ±10uA | — | ±10uA | 0 ≤ V _{IN} ≤ V _{CC} |
| C _{IN} | — | 15pF | — | 15pF | — | 15pF | — |
| C _{OUT} | — | 15pF | — | 15pF | — | 15pF | — |
| I/O _{LEAK} | — | 20uA | — | 20uA | — | 20uA | Input/Output Leakage |

Power Consumption—R4700

| Parameter | R4700 80 MHz | | R4700 100MHz | | R4700 133MHz | | Conditions | |
|-------------------|--------------------|---------------------|----------------------|---------------------|----------------------|---------------------|--------------------------------------------------------------------------------------|---------------------------------------------------------------------------|
| | Typical | Max | Typical ¹ | Max | Typical ¹ | Max | | |
| System Condition: | 80/20 MHz | | 100/25MHz | | 133/33MHz | | — | |
| I _{CC} | standby | — | 150mA ² | — | 175mA ² | — | 225mA ² | C _L = 0pF ³ |
| | | — | 215mA ² | — | 250mA ² | — | 325mA ² | C _L = 50pF |
| | active | 750mA ² | 850 mA ² | 875mA ² | 1000mA ² | 1175mA ² | 1300mA ² | C _L = 0pF No SysAd activity ³ |
| | | 850mA ² | 1050mA ² | 975mA ² | 1200mA ² | 1275mA ² | 1500mA ² | C _L = 50pF R4x00 compatible writes T _C = 25°C |
| | 850mA ² | 1250mA ^a | 975mA ² | 1400mA ⁴ | 1275mA ² | 1675mA ⁴ | C _L = 50pF Pipelined writes or write re-issue T _C = 25°C | |

¹ Typical integer instruction mix and cache miss rates.

² These are not tested. They are the result of engineering analysis and are provided for reference only.

³ Guaranteed by design.

⁴ These are the specifications IDT tests to insure compliance.

AC Electrical Characteristics—R4700

 $(V_{CC}=5.0V \pm 5\%; T_{CASE} = 0^{\circ}C \text{ to } +85^{\circ}C)$

Clock Parameters—R4700

| Parameter | Symbol | Test Conditions | R4700 80MHz | | R4700 100MHz | | R4700 133MHz | | Units |
|-----------------------------------------------------|-------------------|------------------------------|----------------|---------------------|-----------------|---------------------|-----------------|---------------------|-------|
| | | | Min | Max | Min | Max | Min | Max | |
| MasterClock HIGH | t_{MCHIGH} | Transition $\leq t_{MCRise}$ | 4 | — | 4 | — | 3 | — | ns |
| MasterClock LOW | t_{MCLow} | Transition $\leq t_{MCFall}$ | 4 | — | 4 | — | 3 | — | ns |
| MasterClock Frequency ¹ | — | — | 25 | 40 | 25 | 50 | 25 | 67 | MHz |
| MasterClock Period | t_{MCP} | — | 25 | 40 | 20 | 40 | 15 | 40 | ns |
| Clock Jitter for MasterClock | $t_{JitterIn}^2$ | — | — | ± 250 | — | ± 250 | — | ± 250 | ps |
| Clock Jitter for MasterOut, SyncOut, TClock, RClock | $t_{JitterOut}^2$ | — | — | ± 500 | — | ± 500 | — | ± 500 | ps |
| MasterClock Rise Time | t_{MCRise}^2 | — | — | 5.5 | — | 5 | — | 4 | ns |
| MasterClock Fall Time | t_{MCFall}^2 | — | — | 5.5 | — | 5 | — | 4 | ns |
| ModeClock Period | $t_{ModeCKP}^2$ | — | — | $256 \cdot t_{MCP}$ | — | $256 \cdot t_{MCP}$ | — | $256 \cdot t_{MCP}$ | ns |
| JTAG Clock Period | $t_{JTAGCKP}^2$ | — | — | $4 \cdot t_{MCP}$ | — | $4 \cdot t_{MCP}$ | — | $4 \cdot t_{MCP}$ | ns |
| SyncOut to SyncIn Delay | $t_{Sync}^{2,3}$ | — | — | $2 \cdot t_{MCP}$ | — | $2 \cdot t_{MCP}$ | — | $2 \cdot t_{MCP}$ | ns |

¹ Operation of the R4700 is only guaranteed with the Phase Lock Loop enabled.² Guaranteed by design.³ Rise and fall times of the SyncIn signal must match those of MasterClock to avoid the introduction of additional clock skew.

System Interface Parameters—R4700

Note: Timings are measured from 1.5V of the clock to 1.5V of the signal.

| Parameter | Symbol | Test Conditions | R4700 80MHz | | R4700 100MHz | | R4700 133MHz | | Units |
|------------------|----------|---------------------------------------|----------------|-----|-----------------|-----|-----------------|-----|-------|
| | | | Min | Max | Min | Max | Min | Max | |
| Data Output | t_{DO} | mode _{14..13} = 10 (fastest) | 0 ¹ | 9 | 0 ¹ | 9 | 0 ¹ | 9 | ns |
| | | mode _{14..13} = 01 (slowest) | 0 ¹ | 15 | 0 ¹ | 15 | 0 ¹ | 12 | ns |
| Input Data Setup | t_{DS} | $t_{rise} = 5ns$ | 3.5 | — | 3.5 | — | 3.5 | — | ns |
| Input Data Hold | t_{DH} | $t_{fall} = 5ns$ | 1.5 | — | 1.5 | — | 1.5 | — | ns |

¹ Guaranteed by design.

Boot-Time Interface Parameters—R4700

| Parameter | Symbol | Test Conditions | R4700 80MHz | | R4700 100MHz | | R4700 133MHz | | Units |
|-----------------|----------|-----------------|----------------|-----|-----------------|-----|-----------------|-----|-------------------|
| | | | Min | Max | Min | Max | Min | Max | |
| Mode Data Setup | t_{DS} | — | 3 | — | 3 | — | 3 | — | Master ClockCycle |
| Mode Data Hold | t_{DH} | — | 0 | — | 0 | — | 0 | — | Master ClockCycle |

Capacitive Load Deration—R4700

| Parameter | Symbol | R4700 80MHz | | R4700 100MHz | | R4700 133MHz | | Units |
|-------------|-----------------|-------------|-----|--------------|-----|--------------|-----|---------|
| | | Min | Max | Min | Max | Min | Max | |
| Load Derate | C _{LD} | — | 2 | — | 2 | — | 2 | ns/25pF |

AC Electrical Characteristics — RV4700

(V_{CC}=3.3V ± 5%; T_{CASE} = 0°C to +85°C)

Clock Parameters

| Parameter | Symbol | Test Conditions | RV4700 100MHz | | RV4700 133MHz | | RV4700 150MHz | | Units |
|-----------------------------------------------------|-------------------------------------|---------------------------------------|---------------|----------------------|---------------|----------------------|---------------|----------------------|-------|
| | | | Min | Max | Min | Max | Min | Max | |
| MasterClock HIGH | t _{MCHIGH} | Transition ≤ t _{MCRise/Fall} | 4 | — | 3 | — | 3 | — | ns |
| MasterClock LOW | t _{MCLOW} | Transition ≤ t _{MCRise/Fall} | 4 | — | 3 | — | 3 | — | ns |
| MasterClock Frequency ¹ | — | — | 25 | 50 | 25 | 67 | 25 | 75 | MHz |
| MasterClock Period | t _{MCP} | — | 20 | 40 | 15 | 40 | 13.3 | 40 | ns |
| Clock Jitter for MasterClock | t _{JitterIn} ² | — | — | ±250 | — | ±250 | — | ±250 | ps |
| Clock Jitter for MasterOut, SyncOut, TClock, RClock | t _{JitterOut} ² | — | — | ±500 | — | ±500 | — | ±500 | ps |
| MasterClock Rise Time | t _{MCRise} ² | — | — | 5 | — | 4 | — | 3.5 | ns |
| MasterClock Fall Time | t _{MCFall} ² | — | — | 5 | — | 4 | — | 3.5 | ns |
| ModeClock Period | t _{ModeCKP} | — | — | 256*t _{MCP} | — | 256*t _{MCP} | — | 256*t _{MCP} | ns |
| SyncOut to SyncIn Delay | t _{Sync} ^{2,3} | — | — | 2*t _{MCP} | — | 2*t _{MCP} | — | 2*t _{MCP} | ns |

¹ Typical integer instruction mix and cache miss rates.² Guaranteed by Design.³ Rise and fall times of the SyncIn signal must match those of MasterClock to avoid the introduction of additional clock skew.

| Parameter | Symbol | Test Conditions | RV4700 175MHz ¹ | | RV4700 200MHz ¹ | | Units |
|-----------------------------------------------------|------------------------------------|---------------------------------------|----------------------------|----------------------|----------------------------|----------------------|-------|
| | | | Min | Max | Min | Max | |
| MasterClock HIGH | t _{MCHIGH} | Transition ≤ t _{MCRise/Fall} | 3 | — | 3 | — | ns |
| MasterClock LOW | t _{MCLOW} | Transition ≤ t _{MCRise/Fall} | 3 | — | 3 | — | ns |
| MasterClock Frequency ² | — | — | 25 | 87.5 | 25 | 100 | MHz |
| MasterClock Period | t _{MCP} | — | 11.4 | 40 | 10 | 40 | ns |
| Clock Jitter for MasterClock | t _{JitterIn} ³ | — | — | ±250 | — | ±250 | ps |
| Clock Jitter for MasterOut, SyncOut, TClock, RClock | t _{JitterOu} ³ | — | — | ±500 | — | ±500 | ps |
| MasterClock Rise Time | t _{MCRise} ³ | — | — | 3.5 | — | 3.5 | ns |
| MasterClock Fall Time | t _{MCFall} ³ | — | — | 3.5 | — | 3.5 | ns |
| ModeClock Period | t _{ModeCKP} | — | — | 256*t _{MCP} | — | 256*t _{MCP} | ns |
| SyncOut to SyncIn Delay | t _{Sync} ^{3,4} | — | — | 2*t _{MCP} | — | 2*t _{MCP} | — |

¹ Operation of the R4700 is only guaranteed with the Phase Lock Loop enabled.² Typical integer instruction mix and cache miss rates.³ Guaranteed by design.⁴ Rise and fall times of the SyncIn signal must match those of MasterClock to avoid the introduction of additional clock skew.

DC Electrical Characteristics—RV4700

(V_{CC} = 3.3±5%, T_{CASE} = 0°C to +85°C)

| Parameter | RV4700 100MHz | | RV4700 133MHz | | Conditions |
|---------------------|------------------------|------------------------|------------------------|------------------------|---------------------------------------|
| | Min | Max | Min | Max | |
| V _{OL} | — | 0.1V | — | 0.1V | I _{OUT} = 20uA |
| V _{OH} | V _{CC} - 0.1V | — | V _{CC} - 0.1V | — | |
| V _{OL} | — | 0.4V | — | 0.4V | I _{OUT} = 4mA |
| V _{OH} | 2.4V | — | 2.4V | — | |
| V _{IL} | -0.5V | 0.2V _{CC} | -0.5V | 0.2V _{CC} | — |
| V _{IH} | 0.7V _{CC} | V _{CC} + 0.5V | 0.7V _{CC} | V _{CC} + 0.5V | — |
| I _{IN} | — | ±10uA | — | ±10uA | 0 ≤ V _{IN} ≤ V _{CC} |
| C _{IN} | — | 15pF | — | 15pF | — |
| C _{OUT} | — | 15pF | — | 15pF | — |
| I/O _{LEAK} | — | 20uA | — | 20uA | Input/Output Leakage |

| Parameter | RV4700 150MHz | | RV4700 175MHz | | RV4700 200MHz | | Conditions |
|---------------------|------------------------|------------------------|------------------------|------------------------|------------------------|------------------------|---------------------------------------|
| | Min | Max | Min | Max | Min | Max | |
| V _{OL} | — | 0.1V | — | 0.1V | — | 0.1V | I _{OUT} = 20uA |
| V _{OH} | V _{CC} - 0.1V | — | V _{CC} - 0.1V | — | V _{CC} - 0.1V | — | |
| V _{OL} | — | 0.4V | — | 0.4V | — | 0.4V | I _{OUT} = 4mA |
| V _{OH} | 2.4V | — | 2.4V | — | 2.4V | — | |
| V _{IL} | -0.5V | 0.2V _{CC} | -0.5V | 0.2V _{CC} | -0.5V | 0.2V _{CC} | — |
| V _{IH} | 0.7V _{CC} | V _{CC} + 0.5V | 0.7V _{CC} | V _{CC} + 0.5V | 0.7V _{CC} | V _{CC} + 0.5V | — |
| I _{IN} | — | ±10uA | — | ±10uA | — | ±10uA | 0 ≤ V _{IN} ≤ V _{CC} |
| C _{IN} | — | 15pF | — | 15pF | — | 15pF | — |
| C _{OUT} | — | 15pF | — | 15pF | — | 15pF | — |
| I/O _{LEAK} | — | 20uA | — | 20uA | — | 20uA | Input/Output Leakage |

System Interface Parameters—RV4700

Note: Operation of the R4700 is only guaranteed with the Phase Lock Loop enabled.

| Parameter | Symbol | Test Conditions | RV4700 100MHz | | RV4700 133MHz | | RV4700 150MHz | | Units |
|--------------------------|------------------------------------------------|----------------------------------------------------|---------------|-----|---------------|-----|---------------|-----|-------|
| | | | Min | Max | Min | Max | Min | Max | |
| Data Output ¹ | $t_{DM} = \text{Min}$ $t_{DO} = \text{Max}$ | mode _{14..13} = 10 (fastest) | 0 | 9 | 0 | 9 | 0 | 8 | ns |
| | | mode _{14..13} = 01 (slowest) | 0 | 15 | 0 | 12 | 0 | 12 | ns |
| Input Data Setup | t_{DS} | $t_{rise} = 3\text{ns}$ $t_{fall} = 3\text{ns}$ | 3.5 | — | 3.5 | — | 3.5 | — | ns |
| Input Data Hold | t_{DH} | | 1.5 | — | 1.5 | — | 1.5 | — | ns |

¹. Timings are measured from 1.5V of the clock to 1.5V of the signal.

| Parameter | Symbol | Test Conditions | RV4700 175MHz | | RV4700 200MHz | | Units |
|--------------------------|------------------------------------------------|----------------------------------------------------|---------------|-----|---------------|-----|-------|
| | | | Min | Max | Min | Max | |
| Data Output ¹ | $t_{DM} = \text{Min}$ $t_{DO} = \text{Max}$ | mode _{14..13} = 10 (fastest) | 0 | 8 | 0 | 8 | ns |
| | | mode _{14..13} = 01 (slowest) | 0 | 12 | 0 | 12 | ns |
| Input Data Setup | t_{DS} | $t_{rise} = 3\text{ns}$ $t_{fall} = 3\text{ns}$ | 3.5 | — | 3.5 | — | ns |
| Input Data Hold | t_{DH} | | 1.5 | — | 1.5 | — | ns |

¹. Capacitive load for all output timings is 50pF.

Boot-Time Interface Parameters—RV4700

| Parameter | Symbol | Test Conditions | RV4700 100MHz | | RV4700 133MHz | | RV4700 150MHz | | Units |
|-----------------|----------|-----------------|---------------|-----|---------------|-----|---------------|-----|--------------------|
| | | | Min | Max | Min | Max | Min | Max | |
| Mode Data Setup | t_{DS} | — | 3 | — | 3 | — | 3 | — | Master Clock Cycle |
| Mode Data Hold | t_{DH} | — | 0 | — | 0 | — | 0 | — | Master Clock Cycle |

| Parameter | Symbol | Test Conditions | RV4700 175MHz | | RV4700 200MHz | | Units |
|-----------------|----------|-----------------|---------------|-----|---------------|-----|--------------------|
| | | | Min | Max | Min | Max | |
| Mode Data Setup | t_{DS} | — | 3 | — | 3 | — | Master Clock Cycle |
| Mode Data Hold | t_{DH} | — | 0 | — | 0 | — | Master Clock Cycle |

Power Consumption—RV4700

| Parameter | | RV4700 100MHz | | RV4700 133MHz | | RV4700 150MHz | | Conditions |
|------------------|---------|----------------------|---------------------|----------------------|---------------------|----------------------|---------------------|-----------------------------------------------------------------------------------|
| | | Typical ¹ | Max | Typical ¹ | Max | Typical ¹ | Max | |
| System Condition | | 100/25MHz | | 133/33MHz | | 150/38MHz | | — |
| I _{CC} | standby | — | 125mA ² | — | 175mA ² | — | 200mA ² | C _L = 0pF ³ |
| | | — | 175mA ² | — | 225mA ² | — | 250mA ² | C _L = 50pF |
| | active | 575mA ² | 875mA ² | 775mA ² | 1150mA ² | 875mA ² | 1300mA ² | C _L = 0pF, No SysAd activity ³ |
| | | 650mA ² | 1100mA ² | 850mA ² | 1375mA ² | 950mA ² | 1550mA ² | C _L = 50pF R4x00 compatible writes, T _C = 25°C ³ |
| | | 650mA ² | 1275mA ⁴ | 850mA ² | 1525mA ⁴ | 950mA ² | 1725mA ² | C _L = 50pF Pipelined writes or write re-issue, T _C = 25°C |

¹. Typical integer instruction mix and cache miss rates.

². These are not tested. They are the result of engineering analysis and are provided for reference only.

³. Guaranteed by design.

⁴. These are the specifications IDT tests to insure compliance.

| Parameter | | RV4700 175MHz | | RV4700 200MHz | | Conditions |
|------------------|---------|----------------------|---------------------|----------------------|---------------------|-----------------------------------------------------------------------------------|
| | | Typical ¹ | Max | Typical ¹ | Max | |
| System Condition | | 175/44MHz | | 200/50MHz | | — |
| I _{CC} | standby | — | 200mA ² | — | 200mA ² | C _L = 0pF ³ |
| | | — | 250mA ² | — | 250mA ² | C _L = 50pF |
| | active | 1025mA ² | 1500mA ² | 1025mA ² | 1500mA ² | C _L = 0pF, No SysAd activity ³ |
| | | 1200mA ² | 1800mA ² | 1200mA ² | 1800mA ² | C _L = 50pF R4x00 compatible writes, T _C = 25°C ³ |
| | | 1200mA ² | 2000mA ⁴ | 1200mA ² | 2000mA ⁴ | C _L = 50pF Pipelined writes or write re-issue, T _C = 25°C |

¹. Typical integer instruction mix and cache miss rates.

². These are not tested. They are the result of engineering analysis and are provided for reference only.

³. Guaranteed by design.

⁴. These are the specifications IDT tests to insure compliance.

RC4700 QFP Package Pin-Out

Note: N.C. pins should be left floating for maximum flexibility and compatibility with future designs.

| Pin | Function | Pin | Function | Pin | Function | Pin | Function |
|-----|-----------|-----|-----------|-----|------------|-----|-------------|
| 1 | N.C. | 53 | N.C. | 105 | N.C. | 157 | N.C. |
| 2 | N.C. | 54 | N.C. | 106 | N.C. | 158 | N.C. |
| 3 | VSS | 55 | SysCmd2 | 107 | N.C. | 159 | RClock0 |
| 4 | VCC | 56 | SysAD36 | 108 | N.C. | 160 | RClock1 |
| 5 | SysAD45 | 57 | SysAD4 | 109 | VCC | 161 | SyncOut |
| 6 | SysAD13 | 58 | SysCmd1 | 110 | VSS | 162 | SysAD30 |
| 7 | Fault* | 59 | VSS | 111 | SysAD21 | 163 | VCC |
| 8 | SysAD44 | 60 | VCC | 112 | SysAD53 | 164 | VSS |
| 9 | VSS | 61 | SysAD35 | 113 | RdRdy* | 165 | SysAD62 |
| 10 | VCC | 62 | SysAD3 | 114 | ModeIn | 166 | MasterOut |
| 11 | SysAD12 | 63 | SysCmd0 | 115 | SysAD22 | 167 | SysAD31 |
| 12 | SysCmdP | 64 | SysAD34 | 116 | SysAD54 | 168 | SysAD63 |
| 13 | SysAD43 | 65 | VSS | 117 | VCC | 169 | VCC |
| 14 | SysAD11 | 66 | VCC | 118 | VSS | 170 | VSS |
| 15 | VSS | 67 | N.C. | 119 | Release* | 171 | VCCOK |
| 16 | VCC | 68 | N.C. | 120 | SysAD23 | 172 | SysADC3 |
| 17 | SysCmd8 | 69 | SysAD2 | 121 | SysAD55 | 173 | SysADC7 |
| 18 | SysAD42 | 70 | Int5* | 122 | NMI* | 174 | VCC |
| 19 | SysAD10 | 71 | SysAD33 | 123 | VCC | 175 | VSS |
| 20 | SysCmd7 | 72 | SysAD1 | 124 | VSS | 176 | N.C. |
| 21 | VSS | 73 | VSS | 125 | SysADC2 | 177 | N.C. |
| 22 | VCC | 74 | VCC | 126 | SysADC6 | 178 | N.C. |
| 23 | SysAD41 | 75 | Int4* | 127 | VCC | 179 | N.C. |
| 24 | SysAD9 | 76 | SysAD32 | 128 | SysAD24 | 180 | N.C. |
| 25 | SysCmd6 | 77 | SysAD0 | 129 | VCC | 181 | VCCP |
| 26 | SysAD40 | 78 | Int3* | 130 | VSS | 182 | VSSP |
| 27 | N.C. | 79 | VSS | 131 | SysAD56 | 183 | N.C. |
| 28 | N.C. | 80 | VCC | 132 | N.C. | 184 | N.C. |
| 29 | VSS | 81 | Int2* | 133 | SysAD25 | 185 | MasterClock |
| 30 | VCC | 82 | SysAD16 | 134 | SysAD57 | 186 | VCC |
| 31 | SysAD8 | 83 | SysAD48 | 135 | VCC | 187 | VSS |
| 32 | SysCmd5 | 84 | Int1* | 136 | VSS | 188 | SyncIn |
| 33 | SysADC4 | 85 | VSS | 137 | IOOut | 189 | VCC |
| 34 | SysADC0 | 86 | VCC | 138 | SysAD26 | 190 | VSS |
| 35 | VSS | 87 | SysAD17 | 139 | SysAD58 | 191 | N.C. |
| 36 | VCC | 88 | SysAD49 | 140 | IOIn | 192 | SysADC5 |
| 37 | SysCmd4 | 89 | Int0* | 141 | VCC | 193 | SysADC1 |
| 38 | SysAD39 | 90 | SysAD18 | 142 | VSS | 194 | JTDI |
| 39 | SysAD7 | 91 | VSS | 143 | SysAD27 | 195 | VCC |
| 40 | SysCMD3 | 92 | VCC | 144 | SysAD59 | 196 | VSS |
| 41 | VSS | 93 | SysAD50 | 145 | ColdReset* | 197 | SysAD47 |
| 42 | VCC | 94 | ValidIn* | 146 | SysAD28 | 198 | SysAD15 |
| 43 | SysAD38 | 95 | SysAD19 | 147 | VCC | 199 | JTDO |
| 44 | SysAD6 | 96 | SysAD51 | 148 | VSS | 200 | SysAD46 |
| 45 | ModeClock | 97 | VSS | 149 | SysAD60 | 201 | VCC |
| 46 | WrRdy* | 98 | VCC | 150 | Reset* | 202 | VSS |
| 47 | SysAD37 | 99 | ValidOut* | 151 | SysAD29 | 203 | SysAD14 |
| 48 | SysAD5 | 100 | SysAD20 | 152 | SysAD61 | 204 | N.C. |
| 49 | VSS | 101 | SysAD52 | 153 | VCC | 205 | TClock0 |
| 50 | VCC | 102 | ExtRqst* | 154 | VSS | 206 | TClock1 |
| 51 | N.C. | 103 | N.C. | 155 | N.C. | 207 | N.C. |
| 52 | N.C. | 104 | N.C. | 156 | N.C. | 208 | N.C. |

Physical Specifications — 208-pin QFP

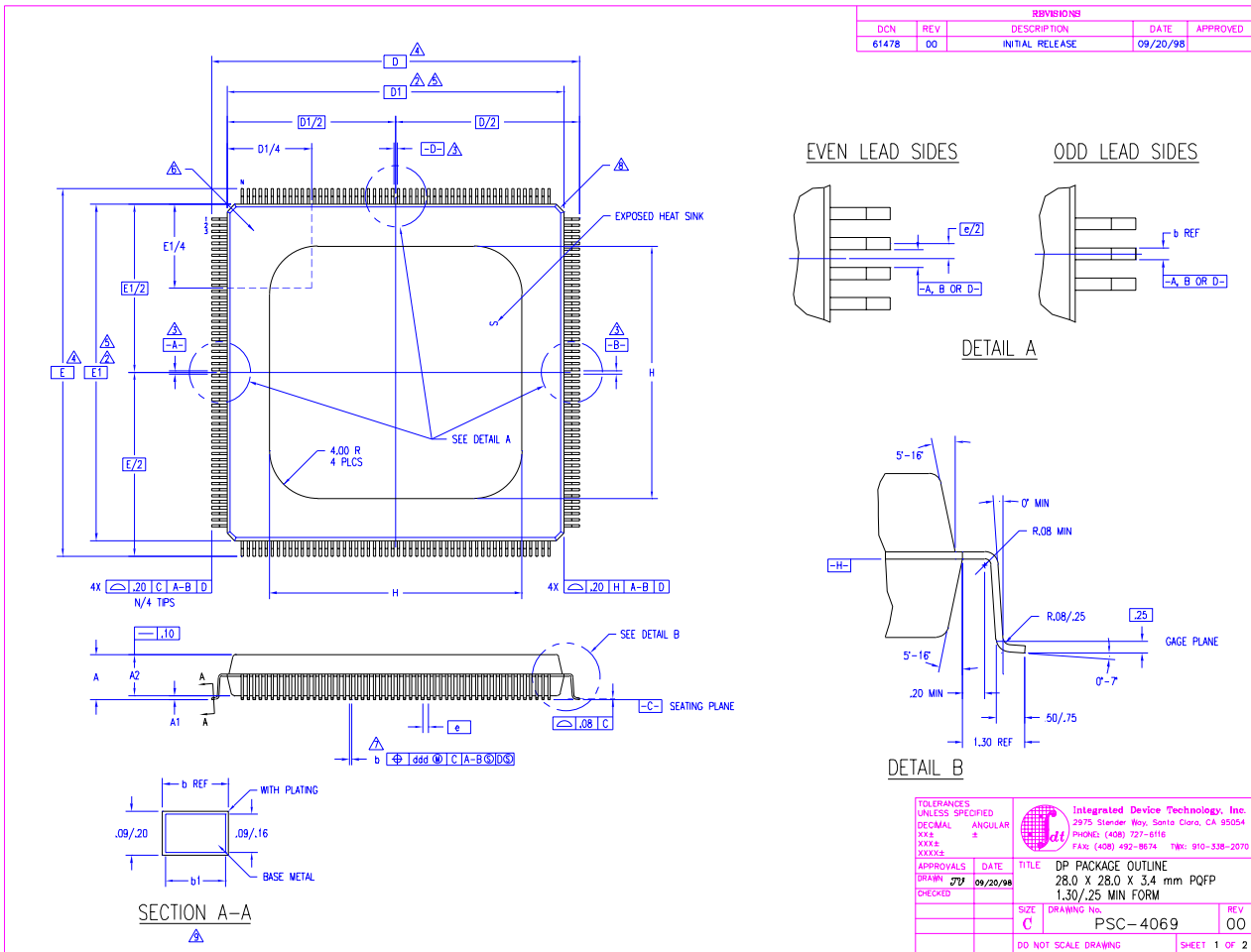

Physical Specifications - page 2

| SYMBOL | JEDEC VARIATION | | | NOTE |
|--------|-----------------|------|------|------|
| | FA-1 | | | |
| | MIN | NOM | MAX | |
| A | - | - | 4.10 | |
| A1 | .25 | - | - | |
| A2 | 3.20 | 3.40 | 3.60 | |
| D | 30.60 BSC | | | 4 |
| D1 | 28.00 BSC | | | 5,2 |
| E | 30.60 BSC | | | 4 |
| E1 | 28.00 BSC | | | 5,2 |
| H | 21.00 REF | | | |
| N | 208 | | | |
| e | .50 BSC | | | |
| b | .17 | - | .27 | 7 |
| b1 | .17 | .20 | .23 | |
| ddd | - | - | .08 | |

NOTES:

- 1 ALL DIMENSIONING AND TOLERANCING CONFORM TO ASME Y14.5M-1994
- ⚠ TOP PACKAGE MAY BE SMALLER THAN BOTTOM PACKAGE BY .15 mm
- ⚠ DATUMS [A-B] AND [-D-] TO BE DETERMINED AT DATUM PLANE [-H-]
- ⚠ DIMENSIONS D AND E ARE TO BE DETERMINED AT SEATING PLANE [-C-]
- ⚠ DIMENSIONS D1 AND E1 DO NOT INCLUDE MOLD PROTRUSION. ALLOWABLE MOLD PROTRUSION IS .25 mm PER SIDE. D1 AND E1 ARE BODY SIZE DIMENSIONS INCLUDING MOLD MISMATCH
- ⚠ DETAIL OF PIN 1 IDENTIFIER IS OPTIONAL BUT MUST BE LOCATED WITHIN THE ZONE INDICATED
- ⚠ DIMENSION b DOES NOT INCLUDE DAMBAR PROTRUSION. ALLOWABLE DAMBAR PROTRUSION IS .08 mm IN EXCESS OF THE b DIMENSION AT MAXIMUM MATERIAL CONDITION. DAMBAR CANNOT BE LOCATED ON THE LOWER RADIUS OR THE FOOT.
- ⚠ EXACT SHAPE OF EACH CORNER IS OPTIONAL
- ⚠ THESE DIMENSIONS APPLY TO THE FLAT SECTION OF THE LEAD BETWEEN .10 AND .25 mm FROM THE LEAD TIP
- 10 ALL DIMENSIONS ARE IN MILLIMETERS
- 11 THIS OUTLINE CONFORMS TO JEDEC PUBLICATION 95 REGISTRATION MO-143, VARIATION FA-1

| REVISIONS | | | | |
|-----------|-----|-----------------|----------|----------|
| DCN | REV | DESCRIPTION | DATE | APPROVED |
| 61478 | 00 | INITIAL RELEASE | 09/20/98 | |

LAND PATTERN DIMENSIONS

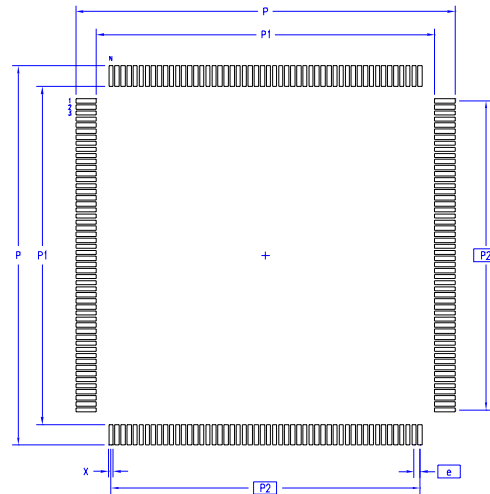

| | MIN | MAX |
|----|-----------|-------|
| P | 31.20 | 31.40 |
| P1 | 27.80 | 28.00 |
| P2 | 25.50 BSC | |
| X | .30 | .40 |
| e | .50 BSC | |
| N | 208 | |

| | | |
|-----------------------------|----------|-------------------------------------------------------------------------------------------------------------------------------------------------|
| TOLERANCES UNLESS SPECIFIED | | Integrated Device Technology, Inc. 2975 Slender Way, Santa Clara, CA 95054 PHONE: (408) 727-6116 FAX: (408) 492-8674 TWR: 910-338-2070 |
| DECIMAL | ANGULAR | |
| xxx | ± | |
| xxxx | | |
| xxxxx | | |
| APPROVALS | DATE | TITLE |
| DRAWN JT | 09/20/98 | DP PACKAGE OUTLINE |
| CHECKED | | 28.0 X 28.0 X 3.4 mm PQFP |
| | | 1.30/.25 MIN FORM |
| | SIZE C | DRAWING No. PSC-4069 |
| | | REV 00 |
| DO NOT SCALE DRAWING | | SHEET 2 OF 2 |

RC4700 PGA Package Pin-Out

Note: N.C. pins should be left floating for maximum flexibility and compatibility with future designs.

| Function | Pin | Function | Pin | Function | Pin |
|------------------|-----|----------|-----|----------|-----|
| ColdReset* | T14 | SysAD36 | C3 | VCC | B18 |
| ExtRqst* | U2 | SysAD37 | B3 | VCC | C1 |
| Fault* | B16 | SysAD38 | C6 | VCC | D18 |
| Reserved O (NC) | U10 | SysAD39 | C7 | VCC | F1 |
| Reserved I (Vcc) | T9 | SysAD40 | C10 | VCC | G18 |
| IOIn | T13 | SysAD41 | C11 | VCC | H1 |
| IOOut | U12 | SysAD42 | B13 | VCC | J18 |
| Int0 | N2 | SysAD43 | A15 | VCC | K1 |
| Int1 | L3 | SysAD44 | C15 | VCC | L18 |
| Int2 | K3 | SysAD45 | B17 | VCC | M1 |
| Int3 | J3 | SysAD46 | E17 | VCC | N18 |
| Int4 | H3 | SysAD47 | F17 | VCC | R1 |
| Int5 | F2 | SysAD48 | L2 | VCC | T18 |
| MasterClock | J17 | SysAD49 | M3 | VCC | U1 |
| MasterOut | P17 | SysAD50 | N3 | VCC | V3 |
| ModeClock | B4 | SysAD51 | R2 | VCC | V6 |
| Modeln | U4 | SysAD52 | T3 | VCC | V8 |
| NMI | U7 | SysAD53 | U3 | VCC | V10 |
| RClock0 | T17 | SysAD54 | T6 | VCC | V12 |
| RClock1 | R16 | SysAD55 | T7 | VCC | V14 |
| RdRdy* | T5 | SysAD56 | T10 | VCC | V17 |
| Release | V5 | SysAD57 | T11 | VSS | A3 |
| Reset* | U16 | SysAD58 | U13 | VSS | A6 |
| SyncIn | J16 | SysAD59 | V15 | VSS | A8 |
| SyncOut | P16 | SysAD60 | T15 | VSS | A10 |
| SysAD0 | J2 | SysAD61 | U17 | VSS | A12 |
| SysAD1 | G2 | SysAD62 | N16 | VSS | A14 |
| SysAD2 | E1 | SysAD63 | N17 | VSS | A17 |
| SysAD3 | E3 | SysADC0 | C8 | VSS | A18 |
| SysAD4 | C2 | SysADC1 | G17 | VSS | B1 |
| SysAD5 | C4 | SysADC2 | T8 | VSS | C18 |
| SysAD6 | B5 | SysADC3 | L16 | VSS | D1 |
| SysAD7 | B6 | SysADC4 | B8 | VSS | F18 |
| SysAD8 | B9 | SysADC5 | H16 | VSS | G1 |
| SysAD9 | B11 | SysADC6 | U8 | VSS | H18 |
| SysAD10 | C12 | SysADC7 | L17 | VSS | J1 |
| SysAD11 | B14 | SysCmd0 | E2 | VSS | K18 |
| SysAD12 | B15 | SysCmd1 | D3 | VSS | L1 |
| SysAD13 | C16 | SysCmd2 | B2 | VSS | M18 |
| SysAD14 | D17 | SysCmd3 | A5 | VSS | N1 |
| SysAD15 | E18 | SysCmd4 | B7 | VSS | P18 |
| SysAD16 | K2 | SysCmd5 | C9 | VSS | R18 |
| SysAD17 | M2 | SysCmd6 | B10 | VSS | T1 |
| SysAD18 | P1 | SysCmd7 | B12 | VSS | U18 |
| SysAD19 | P3 | SysCmd8 | C13 | VSS | V1 |
| SysAD20 | T2 | SysCmdP | C14 | VSS | V2 |

| Function | Pin | Function | Pin | Function | Pin |
|----------|-----|------------------|-----|----------|-----|
| SysAD21 | T4 | TClock1 | C17 | VSS | V4 |
| SysAD22 | U5 | TClock0 | D16 | VSS | V7 |
| SysAD23 | U6 | VCCOk | M17 | VSS | V9 |
| SysAD24 | U9 | ValidIn* | P2 | VSS | V11 |
| SysAD25 | U11 | ValidOut* | R3 | VSS | V13 |
| SysAD26 | T12 | WrRdy* | C5 | VSS | V16 |
| SysAD27 | U14 | VCCP | K17 | VSS | V18 |
| SysAD28 | U15 | VSSP | K16 | JTMS | E16 |
| SysAD29 | T16 | VCC | A2 | JTDO | F16 |
| SysAD30 | R17 | VCC | A4 | JTDI | G16 |
| SysAD31 | M16 | Reserved I (VCC) | A7 | JTCK | H17 |
| SysAD32 | H2 | VCC | A9 | | |
| SysAD33 | G3 | VCC | A11 | | |
| SysAD34 | F3 | VCC | A13 | | |
| SysAD35 | D2 | VCC | A16 | | |

Physical Specifications — PGA

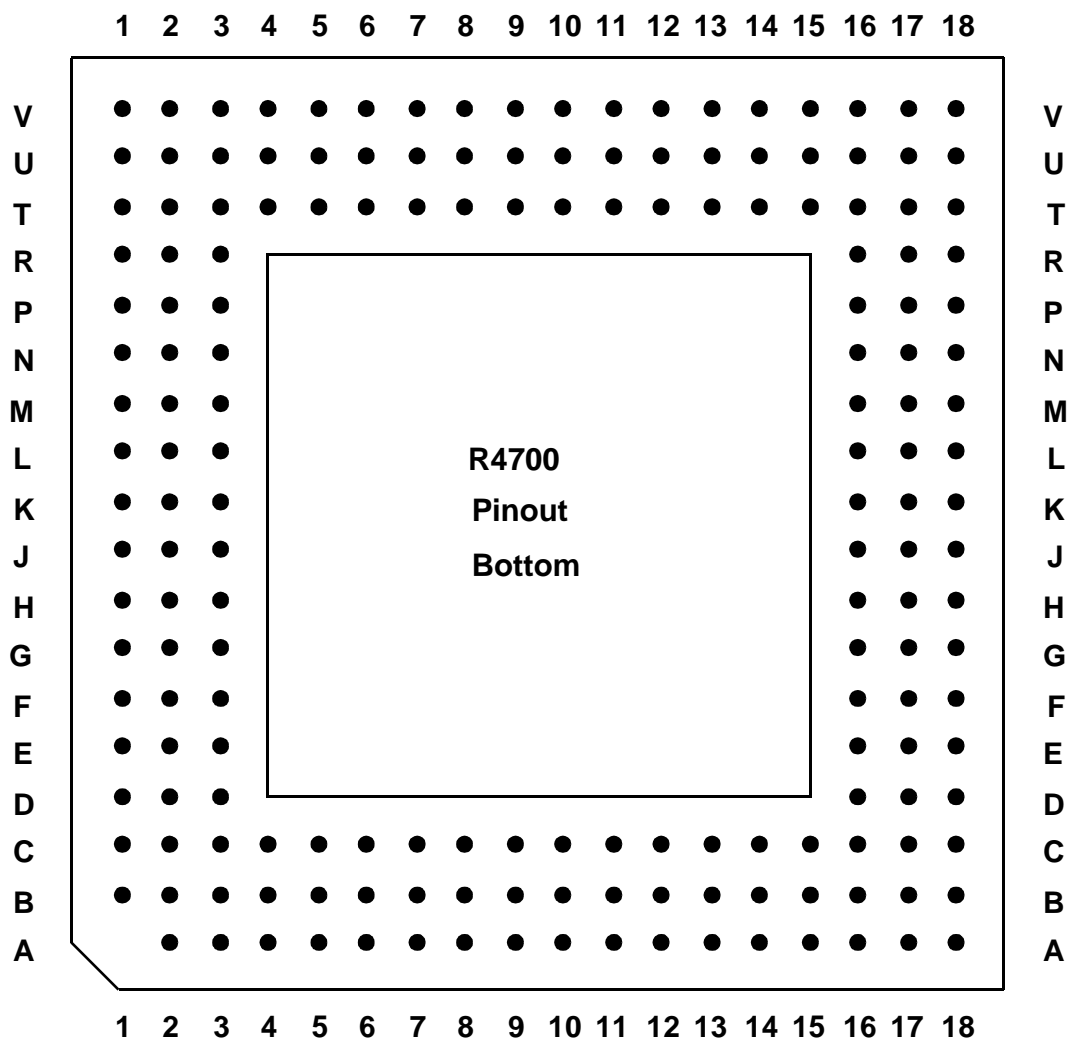

2884 drw 12

Ordering Information

| IDT79 | YY | XXXX | 999 | A | A | | |
|---------------|-------------|-------|---------|----------------------------|-------|----------------------------------|--|
| Configuration | Device Type | Speed | Package | Process/ Temperature Range | | | |
| | | | | | Blank | Commercial (0°C to +85°C (Case)) | |
| | | | | | GH | PGA 179 | |
| | | | | | DP | 208-Pin QFP | |
| | | | | | 80 | 80 MHz | |
| | | | | | 100 | 100 MHz | |
| | | | | | 133 | 133 MHz | |
| | | | | | 150 | 150 MHz | |
| | | | | | 175 | 175 MHz | |
| | | | | | 200 | 200 MHz | |
| | | | | | 4700 | Enhanced 64-bit CPU | |
| | | | | | RV | 3.3V± 5% | |
| | | | | | R | 5.0V± 5% | |

Valid Combinations

IDT79R4700 - 80, 100, 133 - GH, DP

PGA, QFP Package

IDT79RV4700 -100, 133, 150, 175, 200 - GH, DP

PGA, QFP Package



CORPORATE HEADQUARTERS
 2975 Stender Way
 Santa Clara, CA 95054

for SALES:
 800-345-7015 or 408-727-6116
 fax: 408-330-1748
 www.idt.com

for Tech Support:
 email: rischelp@idt.com
 phone: 408-492-8208

The IDT logo is a registered trademark of Integrated Device Technology, Inc.