



StrongARM™ SA-1100 Microprocessor for Portable Applications

Brief Datasheet

Product Features

The StrongARM™ SA-1100 Microprocessor (SA-1100) is a device targeted to provide portable applications with high-end computing performance without requiring users to sacrifice available battery time. The SA-1100 incorporates a 32-bit StrongARM™ RISC processor with instruction and data cache, memory-management unit (MMU), and read/write buffers running at 133/190 MHz. In addition, the SA-1100 provides system support logic, multiple serial communication channels, a color/gray scale LCD controller, PCMCIA support for up to two sockets, and general-purpose I/O ports.

- High performance
 - 150 Dhrystone 2.1 MIPS @ 133 MHz
 - 220 Dhrystone 2.1 MIPS @ 190 MHz
- Low power (normal mode)[†]
 - <230 mW @ 1.5 V/133 MHz
 - <330 mW @ 1.5 V/190 MHz
- Integrated clock generation
 - Internal phase-locked loop (PLL)
 - 3.686-MHz oscillator
 - 32.768-kHz oscillator
- Power-management features
 - Normal (full-on) mode
 - Idle (power-down) mode
 - Sleep (power-down) mode
- Big and little endian operating modes
- 3.3-V I/O interface
- 208-pin thin quad flat pack (LQFP)
- 256 mini-ball grid array (mBGA)
- 32-way set-associative caches
 - 16 Kbyte instruction cache
 - 8 Kbyte write-back data cache
- 32-entry MMUs
 - Maps 4 Kbyte, 8 Kbyte, or 1 Mbyte
- Write buffer
 - 8-entry, between 1 and 16 bytes each
- Read buffer
 - 4-entry, 1, 4, or 8 words
- Memory bus
 - Interfaces to ROM, Flash, SRAM, and DRAM
 - Supports two PCMCIA sockets

[†] Power dissipation, particularly in idle mode, is strongly dependent on the details of the system design



Information in this document is provided in connection with Intel products. No license, express or implied, by estoppel or otherwise, to any intellectual property rights is granted by this document. Except as provided in Intel's Terms and Conditions of Sale for such products, Intel assumes no liability whatsoever, and Intel disclaims any express or implied warranty, relating to sale and/or use of Intel products including liability or warranties relating to fitness for a particular purpose, merchantability, or infringement of any patent, copyright or other intellectual property right. Intel products are not intended for use in medical, life saving, or life sustaining applications.

Intel may make changes to specifications and product descriptions at any time, without notice.

Contact your local Intel sales office or your distributor to obtain the latest specifications and before placing your product order.

Copies of documents which have an ordering number and are referenced in this document, or other Intel literature may be obtained by calling 1-800-548-4725 or by visiting Intel's website at <http://www.intel.com>.

Copyright © Intel Corporation, 1998

*Third-party brands and names are the property of their respective owners.

ARM, the ARM Powered logo, and StrongARM are trademarks of Advanced RISC Machines Limited.



Benefits

- Ensures low-power performance for any mobile product demanding low power without sacrificing battery time.
- Achieves high-end desktop performance through delivering Softmodem^{*}, speech recognition, and text-to-speech capabilities without a reduction in user-interface performance.
- Delivers price/performance for multimedia and graphics capabilities demanded by digital/analog I/O devices.
- Speeds time to market with its complete suite of software and hardware tools.
- Reduces design effort and cost with its compatibility with ARM[™] and the availability of key third-party development tools (real-time operating systems).
- Provides record-breaking Java^{*} performance, generating CaffeineMark^{*} performances equivalent to, or better than processors 10 times the price of the SA-1100.

Applications

- Handheld personal computers (HPCs)
- Smart phones
- Digital cameras
- Subnotebooks
- Wallet personal computers
- Portable network computers

Operating Systems

- Sun Microsystems
- JMI
- Lucent
- Microsoft
- Microware
- Apple Computer, Inc.
- Psion
- Wind River
- JavaOS^{*}
- C EXECUTIVE^{*}
- Inferno^{*}
- Windows CE^{*}
- OS-9^{*}
- Newton OS^{*}
- EPOC32^{*}
- VxWorks^{*}

Description

The SA-1100 is a general-purpose, 32-bit RISC microprocessor with a 16 Kbyte instruction cache (Icache), an 8 Kbyte write-back data cache (Dcache), a minicache, a write buffer, a read buffer, an MMU, an LCD controller, and serial I/O combined in a single chip. The SA-1100 provides power-management functionality and offers further power savings and integration by including oscillators and PLLs on-chip. The SA-1100 delivers both extensive system integration and high-end desktop performance without sacrificing power or price, making the SA-1100 a choice for many portable systems.

SA-1100 CPU

The SA-1100 CPU implements the ARM V4 architecture as defined in the *ARM Architecture Reference Manual*. Architectural enhancements beyond the ARM V4 are implemented through use of coprocessor 15. Control register reads and writes to coprocessor 15 provide access to MMU, cache, and write and read buffer control registers.

The SA-1100 MMUs provide separate 32-entry translation lookaside buffers (TLBs) for the instruction and data streams. Each of the 32 entries may map segments, large pages, or small pages in memory. The SA-1100 contains 16 Kbyte of instruction cache and 8 Kbyte of data cache. In

In addition to this, a minicache is provided to prevent periodic large data transfers from thrashing the main data cache. The data and instruction caches are implemented as 32-byte blocks, and provide 32-way associativity, with victim replacement performed in a round-robin fashion. The minicache is 16 entries and is 2-way set associative, implementing the least-recently-used (LRU) algorithm for victim replacement.

The SA-1100 also provides a write buffer and a read buffer. The read buffer allows critical data to be prefetched under software control, preventing pipeline stalls from occurring during external memory reads. The write buffer provides additional system efficiency by buffering between the CPU clock frequency and the actual bus speed when data is being written by the CPU to external memory. The write buffer is eight entries, and allows each entry to contain between 1 and 16 bytes. The read buffer is four entries, and allows each entry to contain 1, 4, or 8 words.

SA-1100 System Control Functions

The SA-1100 provides timers, sophisticated power-management functions, interrupt control, reset control, and onchip oscillators and PLLs for clock generation. There are 28 general-purpose I/Os, which can, in addition to being directly read or written by the CPU, be programmed to generate an interrupt.

The real-time clock and trim logic run off the 32.768-kHz crystal and provide accuracy of ± 5 seconds/month.

The 32-bit OS timer runs off the 3.686-MHz oscillator and is used in companion with the four 32-bit timer match registers. One of the four match registers is used specifically as a watchdog timer interrupt, preventing system lockout from occurring when software or hardware is trapped in a loop state with no controlled exit. The remaining three registers are available for use as interval timers or other user-defined purposes.

The interrupt controller routes all interrupt sources to either an FIQ or IRQ request to the CPU. IRQ is a lower priority interrupt and may be interrupted by FIQ. FIQ is unique to the ARM architecture and allows fast servicing to occur on specific interrupt sources, as determined by the user. There are two levels in servicing interrupts. The first level alerts the user or operating system to what specific module on the SA-1100 experienced an interrupt condition. The second level provides information on what event within the specific module caused an interrupt to be flagged.

The reset controller manages the various reset sources within the SA-1100 and provides the ability to invoke a software reset. In addition, the reset controller tracks the cause of the last known reset, whether a hard reset, soft reset, watchdog timer expiration, or sleep mode reset.

The SA-1100 provides 28 general-purpose I/O pins, which may be programmed to generate interrupts on rising, falling, or both edges. The user is given the option of utilizing a subset of the GPIO pins to support extra functionality in either the serial channels or the LCD controller but may choose to use some, all, or none of the added functionality.

Power-Management Functions

Power management provides three modes of operation: normal, idle, and sleep. In normal mode, the CPU and peripherals are fully powered, but receive active clocks only when in use. In idle mode, clocks to the CPU are stopped, but the clocks to the peripheral functions are active. Power dissipation during idle mode is strongly dependent on the details of the system design. The SA-1100 returns to normal mode from idle mode upon receipt of any enabled interrupt, including interrupts resulting from timers expiring.

In sleep mode, once DRAM is placed in self-refresh, all functions are disabled except for the real-time clock. Wake-up from sleep occurs upon a preprogrammed interrupt and takes 10 ms if the 3.686-MHz clock is enabled or 160 ms if the 3.686-MHz clock is disabled.

SA-1100 Memory Control Module

The SA-1100 contains a flexible memory controller that can access DRAM, EDO DRAM, SRAM, Flash, and ROM. The SA-1100 memory map supports up to four banks of DRAM; each bank provides 128 Mbytes of addressable space allowing both currently available and future memory densities to be supported. The DRAM controller supports CBR as well as self-refresh DRAM. Burst reads occur in 1, 2, 3, 4, or 8 words (beats) as determined by the data destination within the SA-1100 (cache line fill, read buffer, or DMA). Burst writes occur in 1, 2, 3, 4, or 8 words, depending on the final destination of the data outside the SA-1100 (write buffer, DMA). When a castout is occurring from cache, the SA-1100 will perform an 8-word write for a full 32 bytes.

Included in the SA-1100 memory controller is support for up to two slots of PCMCIA. The implementation shares address and data pins with the memory controller. Access speeds to PCMCIA memory and I/O are user-programmable. Some external buffering is required for this interface.

SA-1100 Peripheral Control Module

The SA-1100 contains a six-channel DMA controller to support the high-speed data movement inherent in serial communications. Note that the LCD controller contains its own independent DMA channels, and that the six DMA channels are available for use by the other peripheral I/O functions. The DMA controller is dedicated to data movement between the serial channels and external memory, whether DRAM, SRAM, Flash, or ROM.

The LCD controller on the SA-1100 supports up to 256 colors and 16 gray-scale levels, on a single or split-screen display with resolution up to 1024 X 1024. The LCD controller is implemented using a patented dithering algorithm controlling the intensity of the information displayed. In the case of color, the dithering algorithm controls which 256 of the 4096 available colors are displayed during any given frame. Frame buffer data is used by the LCD controller as an address value, which is then decoded as an index into a 256-entry by 12-bit wide palette RAM. If 12-bit data is required, the palette RAM may be bypassed and frame buffer data passes directly to the dither logic. If 16-bit data is required, both the palette RAM and the dither logic are bypassed, and data is sent directly to the LCD controller pins. The LCD controller supports both TFT and STN panels.

Serial port 0 on the SA-1100 implements the universal serial bus (USB) slave protocol, supporting three endpoints operating at 12 Mbps, half duplex.

Serial port 1 on the SA-1100 implements either the synchronous data link controller (SDLC) or universal asynchronous receiver-transmitter (UART), both at baud rates up to 230 Kbps. If both SDLC and UART are required in a given system, two GPIO pins can be configured to perform the UART RX/TX functionality, leaving the TX_2/RX_2 pins free for SDLC.

Serial port 2 on the SA-1100 provides logic to support infrared data (IrDA) at either 115 Kbps or 4 Mbps. The low-speed IrDA utilizes the HP-SIR* standard, and the high-speed IrDA implements the 4 PPM standard.

Serial port 3 on the SA-1100 is a UART channel operating from 56.24 bps to 230 Kbps. Modem control signals may be implemented via the GPIO pins if required, but for maximum flexibility these signals are not predefined.

Serial port 4 on the SA-1100 also implements a multimedia communications port or synchronous serial port (MCP/SSP). These ports are traditionally used for interfacing to specific digital/analog I/O devices such as codecs, keyboards, touchpads, audio and record/playback. If required, the SA-1100 provides the user with an option to support both the MCP as well as SSP by dedicating two GPIO pins to the SSP.

The MCP gluelessly interfaces to the Philips UCB1200^{*}, which provides support for both audio and telecom codecs as well as a touchpad interface and 10 general-purpose I/O pins. The SA-1100 contains two pairs of transmit and receive FIFOs to support the telecom and audio data. The SA-1100 also provides two 21-bit data registers, one each for receive and transmit codec data. The SSP logic interfaces to devices that support the National MicroWire^{*} protocol, the Texas Instruments^{*} synchronous serial protocols, as well as a subset of the Motorola SPI^{*} protocol. All of these protocols provide methods to interface to keyboard drivers, serial EPROMs, ADC/DAC, as well as special-purpose devices such as voice record/playback. The SSP functions as a master only, communicating to offchip devices by driving a serial bit-rate clock ranging from 7.2 kHz to 1.8432 MHz, and supports data formats from 4 to 16 bits in length.

SA-1100 Test and Debug Support

The SA-1100 provides debug support via instruction and data breakpoints. These are user-programmable and are implemented through the coprocessor instructions. In the case of an instruction breakpoint, the user may halt the processor after execution of an instruction at a specific address. The data breakpoint allows a user to halt on a specific data pattern as well as on the reference address to that data pattern. There is a data breakpoint mask register that provides further qualification on specific data.

The SA-1100 also provides a JTAG interface, which has been specifically targeted to provide continuity checking for system designs. Supported instructions include EXTEST, SAMPLE/PRELOAD, CLAMP, BYPASS, HIGH-Z, and IDCODE.

Tool Chains and Operating Systems

The SA-1100 has an extensive list of supporting operating systems and tool chains. See Table 2 for a subset of the available operating systems.

SA-1100 Power Benefits

The SA-1100 continues the StrongARM family legacy of low-power performance. The SA-1100 takes advantage of a 2.0-V nominal process technology allowing the core voltage to run at 1.5 V. The I/O ring runs at 3.3 V to allow simple system interconnections. Another key element in the SA-1100 power strategy is the use of independent conditional clocking trees, which ensure that only currently required units are clocked and other units remain static. The SA-1100 may be run at a variety of frequencies, ranging from 39 MHz up to 190 MHz.

SA-1100 Performance Benefits

The SA-1100 provides high-end desktop performance to the consumer market without sacrificing power or price. Applications utilizing the SA-1100 are able to take advantage of technology such as Softmodem^{*}, speech recognition, and text-to-speech without a reduction in user-interface performance. Use of the performance-intensive Softmodem^{*} algorithm provides significant savings in overall system cost. When running on the SA-1100, a Softmodem^{*} requires less than 30% of the processor bandwidth, ensuring that none of the other SA-1100 functions, including LCD display and serial channel operation, experience a degradation in performance.

Another advantage to the performance provided by the SA-1100 becomes apparent with the adoption of interpreted languages. An example of this is demonstrated by comparing the CaffeineMark^{*} performance of the ARM SA-1 core on the SA-1100 to other competing parts in the market. The ARM SA-1 core outperformed processors more than 10 times the price of the SA-1100 when running Java^{*}.

Figure 1. Block Diagram of the SA-1100

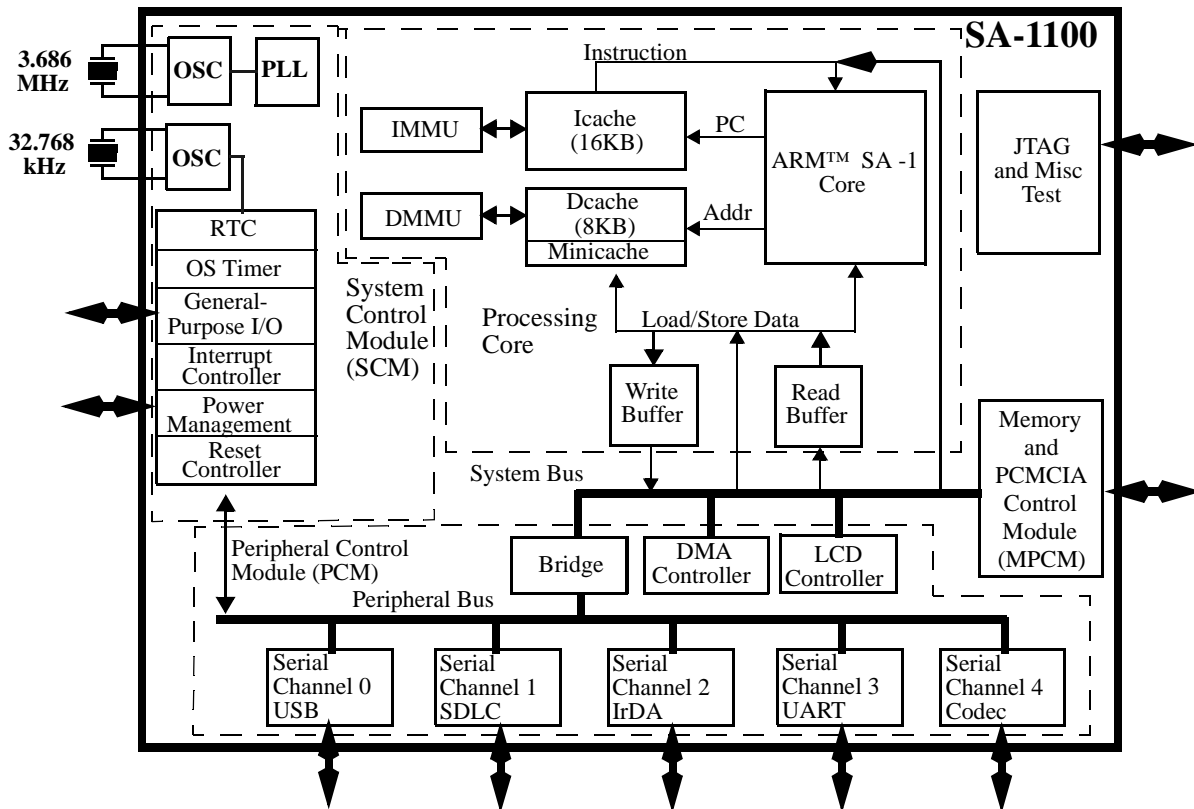

Table 1. SA-1100 Additional Features

Supply	1.5 V
USB	12 Mbps
IrDA	115 Kbps, 4 Mbps
SDLC	230 Kbps
UART	230 Kbps
Codec	UCB1100, UCB1200, SPI, TI, μ Wire
LCD	1-, 2-, 4-, 8-, 12-, 16-bits/pixel
Memory	EDO, DRAM, ROM, Flash, SRAM
Interrupt	FIQ, IRQ, Wake-up

Table 2. SA-1100 Tool Chains and Operating Systems

Manufacturer	Operating System	Tool Chain
Apple Computer, Inc.	Newton OS*	Newton Developer Tools*
JMI	C EXECUTIVE*	Multiple sources
Lucent	Inferno*	Inferno Toolkit*
Microsoft	Windows CE*	Visual C/C++*
Microware	OS-9*	FasTrac*
Psion	EPOC32*	GNU*
Sun Microsystems	JavaOS*	JDK*, JavaWorks*
Wind River	VxWorks*	Tornado*

Table 3. SA-1100 Characteristics

Clock	133 MHz	190 MHz
Performance	150 Dhrystone 2.1 MIPS	220 Dhrystone 2.1 MIPS
Core power supply	V_{ss} = 0.0 V dc V_{dd} = 1.5 V dc ± 5%	V_{ss} = 0.0 V dc V_{dd} = 1.5 V dc ± 5%
I/O power supply	V_{ssx} = 0.0 V dc V_{ddx} = 3.3 V dc ± 10%	V_{ssx} = 0.0 V dc V_{ddx} = 3.3 V dc ± 10%
Typical power dissipation [†]	Normal mode = <230 mW Idle mode = <50 mW Sleep mode = <50 μA	Normal mode = <330 mW Idle mode = <65 mW Sleep mode = <50 μA
Ambient operating temperature	Standard = 0°C (32°F) min. 70°C (158°F) max. Extended ^{††} = -20°C (-4°F) min. 70°C (158°F) max.	Standard = 0°C (32°F) min. 70°C (158°F) max. Extended ^{††} = -20°C (-4°F) min. 70°C (158°F) max.
Storage temperature	-40°C to +125°C (-40°F to +257°F)	-40°C to +125°C (-40°F to +257°F)
Packaging	208-pin LQFP ^{†††} 256 mBGA	208-pin LQFP ^{†††} 256 mBGA
Process technology	.35 μm, 3-layer metal	.35 μm, 3-layer metal
Transistor count	2.5 million	2.5 million
Order number	DE-S1100-AA (LQFP) DE-S1100-AB (mBGA)	DE-S1100-EA (LQFP) DE-S1100-EB (mBGA)

[†] Power dissipation, particularly in idle mode, is strongly dependent on the details of the system design.

^{††} Customized part.

^{†††} Package nomenclature as been modified due to industry standardization of packages. LQFP is 1.4 mm thick, thin quad flat pack. Please note that *no* modification has been made to the package itself.

Support, Products, and Documentation

If you need technical support, a *Product Catalog*, or help deciding which documentation best meets your needs, visit the Intel World Wide Web Internet site:

<http://www.intel.com>

Copies of documents that have an ordering number and are referenced in this document, or other Intel literature may be obtained by calling **1-800-332-2717** or by visiting Intel's website for developers at:

<http://developer.intel.com>

You can also contact the Intel Massachusetts Information Line or the Intel Massachusetts Customer Technology Center. Please use the following information lines for support:

For documentation and general information:	
Intel Massachusetts Information Line	
United States:	1-800-332-2717
Outside United States:	1-303-675-2148
Electronic mail address:	techdoc@intel.com
For technical support:	
Intel Massachusetts Customer Technology Center	
Phone (U.S. and international):	1-978-568-7474
Fax:	1-978-568-6698
Electronic mail address:	techsup@intel.com

