



Pentium® II Processor Mobile Module: Embedded Module Connector 2 at 266 MHz (EMC-2) Design Guide

Application Note

November 1998

Order Number: 273212-001



Information in this document is provided in connection with Intel products. No license, express or implied, by estoppel or otherwise, to any intellectual property rights is granted by this document. Except as provided in Intel's Terms and Conditions of Sale for such products, Intel assumes no liability whatsoever, and Intel disclaims any express or implied warranty, relating to sale and/or use of Intel products including liability or warranties relating to fitness for a particular purpose, merchantability, or infringement of any patent, copyright or other intellectual property right. Intel products are not intended for use in medical, life saving, or life sustaining applications.

Intel may make changes to specifications and product descriptions at any time, without notice.

Designers must not rely on the absence or characteristics of any features or instructions marked "reserved" or "undefined." Intel reserves these for future definition and shall have no responsibility whatsoever for conflicts or incompatibilities arising from future changes to them.

The Mobile Pentium® II Processor may contain design defects or errors known as errata which may cause the product to deviate from published specifications. Current characterized errata are available on request.

Contact your local Intel sales office or your distributor to obtain the latest specifications and before placing your product order.

Copies of documents which have an ordering number and are referenced in this document, or other Intel literature may be obtained by calling 1-800-548-4725 or by visiting Intel's website at <http://www.intel.com>.

Copyright © Intel Corporation, 1998

*Third-party brands and names are the property of their respective owners.

Contents

1.0	Introduction	9
	1.1 Key Terms	9
	1.2 Overview	9
	1.3 Related Documents	11
2.0	Design Features	12
	2.1 Mobile Pentium® II Processor	12
	2.2 Intel® 440BX AGPset	12
	2.2.1 System Bus Interface	13
	2.2.2 DRAM Interface	13
	2.2.3 Accelerated Graphics Port Interface	13
	2.2.4 PCI Interface	13
	2.2.5 System Clocking	13
	2.3 PCI ISA IDE Xcelerator (PIIX4E)	14
3.0	Memory Guidelines	14
	3.1 DRAM Interface Overview	14
	3.1.1 Pin Groups	15
	3.1.2 Single Set DRAM Interface	16
	3.1.2.1 EDO DRAM	16
	3.1.2.2 SDRAM	16
	3.2 DRAM Layout Guidelines	16
	3.2.1 SODIMM Connection - EDO DRAMs	17
	3.2.2 SODIMM Connection - SDRAM	20
	3.2.3 Memory Trace Lengths for Module Design	22
	3.3 SODIMM DRAM Organization	23
	3.3.1 64-Mbit SDRAM System Examples	23
4.0	Clocking Guidelines	25
	4.1 Clocking System Overview	25
	4.2 Clock Synthesizer Pinout and Specifications	26
	4.3 Timing Guidelines	27
	4.4 Clock Layout Guidelines	28
	4.5 Optional Clock Layout	30
	4.6 Clock Vendors	30
5.0	82443BX AGP Interface for EMC-2 Design	31
	5.1 Layout and Routing Guidelines	31
	5.1.1 On-board AGP Compliant Device Layout Guidelines	31
	5.1.1.1 Data and Strobe Signal Routing Recommendations	32
	5.1.1.2 Control Signal Routing Recommendations	32
	5.2 ACPI Compliance Requirements	33
	5.3 AGP IDSEL Routing	33
6.0	Design Guideline Checklists	33
	6.1 Resistor Values	33
	6.2 EMC-2 Design Checklist	34

6.2.1	EMC-2 Errata	34
6.2.2	Power and Ground Pins	34
6.2.3	Decoupling Requirements	35
6.2.4	Clock and Test Signals	35
6.2.5	SDRAM and EDO Signals.....	36
6.2.6	Module Strapping Options.....	36
6.2.7	PCI Bus Signals	36
6.2.7.1	Design Considerations	37
6.2.8	Processor/PIIX4E ISA Bridge Sideband Signals.....	37
6.2.9	Power Management Signals	38
6.2.10	AGP Signals.....	38
6.3	82371EB (PIIX4E) Design Checklist.....	40
6.3.1	82371EB (PIIX4E) Errata	40
6.3.2	Power and Ground Pins	40
6.3.3	Clock and Test Signals	41
6.3.4	PCI Bus Signals	41
6.3.5	ISA/EIO Signals	42
6.3.6	Power Management Signals	43
6.3.7	USB Interface	44
6.3.8	IDE Interface	44
6.3.9	BIOS to Flash Memory Interface.....	45
7.0	Power Sequencing.....	46
7.1	PIIX4E Power Sequencing.....	46
7.1.1	Power Sequencing Requirements.....	46
7.1.2	Suspend/Resume and Power Plane Control.....	46
7.1.2.1	Power On Suspend (POS) System Model	47
7.1.2.2	Suspend to RAM (STR).....	47
7.1.2.3	Suspend to Disk (STD) and Soft Off (SOff).....	47
7.1.2.4	Mechanical Off (MOff)	47
7.1.3	System Resume	48
7.1.3.1	System Resume Events	49
7.1.3.2	Global Standby Timer Resume	49
7.1.4	System Suspend and Resume Control Signaling	50
7.1.4.1	Power Well and Reset Signal Timings	50
7.1.4.2	PIIX4E Power Well Timings	51
7.1.4.3	RSMRST# and PWROK Timing.....	51
7.1.4.4	Suspend Well Power and RSMRST# Activated Signals	52
7.1.4.5	PCI Clock Control Timings	53
7.1.4.6	Core Well Power and PWROK Activated Signals (RSMRST# Inactive Before Core Well Power Applied)	54
7.1.4.7	Core Well Power and PWROK Activated Signals (Core Well Power Applied Before RSMRST# Inactive).....	55
7.1.5	Power Management State Transition Timings	57
7.1.5.1	Mechanical Off to On.....	57
7.1.5.2	On to POS.....	58
7.1.5.3	POS to On (with Processor and PCI Reset).....	59
7.1.5.4	POS to On (with Processor Reset).....	60
7.1.5.5	POS to On (No Reset).....	61
7.1.5.6	On to STR	62
7.1.5.7	STR to On	64
7.1.5.8	On to STD/SOff	66

	7.1.5.9	STD/SOff to On	68
7.2		82443BX Host Bridge Controller Power Sequencing	69
	7.2.1	Power Sequencing Requirements	69
	7.2.2	440BX AGPset Power Management	70
		7.2.2.1 System Power Modes	71
		7.2.2.2 System Power-up Sequencing	72
		7.2.2.3 Suspend Resume Protocols	73
		7.2.2.4 82443BX Suspend/Resume Sequences and Timing	77
		7.2.2.5 Suspend/Resume with PCIRST# Active	78
		7.2.2.6 Suspend/Resume with inactive PCIRST#, CPURST#	79
		7.2.2.7 Suspend/Resume with CPURST Active, PCIRST# Inactive	81
		7.2.2.8 Suspend/Resume from STD	82
7.3		EMC-2 Power Sequencing	82
	7.3.1	Voltage Regulator Control	82
	7.3.2	Voltage Signal Definition and Sequencing	83

Figures

1	EMC-2/440BX AGPset System Block Diagram	10
2	EDO DRAM - One On-board Bank, Two SODIMMs	17
3	EDO DRAM - Two SODIMMs	18
4	EDO DRAM - Three SODIMMs	19
5	SDRAM - One On-board Bank, Two SODIMMs	20
6	SDRAM - Two SODIMMs	21
7	SDRAM - Three SODIMMs	22
8	Clock Connections to the EMC-2 Module	25
9	Pinout for CK100-M Compatible Clock Synthesizer	26
10	Pinout for CKBF-M Compatible Clock Buffer	26
11	Timing Specifications Layout	27
12	EMC-2 Clocking Layout	29
13	General Clock Layout	30
14	On-board AGP Compliant Device Layout Guidelines	31
15	Signal Layout Recommendations	32
16	Pull-up Resistor Example	34
17	Clock Design Block Diagram	44
18	VREF Supply Schematic	46
19	PIIX4E Power Well Timings	51
20	RSMRST# and PWROK Timings	51
21	Suspend Well Power and RSMRST# Activated Signals	52
22	PCI Clock Stop Timing	53
23	PCI Clock Start Timing	53
24	Core Well Power and PWROK Activated Signals (RSMRST# Inactive before Core Well Power Applied)	54
25	Core Well Power and PWROK Activated Signals (Core Well Power Applied before RSMRST# Inactive)	55
26	Mechanical Off to On	57
27	On to POS	58
28	POS to On (with Processor and PCI Reset)	59
29	POS to On (with Processor Reset)	60

30	POS to On (No Reset)	61
31	On to STR	62
32	STR to On	64
33	On to STD/SOff	66
34	STD/SOff to On	68
35	REFVCC5 Supply Circuit Schematic	70
36	System Power-up Sequencing	72
37	Suspend/Resume with PCIRST# Active	79
38	Suspend/Resume with CPURST, PCIRST# Inactive	80
39	Suspend/Resume with Inactive PCIRST and Active CPURST#	81
40	Suspend/Resume from STD	82
41	Power On Sequence	84

Tables

1	Related Intel Documents	11
2	Related Specifications	11
3	Trace Lengths for the DRAM Interface	23
4	SODIMM DRAM Organization	23
5	System Examples for Supporting 64-Mbit SDRAM	24
6	Timing Specifications for Maximum and Minimum Clock Skews	28
7	EMC-2 Clocking Trace Layout Specifications	29
8	Clock Vendors	30
9	Data and Associated Strobe	31
10	Motherboard Recommendations	32
11	Control Signal Line Length Recommendations	32
12	Module Capacitive Decoupling Requirements	35
13	Clock and Test Signal Resistor Values	36
14	SDRAM and EDO Signal Resistor Values	36
15	EMC-2 Strapping Options	36
16	PCI Bus Signals Resistor Values	37
17	Sideband Signal Resistor Values	38
18	Power Management Signals Resistor Values	38
19	AGP Signals Resistor Values	39
20	PIIX4E Power Signal Pin Assignments	41
21	Clock and Test Signal Resistor Values	41
22	PCI Bus Signal Resistor Values	42
23	ISA/EIO Signal Resistor Values	43
24	Power Management Signal Resistor Values	44
25	IDE Interface Signal Resistor Values	45
26	Power State Decode	48
27	Resume Events Supported In Different Power States	48
28	Resume Event Programming Model	49
29	Power Plane Control	50
30	Power Plane Control Using SUS[C:A]# Signals	50
31	PIIX4E Power Well Timings	51
32	RSMRST# and PWROK Timing	51
33	Suspend Well Power and RSMRST# Timing	52



34 Core Well Power and PWROK Timing 54
35 Core Well Power and PWROK Timing 56
36 Mechanical Off to On Timing 57
37 On to POS Timing 58
38 POS to On Timing 59
39 POS to On (with Processor Reset) Timing 60
40 POS to On (No Reset) Timing 61
41 On to STR Timing 63
42 STR to On Timing 64
43 On to STD/SOff Timing 66
44 STD/SOff to On Timing 68
45 System-wide Low-power Modes 71
46 System Power-up Sequencing Timing 73
47 Suspend Resume Events And Activities 74
48 443BX Signal States During POS and STR Modes 75
49 Suspend/Resume Timing 77
50 Voltage Signal Definitions and Sequences 83

Revision History

Revision	Date	Notes
001	October 1998	First release of this document.

1.0 Introduction

This document provides design guidelines for developing systems based on the Pentium® II Processor Mobile Module: Embedded Module Connector 2 at 266 MHz. System board and memory subsystem design guidelines are included. Special design recommendations and concerns are presented. Likely design errors have been listed here in a checklist format. These are recommendations only. It is recommended that you perform your own simulations to meet design-specific requirements.

1.1 Key Terms

EMC-2 refers to the Embedded Module Connector-2. This module is identical to the Intel® Pentium® II Processor Mobile Module Connector (MMC-2). A complete description of this module is located in the *Intel® Pentium® II Processor Mobile Module: Mobile Module Connector 2 (MMC-2)* datasheet (<http://developer.intel.com/design/mobile/datashts>).

Intel 440BX AGPset refers to both the 82443 BX Host Bridge Controller and the 82371EB PCI ISA IDE Xcelerator.

82443BX refers to the Intel 82443BX Host Bridge Controller.

PIIX4E refers to the Intel 82371EB PCI ISA IDE Xcelerator.

Design Features are items that allow the designer to fully use the capabilities of the mobile Pentium® II processor and the Intel 440BX AGPset.

Design Checklists are items which provide recommendations for designing an EMC-2-based platform.

Design Considerations are items that should be considered but may not be applicable to your design.

1.2 Overview

EMC-2 module features are summarized below. Figure 1 is a block diagram of a typical EMC-2 system design.

- Full support for mobile Pentium® II processors with system bus frequencies of 66 MHz
- Intel 440BX AGPset
 - 82443BX Host Bridge Controller (443BX)
 - 82371EB PCI ISA IDE Accelerator (PIIX4E)
- 66 MHz memory interface: A wide range of DRAM support including:
 - 64-bit memory data interface plus 8 ECC bits and hardware scrubbing
 - 60 ns EDO DRAM and 66 MHz SDRAM support
 - 16 Mbit and 64 Mbit DRAM technologies
- 5 PCI masters
 - PCI Specification Rev 2.1 Compliant

- Accelerated Graphics Port (AGP) Slot:
 - AGP Interface Specification Revision 1.0 compliant
 - AGP - 66/133 MHz, 3.3-V device support
- Integrated IDE controller with Ultra DMA/33 support
 - PIO Mode 4 transfers
 - PCI IDE bus master support
- Integrated Universal Serial Bus (USB) controller with two USB ports
- Integrated System Power Management support

Figure 1. EMC-2/440BX AGPset System Block Diagram

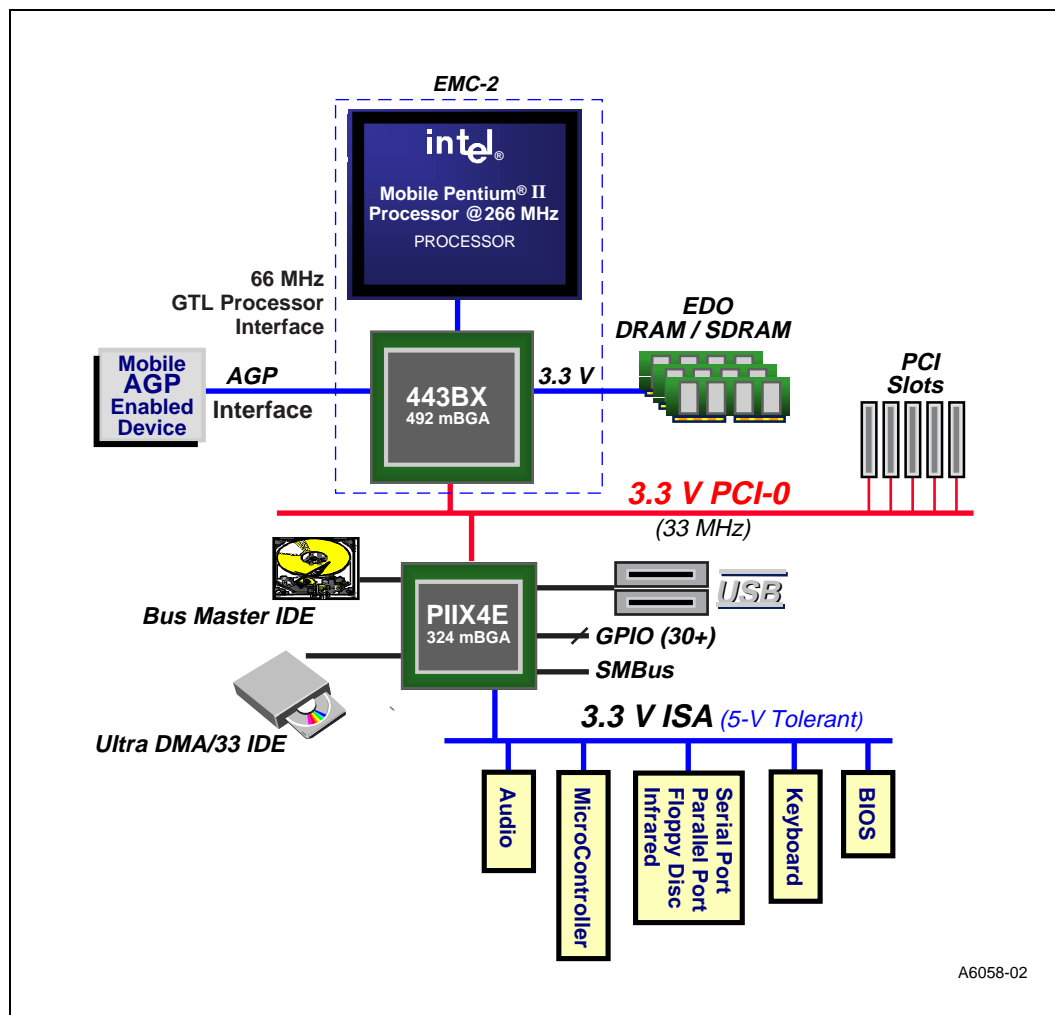

A6058-02

1.3 Related Documents

Table 1. Related Intel Documents

Document	Order Number
Intel® Pentium® II Processor Mobile Module (MMC-2) datasheet	243668
Mobile Pentium® II Processor Specification Update	243887
Intel® 440BX AGPset: 82443BX Host Bridge/Controller datasheet	290633
PIIX4 Universal Serial Bus Design Guide	NDA†
CK97 Clock Synthesizer Design Guidelines application note	243867
Intel® 82371EB PCI-to-ISA/IDE Xcelerator (PIIX4E) Specification Update	290635
Intel® 82371AB PCI-to-ISA/IDE Xcelerator (PIIX4) datasheet	290562
Intel® Architecture Software Developer's Manual, Volume 1; Basic Architecture	243190
Intel® Architecture Software Developer's Manual, Volume 2; Instruction Set Reference	243191
Intel® Architecture Software Developer's Manual, Volume 3; System Programming Guide	243192
Intel® Architecture MMX™ Technology Developer's Guide	243006
AP-485 Intel Processor Identification and the CPUID Instruction application note	241618
AP-585 Pentium® II Processor GTL + Guidelines application note	243330
AP-586 Pentium® II Processor Thermal Design Guidelines application note	243331
AP-587 Slot 1 Processor Power Distribution Guidelines application note	243332
AP-589 Slot 1 Processor EMI Overview application note	243334

† NDA documents are only available through an Intel Field Sales Representative.

Table 2. Related Specifications

Document	URL/Contact
PCI Local Bus Specification, Revision 2.1	http://www.pcisig.com/specs.html
Universal Serial Bus Specification, Revision 1.0	http://www.usb.org/usb/developers/index.html
AGP Interface Specification, Revision 1.0	http://www.agpforum.org/index.htm
AGP Platform Design Guide, Revision 1.1A	http://www.agpforum.org/index.htm
Information Technology – AT Attachment with Packet Interface Extension (ATA/ATAPI-4)	ftp://fission.dt.wdc.com/pub/standards/
System Management Bus Specification	http://www.sbs-forum.org/
66MHz Unbuffered SDRAM 64-bit (Non-ECC/Parity) 144-pin SO-DIMM Specification, Revision 1.0	Contact an Intel Field Sales Representative

2.0 Design Features

2.1 Mobile Pentium® II Processor

The mobile Pentium II processor is the first of the Pentium II processor family to be offered for the embedded platform. It is offered at 266 MHz with a PSB speed of 66 MHz. It consists of a mobile Pentium II processor core with an integrated second-level cache controller and a 64-bit high-performance host bus. The mobile Pentium II processor has a private second-level cache bus that allows a high-performance 64-bit wide cache subsystem to be gluelessly implemented using a Tag RAM and two BSRAM devices. The mobile Pentium II processor can cache up to 512 Mbytes of memory using 512 Kbytes of BSRAM. The private second level cache bus complements the host bus by providing critical data faster, improving performance, and reducing total system power consumption. The mobile Pentium II processor's 64-bit wide Low Power GTL+ host bus is compatible with the 440BX AGPset and provides a glueless, point-to-point interface for an I/O bridge and memory controller.

2.2 Intel® 440BX AGPset

The Intel® 440BX AGPset is based on the Pentium II processor architecture. It interfaces with the mobile Pentium II processor's system bus at 66 MHz. Along with its Host-to-PCI bridge interface, the 82443BX host bridge controller has been optimized with a 66 MHz SDRAM memory controller and data path unit. The 82443BX also features the Accelerated Graphics Port (AGP) interface. The 82443BX component includes the following functions and capabilities:

- 64-bit Low Power GTL+ based system data bus interface
- 32-bit system address bus support
- 64/72-bit main memory interface with optimized support for SDRAM
- 32-bit PCI bus interface with integrated PCI arbiter
- AGP interface with up to 133 MHz data transfer capability
- Extensive data buffering between all interfaces for high throughput and concurrent operations

Figure 1 shows a block diagram of a typical platform based on the 440BX AGPset. The 82443BX system bus interface supports a mobile Pentium II processor at a bus frequency of 66 MHz. The physical interface design is based on the Low Power GTL+ specification and is compatible with the Intel 440BX AGPset. The 440BX provides an optimized 72-bit DRAM interface (64-bit Data plus ECC). This interface supports 3.3-V DRAM technologies.

The 82443BX is designed to support the PIIX4E I/O bridge. The PIIX4E is a highly-integrated multifunctional component that supports the following functions and capabilities:

- PCI Revision 2.1 compliant PCI-to-ISA bridge with support for 33 MHz PCI operations
- ACPI Power Management support
- Enhanced DMA controller, interrupt controller and timer functions
- Integrated IDE controller with Ultra DMA/33 support
- USB host interface with support for two USB ports
- System Management Bus (SMB) with support for DIMM Serial Presence Detect

2.2.1 System Bus Interface

The 82443BX supports a maximum of 4 Gbytes of memory address space from the processor perspective. The largest address size is 32 bits. The 82443BX provides bus control signals and address paths for transfers between the processor bus, PCI bus, Accelerated Graphics Port and main memory. The 82443BX supports a 4-deep-in-order queue, which provides support for pipelining of up to four outstanding transaction requests on the system bus. The mobile Pentium® II processor supports a second-level cache size of 512 Kbytes with ECC. All cache-control logic is provided on the processor.

For system bus-to-PCI transfers, the addresses are either translated or directly forwarded on the PCI bus, depending on the PCI address space being accessed. When the access is to a PCI configuration space, the processor I/O cycle is mapped to a PCI configuration space cycle. When the access is to a PCI I/O or memory space, the processor address is passed without modification to the PCI bus. Certain memory address ranges are dedicated for a graphics memory address space. When this space or a portion of it is mapped to main DRAM, the address is translated by the AGP address remapping mechanism and the request is forwarded to the DRAM subsystem. A portion of the graphics aperture can be mapped on the AGP, and the corresponding system bus cycles accessing that range are forwarded to the AGP without any translation. The AGP address map defines other system bus cycles that are forwarded to the AGP.

2.2.2 DRAM Interface

The 82443BX integrates a main memory controller that supports a 64/72-bit DRAM interface which operates at 66 MHz. The integrated DRAM controller features include:

- 3.3-V interface
- Support for up to three double-sided SODIMMs
 - 8 Mbytes to 48 Mbytes using 16-Mbit technology
 - 192 Mbytes using 64-Mbit technology
- Support for ECC with hardware scrubbing

2.2.3 Accelerated Graphics Port Interface

The 82443BX supports an AGP interface. The AGP interface has a maximum theoretical transfer rate of ~532 Mbytes/s.

2.2.4 PCI Interface

The 82443BX PCI interface operates at 33 MHz, is Revision 2.1 compliant, and supports up to five external PCI bus masters in addition to the PIIX4E I/O bridge. The PCI interface is only 3.3-V. If the developer requires a 5-V interface, a level shifter implementation is recommended.

2.2.5 System Clocking

The 82443BX operates the system bus interface at 66 MHz, the PCI bus at 33 MHz and the AGP at a transfer rate of 66/133 MHz. The 82443BX clocking scheme uses an external clock synthesizer that produces reference clocks for the system bus and PCI interfaces. The 82443BX generates the AGP and DRAM clock signals. Please refer to the *CK97 Clock Synthesizer/Driver Specification* (order number 243867).

2.3 PCI ISA IDE Xcelerator (PIIX4E)

The PCI ISA IDE Xcelerator (PIIX4E) is a multi-function PCI device that implements a PCI-to-ISA bridge function, a PCI IDE function, a Universal Serial Bus host/hub function, and an Enhanced Power Management function. Because it is a PCI-to-ISA bridge, the PIIX4E integrates many common I/O functions found in ISA-based PC systems; a seven channel DMA Controller, two 82C59 Interrupt Controllers, an 8254 Timer/Counter, and a Real Time Clock. In addition to DMA Compatible transfers, each DMA channel also supports Type F transfers.

The PIIX4E contains full support for PC/PCI and Distributed DMA protocols that implement PCI-based DMA. The Interrupt Controller has edge or level sensitive programmable inputs. Chip select decoding is provided for a BIOS, Real Time Clock, Keyboard Controller, second external microcontroller, and two Programmable Chip Selects. The PIIX4E provides full Plug-and-Play compatibility. The PIIX4E can be configured as a subtractive decode bridge or as a positive decode bridge.

The PIIX4E supports two IDE connectors. This provides an interface for IDE/EIDE hard disks and CD-ROMs. Up to four IDE devices can be supported in Bus Master mode. The PIIX4E contains support for Ultra DMA/33 compatible synchronous DMA devices.

The PIIX4E contains a Universal Serial Bus (USB) host controller that is Universal Host Controller Interface (UHCI) compatible. The host controller's root hub has two programmable USB ports.

The PIIX4E supports Enhanced Power Management, including full clock control, device management for up to 14 devices, and suspend and resume logic with Power On Suspend, Suspend to RAM, or Suspend to Disk. The PIIX4E fully supports operating-system-directed power management according to the Advanced Configuration and Power Interface (ACPI) specification. The PIIX4E integrates both a System Management bus (SMBus) host and slave interface for serial communication with other devices.

For more information on the PIIX4E, please refer to the *82371AB PCI-to-ISA/IDE Xcelerator (PIIX4)* datasheet (order number 290562) and the *82371EB PCI-to-ISA/IDE Xcelerator (PIIX4E) Specification Update* (order number 290635).

3.0 Memory Guidelines

This section lists guidelines to be followed when routing the signal traces for the board design. The order in which signals are routed first and last will vary from designer to designer. Some designers prefer routing the clock signals first, while others prefer routing the high-speed bus signals first. Either order can be used, as long as the guidelines listed here are followed. When the guidelines listed here are not followed, it is very important to simulate the design. Even when the guidelines are followed, it is recommended that you simulate these signals for proper signal integrity, flight time and cross talk.

3.1 DRAM Interface Overview

The 82443BX integrates a main memory DRAM controller that supports a 64-bit DRAM array for embedded environments. The DRAM types supported are Synchronous (SDRAM) and Extended Data Out (EDO). The 82443BX does not support a mixture of SDRAM and EDO memory. The

82443BX DRAM interface runs at 66 MHz. The DRAM controller interface is fully configurable through a set of control registers. Complete descriptions of these registers are given in the *Intel® 440BX AGPset: 82443BX Host Bridge/Controller* datasheet.

The 443BX supports industry standard 64-bit wide 144-pin SODIMM modules with SDRAM or EDO DRAM devices. Both symmetric and asymmetric addressing is supported. For write operations of less than a Qword in size, the 443BX will either perform a byte-wide write cycle (non-ECC protected configuration) or a read-modify-write cycle by merging the write data on a byte basis with the previously read data (ECC or error correction configurations). The 82443BX requires 60 ns EDO DRAMs or SDRAM with CAS latency of 2 (CL2), and supports 1-and 2-row SODIMMs. The 82443BX provides refresh functionality with programmable rates (normal DRAM rate is 1 refresh/15.6 μ s). When using SDRAM the 82443BX can be configured via the paging policy register to keep multiple pages open within the memory array. Pages can be kept open in all rows of memory. When using two bank SDRAM devices in a particular row, up to two pages can be kept open within that row.

The DRAM interface of the 82443BX is configured by the DRAM control registers, DRAM timing register, SDRAM control register, bits in the NBXCFG register and the eight DRAM row boundary (DRB) registers. The DRAM configuration registers control the DRAM interface to select EDO or SDRAM, RAS timing, and CAS rates. The eight DRB registers define the size of each row in the memory array, enabling the 82443BX to assert the proper CSA[7:0]#, CSB[7:0]# pair for accesses to the array.

3.1.1 Pin Groups

The 82443BX has multiple copies of many of the signals interfacing to memory. However, the EMC-2/440BX AGPset only supports a single copy of the memory signals. See “Single Set DRAM Interface” on page 16 for more information. The interface consists of the following pins:

Multiple copies:

MAA[13:0], MAB[12:11,9:0]# and MAB[13, 10]
 CSA[7:0]#, CSB[7:0]#
 SRASA#, SRASB#
 SCASA#, SCASB#
 WEA#, WEB#
 DQMA[7:0], DQMB[5:1]

Single copies:

CKE[5:0] (for three SODIMM configuration)
 MD[63:0]
 MECC[7:0]
 GCKE (for four DIMM configuration)
 FENA (FET switch control for four DIMM configuration)

The CSA[7:0]#, CSB[7:0]# pins function as RAS# pins in the case of EDO DRAMs. The DQM pins function as CAS# pins in the case of EDO DRAMs. Two CS# lines are provided per row. These are functionally equivalent. The extra copy is provided for loading reasons. The two SRAS#, SCAS# and WE# pins are also functionally equivalent and each copy drives two rows of DRAM. Most pins use programmable strength output buffers. When a row contains 16-Mbit SDRAMs, MAA11 and MAB11# function as Bank Select lines. When a row contains 64-Mbit SDRAMs, MAA[12:0], MAB[12:11] function as Bank Addresses (BA[1:0], or Bank Selects). If the design

does not support ECC, you may leave MECC[7:0] unconnected. When the design supports ECC, perform simulations to determine which buffer strength is needed for loading requirements. This may require a BIOS change.

3.1.2 Single Set DRAM Interface

The following two sections explain which signals are used in embedded platforms. Note that MAB[13,10] are not active low because these address bits are used to define various SDRAM commands.

3.1.2.1 EDO DRAM

Single copies used:

MAB[12:11,9:0]# and MAB[13,10]
 MD[63:0]
 MECC[7:0]
 RASA[5:0]#
 CASA[7:0]#
 WEA#

3.1.2.2 SDRAM

Single copies used:

MAB[12:11,9:0]# and MAB[13,10]
 MD[63:0]
 MECC[7:0]
 CSA[5:0]#
 DQMA[7:0]
 CKE[5:0]
 SRASA#
 SCASA#
 WEA#

3.2 DRAM Layout Guidelines

Note: The following DRAM layout guidelines are intended for use with the 266 MHz EMC-2 platforms that will use *only* 66 MHz Host/SDRAM clock frequencies.

- The DRAM expansion socket for embedded applications is the 144-pin SODIMM.
- MAB[11]# should be connected to pin 106 of the SODIMM connector.
- MAB[12]# should be connected to pin 70 and pin 110 of the SODIMM connector.
- MAB[13] should be connected to pin 72 and pin 112 of the SODIMM connector.
- For onboard 64-Mbit SDRAM devices on the motherboard, MAB[11]# should be connected to A13/BA0 on the SDRAM device, and MAB[13] should be connected to A11 on the SDRAM device.

- The memory data bit traces may be byte-swapped to simplify board routing and minimize trace lengths. This should also be done for the data bits within the byte channel.
- Board impedance should be $55 \Omega \pm 15\%$.
- All resistors should be within 5% tolerance.
- Trace widths for memory signals should be 5 mil.
- Populate the furthest SODIMM first to avoid stub reflections.
- Any onboard memory should be put further away from the EMC-2 module than the SODIMM connectors.
- Place the on board DRAM connector, SODIMM connector, and EMC-2 connector as near to each other as possible.

3.2.1 SODIMM Connection - EDO DRAMs

Figures 2 and 3 show how to route the EMC-2/440BX DRAM interface to EDO DRAM.

Figure 2. EDO DRAM - One On-board Bank, Two SODIMMs

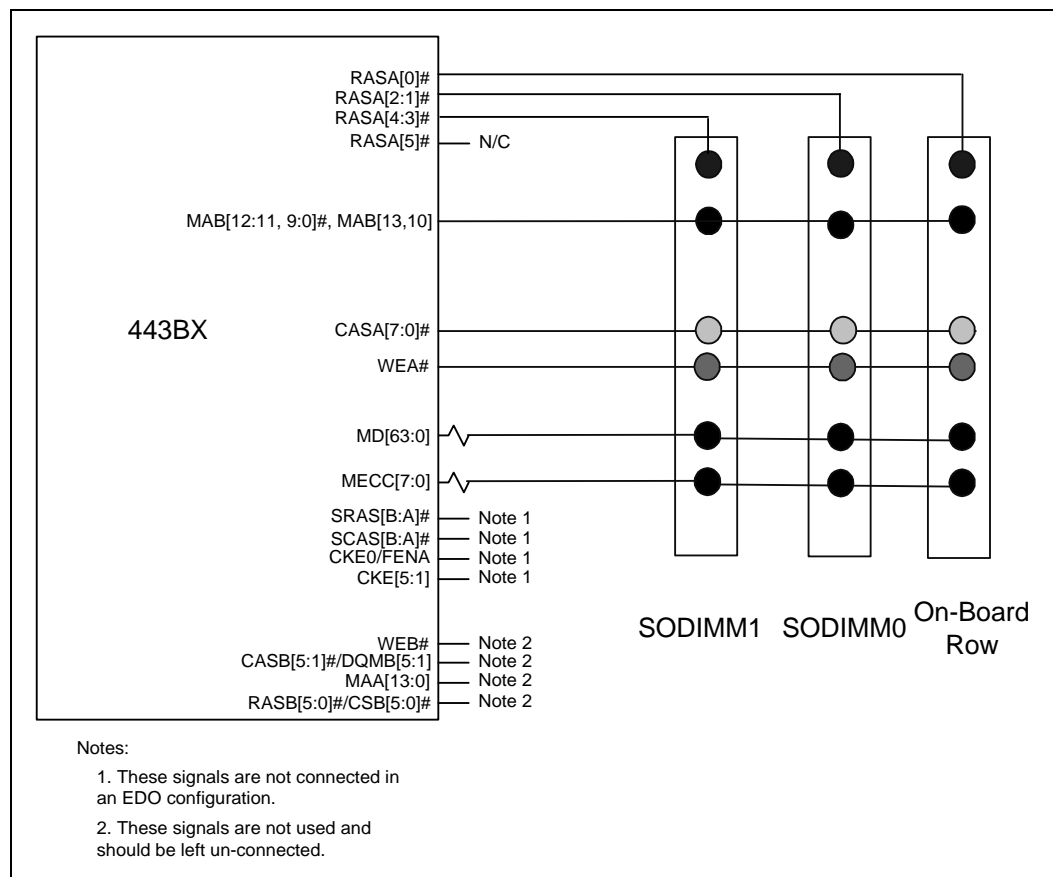

Figure 3. EDO DRAM - Two SODIMMs

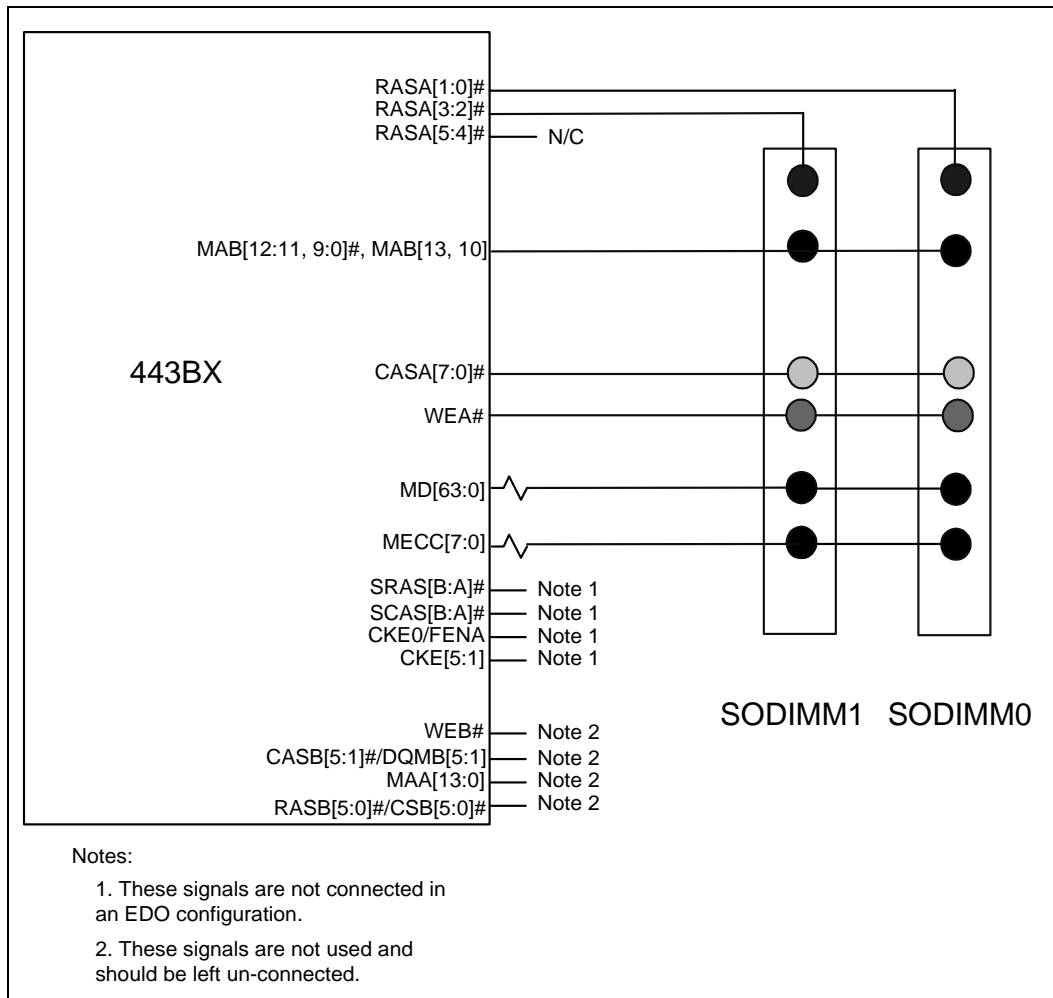
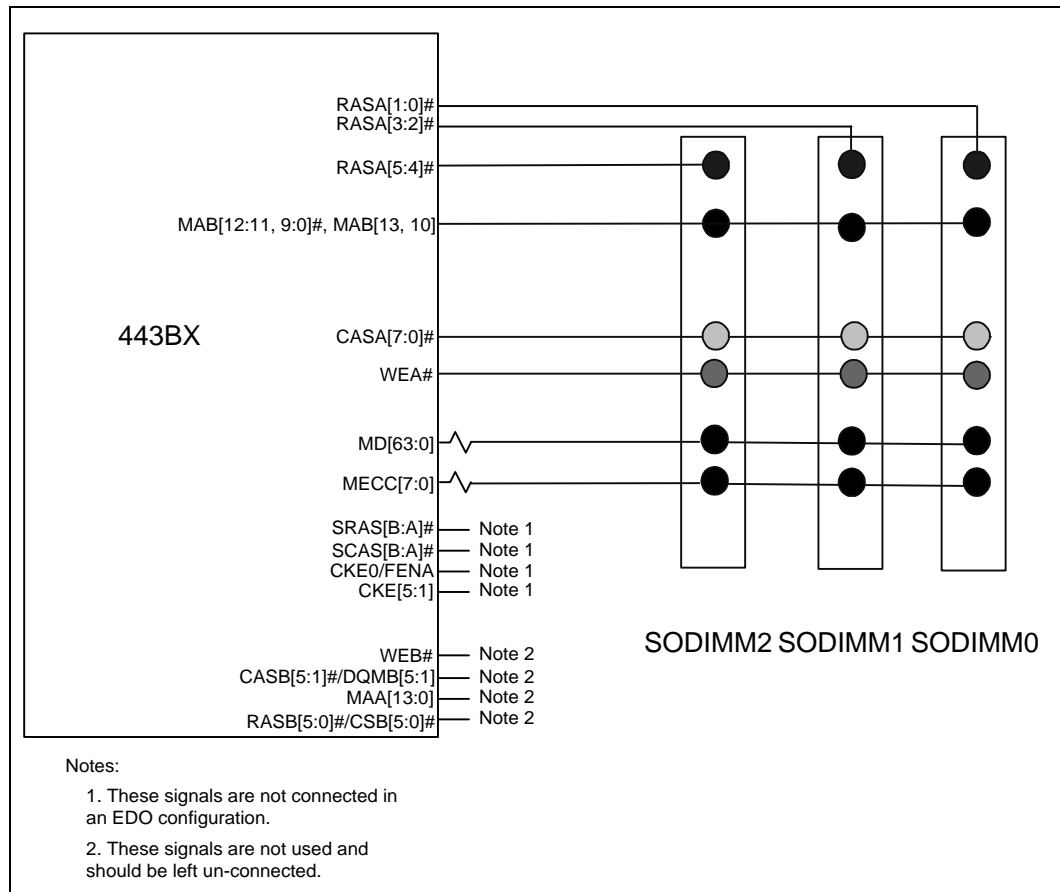

Figure 4. EDO DRAM - Three SODIMMs



3.2.2 SODIMM Connection - SDRAM

Figures 5 and 6 show how to route the EMC-2/440BX DRAM interface to SDRAM.

Figure 5. SDRAM - One On-board Bank, Two SODIMMs

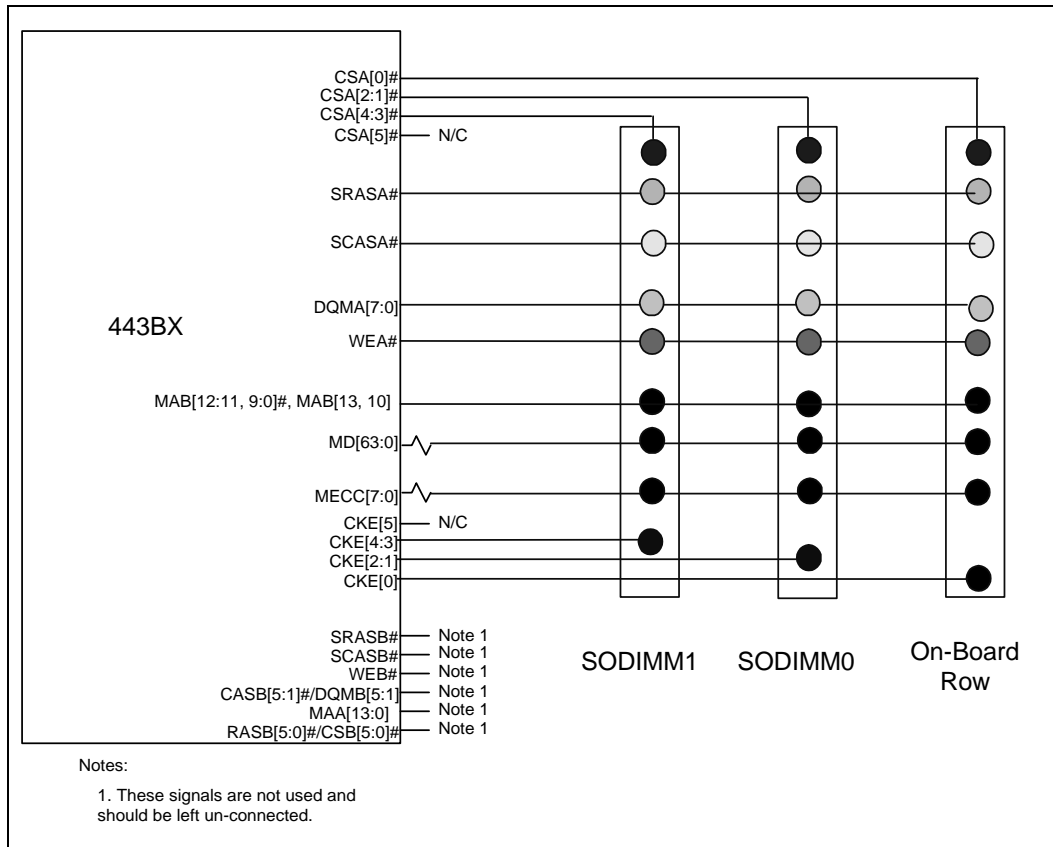

Figure 6. SDRAM - Two SODIMMs

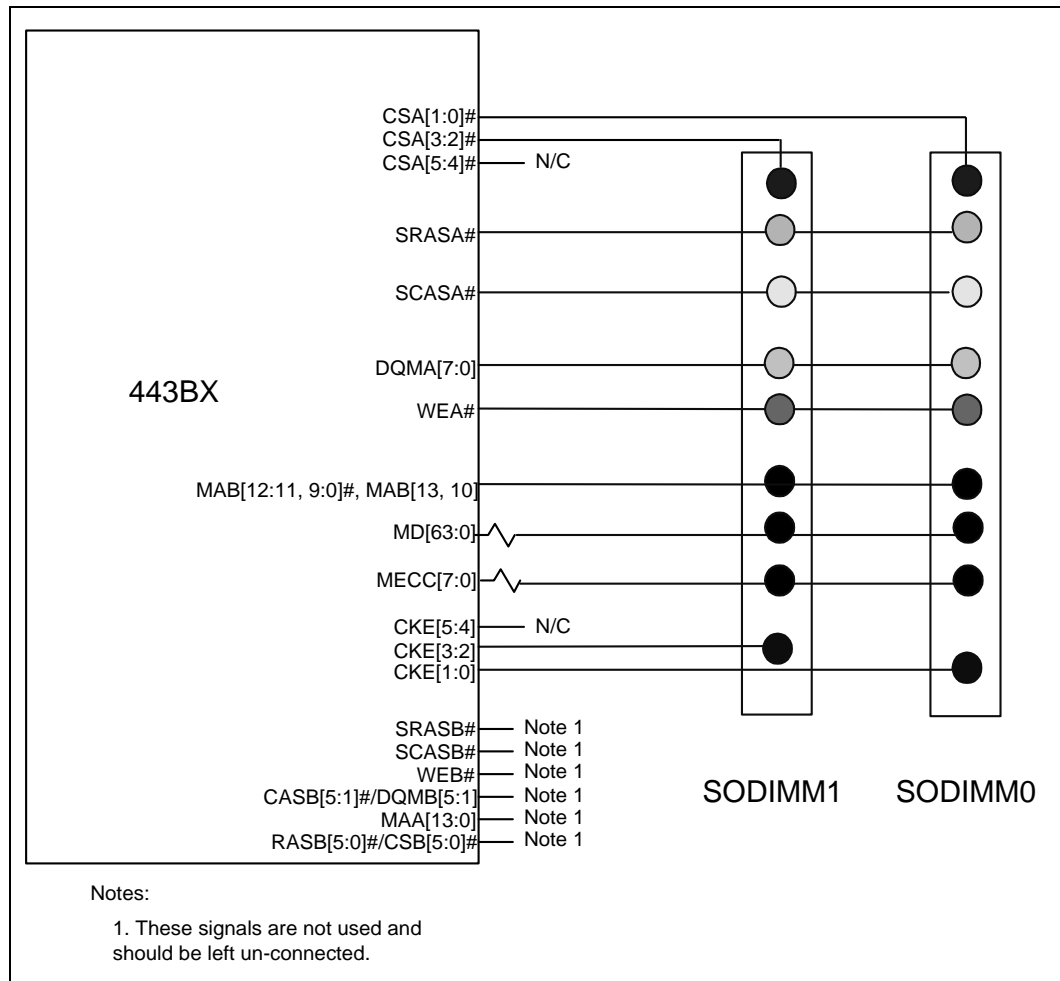
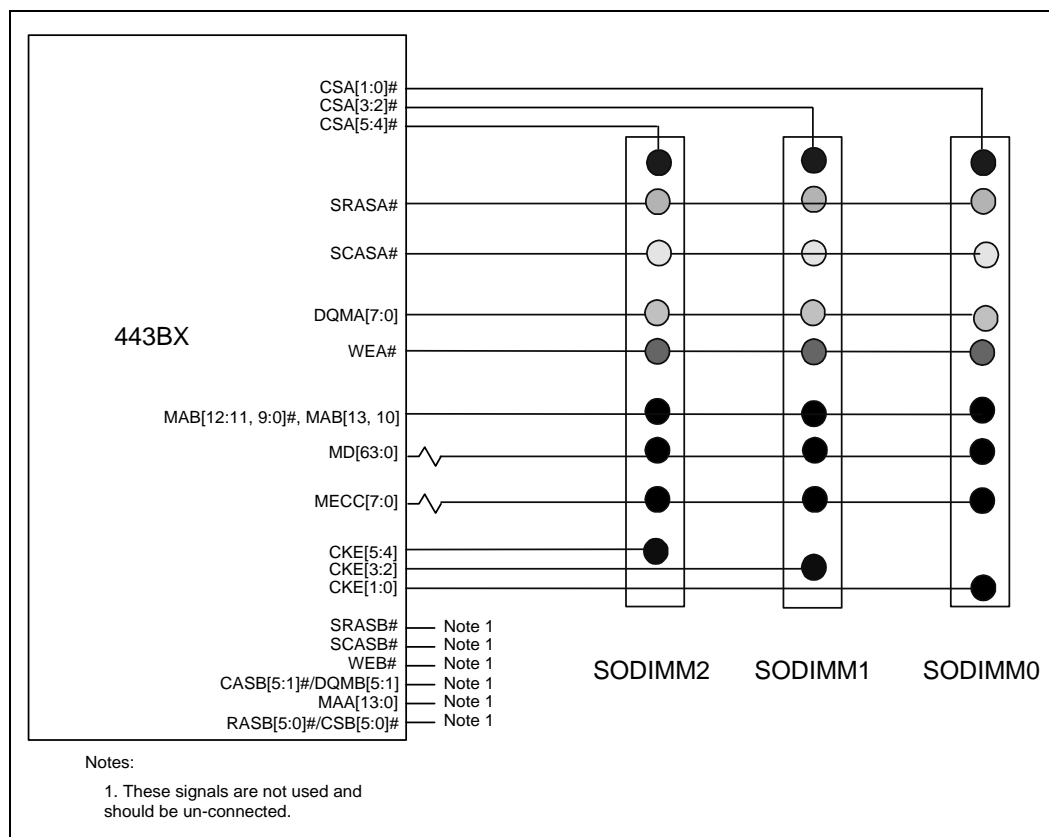

Figure 7. SDRAM - Three SODIMMs



3.2.3 Memory Trace Lengths for Module Design

Note: The following DRAM layout guidelines are intended for use with the 266 MHz EMC-2 platforms that use *only* 66 MHz Host/SDRAM clock frequencies.

Table 3 provides the minimum and maximum trace lengths to the SODIMM connector for each signal group (excluding clock) for each design. For the trace lengths of clocks, see “Clocking Guidelines” on page 25.

For memory configurations with on-board memory devices, signal traces should be routed as if there were a “phantom” connector on the board. The designer should follow the routing guidelines from the *66MHz Unbuffered SDRAM 64-bit (Non-ECC/Parity) 144-pin SO-DIMM Specification*, Revision 1.0, for the memory signals from the “phantom” connector to the on-board memory devices (refer to Table 2 on page 11). In other words, route the memory channel from the 82443BX to the position that SODIMM0 would occupy in your design following the given constraints, and route from that point onward according to the *66MHz Unbuffered SDRAM 64-bit (Non-ECC/Parity) 144-pin SO-DIMM Specification*.

Table 3. Trace Lengths for the DRAM Interface

Signal	Min. Length	Max. Length		Resistor (on System Electronics Board)
MAB[13:0]x, WEA#, SRASA#, SCASA#	0 inch	8.0 inch	203.2 mm	NONE
CKE[5:0]	0 inch	9.0 inch	228.6 mm	NONE
CSA/RASA[5:0]#	0 inch	9.0 inch	228.6 mm	NONE
CASA[7:0]#/DQMA[7:0]#	0 inch	9.0 inch	228.6 mm	NONE
MD[63:0], MECC[7:0]	0 inch	8.0 inch	203.2 mm	18 Ω ± 5%

3.3 SODIMM DRAM Organization

The 144-pin SODIMM (1” height) has a maximum capacity of eight devices and provides the following configuration possibilities (see Table 4) for SDRAM or EDO.

Table 4. SODIMM DRAM Organization

Technology	SODIMM Organization	Component Organization	Devices per Row	Mbyte per SODIMM
16 Mbit	1 M x 64 / S	1 M x 16	4	8 Mbyte
	2 M x 64 / D	1 M x 16	4	16 Mbyte
64 Mbit	2 M x 64 / S	2 M x 8	8	16 Mbyte
	2 M x 64 / S	2 M x 32	2	16 Mbyte
	4 M x 64 / D	2 M x 32	2	32 Mbyte
	4 M x 64 / S	4 M x 16	4	32 Mbyte
	8 M x 64 / D	4 M x 16	4	64 Mbyte
	8 M x 64 / S	8 M x 8	8	64 Mbyte

NOTE: “S” denotes single-sided SODIMMs. “D” denotes double-sided SODIMMs.

3.3.1 64-Mbit SDRAM System Examples

Table 9 lists five system examples. Each example is based on using three SODIMM sockets or one on-board DRAM and two SODIMM sockets. The terms used in Table 9 are defined below:

144 SODIMM: Number of SODIMM sockets plus on-board DRAM
 Row: RAS[5:0]# or CS[5:0]# connection.
 Technology: DRAM technology 16 Mbit, 64 Mbit
 Density/Width: DRAM configuration 16 Mbit: 2 M x 8, or 1 M x 16
 64 Mbit: 8 M x 8, 4 M x 16, or 2 M x 32
 # Devices/Row: Number of DRAM components per row.

Table 5. System Examples for Supporting 64-Mbit SDRAM

144 SODIMM	Row	Technology	Density x Width	# Devices/Row	Mbytes per SODIMM
Example #1					
#1 or on-board	0	16 Mbit	2 M x 8	8	16 Mbytes
#2	1	16 Mbit	1 M x 16	4	8 Mbytes
	2	16 Mbit	1 M x 16	4	8 Mbytes
#3	3	16 Mbit	2 M x 8	8	16 Mbytes
Total	4			24	48 Mbytes
Example #2					
#1 or on-board	0	16 Mbit	2 M x 8	8	16 Mbytes
#2	1	16 Mbit	2 M x 8	8	16 Mbytes
#3	2	16 Mbit	2 M x 8	8	16 Mbytes
Total	3			24	48 Mbytes
Example #3					
#1 or on-board	0	16 Mbit	2 M x 8	8	16 Mbytes
#2	1	64 Mbit	8 M x 8	8	64 Mbytes
#3	2	64 Mbit	4 M x 16	4	32 Mbytes
Total	3			20	112 Mbytes
Example #4					
#1 or on-board	0	64 Mbit	8 M x 8	8	64 Mbytes
#2	1	64 Mbit	8 M x 8	8	64 Mbytes
#3	2	64 Mbit	8 M x 8	8	64 Mbytes
Total	3			24	192 Mbytes

4.0 Clocking Guidelines

This section lists guidelines to be followed when routing the signal traces for the board design. The order in which signals are routed will vary from designer to designer. Some designers prefer routing all of the clock signals first, while others prefer routing the high-speed bus signals first. Either order can be used, as long as the guidelines listed here are followed. When the guidelines listed here are not followed, it is very important to simulate the design. Even when the guidelines are followed, it is recommended that you simulate signals for proper signal integrity, flight time and cross talk.

4.1 Clocking System Overview

This section provides guidelines and application information for clock layout in an EMC-2/440BX AGPset system. These guidelines are based on the HCLK, PCICLK and SDRAMCLK requirements and should be implemented along with the application instructions supplied by your clock chip vendor. Figure 8 shows the clock synthesizer connection to the processor, 443BX, and SDRAM when using an EMC-2 module.

Figure 8. Clock Connections to the EMC-2 Module

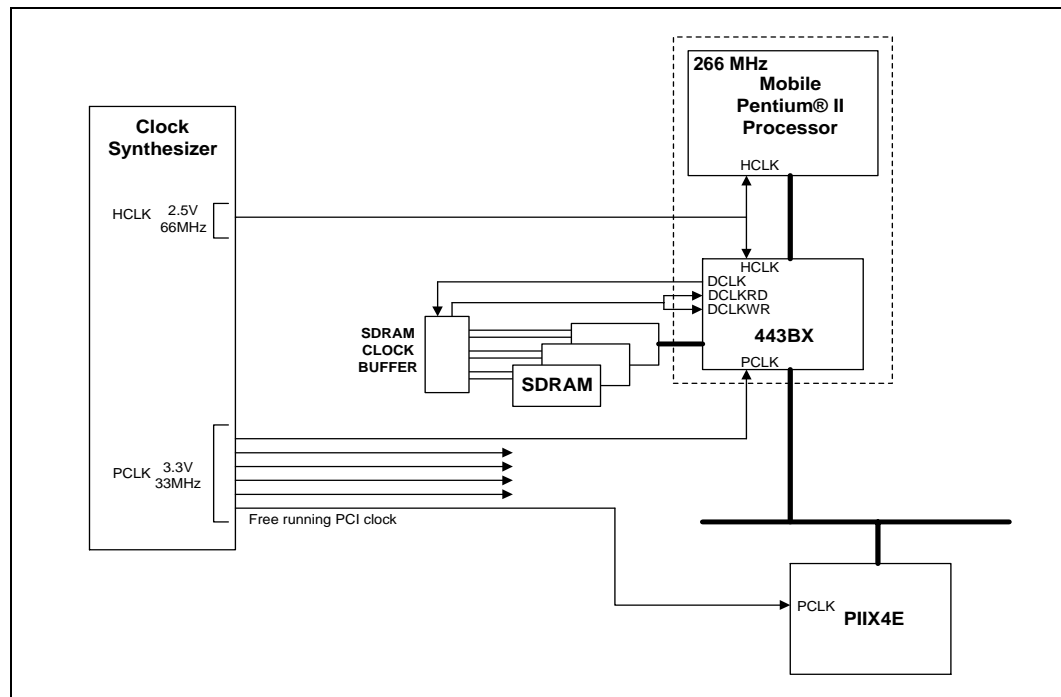

4.2 Clock Synthesizer Pinout and Specifications

A clock synthesizer that meets the *CK97 Clock Synthesizer Design Guidelines* (order number 243867) will meet the requirement for an EMC-2/440BX AGPset-based system. Table 8 on page 30 lists clock vendors that provide clock synthesizers which meet the *CK97 Clock Synthesizer Design Guidelines*.

Note: The CK100-M compatible clock synthesizer operates in multi-voltage mode. The processor clocks operate at 66 MHz at 2.5 V, and the PCI clocks operate at 33 MHz at 3.3 V. The CKBF-M compatible clock buffer provides clocks for SDRAM operating at 66 MHz at 3.3 V.

Figure 9. Pinout for CK100-M Compatible Clock Synthesizer

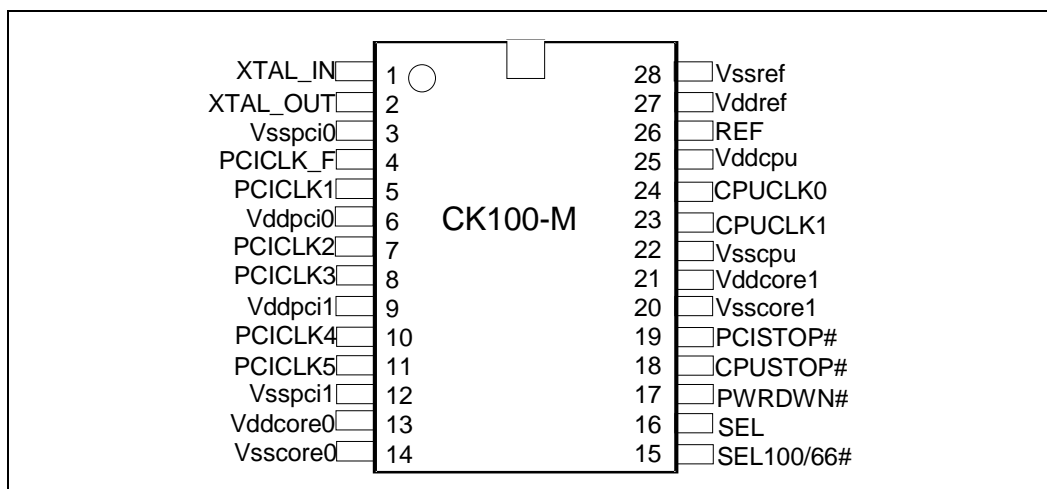
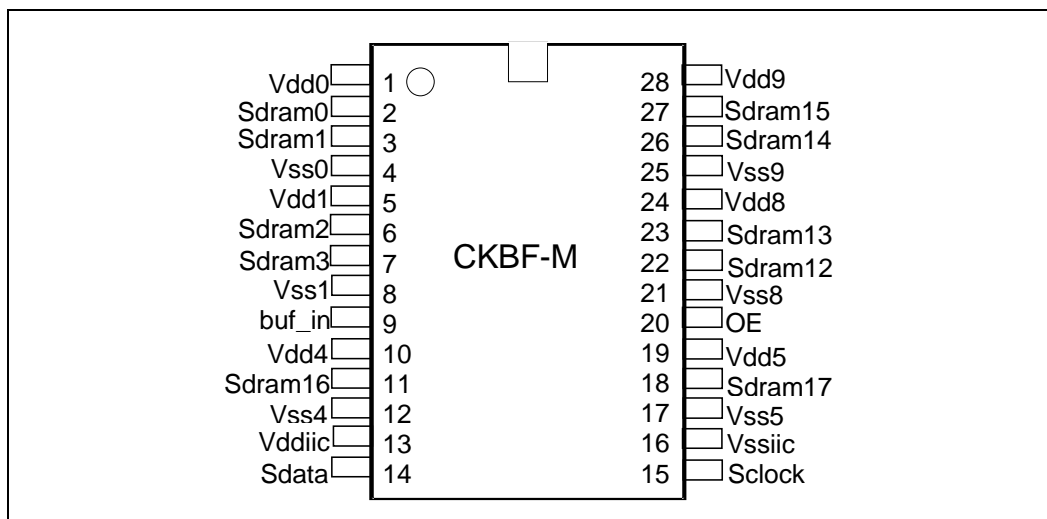

Figure 10. Pinout for CKBF-M Compatible Clock Buffer



4.3 Timing Guidelines

Trace lengths should be matched within clock signal groups to minimize skew between copies of the clocks. This applies to the HCLK-to-HCLK and the PCICLK-to-PCICLK clock trace lengths.

Figure 11. Timing Specifications Layout

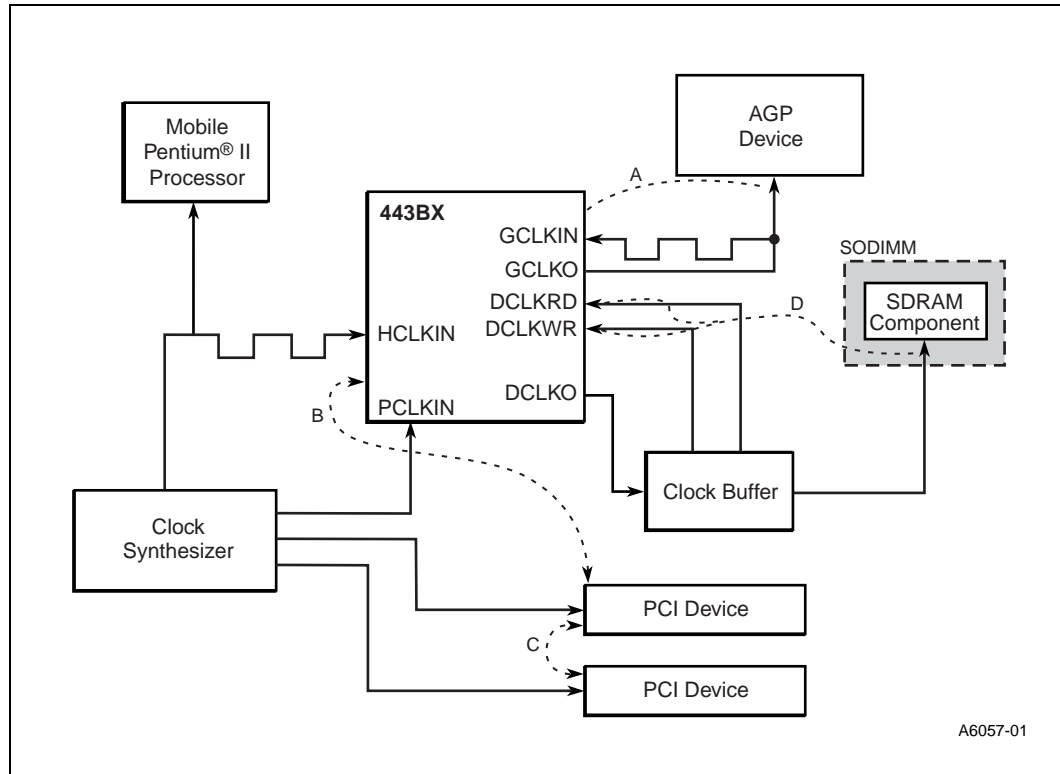

Figure 11 shows a simplified clocking layout for the timing specifications. The recommended trace lengths are given in the Note on page 28. See Table 6 for the clock skews.

Table 6. Timing Specifications for Maximum and Minimum Clock Skews

Symbol	Description	CK100-M Pin-to-Pin	Boards	Total
A	AGP device (GCLK) to 440BX AGPset (GCLKIN) skew	N/A	100 ps (max) - 100 ps (min)	100 ps (max) - 100 ps (min)
B	440BX AGPset (HCLK) to PCI (PCLK) skew	4.0 ns (max.) 1 1.5 ns (min.)	1.0 ns (max.) 0 ns (min.)	5.0 ns (max.) 1.5 ns (min.)
C	PCI (PCLK) to PCI (PCLK) skew	500 ps (max) - 500 ps (min)	1.5 ns (max) -1.5 ns (min)	2.0 ns (max) - 2.0 ns (min)
D	DCLKWR to SDRAM (SCLK) skew	250 ps (max) -250 ps (min)	380 ps (max) 2 - 380 ps (min) 2	630 ps (max) - 630 ps (min)

NOTES:

1. The 82443BX PCICLK input should lag its HCLK input by a minimum of 1.5 ns to a maximum of 4.0 ns at the pins of the CK100-M device. An integrated buffer offers the best control over these output-to-output drive skews.
2. This skew allowance includes ± 280 ps for I/O capacitance and SODIMM routing variation. Motherboards should allow for no more than ± 100 ps contribution to the total skew.

Note: Clock period, jitter, offset and skew are measured on the rising edge of the clock signals at 1.25-V for the 2.5-V clocks and at 1.5-V for the 3.3-V clocks.

4.4 Clock Layout Guidelines

- Series matching resistors are required.
 - Resistor Value: See Table 7.
 - Placement: As near as possible to the driver pin (less than 1")
- A PCLK that is used for a PCI socket should be a point-to-point connection and should not be shared with another load.
- When designing with an expansion connector, remember to account for the PCICLK trace length in the docking station.
- Route all clocks on internal layers to provide better trace delay consistency and EMI containment.
- Board impedance should be $55 \Omega \pm 15\%$.
- Use discrete resistors on HCLK signals coming from CK100-M.
- Minimize the use of vias in clock signals.
- All clocks should have 1:2 width-to-spacing ratio.
- CKBF-M should be on the V_3 rail and CK100-M should be on the V_3S rail (see “Power and Ground Pins” on page 34 for a description of these rails).

Figure 12. EMC-2 Clocking Layout

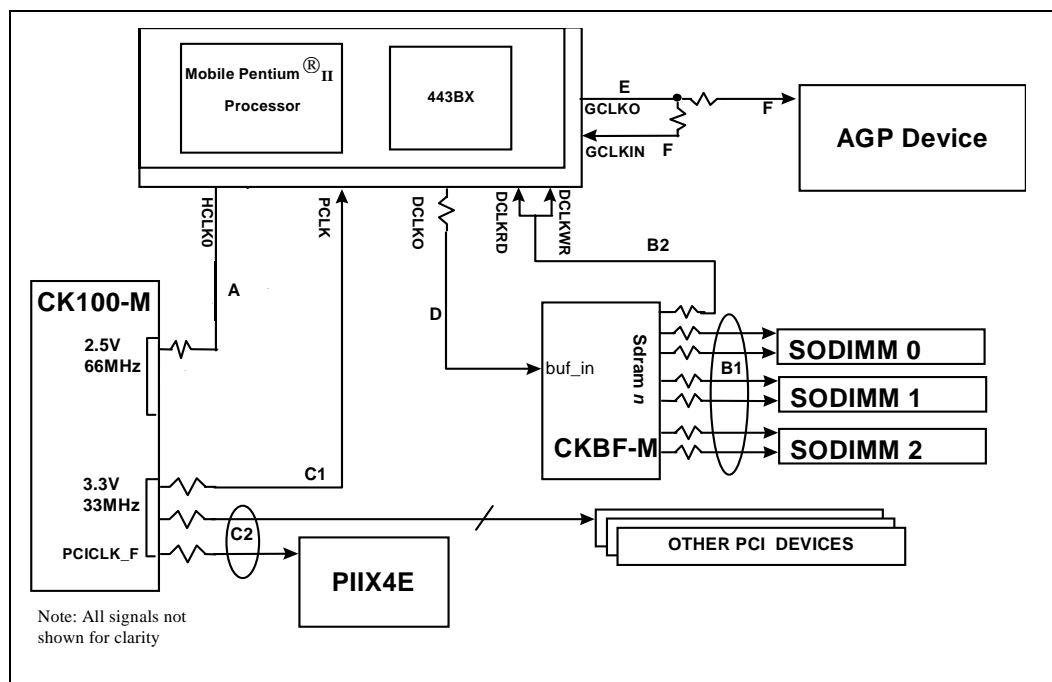

Table 7. EMC-2 Clocking Trace Layout Specifications

Variable	Trace Width	Minimum Trace Length	Maximum Trace Length	Tolerance (Note 1)	Resistor Value
A (Notes 3)	10 mil	0 inch (0 mm)	4.0 inch (101.6 mm)	± 0.1 inch (± 2.54 mm)	18 Ω ± 5%
B ₁ (Notes 2, 3)	5 mil	0 inch (0 mm)	4.0 inch (101.6 mm)	± 0.1 inch (± 2.54 mm)	18 Ω ± 5%
B ₂	5 mil	B ₁ +2.4 inch (B ₁ +60.9 mm)	B ₁ +2.6 inch (B ₁ +66 mm)		18 Ω ± 5%
C ₁	5 mil	A	A+4 inch (A+101.6 mm)		33 Ω ± 5%
C ₂	5 mil	C ₁	C ₁	± 4.5 inch (± 114.3mm)	33 Ω ± 5%
D	5 mil	0 inch (0 mm)	4.0 inch (101.6 mm)		18 Ω ± 5%
E	10 mil	0 inch (0 mm)	1 inch (25.4 mm)		None
F	5 mil	0 inch (0 mm)	8.5 inch (215.9 mm)		18 Ω ± 5%

NOTES:

1. "Tolerance" refers to the allowed difference in length between multiple traces sharing the same variable name.
2. For platforms with on-board memory devices, clock traces should be routed as if there were a "phantom" connector on the board. The designer should follow the routing guidelines in the *66 MHz Unbuffered SDRAM 64-bit Non-ECC/Parity 144-pin SODIMM Specification* for the clock signals from the "phantom" connector to the on-board memory devices. In other words, route the clock trace to the position that SODIMM0 would occupy following the constraints given above, and route from that point onward according to the *66 MHz Unbuffered SDRAM 64-bit Non-ECC/Parity 144-pin SODIMM Specification*.
3. These layout guidelines are intended only for platforms in which the Host/SDRAM clocks run at 66 MHz.

4.5 Optional Clock Layout

Figure 13. General Clock Layout

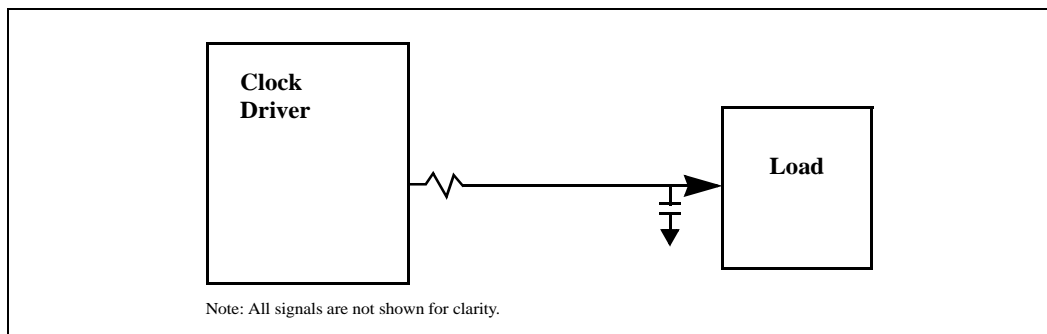

This optional layout implementation is suggested to accommodate clock tuning, HCLK & PCICLK from CK100-M and SCLK from CKBF-M. This will allow the designer to tune the individual clock signals to minimize EMI and allow for variations in impedance, skew and loading.

The variables to be considered include:

- Variation in actual device load
- Line and load impedance variation
- Driver output impedance
- Vendor variation

The stub to the capacitor must be minimized. The maximum stub length on a clock trace is < 0.5 inch. The capacitor should be placed as close as possible to the load. Refer to the specific clock vendors for layout and termination guidelines.

4.6 Clock Vendors

Table 8. Clock Vendors

Vendor Name	Address
IC Works, Inc.	3725 North First Street San Jose, CA 95134 (408) 922-0202
International Microcircuits, Inc.	525 Los Coches Street Milpitas, CA 95035 (408) 263-6300
Integrated Circuit Systems, Inc.	1271 Parkmoor Avenue San Jose, CA 95126-3448 (408) 925-9493
Cypress Semiconductor	12020 113th Ave. Northeast Kirkland, WA 98034 (425) 398-3400

5.0 82443BX AGP Interface for EMC-2 Design

This section lists guidelines to be followed when routing the signal traces for the board design. Even when the guidelines are followed, it is recommended that you simulate as many signals as possible for proper signal integrity and cross talk. See Section 6.2.10, “AGP Signals” on page 38 for AGP pull-up requirements. See Section 4.0, “Clocking Guidelines” on page 25 for AGP clocking information.

5.1 Layout and Routing Guidelines

For the definition of AGP interface functionality (protocols, rules and signaling mechanisms, and the platform level aspects of AGP functionality), refer to the latest *AGP Interface Specification* and *AGP Platform Design Guide*. This document focuses only on specific 440BX platform recommendations for the AGP interface.

Throughout this section the term “data” refers to G_AD[31:0], G_C/BE[3:0]# and SBA[7:0]. The term “strobe” refers to AD_STB[B:A] and SB_STB. When the term “data” is used, it is referring to one of three groups of data as seen in Table 9. When the term “strobe” is used it is referring to one of the three strobes as it relates to the data in its associated group.

Table 9. Data and Associated Strobe

Data	Associated Strobe
G_AD[15:0] and G_C/BE[1:0]#	AD_STBA
G_AD[31:16] and G_C/BE[3:2]#	AD_STBB
SBA[7:0]	SB_STB

5.1.1 On-board AGP Compliant Device Layout Guidelines

Longer trace lengths require a greater amount of spacing between traces in order to reduce crosstalk. When using 1:2 spacing, maximum trace length of data lines is 9.5 inches. The line length mismatch is 0.5 inches. The strobe is the longest trace of the group. This restricts the maximum trace length of data lines to less than 4.5 inches for a 1:1 trace spacing. The strobe requires a 1:2 trace spacing. Trace length guidelines given in this section do not reflect signal integrity and EMI. It is recommended that you simulate the routes to ensure that signal quality requirements are met.

Figure 14. On-board AGP Compliant Device Layout Guidelines

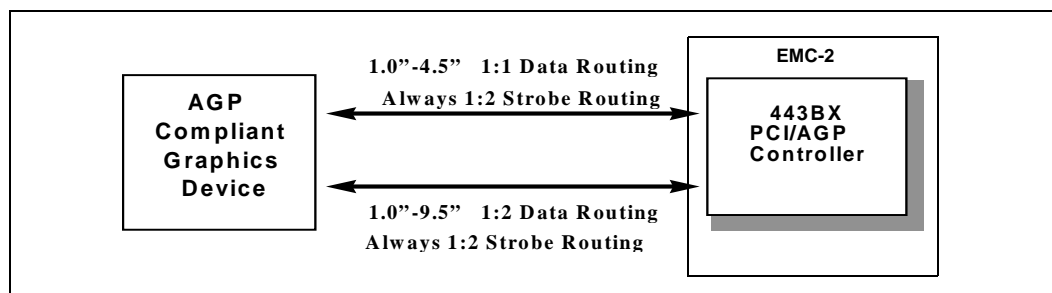
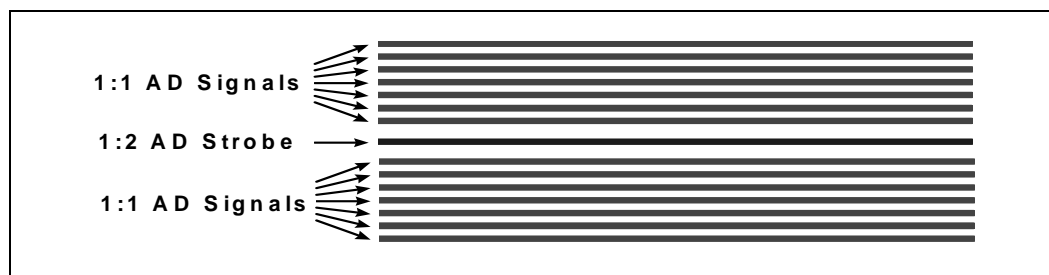

Figure 15. Signal Layout Recommendations



5.1.1.1 Data and Strobe Signal Routing Recommendations

Table 10. Motherboard Recommendations

Width:Space	Trace	Line Length	Line Length Matching
1:1(Data)/1:2(Strobe)	Data /Strobe	1.0 in < line length < 4.5 in	0.5 in, strobe longest trace
1:2	Data/Strobe	1.0 in < line length < 9.5 in	0.5 in, strobe longest trace

The line length mismatch must be less than 0.5” and the strobe must be the longest signal of the group. For example, if the strobe is at 4.0 inches, the data line can be from 3.5 to 4.0 inches in length. It is best to reduce the line length mismatch wherever possible to insure added margin. The strobe is always required to have 1:2 trace spacing. It is also best to separate the traces by as much as possible in order to reduce the amount of trace-to-trace coupling.

Note: Under certain layouts, crosstalk and ground bounce can be observed on the AD_STB signals of the AGP interface. Although Intel has not observed system failures due to this issue, noise margin has been improved by enhancing the AGP buffers on the 82443BX. For new designs, additional margin can be obtained by following AGP layout guidelines.

5.1.1.2 Control Signal Routing Recommendations

Some of the control signals require pull-up resistors to be installed on the motherboard. Pull-up resistors should be discrete resistors, since resistor packs will need longer stub lengths and may violate timing requirements. The stub length to these pull-up resistors must be controlled. The maximum stub length on a strobe trace is < 0.1 inch. The maximum stub trace length on all other traces is < 0.5 inch. For Pull-up recommendations, see “AGP Signals” on page 38..

Table 11. Control Signal Line Length Recommendations

Width:Space	Board	Trace	Line Length	Pull-up Stub Length
1:1	Motherboard	Control Signals	1.0 in < line length < 8.5 in	< 0.5 in (Strobes < 0.1in)
1:2	Motherboard	Control Signals	1.0 in < line length < 10.0 in	< 0.5 in (Strobes < 0.1in)

5.2 ACPI Compliance Requirements

Based on the Advanced Configuration and Power Interface (ACPI) specification, the AGP graphics device must be ACPI compliant and must implement its own self power management circuitry, such as self clock-gating and an idle bus detection mechanism to reduce power. However, in an embedded Pentium® II processor-based platform the AGP device clock is a derivative of the host clock.

When the host clock stops (C3 state - Deep Sleep), the AGP clock also stops. An AGP_BUSY# protocol solves this instantaneous AGP stop clock problem. The AGP graphics device must signal the operating system or the south bridge that it is currently busy and the AGP clock should not be stopped.

The AGP device internally protects its core logic to ensure that an illegal clock will not corrupt the AGP device state. This protection gates the internal clock nets used for the device's logic from the time STP_AGP# is asserted until it is deasserted. The STP_AGP# signal is an indication that the AGP clock will not be valid for much longer and should be gated off for protection. STP_AGP# should be connected to the PIIX4E's SUS_STAT1# signal.

The AGP_BUSY# signal indicates that the graphics controller requires the GCLK to be running. This signal should be connected to one of the PIIX4E's PCIREQ# pins. When the PCIREQ# pin must be shared, it can be logically ORed with one of the PIIX4E's PCIREQ# inputs. AGP_BUSY# is an open-drain signal from the graphics device and requires a 10 K Ω Pull-up resistor.

AGP_SUSPEND# is for AGP devices that support Suspend mode. The AGP_SUSPEND# signal can be connected to the PIIX4E's SUSB# signal.

5.3 AGP IDSEL Routing

An AGP compliant master is composed of a PCI compliant target interface and an AGP compliant master interface. (Optionally the device can also include a PCI compliant master interface when required.) When used in a PCI mode of operation, the AGP device must provide an external IDSEL that is connected to AD16. When the AGP device is designed for exclusive operation on the AGP interface the device does not have an external IDSEL pin, therefore IDSEL does not need to be routed.

6.0 Design Guideline Checklists

Design checklists provided in this section are intended to be used for schematic reviews of the 266 MHz EMC-2 based platform designs. The checklists do not represent the only way to design a system, but do provide recommendations. The system designer should examine the checklist items for correctness. Additional design considerations are also provided.

6.1 Resistor Values

Pull-up and pull-down register values are system dependent. The appropriate value for your system can be determined from an AC/DC analysis of the pull-up voltage used, the current drive capability of the output driver, input leakage currents of all devices on the signal net, the pull-up voltage tolerance, the pull-up/pull-down resistor tolerance, the input high/low voltage specifications, the input timing specifications (RC rise time), etc. Analysis should be done to determine the minimum

and maximum values that may be used on an individual signal. Engineering judgment should be used to determine the optimal value. This determination can include cost concerns, commonality considerations, manufacturing issues, specifications and other considerations.

A simplistic DC calculation for a pull-up value is:

$$R_{MAX} = (V_{CC_{PU}} MIN - V_{IH} MIN) / I_{Leakage} MAX$$

$$R_{MIN} = (V_{CC_{PU}} MAX - V_{IL} MAX) / I_{OL} MAX$$

Figure 16. Pull-up Resistor Example

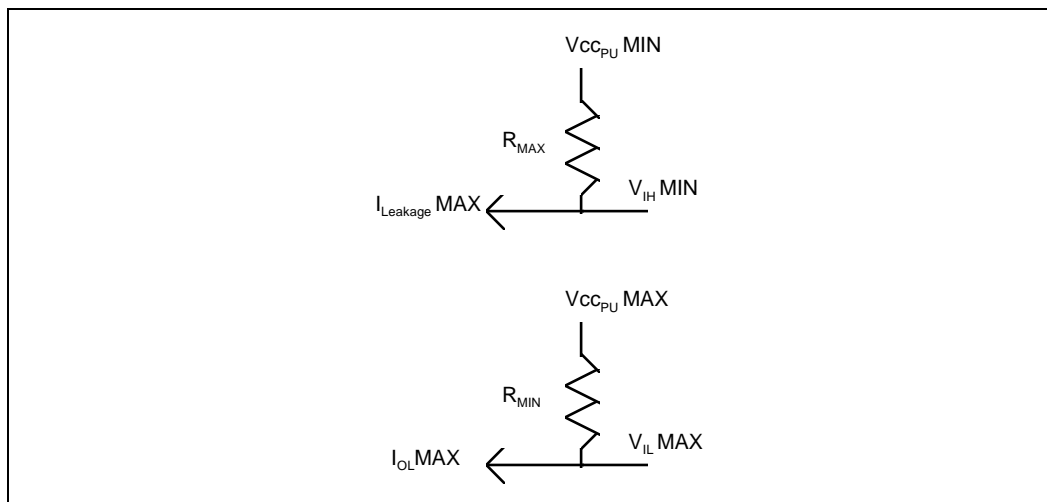

6.2 EMC-2 Design Checklist []Pass, []Fail

For PIIX4E recommendations on the I/O system electronics board, please see “82371EB (PIIX4E) Design Checklist []Pass, []Fail” on page 40.

6.2.1 EMC-2 Errata

Please see the *Mobile Pentium® II Processor Specification Update* (order number 243887) for workarounds for any errata that may be present on the stepping used.

6.2.2 Power and Ground Pins

- V_DC is the DC voltage driven from the power supply and is required to be between 5-V and 21-V DC \pm 5%. The module cannot be inserted or removed while V_DC is powered on.
- V_3S is a SUSB#-controlled 3.3-V voltage supply which is an output of the voltage regulator on the system electronics. This rail should be off during Suspend-to-RAM (STR), Suspend-to-Disk (STD), and Soft-Off (SOFF) modes.
- V_5 is a SUSC# controlled 5-V voltage supply which is an output of the voltage regulator on the system electronics. This rail should be off during Suspend-to-Disk (STD), and Soft-Off (SOFF) modes.
- V_3 is a SUSC# controlled 3-V voltage supply which is an output of the voltage regulator on the system electronics. This rail should be off during Suspend-to-Disk (STD), and Soft-Off (SOFF) modes.

- V_CPUPU is driven by the EMC-2 to power processor interface signals such as the PIIX4E open-drain pull-ups for the processor/PIIX4E sideband signals.
- V_CLK is driven by the EMC-2 to power the HCLK drivers from the CK100-M clock source.
- VCCAGP is the VDDQ AGP voltage, and should be connected to V_3.
- V_{TT} is an output of the DC-DC regulator on the EMC-2, and is driven to the core voltage (VCC_CORE) of the processor. V_{TT} is used for ITP implementations.
- All unused active low 3.3-V tolerant inputs should be connected to V_3S with a 10-KΩ resistor unless otherwise stated.
- All unused active high inputs should be connected to ground (V_{SS}) through a 10-KΩ resistor unless otherwise stated.

6.2.3 Decoupling Requirements

In order to provide adequate filtering and in-rush current protection for any system design, bulk capacitance is required. A small amount of bulk capacitance is supplied on the EMC-2. To achieve proper filtering, additional capacitance should be placed on the system electronics. Table 12 details the bulk capacitance requirements for the system electronics when using the EMC-2.

Table 12. Module Capacitive Decoupling Requirements

Voltage Plane	Capacitance	ESR	Ripple Current	Rating (V)
V_DC	100 μF, 0.1 μF, 0.01 μF ¹	20 mΩ	1- 3.5 A ³	20% tolerance @ 35-V
V_5	100 μF, 0.1 μF, 0.01 μF ¹	100 mΩ	1 A	20% tolerance @ 10-V
V_3	470 μF, 0.1 μF, 0.01 μF ¹	100 mΩ	1 A	20% tolerance @ 6-V
V_3S	100 μF, 0.1 μF, 0.01 μF ¹	100 mΩ	1 A	20% tolerance @ 6-V
VCC_AGP	22 μF, 0.1 μF, 0.01 μF ¹	100 mΩ	1 A	20% tolerance @ 6-V
V_CPUPU	2.2 μF, 8200 pF ²	n/a	n/a	20% tolerance @ 6-V
V_CLK	10 μF, 8200 pF ²	n/a	n/a	20% tolerance @ 6-V

NOTES:

1. This capacitance should be located near the processor module connector.
2. V_CPUPU and V_CLK filtering should be located next to the system clock synthesizer.
3. Ripple current specification depends on V_DC input. For 5-V V_DC, a 3.5 A device is required. For V_DC at 18-V or higher, 1 A is sufficient.

6.2.4 Clock and Test Signals

- See “Clocking Guidelines” on page 25 for clocking guidelines.
- Use discrete resistors for the HCLK signals from the CK100-M. Do not mix HCLK, and PCLK signals coming from the CK100-M in resistor packs.
- FQS should be connected to the SEL pin of the CK100-M to provide the host clock frequency. CKBF-M should be on the V_3 rail and the CK100-M should be on the V_3S rail.
- The clock signal from the CKBF-M to the SODIMM should have 18 Ω series termination resistors.
- CONFIG[1] should be pulled to V_3ALWAYS with a 100-KΩ resistor on the system I/O.
- CONFIG[2] should be pulled to GND in all 440BX AGPset based designs. A weak 100-KΩ resistor may be used.

Table 13. Clock and Test Signal Resistor Values

Name	Termination Resistor (Ω)	Pull-up (Pull-down) Resistor (Ω)
HCLK	22 (see above)	None
PCLK	33 (see above)	None
DCLKO	18	None
DCLKRD	†	None
DCLKWR	†	None
GCLKO	18 [†]	None
GCLKIN	18 [†]	None
SDRAM_CLK	18 [†]	None
FQS	None	None

† See “Clock period, jitter, offset and skew are measured on the rising edge of the clock signals at 1.25-V for the 2.5-V clocks and at 1.5-V for the 3.3-V clocks.” on page 28.

6.2.5 SDRAM and EDO Signals

- See “Memory Guidelines” on page 14 for memory guidelines.
- MD[63:0] should have 18 Ω series termination resistors.

Table 14. SDRAM and EDO Signal Resistor Values

Name	Termination Resistor (Ω)	Pull-up (Pull-down) Resistor (Ω)
MD[63:0]	18	None

6.2.6 Module Strapping Options

- MAB9# is the AGP Disable strapping option on the EMC-2. This pin should be pulled up to V₃ with a 10-K Ω resistor when the AGP is disabled.

Table 15. EMC-2 Strapping Options

Pin Name	Function	Low	High	Internal Resistor	Status Register
MAB9#	AGP Disable	AGP Enabled	AGP Disabled	Pull-down	PMCR[1]

6.2.7 PCI Bus Signals

- See “PCI Bus Signals” on page 41.
- The EMC-2 supports only 3.3-V PCI.
- An 8.2 K Ω – 10 K Ω pull-up to V_{3S} should be placed on the CLKRUN# signal.
- The 82443BX does not implement the PERR# pin. Data parity errors are still detected and reported on SERR# (when enabled by SERRE and PERRE).

6.2.7.1 Design Considerations

The 82443BX supports up to five PCI masters with its REQ[4:0]#/GNT[4:0]# pairs. The PCI bus supports up to 10 PCI loads. The 82443BX and the PIIX4E each represent one load; other PCI components soldered on the motherboard add one load each; and each PCI connector adds approximately two loads. A design with four PCI slots and no motherboard devices uses all available PCI loads. When all five REQ[4:0]#/GNT[4:0]# pairs are used, simulation is required to ensure that the PCI Bus Specification Rev. 2.1 timings are met. It is recommended, per the PCI specification, that the design have series resistors (~100 Ω) on each of the PCI connector IDSEL lines.

Table 16. PCI Bus Signals Resistor Values

Name	Termination Resistor (Ω)	Pull-up (Pull-down) Resistor (Ω)
AD[31:0]	None	None
C/BE[3:0]#	None	None
FRAME#	None	10 K pull-up to V _{3S}
DEVSEL#	None	10 K pull-up to V _{3S}
IRDY#	None	10 K pull-up to V _{3S}
TRDY#	None	10 K pull-up to V _{3S}
STOP#	None	10 K pull-up to V _{3S}
REQ[4:0]#	None	10 K pull-up to V _{3S} if unused
GNT[4:0]#	None	10 K pull-up to V _{3S} if used
PHOLD#	None	10 K pull-up to V _{3S}
PHLDA#	None	10 K pull-up to V _{3S}
PAR	None	None
SERR#	None	10 K pull-up to V _{3S}
CLKRUN#	None	8.2 ~ 10 K pull-up to V _{3S}
PCIRST#	33 (see "PCI Bus Signals" on page 41)	None
PLOCK#	None	10 K pull-up to V _{3S}

6.2.8 Processor/PIIX4E ISA Bridge Sideband Signals

- Pull-ups to V_{CPUPU}: INIT# - 1 KΩ, STPCLK# - 680 Ω; LINT1#/NMI, LINT0#/INTR, IGNNE#, A20M#, SMI# - 4.7 KΩ. These are open collector outputs from the PIIX4E component.
- CPURST can be left unconnected for EMC-2 designs.
- Refer to the *System Management Bus Specification* (see Table 2) for descriptions and specifications of the three SMBus signals: SMBALERT#, SMBCLK, and SMBDATA. A pull-up resistor is required. Values will vary depending on V_{DD} and the actual capacitance of the bus.

Table 17. Sideband Signal Resistor Values

Name	Termination Resistor (Ω)	Pull-up (Pull-down) Resistor (Ω)
FERR#	None	None
CPURST	None	None
IGNNE#	None	4.7 K pull-up to V_CPUPU
INIT#	None	1 K pull-up to V_CPUPU
INTR	None	4.7 K pull-up to V_CPUPU
NMI	None	4.7 K pull-up to V_CPUPU
A20M#	None	4.7 K pull-up to V_CPUPU
SMI#	None	4.7 K pull-up to V_CPUPU
STPCLK#	None	680 pull-up to V_CPUPU

6.2.9 Power Management Signals

- MID[3:0] should have a 100 K Ω pull-up to V_3S.
- BXPWROK must transition from inactive (low) to active (high) a minimum of 1 ms after BX_VCC is within the specified Functional Operating Range. See “82443BX Host Bridge Controller Power Sequencing” on page 69 for more information.

Table 18. Power Management Signals Resistor Values

Name	Termination Resistor (Ω)	Pull-up (Pull-down) Resistor (Ω)
SUS_STAT#	None	None
VR_ON	None	None
VR_PWRGD	None	None
SM_CLK	None	Refer to the <i>System Management Bus Specification</i>
SM_DATA	None	Refer to the <i>System Management Bus Specification</i>
ATF_INT#	None	Refer to the <i>System Management Bus Specification</i>
MID[3:0]	None	100 K pull-up to V_3S

6.2.10 AGP Signals

- See “82443BX AGP Interface for EMC-2 Design” on page 31
- The MAB9# strapping option for the 443BX is on the I/O system electronic board. This allows the designers to enable or disable the AGP.
- When the AGP is disabled all AGP signals are three-stated and isolated. They do not need external pull-up resistors.
- Unconnected pins on a disabled AGP interface: PIPE#, SBA[7:0], RBF#, ST[2:0], AD_STBA, AD_STBB, SB_STB, G_FRAME#, G_IRDY#, G_TRDY#, G_STOP#, G_DEVSEL#, G_REQ#, G_GNT#, G_AD[31:0], G_C/BE[3:0]#, G_PAR.
- The AGP graphic card must be able to signal the operating system, or the south bridge, that it is currently busy and the AGP clock should not be stopped. See “ACPI Compliance Requirements” on page 33.

- The LOCK# signal is not supported on the AGP interface, even for PCI operations.
- AGP signals that require pull-ups should use discrete resistors not resistor packs.
- When the AGP is enabled the following AGP signals must have pull-up resistors of approximately 8.2 KΩ to VCCAGP to ensure they contain stable values when no agent is actively driving the bus: G_FRAME#, G_TRDY#, G_IRDY#, G_DEVSEL#, G_STOP#, SERR#, PERR#, RBF#, INTA#, INTB#, PIPE#, G_REQ#, G_GNT#, SB_STB, AD_STBA, AD_STBB.
- GPAR requires a 100 KΩ pull-down resistor when the design is interfacing to an AGP connector, or when the AGP compliant device uses PIPE# or side band addressing. When the AGP compliant device uses GFRAME# only, the pull-down resistor is not needed.
- When side band addressing is disabled, SBA[7:0] are isolated and no external pull-ups are required.
- When PIPE# is used to queue addresses the master is not allowed to queue addresses using the side band addressing bus.
- No external termination (for signal quality) is required by the specification. Termination can be added to improve signal integrity, provided that performance (timing) constraints are still satisfied.
- AGP interrupts may be shared with PCI interrupts similar to the recommendations in the PCI Revision 2.1 specification. For example, in a system with three PCI slots and one AGP, interrupts should be connected such that each of the four INTA# lines connects to a unique input on the PIIX4E. It is recommended that the interrupts be staggered. It is also recommended that each PIRQ be programmed to a different IRQ, if possible.
- The system electronics (S.E.) board designer must properly interface the AGP interrupts to the PCI bus.
- In order to minimize the impact of any impedance mismatch between the S.E. board and the add-in card, an impedance of 55 Ω ± 15% is strongly recommended.
- The AGP strobe signals must be grouped with their associated data signals. AD_STBA with G_AD[15:0], AD_STBB with G_AD[31:16], SB_STB with SBA[7:0]. See Section 5.1, “Layout and Routing Guidelines” on page 31.
- Some onboard AGP devices may require their own VREF. This should be generated locally from the AGP interface VCCAGP rail. You should use a separate voltage divider from the AGP_REF for 82443BX. Do not connect the two. The VCCAGP rail is the AGP controller I/O ring voltage supply.

Table 19. AGP Signals Resistor Values (Sheet 1 of 2)

Name	Termination Resistor (Ω)	Pull-up (Pull-down) Resistor (Ω)
GAD[31:0]	None	None
GC/BE[3:0]#	None	None
GFRAME#	None	8.2 K pull-up to VCCAGP
GDEVSEL#	None	8.2 K pull-up to VCCAGP
GIRDY#	None	8.2 K pull-up to VCCAGP
GTRDY#	None	8.2 K pull-up to VCCAGP
GSTOP#	None	8.2 K pull-up to VCCAGP
GREQ#	None	8.2 K pull-up to VCCAGP

Table 19. AGP Signals Resistor Values (Sheet 2 of 2)

Name	Termination Resistor (Ω)	Pull-up (Pull-down) Resistor (Ω)
GGNT#	None	8.2 K pull-up to VCCAGP
GPAR	None	100 K pull-down (If AGP device does NOT use GFRAME# ONLY)
PIPE#	None	8.2 K pull-up to VCCAGP
SBA[7:0]	None	None
RBF#	None	8.2 K pull-up to VCCAGP
ST[2:0]	None	None
ADSTB[B:A]	None	8.2 K pull-up to VCCAGP
SBSTB	None	8.2 K pull-up to VCCAGP

6.3 82371EB (PIIX4E) Design Checklist []Pass, []Fail

6.3.1 82371EB (PIIX4E) Errata

- Please see the *82371EB (PIIX4E) PCI ISA IDE Xcelerator Specification Update* for workarounds or any errata that may be applicable to the stepping used.

6.3.2 Power and Ground Pins

- V_3ALWAYS is a 3.3-V rail that is connected to V_{CC}(SUS) of the PIIX4E. V_3ALWAYS should power off only when the system is mechanically off.
- V_{CC} and V_{CC}(USB) must be tied to V_3S. V_{CC}(USB) should be tied to the same voltage rail as the PIIX4E core.
- V_{CC}(RTC) should be tied to the 3.3-V supply voltage for the RTC logic.
- V_{REF} must be tied to 5-V in a 5-V tolerant system. This signal must power up before or simultaneous to V_3S, and it must power down after or simultaneous to V_3S. Note that most IDE devices operate at 5-V, so even when running a 3.3-V PCI bus, the PIIX4E IDE interface must be 5-V tolerant.
- V_{REF} can be tied to V_3S in a non-5-V tolerant system. IDE devices are generally 5-V devices.
- Tie V_{SS} and V_{SS}(USB) to ground.
- All unused active low 3.3-V tolerant inputs should be connected to V_3S with a 10-K Ω resistor unless otherwise stated.
- All unused active high inputs should be connected to ground (V_{SS}) through a 10-K Ω resistor unless otherwise stated.

Table 20. PIIIX4E Power Signal Pin Assignments

Power Pins	Ball Number
VCC	E9, E11, E12, E16, F5, F6, F14, F15, G6, P15, R6, R7, R15, T6
VCC(RTC)	L16
VCC(SUS)	N16,R16
VCC(USB)	K5
VSS(USB)	J5
VSS	D10, E7, E13, J9-J12, K9-K12, L9-L12, M9-M12

6.3.3 Clock and Test Signals

- USB Clock - A 48 MHz clock with a duty cycle of better than 40/60% should be fed into the PIIIX4E's USB clock input, pin L3.
- Place a 10-K Ω pull-up resistor on TEST# to V_3ALWAYS. Test signals reside in the Suspend/Resume well.
- In a Pentium II processor-based system, CONFIG[1] should be pulled to V_3ALWAYS with a 100-K Ω resistor.
- CONFIG[2] should be pulled to GND with a 100-K Ω resistor in all 440BX AGPset-based designs.

Table 21. Clock and Test Signal Resistor Values

Name	Termination Resistor (Ω)	Pull-up (Pull-down) Resistor (Ω)
TEST#	None	10 K Pull-up to V_3ALWAYS
CONFIG[1]	None	100 K Pull-up to V_3ALWAYS
CONFIG[2]	None	100 K Pull-down

6.3.4 PCI Bus Signals

- All unused general purpose inputs (GPIs) should be pulled to a valid logic level with a 10-K Ω resistor. When pulled high, they should be pulled to V_3S except for the GPIs that are in the V_{CC}(SUS) well.
- All unused outputs can be left as no-connects.
- All IDSEL signals should have a 100-W series resistor at each device.
- In a 5-V PCI environment, place 2.7 K Ω pull-up resistors to 5-V on PIRQ[A:D]#, SDONE, SBO#, FRAME#, TRDY#, STOP#, IRDY#, DEVSEL#, PLOCK#, PERR#, SERR#, REQ64# and ACK64# on the PCI bus.
- Place the 10-K Ω pull-up resistors to V_3S on PCIREQ[D:A]# and REQ[A:C]# when these signals are unused or when using a PCI add-in slot to insure that these signals do not float.
- In a 3.3-V PCI environment, place 10-K Ω pull-up resistors to V_3S on PIRQ[A:D]#, SDONE, SBO#, FRAME#, TRDY#, STOP#, IRDY#, DEVSEL#, PLOCK#, PERR#, SERR#, REQ64# and ACK64# on the PCI bus.

- For all new designs, make sure that the PIIX4E does not connect IDSEL to AD12, becoming device 1. On 82443BX, AGP is known as device 1 whether disabled or not. Connect IDSEL from PIIX4E to AD18.
- For systems in which the PCIRST# signal is lightly loaded (<50 pF), place a 33-W series termination resistor on this signal. This resistor should be placed as close as possible to the PIIX4E.

Table 22. PCI Bus Signal Resistor Values

Name	Termination Resistor (Ω)	Pull-up (pull-down) Resistor (Ω)
Unused GPIs	None	10 K to a valid level
IDSEL signals	100	None
PIRQ[A:D]#	None	10 K Pull-up to V _{3S}
SDONE	None	10 K Pull-up to V _{3S}
SBO#	None	10 K Pull-up to V _{3S}
FRAME#	None	10 K Pull-up to V _{3S}
TRDY#	None	10 K Pull-up to V _{3S}
STOP#	None	10 K Pull-up to V _{3S}
IRDY#	None	10 K Pull-up to V _{3S}
DEVSEL#	None	10 K Pull-up to V _{3S}
PLOCK#	None	10 K Pull-up to V _{3S}
PERR#	None	10 K Pull-up to V _{3S}
SERR#	None	10 K Pull-up to V _{3S}
REQ64#	None	10 K Pull-up to V _{3S}
ACK64#	None	10 K Pull-up to V _{3S}
PCIREQ[D:A]#	None	10 K Pull-up to V _{3S}
REQ[A:C]#	None	10 K Pull-up to V _{3S}

6.3.5 ISA/EIO Signals

- When implementing Power On Suspend (POS) mode, ISA signals should be pulled up to V_{3S}. Otherwise use V_{5S}.
- Use 4.7 K Ω pull-up resistors on SD[15:0], MEMR#, MEMW#, IOR#, IOW#, IOCS16#.
- Use 1 K Ω pull-up resistors on IOCHRDY, MEMCS16#, REFRESH#, ZEROWS#.
- Use 10 K Ω pull-up resistors on IRQx. IRQ8# resides in the V_{CC}(SUS) well, it must be pulled to V_{3ALWAYS}. When IRQ8# is not used, its default is GPI[6] and it requires a 10 K Ω external pull-up resistor.
- Use a 4.7 K Ω pull-down resistor on DRQx.
- When using the EIO bus, IOCHK# becomes a general-purpose input and in ISA, IOCHK# requires a 4.7 K Ω pull-up resistor.

Table 23. ISA/EIO Signal Resistor Values

Name	Termination Resistor (Ω)	Pull-up (Pull-down) Resistor (Ω)
SD[15:0]	None	4.7 K Pull-up to V_3S
MEMR#	None	4.7 K Pull-up to V_3S
MEMW#	None	4.7 K Pull-up to V_3S
IOR#	None	4.7 K Pull-up to V_3S
IOW#	None	4.7 K Pull-up to V_3S
IOCS16#	None	4.7 K Pull-up to V_3S
IOCHRDY	None	1 K Pull-up to V_3S
MEMCS16#	None	1 K Pull-up to V_3S
REFRESH#	None	1 K Pull-up to V_3S
ZEROWS#	None	1 K Pull-up to V_3S
IRQx	None	10 K Pull-up to V_3S (see above)
DRQx	None	4.7 K (Pull-down)
SIRQ	None	10 K Pull-up to V_3S
IOCHK#	None	4.7 K Pull-up (if using ISA bus)

6.3.6 Power Management Signals

- Power management signals that reside in the V_{CC}(SUS) well may require pull-ups, the pull-ups must be connected to V_3ALWAYS. These signals do not support 5-V input levels.
- EXTSMI# is an input at reset and an open drain output when activating an SMI# within the Serial IRQ function. Designers may need an 8.2 K Ω pull-up to V_3ALWAYS when it is not always being driven to a valid state.
- When CLKRUN# is not connected between the PIIX4E and the 82443BX, it should be tied low through a 100 Ω resistor at the 82443BX. When CLKRUN# is connected between the PIIX4E and the 82443BX, an 8.2 K Ω – 10 K Ω pull-up to V_3S should be placed on the CLKRUN# signal.
- SUS_STAT1# is connected between the 82443BX and the PIIX4E.
- SUS_STAT2# is connected from the PIIX4E to the devices that must be informed of the stopping of the clocks.
- PCI_STP# is connected to the clock synthesizer to stop the PCI clocks.
- CPU_STP# is connected to the clock synthesizer to stop the processor clock.
- SUSA# is connected to the clock synthesizer's PWR_DWN# pin through a Schottky diode with a 10 K Ω pull-up resistor. Alternatively, SUSA# may be used to control the clock synthesizer's power plane.

Figure 17. Clock Design Block Diagram

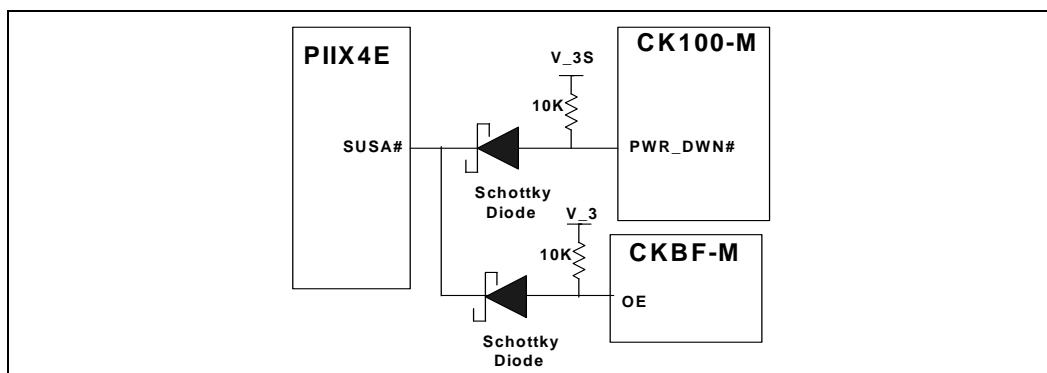

- SUSB# and SUSC# are used to control the power planes.
- THRM# is connected to the thermal protection logic.
- PCIREQ[D:A]# is connected between the PIIX4E and the PCI bus. Bus master requests are considered to be power management events.
- Connect RI# to the modem when this feature is used.
- Connect BATLOW# to the battery monitoring logic when this feature is implemented.
- Connect LID to the lid monitoring logic of the system.
- PWRBTN# is connected to logic that allows the user to switch from and to suspend.
- RSMRST# is connected to a switch to allow a complete system reset. This signal resides in the V_{CC}(RTC) well. Its potential must not exceed that of V_{CC}(RTC).

Table 24. Power Management Signal Resistor Values

Name	Damping Resistor (Ω)	Pull-up (Pull-down) Resistor (Ω)
EXTSMI#	None	See above
CLKRUN#	None	8.2 KΩ~10 KΩ Pull-up to V _{3S} (if connected from PIIX4E to 82443BX) 100 KΩ (Pull-down) otherwise

6.3.7 USB Interface

- Refer to the *PIIX4 USB Design Guide* (see Table 2) for the layout recommendations for USB, clock, over-current detection circuit and general board layout recommendations.

6.3.8 IDE Interface

- 5.6 KΩ pull-down resistors on PDDREQ and SDDREQ.
- 1 KΩ pull-up resistors on PIORDY and SIORDY.
- 470 Ω pull-down resistor on pin 28 of the IDE connector (CSEL). Support Cable Select (CSEL) is a PC97 requirement. The state of the cable select pin determines the master/slave configuration of the hard drive at the end of the cable.
- The primary IDE connector uses IRQ14, and the secondary IDE connector uses IRQ15.

- The ATA-4 specification requires 33 Ω series terminating resistors on P/SDIOR, P/SDIOW#, P/SDCS[1,3]#, P/SDA[2:0], P/SDDACK# and P/SDD[15:0]. These series termination resistors should be placed as close as possible to the PIIX4E.
- For Ultra-DMA enabled systems, the ATA-4 specification also requires 82 Ω series terminating resistors on P/SDDREQ, INTRQx and P/SIORDY. These series terminating resistors should be placed as close as possible to the PIIX4E.
- When the distance between the PIIX4E and connector is greater than 4", the terminating resistor should be placed within 1" of the PIIX4E.
- When using the ISA reset signal RSTDRV from the PIIX4E, it should be routed through a Schmitt trigger for RESET# signals.
- Ground pins 19, 2, 22, 24, 26, 30, 40 of both ATA connectors
- Pins 20 and 34 of both ATA connectors should be left unconnected.
- According to ATA-4 specification, a 10 K Ω pull-down resistor is required on DD7 to allow a host to recognize the absence of a device at power-up.
- Exceptions: When the PIIX4E's IDE interface is configured as Primary 0/Primary 1, and two IDE devices are connected, it should appear to the devices as if they are on the same cable. See *Intel® 82371AB PCI-to-ISA/IDE Xcelerator (PIIX4)* datasheet (order number 290562).
 - Both IDE devices should connect to IRQ14.
 - CSEL connected (pin28) together between the two ATA connectors and be pulled down with a 470 Ω resistor to meet PC97 requirement.
 - DIAG (pin 34) connected together between the two ATA connectors.

Table 25. IDE Interface Signal Resistor Values

Name	Termination Resistor (Ω)	Pull-up (pull-down) Resistor (Ω)
PDDREQ	33 (82 for Ultra DMA)	5.6 K (pull-down)
SDDREQ	33 (82 for Ultra DMA)	5.6 K (pull-down)
PIORDY	82 (Ultra DMA only)	1 K Pull-up
SIORDY	82 (Ultra DMA only)	1 K Pull-up
CSEL (Pin 28)	None	470 (pull-down)
All signals to the two IDE connectors	33	None
DD7	33	10 K (pull-down)

6.3.9 BIOS to Flash Memory Interface

2 Mbits of flash is usually all that is required to support the 82443BX in all configurations. These are the recommendations for an Intel 28F200BV flash part.

- Use 0.01 μ F - 0.1 μ F capacitors for power supply (V_{CC} and V_{PP}) decoupling.
- Connect BYTE# to GND when a x16 flash device is used to configure it for x8.
- Use GPOx to control the WP# signal.
- Connect V_{PP} to 5-V.
- Use GPOx to control the RP# signal.

7.0 Power Sequencing

This section provides a summary of the power sequencing requirements and options of the 440BX AGPset. It provides a detailed description of the PIIX4E Suspend/Resume sequence, signaling protocols, and timings. The recommended usage model for power plane control in a 440BX platform using PIIX4E power management signals is described.

This section does not represent the only way to design a system, but it does provide recommendations for using the 440BX AGPset.

7.1 PIIX4E Power Sequencing

7.1.1 Power Sequencing Requirements

In systems requiring 5-V tolerance, the VREF signal must be tied to 5-V. This signal must power up before or simultaneous to V_{CC} . It must power down after or simultaneous to V_{CC} . In a non-5-V tolerant system (3.3-V only), this signal can be tied directly to V_{CC} . There are then no sequencing requirements. Refer to Figure 18 for an example circuit schematic, which may be used to ensure the proper VREF sequencing.

The PIIX4E V_{CC} and $V_{CC}(USB)$ supplies are separated internally in order to reduce noise on USB signals. They should not be powered up or down independently of one another. They should be connected to the same power plane on the motherboard. There are no other power sequencing requirements for the various V_{CC} power supplies to the PIIX4E.

Figure 18. VREF Supply Schematic

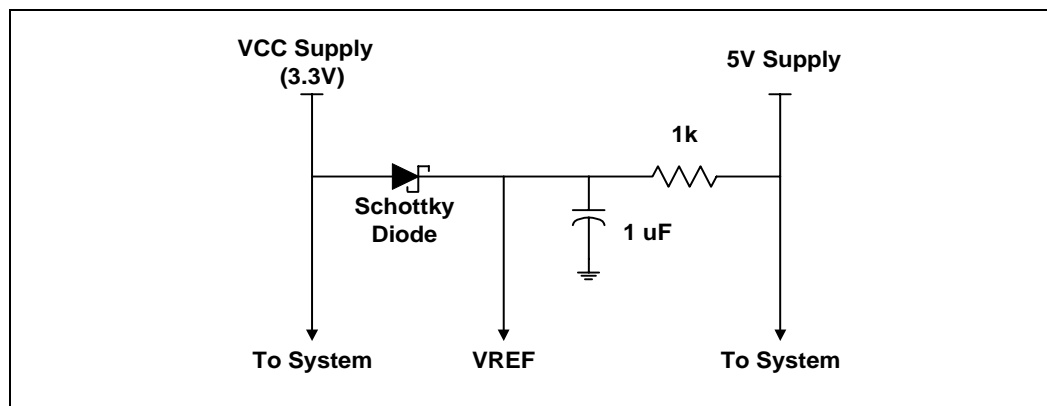

7.1.2 Suspend/Resume and Power Plane Control

The PIIX4E supports three different Suspend modes. The common system usage model for these modes is described here and includes Power On Suspend (POS), Suspend to RAM (STR), and Suspend to Disk (STD). This mode definition allows for other system usage models that use the PIIX4E suspend/resume control signals in other ways. The common system mode names are used throughout this document.

The PIIX4E power management architecture is designed to allow systems to support multiple suspend modes, and to switch between those modes as required. A suspended system can be resumed by a number of different events. The system returns to full operation, and can then continue processing or be placed into another suspend mode. The new mode can be at a lower power mode than from what it resumed.

7.1.2.1 Power On Suspend (POS) System Model

All devices are powered up except for the clock synthesizer. The Host and PCI clocks are inactive, and the PIIX4E provides control signals and the 32 KHz Suspend Clock (SUSCLK) to allow for DRAM refresh and to turn off the clock synthesizer. The only power consumed in the system while it is in POS mode is due to DRAM refresh and leakage current of the powered devices.

When the system resumes from POS mode, the PIIX4E can resume without resetting the system, can reset the processor only, or can reset the entire system. When no reset is performed, the PIIX4E only needs to wait for the clock synthesizer and processor PLLs to lock before the system is resumed. This takes typically 20 ms.

7.1.2.2 Suspend to RAM (STR)

Power is removed from most of the system components during STR, except the DRAM. Power is supplied to the host bridge (for DRAM Suspend Refresh) and the PIIX4E's RTC and Suspend Well logic. The PIIX4E provides control signals and a 32 KHz Suspend Clock (SUSCLK) to allow for DRAM refresh and to turn off the clock synthesizer and other power planes.

The PIIX4E resets the system on resume from STR.

7.1.2.3 Suspend to Disk (STD) and Soft Off (SOff)

Power is removed from most of the system components during STD. Power is maintained to the RTC and Suspend Well logic in the PIIX4E.

The PIIX4E resets the system on resume from STD.

The STD state is also called the Soft Off (SOff) state. The difference depends on whether the system state is restored by software to a pre-suspend condition or if the system is rebooted.

7.1.2.4 Mechanical Off (MOff)

This is not a suspend state. This is a condition where all power except the RTC battery has been removed from the system. It is typically controlled by a mechanical switch that turns off AC power to a power supply. It could be used as a condition in which an embedded system's main battery has been removed.

The PIIX4E controls the system entering the various suspend states through the suspend control signals listed in Table 26. Upon initiation of suspend, the PIIX4E asserts the SUS_STAT[1-2]#, SUSA#, SUSB#, and S USC# signals in a well defined sequence to switch the system into the desired power state. The SUSA#, SUSB#, and S USC# signals can be used to control various power planes in the system. The SUS_STAT1# signal is a status signal that indicates to the host bridge when to enter or exit a suspend state, or when to enter or exit a stop clock state (when the system is still running). This is typically used to place the DRAM controller into a Suspend Refresh mode of operation. The SUS_STAT2# signal is a status signal that can be used to indicate to other system devices when to enter or exit a suspend state (like the graphics and Cardbus controllers). See

“System Suspend and Resume Control Signaling” on page 50 for sequencing details. Note that these signals are associated with a particular type of suspend mode and power plane for descriptive purposes here. The system designer is free to use these signals to control any type of function desired.

The system is placed into a suspend mode by programming the Power Management Control register. The Suspend Type is first programmed and then the Suspend Enable bit is set. This causes the PIIX4E to automatically sequence into the programmed suspend mode.

Table 26. Power State Decode

Power State	RSMRST#	SUS_STAT1#	SUS_STAT2#	SUSA#	SUSB#	SUSC#
On	1	x [†]	1	1	1	1
POS	1	0	0	0	1	1
STR	1	0	0	0	0	1
STD/SOFF	1	0	0	0	0	0
Mechanical Off	0	0	0	0	0	0

[†] SUS_STAT1# is also used when the system is running. It indicates to the Host-to-PCI bridge when to switch between the normal and suspend refresh mode for DRAM Stop Clock support. In the Stop Clock condition, HCLK is stopped and the Host-to-PCI bridge must run DRAM refresh from the internal oscillator.

7.1.3 System Resume

The PIIX4E can be resumed from either a Suspend or Soft Off state. Depending on the suspend state that the system is in, different features can be enabled to resume the system. There are two classes of resume events, those whose logic resides in the PIIX4E main power well and those whose logic resides in the PIIX4E suspend well. Those in the suspend well can resume the system from any Suspend or Soft Off state. Those in the main power well can only resume the system from a Power On Suspend state. Table 27 lists the suspend states for which a particular resume event can be enabled.

Upon detection of an enabled resume event, the PIIX4E sets appropriate status signals and automatically transitions its suspend control signals to bring the system into a “full on” condition. The sequencing is shown in “System Suspend and Resume Control Signaling” on page 50.

Table 27. Resume Events Supported In Different Power States (Sheet 1 of 2)

Resume Event	Suspend States			
	POS	STR	STD/SOff	MOff
RTC Alarm (IRQ8) [†]	x	x	x	
SMBus Resume Event (Slave Port Match)	x	x	x	
Serial A Ring (RI)	x	x	x	
Power Button (PWRBTN#)	x	x	x	
EXTSMI (EXTSMI#)	x	x	x	
LID (LID)	x	x	x	
GPI 1	x	x	x	
GSTBY Timer Expiration	x	x	x	

Table 27. Resume Events Supported In Different Power States (Sheet 2 of 2)

Resume Event	Suspend States			
	POS	STR	STD/SOff	MOff
Interrupt (IRQ 1,3-15)	x			
USB	x			

† RTC Alarm only supports internal RTC. For external RTC implementations, the IRQ8 must be tied to one of the other resume input signals (GPI[1], LID, EXTSMI#,RI#) for the resume functionality.

7.1.3.1 System Resume Events

The various resume events and their programming model are shown here.

Table 28. Resume Event Programming Model

System Resume Event	Programming Model
PWRBTN# Asserted	[PWRBTN_EN]
LID Asserted - Polarity Select	[LID_EN] [LID_POL]
GPI[1] Asserted	[GPI_EN]
EXTSMI# Asserted	[EXTSMI_EN]
SMBus Events:	[ALERT_EN] [SLV_EN] [SHDW1_EN] [SHDW2_EN]
Global Standby Timer Expiration:	[GSTBY_EN]
Ring Indicate Assertion (RI#)	[RI_EN]
RTC Alarm (IRQ8)†	[RTC_EN]
USB Resume Signaling: (POS Only)	[USB_EN]
IRQ[1,3-7,9-15]: (POS Only)	[IRQ_RSM_EN]

† RTC Alarm only supports internal RTC. For external RTC implementations, the IRQ8 must be tied to one of the other resume input signals (GPI[1], LID, EXTSMI#,RI#) for the resume functionality.

7.1.3.2 Global Standby Timer Resume

The Global Standby Timer is used to monitor system activity during normal operation and can be reloaded by system activity events. Upon expiration, it generates an SMI#. When the system is placed in a Suspend Mode, the Global Standby Timer can be used to generate a resume event. The Global Standby Timer can enable two different timer resolutions for wake-up times from approximately 30 seconds to 8.5 hours. This can allow the system to transition into a lower power suspend state.

See the System Management Section of the *82371AB PCI-to-ISA/IDE Xcelerator (PIIX4)* datasheet for additional information about the Global Standby Timer.

7.1.4 System Suspend and Resume Control Signaling

The PIIX4E automatically controls the signals required to transition the system between the various power states. It provides control for Host and PCI clocks, main memory and video memory refresh, system power plane control, and system reset. Table 29 and Table 30 illustrate the common usage model for power plane control using the SUS[C:A]# signals. The PIIX4E Resume well should always be powered by a trickle supply (main battery or backup battery in an embedded system).

Table 29. Power Plane Control

SUSA# (POS)	SUSB# (STR)	SUSC# (STD)
Clock synthesizer Video display ¹	Processor (Low Power GTL+ supplies) PIIX4E Core Other system devices ²	82443BX Host Bridge Controller DRAM Graphics Controller

NOTES:

1. The video display (flat panel or CRT) may optionally be powered off in POS. This could be accomplished by using the PIIX4E's SUSA# or SUS_STAT2# signals to assert the video controller's STANDBY signal.
2. Devices may include mass storage, audio, or other devices that will not generate system resume events.

Table 30. Power Plane Control Using SUS[C:A]# Signals

Power Plane	Suspend Mode (Suspend Mode Signals Asserted by the PIIX4E)			
	Full On (None)	POS (SUSA#, SUS_STAT[2:1]#)	STR (SUS[B:A]# SUS_STAT[2:1]#)	STD (SUS[C:A]# SUS_STAT[2:1]#)
Clock Synthesizer	On	Off	Off	Off
Video Display	On	On/Off ¹	Off	Off
CPU	On	On	Off	Off
PIIX4E Core	On	On	Off	Off
Other Devices ²	On	On	Off	Off
82443BX	On	On	On	Off
DRAM	On	On	On	Off
Graphics Controller	On	On	On	Off
PIIX4E Resume	On	On	On	On
PIIX4E RTC	On	On	On	On

NOTES:

1. The video display (flat panel or CRT) may optionally be powered off in POS. This could be accomplished by using the PIIX4E's SUSA# or SUS_STAT2# signals to assert the video controller's STANDBY signal.
2. Devices may include mass storage, audio, or other devices that will not generate system resume events.

7.1.4.1 Power Well and Reset Signal Timings

Figure 19 shows the system timings for changing the power states of a system using the POS/STR/STD models.

7.1.4.2 PIIX4E Power Well Timings

Figure 19 describes the relative transitions for PIIX4E power supplies.

Figure 19. PIIX4E Power Well Timings

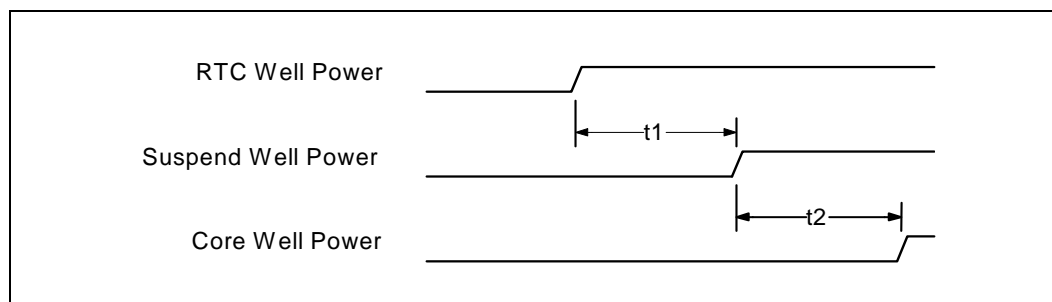

Table 31. PIIX4E Power Well Timings

Sym	Parameter	Min	Max	Unit	Notes
t1	RTC Well Power to Suspend Well Power	0		ns	
t2	Suspend Well Power to Core Well Power	0		ns	

7.1.4.3 RSMRST# and PWROK Timing

Figure 20 describes the required timings for PIIX4E power level active status signals.

Figure 20. RSMRST# and PWROK Timings

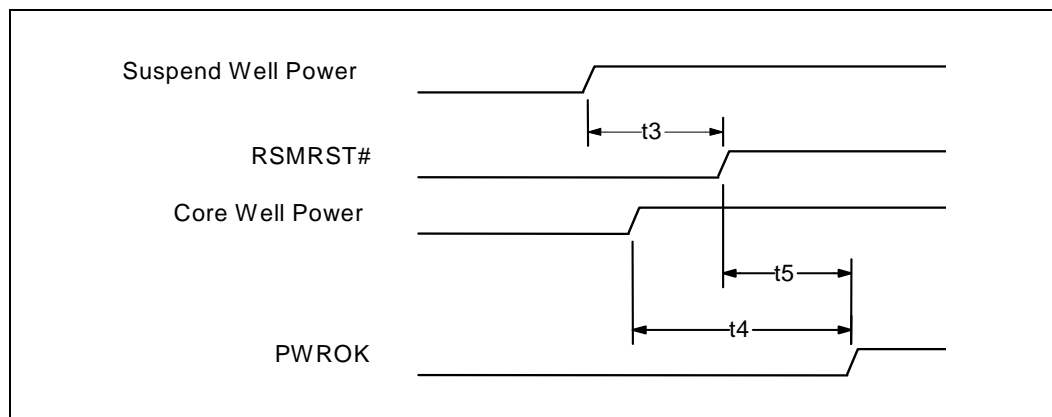

Table 32. RSMRST# and PWROK Timing

Sym	Parameter	Min	Max	Unit	Notes
t3	Suspend Well Power to RSMRST# Inactive	1		ms	
t4	Core Well Power to PWROK Active	1		ms	
t5	RSMRST# Inactive to PWROK Active	0		ns	

7.1.4.4 Suspend Well Power and RSMRST# Activated Signals

This describes the timing relationships for the PIIX4E power management signals that are powered from the Suspend Power well. These timings hold independent of the condition of Core Well power or the PWROK signal.

Figure 21. Suspend Well Power and RSMRST# Activated Signals

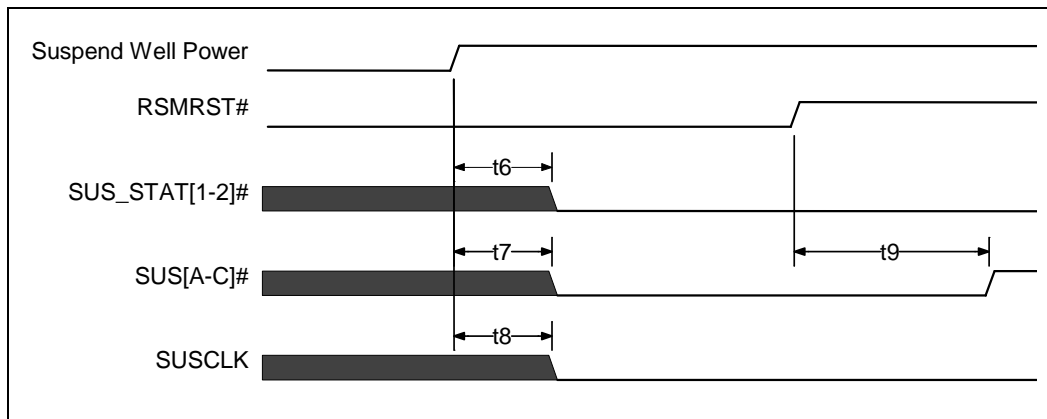

Table 33. Suspend Well Power and RSMRST# Timing

Sym	Parameter	Min	Max	Unit	Notes
t6	Resume Well Power and RSMRST# Active to SUS_STAT[1:2]# Active		1	RTC	1
t7	Resume Well Power and RSMRST# Active to SUS [A:C]# Active		1	RTC	1
t8	Resume Well Power and RSMRST# Active to SUSCLK Low		1	RTC	1
t9	RSMRST# Inactive to SUS[A:C]# Inactive	1	2	RTC	1

NOTE:

1. These signals are controlled off an internal RTC clock. One RTC unit is approximately 32 μs.

7.1.4.5 PCI Clock Control Timings

This section describes the timing requirements for the control of the system PCICLK. The system PCICLK timing shown in Figure 22 must be followed exactly for proper operation of the PC/PCI DMA or Serial IRQ logic. When the PC/PCI DMA and Serial IRQs are not used in the system, the system PCICLK stop timings must meet the system developer's requirements.

Figure 22. PCI Clock Stop Timing

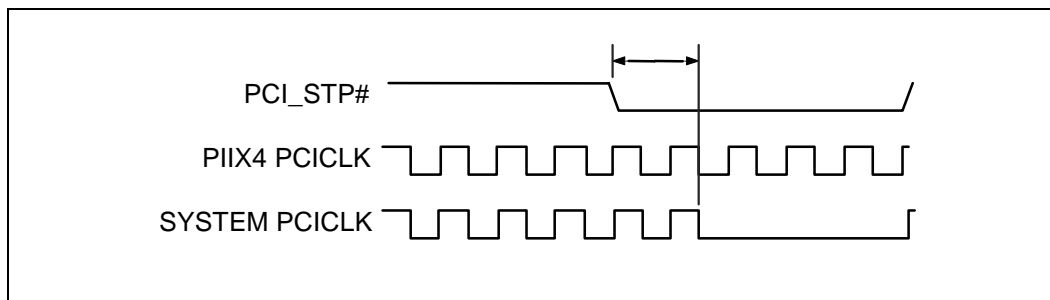
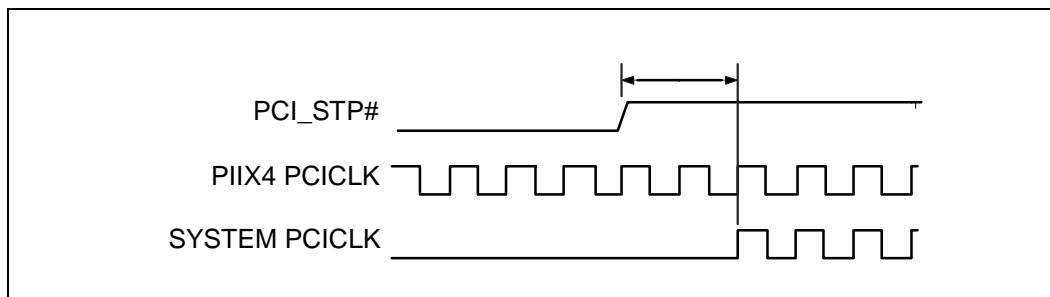

Figure 23 describes the timing requirements for the control of the system PCICLK. The system PCICLK timings shown Figure 23 must be followed exactly for proper operation of PC/PCI DMA or Serial IRQ logic. When PC/PCI DMA and Serial IRQs are not used in the system, the system PCICLK stop timings must meet system developers requirements.

Figure 23. PCI Clock Start Timing



7.1.4.6 Core Well Power and PWROK Activated Signals (RSMRST# Inactive Before Core Well Power Applied)

Figure 24 shows the timing relations for Power Management signals powered from the PIIX4E Main Core well. Here the Suspend well power active status signals (RSMRST#) transitions before the application of core well power to the PIIX4E. This figure corresponds to the usage model for PIIX4E power management.

Figure 24. Core Well Power and PWROK Activated Signals (RSMRST# Inactive before Core Well Power Applied)

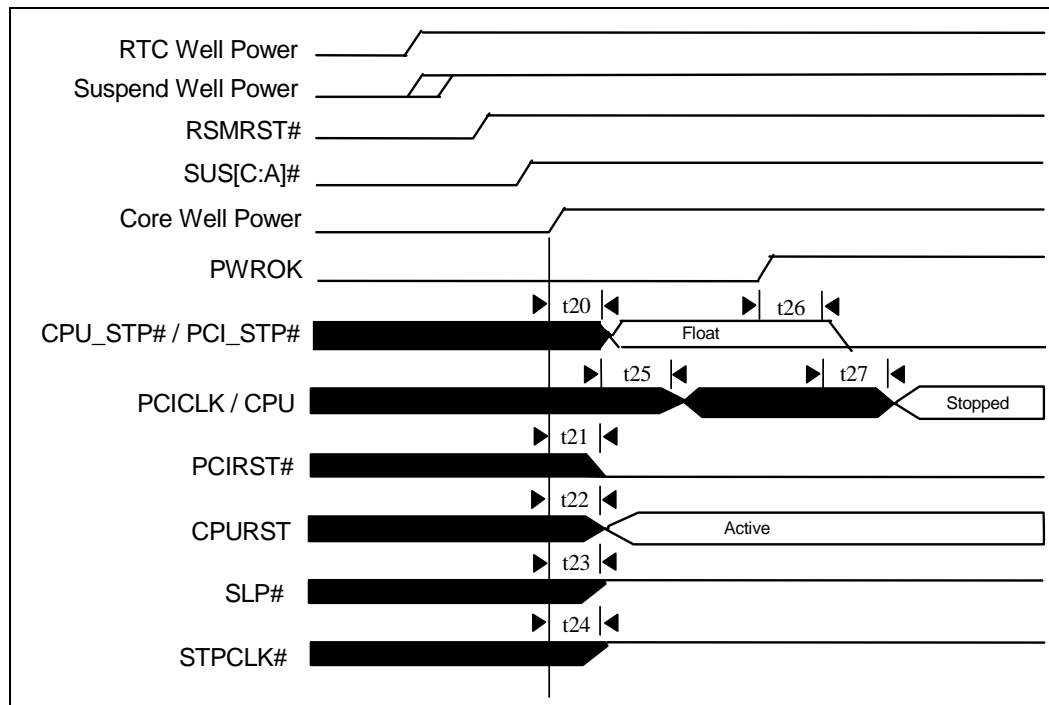

Table 34. Core Well Power and PWROK Timing

Sym	Parameter	Min	Max	Unit	Notes
t20	Core Well Power and PWROK Inactive to CPU_STP# and PCI_STP# Float		1	RTC	1
t21	Core Well Power and PWROK Inactive to PCIRST# Active		1	RTC	1
t22	Core Well Power and PWROK Inactive to CPURST Active		1	RTC	1
t23	Core Well Power and PWROK Inactive to SLP# Active		1	RTC	1
t24	Core Well Power and PWROK Inactive to STPCLK# Active		1	RTC	1

NOTES:

1. These signals are controlled off an internal RTC clock. One RTC unit is approximately 32 μs.
2. There are no specific requirements for these timings related to the PIIX4E. The system manufacturer should make sure that the clocks on power up meet any other system specifications. As a minimum, the clocks must be available and stable after time t29 shown in Figure 26.

Table 34. Core Well Power and PWROK Timing

t25	CPU_STP# and PCI_STP# Float to Clocks Running				2
t26	PWROK Active to CPU_STP# and PCI_STP# Active		1	RTC	1
t27	CPU_STP# and PCI_STP# Active to Clocks Stopped				2

NOTES:

1. These signals are controlled off an internal RTC clock. One RTC unit is approximately 32 μ s.
2. There are no specific requirements for these timings related to the PIIX4E. The system manufacturer should make sure that the clocks on power up meet any other system specifications. As a minimum, the clocks must be available and stable after time t29 shown in Figure 26.

7.1.4.7 Core Well Power and PWROK Activated Signals (Core Well Power Applied Before RSMRST# Inactive)

Figure 25 shows the timing relations for Power Management signals powered from the PIIX4E Core well. Here the power active status signals (RSMRST# and PWROK) transition after the application of all power to the PIIX4E. This is an example of an implementation in which the Core Well power plane is not controlled by the SUSB# signal. It can be applied to situations where two or more of the PIIX4E power planes are connected together. It also shows timings when RSMRST# and PWROK are connected together.

Figure 25. Core Well Power and PWROK Activated Signals (Core Well Power Applied before RSMRST# Inactive)

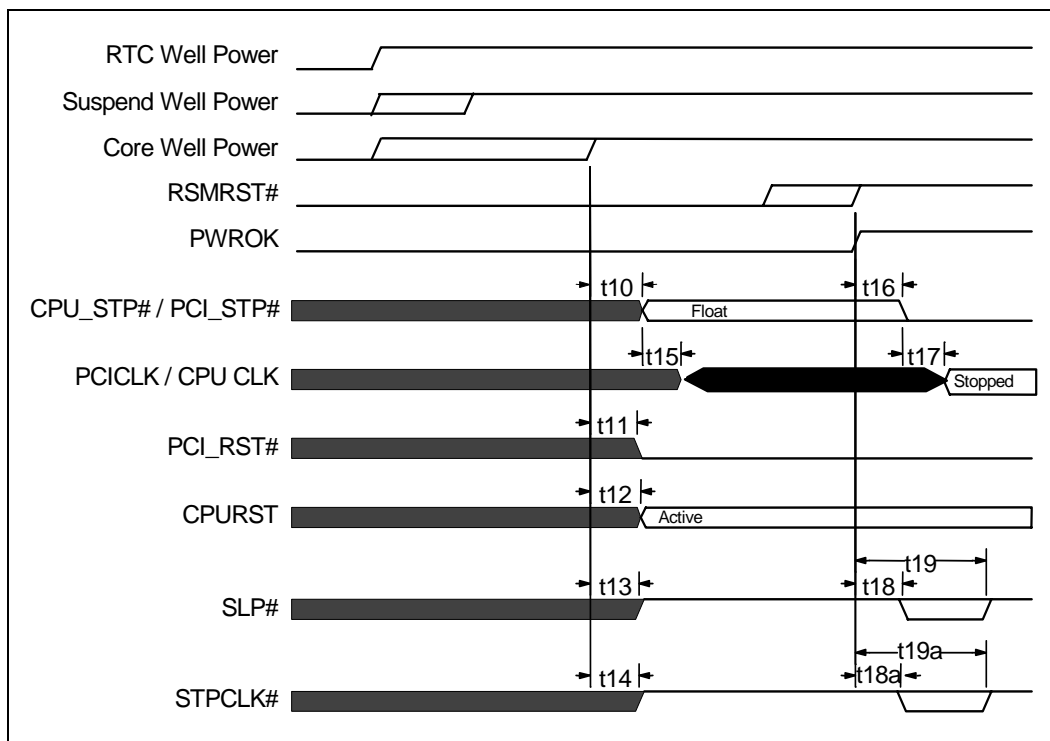

Table 35. Core Well Power and PWROK Timing

Sym	Parameter	Min	Max	Unit	Notes
t10	Core Well Power and PWROK Inactive to CPU_STP# and PCI_STP# Float		1	RTC	1
t11	Core Well Power and PWROK Inactive to PCIRST# Active		1	RTC	1
t12	Core Well Power and PWROK Inactive to CPURST Active		1	RTC	1
t13	Core Well Power and PWROK Inactive to SLP# Inactive		1	RTC	1
t14	Core Well Power and PWROK Inactive to STPCLK# Inactive		1	RTC	1
t15	CPU_STP# and PCI_STP# Float to Clocks Running				2
t16	PWROK Active to CPU_STP# and PCI_STP# Active		1	RTC	1
t17	CPU_STP# and PCI_STP# Active to Clocks Stopped				2
t18	PWROK Active to SLP# Active	0		ns	3
t18a	PWROK Active to STPCLK# Active	0		ns	3
t19	PWROK Active to SLP# Inactive	1	2	RTC	1, 3
t19a	PWROK Active to STPCLK# Inactive	1	2	RTC	1, 3

NOTES:

1. These signals are controlled off an internal RTC clock. One RTC unit is approximately 32 μ s.
2. There are no specific requirements for these timings related to the PIIX4E. The system manufacturer should make sure that the clocks on power up meet any other system specifications. As a minimum, the clocks must be available and stable after time t29 shown in Figure 26.
3. These timings depend on the relative timings between RSMRST# and PWROK. If RSMRST# goes inactive two RTC periods before PWROK active, then SLP# and STPCLK# will remain inactive. If RSMRST# goes inactive less than two RTC periods before PWROK active, then an active pulse will be seen on SLP# and STPCLK#.

7.1.5 Power Management State Transition Timings

7.1.5.1 Mechanical Off to On

Figure 26 shows the transition from a Mechanical Off condition to the On condition.

Figure 26. Mechanical Off to On

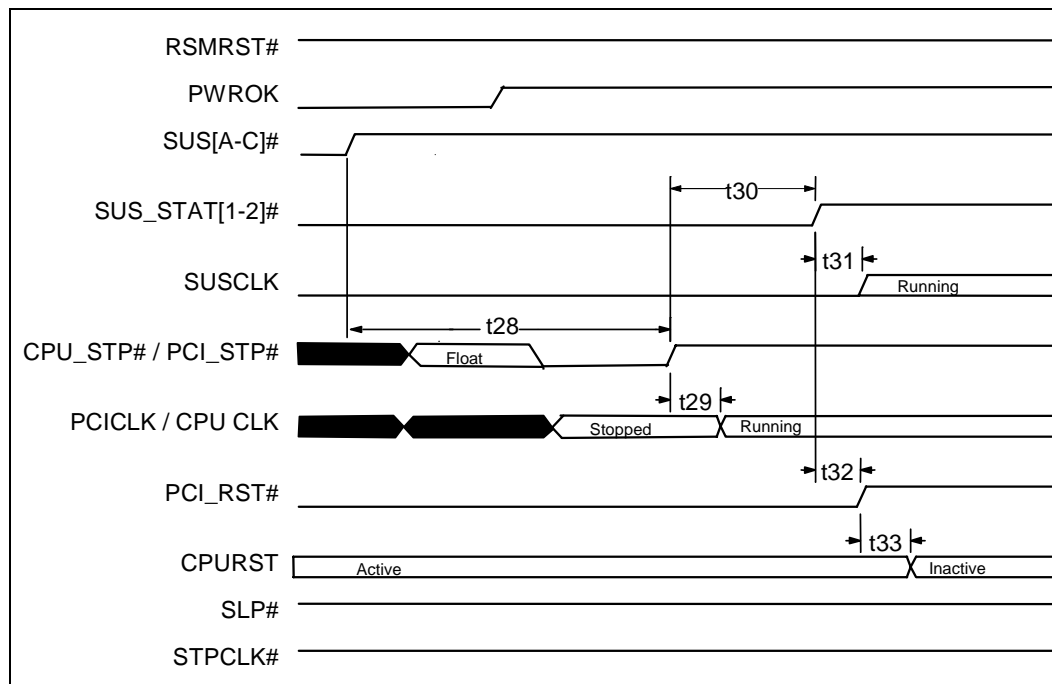

Table 36. Mechanical Off to On Timing

Sym	Parameter	Min	Max	Unit	Notes
t28	SUS[A:C]# Inactive to CPU_STP# and PCI_STP# Inactive	16		ms	1
t29	CPU_STP# and PCI_STP# Inactive to Clocks Running		2	PCICLK	2
t30	CPU_STP# and PCI_STP# Inactive to SUS_STAT[1:2]# Inactive	1		ms	
t31	SUS_STAT[1:2]# Inactive to SUSCLK Running		1	RTC	3
t32	SUS_STAT[1:2]# Inactive to PCI_RST# Inactive		1	RTC	3
t33	PCI_RST# Inactive to CPURST Inactive		1	RTC	3

NOTES:

1. This transition requires a minimum of 16 ms wait for the clock synthesizer PLL to lock and PWROK to be active. If PWROK goes active after 16 ms from SUS[A:C]# inactive, the transition occurs a minimum of one RTC period from PWROK active.
2. See Table 22 and Table 23 for exact PCICLK requirements for use with PC/PCI DMA and Serial IRQs.
3. These signals are controlled from an internal RTC clock. One RTC unit is approximately 32 μ s.

7.1.5.2 On to POS

Figure 27 describes the signal transitions from the On state to the Power On Suspend state.

Figure 27. On to POS

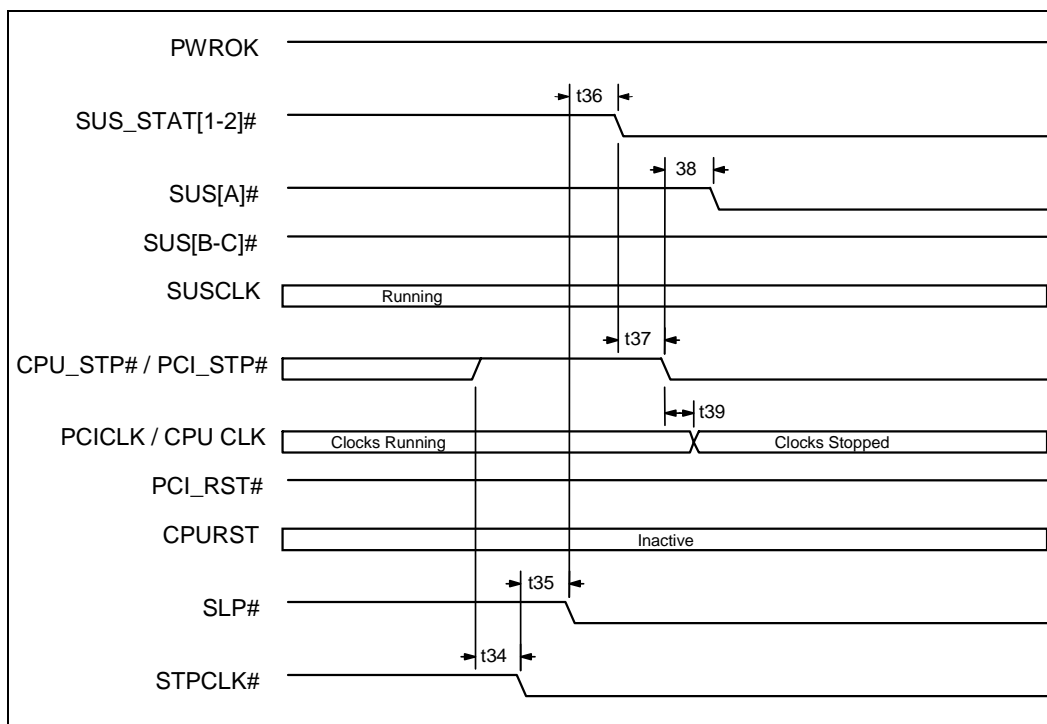

Table 37. On to POS Timing

Sym	Parameter	Min	Max	Unit	Notes
t34	CPU_STP# and PCI_STP# Inactive to STPCLK# Active	1		RTC	1, 2
t35	STPCLK# Active to SLP# Active	1		RTC	1, 3
t36	SLP# Active to SUS_STAT[1:2]# Active		1	RTC	1
t37	SUS_STAT[1:2]# Active to CPU_STP# and PCI_STP# Active		1	RTC	1
t38	CPU_STP# and PCI_STP# Active to SUS[A]# Active		1	RTC	1
t39	CPU_STP# and PCI_STP# Active to Clocks Stopped (if applicable)		2	PCICLK	4, 5

NOTES:

1. These signals are controlled from an internal RTC clock. One RTC unit is approximately 32 μ s.
2. CPU_STP# and PCI_STP# will only be active when the system is under clock control.
3. This transition waits for the Stop Grant cycle to execute.
4. It is up to the system vendor to determine whether CPU_STP# and PCI_STP# signals are used to control system clocks.
5. See Table 22 and Table 23 for exact PCICLK requirements for use with PC/PCI DMA and Serial IRQs.

7.1.5.3 POS to On (with Processor and PCI Reset)

Figure 28 describes the system transition from Power On Suspend to On with a full system reset.

Figure 28. POS to On (with Processor and PCI Reset)

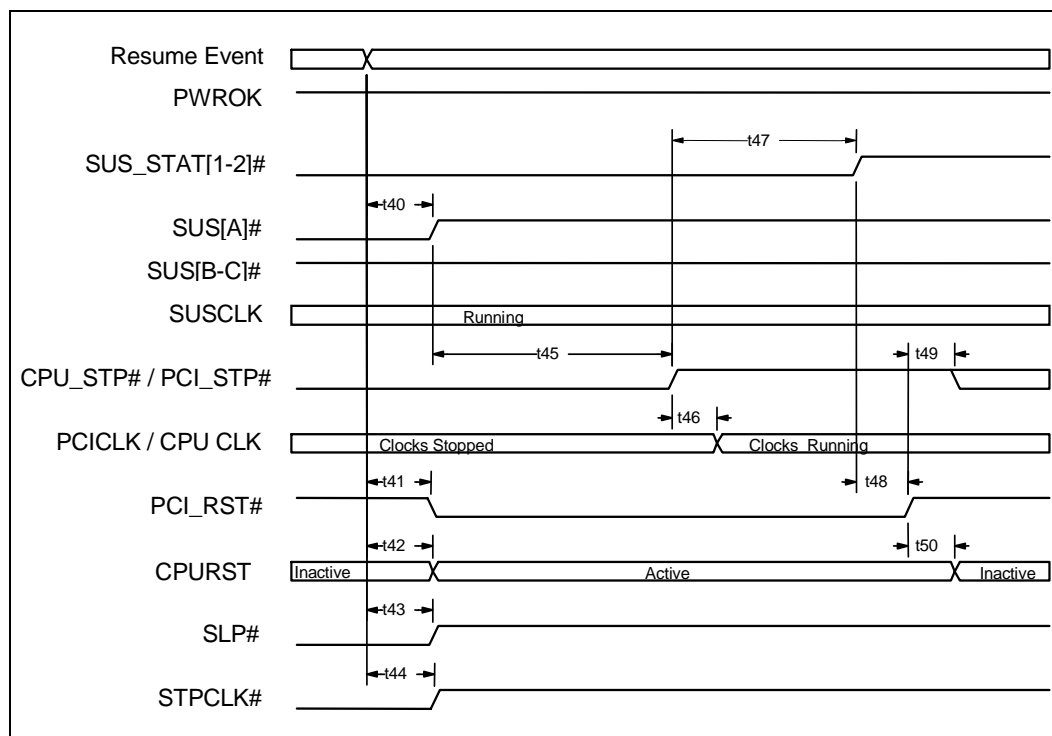

Table 38. POS to On Timing

Sym	Parameter	Min	Max	Unit	Notes
t40	Resume Event to SUS[A]# Inactive	1		RTC	1
t41	Resume Event to PCI_RST# Active	1		RTC	1
t42	Resume Event to CPURST Active	1		RTC	1
t43	Resume Event to SLP# Inactive	1		RTC	1
t44	Resume Event to STPCLK# Inactive	1		RTC	1
t45	SUS[A]# Inactive to PCI_STP# and CPU_STP# Inactive	16		ms	2
t46	PCI_STP# and CPU_STP# Inactive to Clocks Running		2	PCICLK	3
t47	PCI_STP# and CPU_STP# Inactive to SUS_STAT[1:2]# Inactive	1		ms	
t48	SUS_STAT[1:2]# Inactive to PCI_RST# Inactive		1	RTC	1
t49	PCI_RST# Inactive to PCI_STP# and CPU_STP# allowed to change		1	RTC	1
t50	PCI_RST# Inactive to CPURST Inactive		1	RTC	1

NOTES:

1. These signals are controlled from an internal RTC clock. One RTC unit is approximately 32 μ s.
2. This transition requires a minimum of 16 ms wait for the clock synthesizer PLL to lock and PWROK to be active. If PWROK goes active after 16 ms from SUS[A:C]# inactive, the transition will occur a minimum of one RTC period from PWROK active. PWROK remains active throughout POS system usage.
3. See Table 22 and Table 23 for exact PCICLK requirements for use with PC/PCI DMA and Serial IRQs.

7.1.5.4 POS to On (with Processor Reset)

Figure 29 describes the system transition from Power On Suspend (POS) to On with only a processor reset.

Figure 29. POS to On (with Processor Reset)

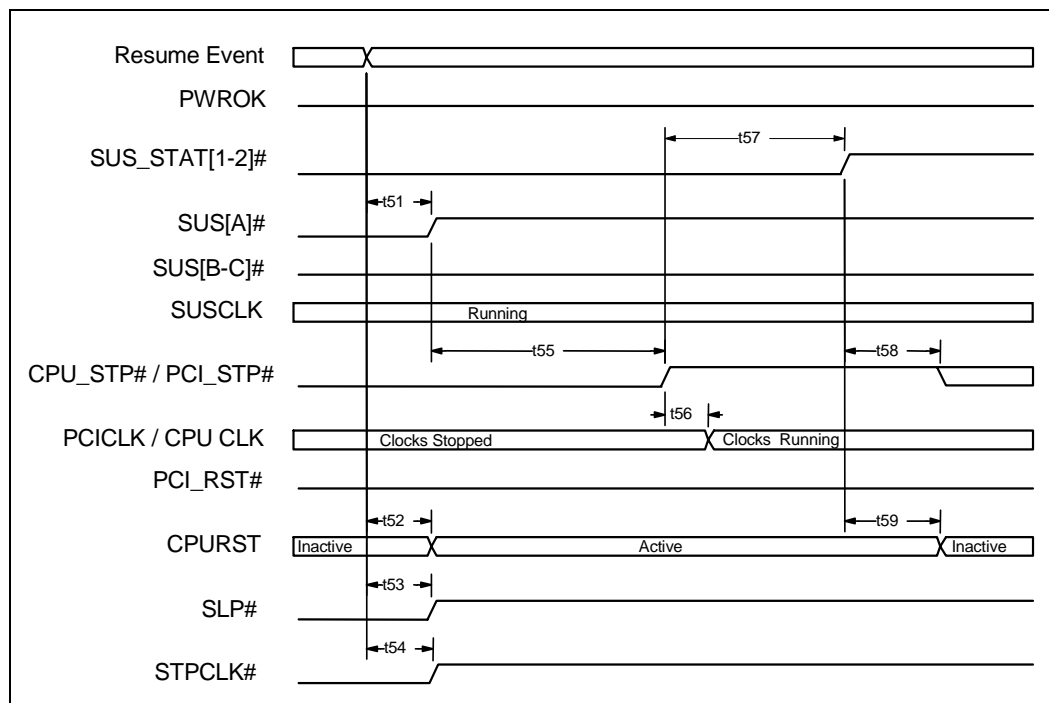

Table 39. POS to On (with Processor Reset) Timing

Sym	Parameter	Min	Max	Unit	Notes
t51	Resume Event to SUS[A]# Inactive	1		RTC	1
t52	Resume Event to CPURST Active	1		RTC	1
t53	Resume Event to SLP# Inactive	1		RTC	1
t54	Resume Event to STPCLK# Inactive	1		RTC	1
t55	SUS[A]# Inactive to PCI_STP# and CPU_STP# Inactive	16		ms	2
t56	PCI_STP# and CPU_STP# Inactive to Clocks Running		2	PCICLK	3
t57	PCI_STP# and CPU_STP# Inactive to SUS_STAT[1:2]# Inactive	1		ms	
t58	SUS_STAT[1:2]# Inactive to PCI_STP# and CPU_STP# allowed to change		2	RTC	1
t59	SUS_STAT[1:2]# Inactive to CPURST Inactive		2	RTC	1

NOTES:

1. These signals are controlled from an internal RTC clock. One RTC unit is approximately 32 μ s.
2. This transition requires both a minimum of 16 ms wait for the clock synthesizer PLL to lock and PWROK to be active. If PWROK goes active after 16 ms from SUS[A:C]# inactive, the transition will occur a minimum of one RTC period from PWROK active. PWROK remains active throughout POS system usage.
3. See Table 22 and Table 23 for exact PCICLK requirements for use with PC/PCI DMA and Serial IRQs.

7.1.5.5 POS to On (No Reset)

Figure 30 describes the system transition from Power On Suspend to On with no resets performed.

Figure 30. POS to On (No Reset)

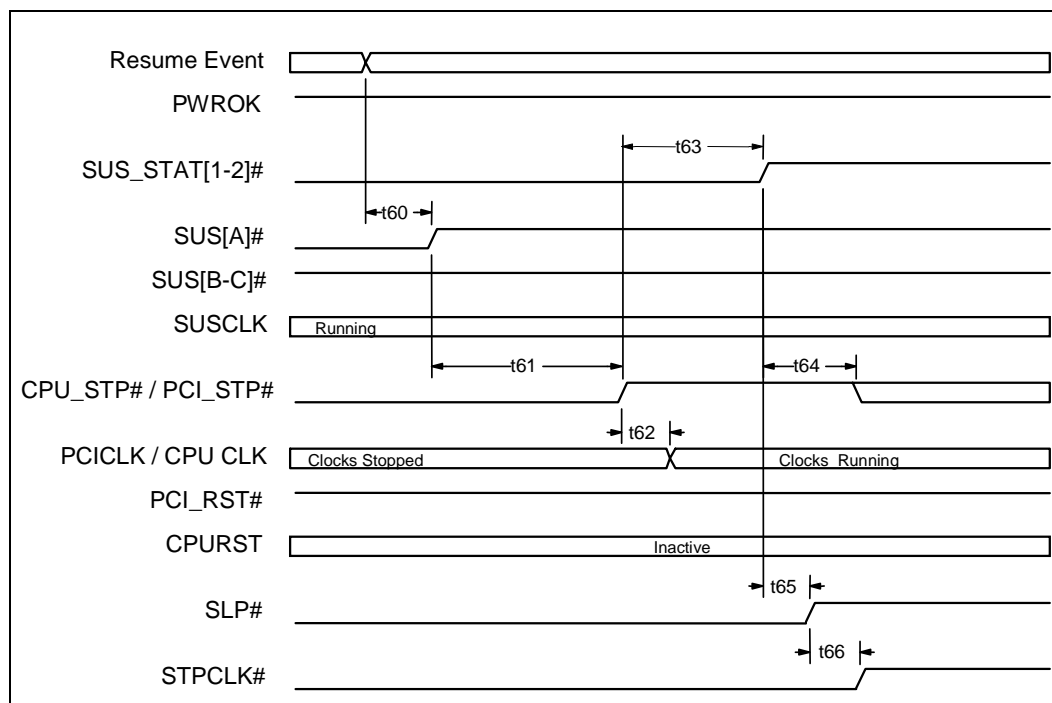

Table 40. POS to On (No Reset) Timing

Sym	Parameter	Min	Max	Unit	Notes
t60	Resume Event to SUS[A]# Inactive	1		RTC	1
t61	SUS[A]# Inactive to PCI_STP# and CPU_STP# Inactive	16		ms	2
t62	PCI_STP# and CPU_STP# Inactive to Clocks Running		2	PCICLK	3
t63	PCI_STP# and CPU_STP# Inactive to SUS_STAT[1:2]# Inactive	1		ms	
t64	SUS_STAT[1:2]# Inactive to PCI_STP# and CPU_STP# allowed to change		2	RTC	1
t65	SUS_STAT[1:2]# Inactive to SLP# Inactive		1	RTC	1
t66	SLP# Inactive to STPCLK# Inactive		1	RTC	1

NOTES:

1. These signals are controlled from the internal RTC clock. One RTC is approximately 32 μ s.
2. This transition requires both a minimum of 16 ms wait for the clock synthesizer PLL to lock and PWROK to be active. If PWROK goes active after 16 ms from SUS[A:C]# inactive, the transition will occur a minimum of one RTC period from PWROK active. PWROK remains active throughout POS system usage.
3. See Figure 22 and Figure 23 for exact PCICLK requirements for use with PC/PCI DMA and Serial IRQs.

7.1.5.6 On to STR

Figure 31 describes the signal transitions from On state to Suspend to RAM state.

Figure 31. On to STR

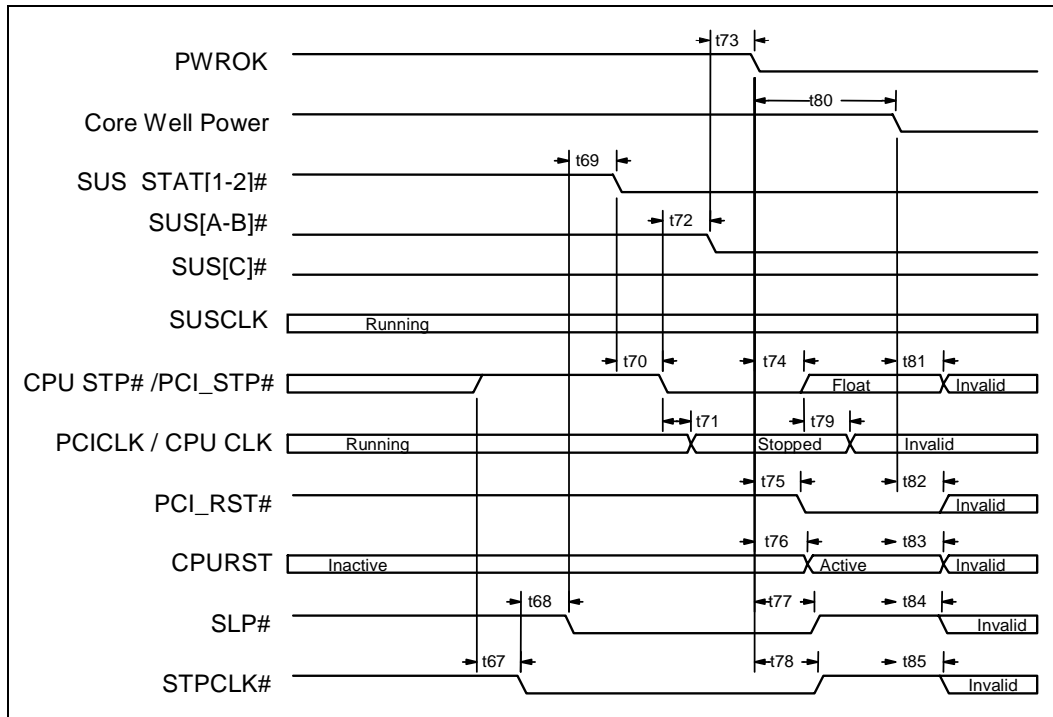

Table 41. On to STR Timing

Sym	Parameter	Min	Max	Unit	Notes
t67	CPU_STP# and PCI_STP# Inactive to STPCLK# Active	1		RTC	1, 2
t68	STPCLK# Active to SLP# Active	1		RTC	1, 3
t69	SLP# Active to SUS_STAT[1:2]# Active		1	RTC	1
t70	SUS_STAT[1:2]# Active to CPU_STP# and PCI_STP# Active		1	RTC	1
t71	CPU_STP# and PCI_STP# Active to CLOCKS Stopped		2	PCICLK	4, 5
t72	CPU_STP# and PCI_STP# Inactive to SUS[A:B]# Active		1	RTC	1
t73	SUS[A:B]# Active to PWROK Inactive	0		ns	6
t74	PWROK Inactive to CPU_STP# and PCI_STP# Float		1	RTC	1
t75	PWROK Inactive to PCI_RST# Active		1	RTC	1
t76	PWROK Inactive to CPURST Active		1	RTC	1
t77	PWROK Inactive to SLP# Inactive		1	RTC	1
t78	PWROK Inactive to STPCLK# Inactive		1	RTC	1
t79	CPU_STP# and PCI_STP# Float to Clocks Invalid	0		ns	7
t80	PWROK Inactive to Core Well Power Removed	0		ns	
t81	Core Well Power Removed to PCI_STP# and CPU_STP# Invalid	0		ns	
t82	Core Well Power Removed to PCIRST# Invalid	0		ns	
t83	Core Well Power Removed to CPURST Invalid	0		ns	
t84	Core Well Power Removed to SLP# Invalid	0		ns	
t85	Core Well Power Removed to STPCLK# Invalid	0		ns	

NOTES:

1. These signals are controlled from the internal RTC clock. One RTC is approximately 32 μ s.
2. CPU_STP# and PCI_STP# will only be active if the system is under clock control.
3. This transition will also wait for the Stop Grant cycle to execute.
4. It is up to the system vendor to determine if CPU_STP# and PCI_STP# signals are used to control system clocks.
5. See Figure 22 and Figure 23 for exact PCICLK requirements for use with PC/PCI DMA and Serial IRQs.
6. It is up to the system vendor to determine if SUS[A:B]# signals are used to control system power planes. If power remains applied to system board and PWROK stays active during STR, the PII4E signals will remain in the states shown after t73.
7. Clocks may or may not be running depending on the condition of the Power Supply voltages.

7.1.5.7 STR to On

Figure 32 describes the system transition from Suspend To RAM to On with a full system reset.

Figure 32. STR to On

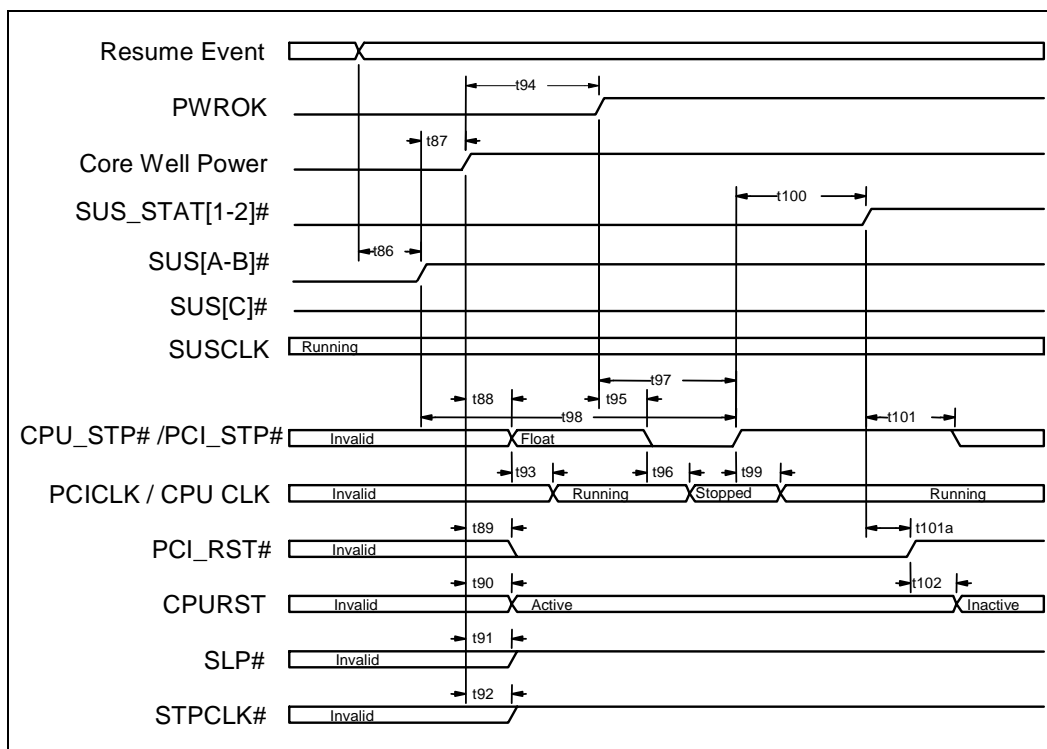

Table 42. STR to On Timing (Sheet 1 of 2)

Sym	Parameter	Min	Max	Unit	Notes
t86	Resume Event to SUS[A:B]# Inactive	1		RTC	1
t87	SUS[A:B]# Inactive to Core Well Power Applied	0		ns	
t88	Core Well Power Applied to PCI_STP# and CPU_STP# Float	0		ns	
t89	Core Well Power Applied to PCI_RST# Active	0		ns	
t90	Core Well Power Applied to CPURST Active	0		ns	
t91	Core Well Power Applied to SLP# Inactive	0		ns	
t92	Core Well Power Applied to STPCLK# Inactive	0		ns	
t93	PCI_STP# and CPU_STP# Float to Clocks Running				2
t94	Core Well Power Applied to PWROK Active	1		ms	

NOTES:

1. These signals are controlled from the internal RTC clock. One RTC is approximately 32 μ s.
2. There are no specific requirements for these timings related to the PIIX4E. The system manufacturer should make sure that the clocks meet any other system specifications upon power up. At a minimum, the clocks must be available and stable after time t99.
3. See Figure 22 and Figure 23 for exact PCICLK requirements for use with the PC/PCI DMA and Serial IRQs.

Table 42. STR to On Timing (Sheet 2 of 2)

Sym	Parameter	Min	Max	Unit	Notes
t95	PWROK Active to CPU_STP# and PCI_STP# Active	0		ns	
t96	PCI_STP# and CPU_STP# Active to Clocks Stopped		2	PCICLK	3
t97	PWROK Active to CPU_STP# and PCI_STP# Inactive	1		RTC	1
t98	SUS[A-B]# Inactive to CPU_STP# and PCI_STP# Inactive	16		ms	
t99	CPU_STP# and PCI_STP# Inactive to Clocks Running		2	PCICLK	3
t100	CPU_STP# and PCI_STP# Inactive to SUS_STAT[1-2]# Inactive	1		ms	
t101	SUS_STAT[1-2]# Inactive to CPU_STP# and PCI_STP# allowed to change	2		RTC	1
t101a	SUS_STAT[1-2]# Inactive to PCI_RST# Inactive	1		RTC	1
t102	PCI_RST# Inactive to CPURST Inactive	1		RTC	1

NOTES:

1. These signals are controlled from the internal RTC clock. One RTC is approximately 32 μ s.
2. There are no specific requirements for these timings related to the PIIX4E. The system manufacturer should make sure that the clocks meet any other system specifications upon power up. At a minimum, the clocks must be available and stable after time t99.
3. See Figure 22 and Figure 23 for exact PCICLK requirements for use with the PC/PCI DMA and Serial IRQs.

7.1.5.8 On to STD/SOff

Figure 33 describes the signal transitions from the On state to the Suspend to Disk/Soft Off state.

Figure 33. On to STD/SOff

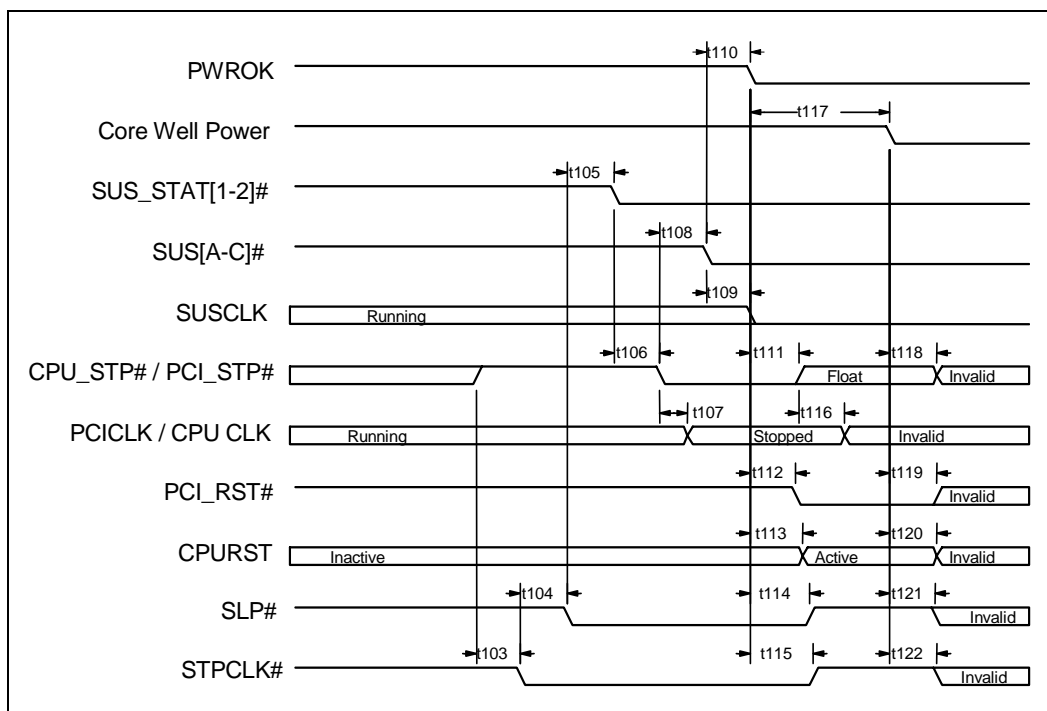

Table 43. On to STD/SOff Timing (Sheet 1 of 2)

Sym	Parameter	Min	Max	Unit	Notes
t103	CPU_STP# and PCI_STP# Inactive to STPCLK# Active	1		RTC	1, 2
t104	STPCLK# Active to SLP# Active	1		RTC	1, 3
t105	SLP# Active to SUS_STAT[1:2]# Active		1	RTC	1
t106	SUS_STAT[1:2]# Active to CPU_STP# and PCI_STP# Active		1	RTC	1
t107	CPU_STP# and PCI_STP# Inactive to CLOCKS Stopped		2	PCICLK	1, 4, 5
t108	CPU_STP# and PCI_STP# Inactive to SUS[A:C]# Active		1	RTC	1

NOTES:

1. These signals are controlled from the internal RTC clock. One RTC is approximately 32 μ s.
2. CPU_STP# and PCI_STP# will only be active if the system is under clock control.
3. This transition will also wait for the Stop Grant cycle to execute.
4. It is up to the system vendor to determine if CPU_STP# and PCI_STP# signals are used to control system clocks.
5. See Figure 22 and Figure 23 for exact PCICLK requirements for use with the PC/PCI DMA and Serial IRQs.
6. It is up to the system vendor to determine if SUS[A:C]# signals are used to control system power planes. If the power remains applied to the system board and the PWROK stays active during STD, the PIIX4E signals will remain in the states shown after t110.

Table 43. On to STD/SOff Timing (Sheet 2 of 2)

Sym	Parameter	Min	Max	Unit	Notes
t109	SUS[A:C]# Active to SUSCLK Low		1	RTC	1
t110	SUS[A:C]# Active to PWROK Inactive	0		ns	6
t111	PWROK Inactive to CPU_STP# and PCI_STP# Float		1	RTC	1
t112	PWROK Inactive to PCI_RST# Active		1	RTC	1
t113	PWROK Inactive to CPURST Active		1	RTC	1
t114	PWROK Inactive to SLP# Inactive		1	RTC	1
t115	PWROK Inactive to STPCLK# Inactive		1	RTC	1
t116	CPU_STP# and PCI_STP# Float to Clocks Invalid	0		ns	1
t117	PWROK Inactive to Core Well Power Removed	0		ns	
t118	Core Well Power Removed to PCI_STP# and CPU_STP# Invalid	0		ns	
t119	Core Well Power Removed to PCIRST# Invalid	0		ns	
t120	Core Well Power Removed to CPURST Invalid	0		ns	
t121	Core Well Power Removed to SLP# Invalid	0		ns	
t122	Core Well Power Removed to STPCLK# Invalid	0		ns	

NOTES:

1. These signals are controlled from the internal RTC clock. One RTC is approximately 32 μ s.
2. CPU_STP# and PCI_STP# will only be active if the system is under clock control.
3. This transition will also wait for the Stop Grant cycle to execute.
4. It is up to the system vendor to determine if CPU_STP# and PCI_STP# signals are used to control system clocks.
5. See Figure 22 and Figure 23 for exact PCICLK requirements for use with the PC/PCI DMA and Serial IRQs.
6. It is up to the system vendor to determine if SUS[A:C]# signals are used to control system power planes. If the power remains applied to the system board and the PWROK stays active during STD, the PIIX4E signals will remain in the states shown after t110.

7.1.5.9 STD/SOff to On

Figure 34 describes the system transition from Suspend To Disk to On with a full system reset.

Figure 34. STD/SOff to On

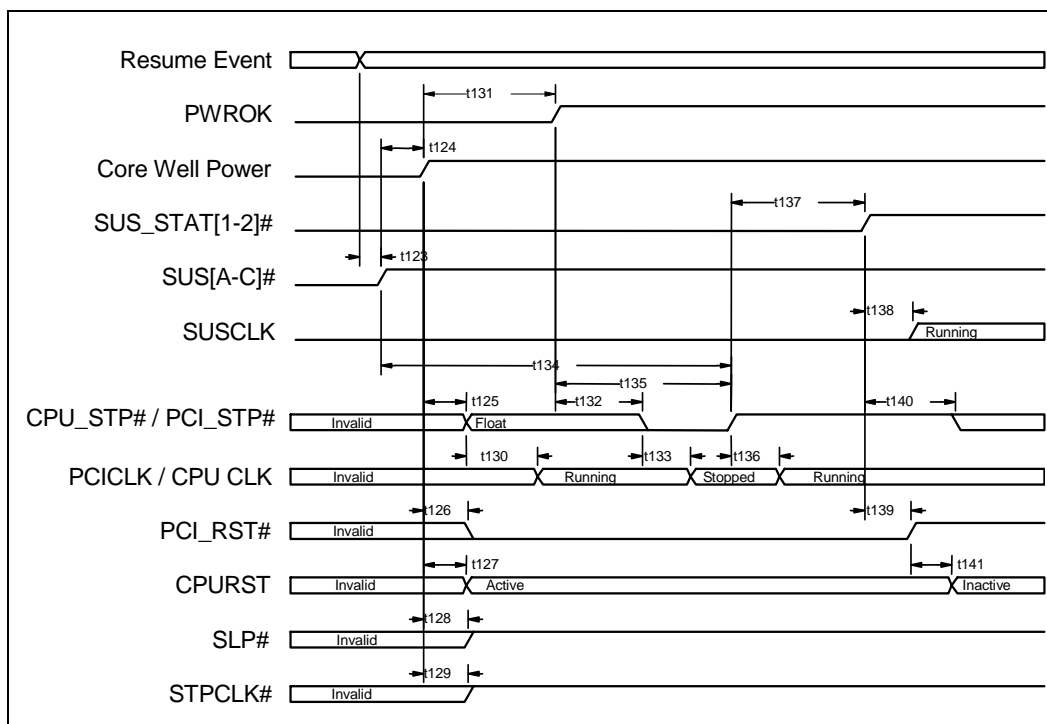

Table 44. STD/SOff to On Timing (Sheet 1 of 2)

Sym	Parameter	Min	Max	Unit	Notes
t123	Resume Event to SUS[A:C]# Inactive	1		RTC	1
t124	SUS[A-C]# Inactive to Core Well Power Applied	0		ns	
t125	Core Well Power Applied to PCI_STP# and CPU_STP# Float	0		ns	
t126	Core Well Power Applied to PCI_RST# Active	0		ns	
t127	Core Well Power Applied to CPURST Active	0		ns	
t128	Core Well Power Applied to SLP# Inactive	0		ns	
t129	Core Well Power Applied to STPCLK# Inactive	0		ns	
t130	PCI_STP# and CPU_STP# Float to Clocks Running				2
t131	Core Well Power Applied to PWROK Active	1		ms	

1. These signals are controlled from the internal RTC clock. One RTC is approximately 32 μ s.
2. There are no specific requirements for these timings related to the PIIX4E. The system manufacturer should make sure that the clocks on power up meet any other system specifications. At a minimum, the clocks must be available and stable after time t136.
3. See Figure 22 and Figure 23 for exact PCICLK requirements for use with the PC/PCI DMA and Serial IRQs.

Table 44. STD/SOff to On Timing (Sheet 2 of 2)

Sym	Parameter	Min	Max	Unit	Notes
t132	PWROK Active to CPU_STP# and PCI_STP# Active	0		ns	
t133	PCI_STP# and CPU_STP# Active to Clocks Stopped		2	PCICLK	3
t134	SUS[A-C]# Inactive to CPU_STP# and PCI_STP# Inactive	16		ms	
t135	PWROK Active to CPU_STP# and PCI_STP# Inactive	1		RTC	1
t136	PCI_STP# and CPU_STP# Active to Clocks Running	1	2	PCICLK	3
t137	CPU_STP# and PCI_STP# Inactive to SUS_STAT[1:2]# Inactive	1		ms	
t138	SUS_STAT[1:2]# Inactive to SUSCLK Running		1	RTC	1
t139	SUS_STAT[1:2]# Inactive to PCI_RST# Inactive	1		RTC	1
t140	SUS_STAT[1:2]# Inactive to CPU_STP# and PCI_STP# allowed to change	2		RTC	1
t141	PCI_RST# Inactive to CPURST Inactive	1		RTC	1

1. These signals are controlled from the internal RTC clock. One RTC is approximately 32 μ s.
2. There are no specific requirements for these timings related to the PIIX4E. The system manufacturer should make sure that the clocks on power up meet any other system specifications. At a minimum, the clocks must be available and stable after time t136.
3. See Figure 22 and Figure 23 for exact PCICLK requirements for use with the PC/PCI DMA and Serial IRQs.

7.2 82443BX Host Bridge Controller Power Sequencing

7.2.1 Power Sequencing Requirements

In systems requiring 5-V tolerance, the REFVCC5 signal must be tied to 5-V. This signal must power up before or simultaneous to V_{CC} . It must power down after or simultaneous to V_{CC} . In a non-5-V tolerant system (3.3-V only), this signal can be tied directly to V_{CC} . There are then no sequencing requirements. Refer to Figure 35 for an example circuit schematic that may be used to ensure the proper REFVCC5 sequencing. This is the same circuit that is recommended for the PIIX4E VREF supply. However, different power planes may supply the PIIX4E core and the 82443BX Host Bridge controller (the PIIX4E core may be powered down during STR). In this case a separate circuit must be used for each of the two devices.

V_{CC} must power up before or simultaneous to the AGP supplies (V_{CC_AGP} and AGP_REF) and Low Power GTL+ supplies (V_{TT} and GTL_REF). V_{CC} must power down after or simultaneous to the AGP and Low Power GTL+ supplies. The AGP and Low Power GTL+ supplies must not be powered up while V_{CC} is powered down. There are no other power sequencing requirements for the 82443BX Host Bridge controller.

Figure 35. REFVCC5 Supply Circuit Schematic

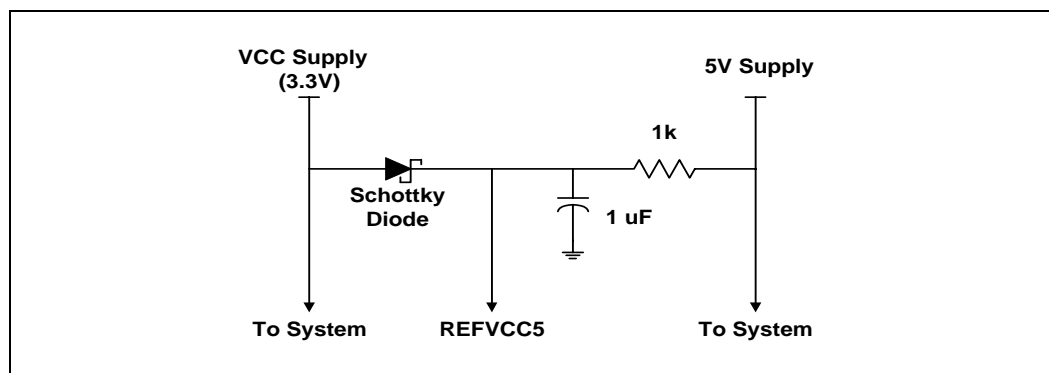

7.2.2 440BX AGPset Power Management

The 440BX AGPset supports a variety of system-wide low-power modes using the following functions:

- Hardware interface with the PIIX4E that is used to indicate:
 - Suspend mode entry
 - Resume from suspend
 - Whether to automatically switch from suspend to normal refresh
- Automatic transition from normal to suspend refresh
- Optional automatic transition from suspend to normal refresh
- Optional CPU reset during resume from Power On Suspend (POS)
- Variety of Suspend refresh types:
 - Self Refresh for SDRAMs
 - Optional Self Refresh for EDO
 - Optional CAS Before RAS (CBR) refresh for EDO. An Integrated Ring oscillator is used to provide the time base for the associated logic.
 - Programmable slow refresh (relevant for CBR refresh only)
- Isolated I/O pins to significantly reduce power consumption while in POS and STR modes

Based on the above functions, the 440BX AGPset recognizes the following system-wide low power modes:

- STR and POS suspend entry and exit are generally handled in the same manner. The following exceptions are related to POS mode:
 - The POS resume sequence may or may not include a processor reset. STR, with PCIRST# active always includes a processor reset.
 - The POS resume sequence requires a hardware transition from suspend to a normal refresh. STR with PCIRST# active requires a software initiated transition.
- STD resume is handled in the same way as the power on sequence, including a complete reset of the 440BX AGPset state.

7.2.2.1 System Power Modes

The following table provides an overview of how the above features map into system-wide low power modes.

Table 45. System-wide Low-power Modes

System Suspend State	82443BX State	Description	POS Exit PCIRST	External Clk	
				HCLK	PCLK
Power On	ON	82443BX is fully on and operating normally. Internal clock gating as well as PCI CLKRUN# may be enabled.	N/A	Active	Active
CPU STOP_GRANT or QUICK_START (C2)	ON	This is transparent to the 82443BX since the external HCLK and PCLK are unaffected. The Host Bus is Idle. Internal clock gating and PCI CLKRUN# may be enabled.	N/A	Active	Active
CPU STOP CLOCK (C3) (DEEP SLEEP)	POS	System PLLs remain powered, but are disabled. HCLK clock is kept low. The only guaranteed running clock is SUSCLK. The 82443BX maintains DRAM refresh using suspend refresh. The 82443BX's internal PLLs are disabled. The 82443BX PCI and AGP arbiters are disabled.	N	Low	Low or Active
Power On Suspend (POS)	POS	System PLLs are powered down. The only running clock is the RTC clock and SUSCLK. The 82443BX maintains DRAM refresh using suspend refresh. The 82443BX's PLLs are disabled. The 82443BX PCI and AGP arbiters are disabled. When resumed, the 82443BX may or may not generate a processor reset. All 82443BX logic, with the exception of resume and refresh, are inactive.	Y	Low	Low
Suspend to RAM (STR)	POS	The processor and other components (with the exception of the DRAM and PIIX4E resume logic) are assumed to be powered OFF. The 82443BX V _{CC} supply is on and all I/O buffers are isolated (with the exception of suspend and DRAM signals). The 82443BX Low Power GTL+ supplies should be powered down with the processor. The 82443BX maintains DRAM refresh using a suspend refresh. All 82443BX logic, with the exception of resume and refresh, are inactive.	Y	Low	Low
Suspend -to-Disk (STD) or Powered-Off	OFF	The entire system is powered OFF except for the PIIX4E resume and RTC wells. Upon resume, the 82443BX resets its entire state.	N/A	X	X

NOTE: The processor will generally be powered off during STR (the processor voltage regulator will be controlled by the PIIX4E's SUSB# signal). In this case, the 82443BX Low Power GTL+ supply (VTT and GTL_REF) should also be controlled by SUSB#, and hence be powered off during STR.

7.2.2.2 System Power-up Sequencing

The following waveforms show the powerup sequence and timing information for the 440BX AGPset.

Figure 36. System Power-up Sequencing

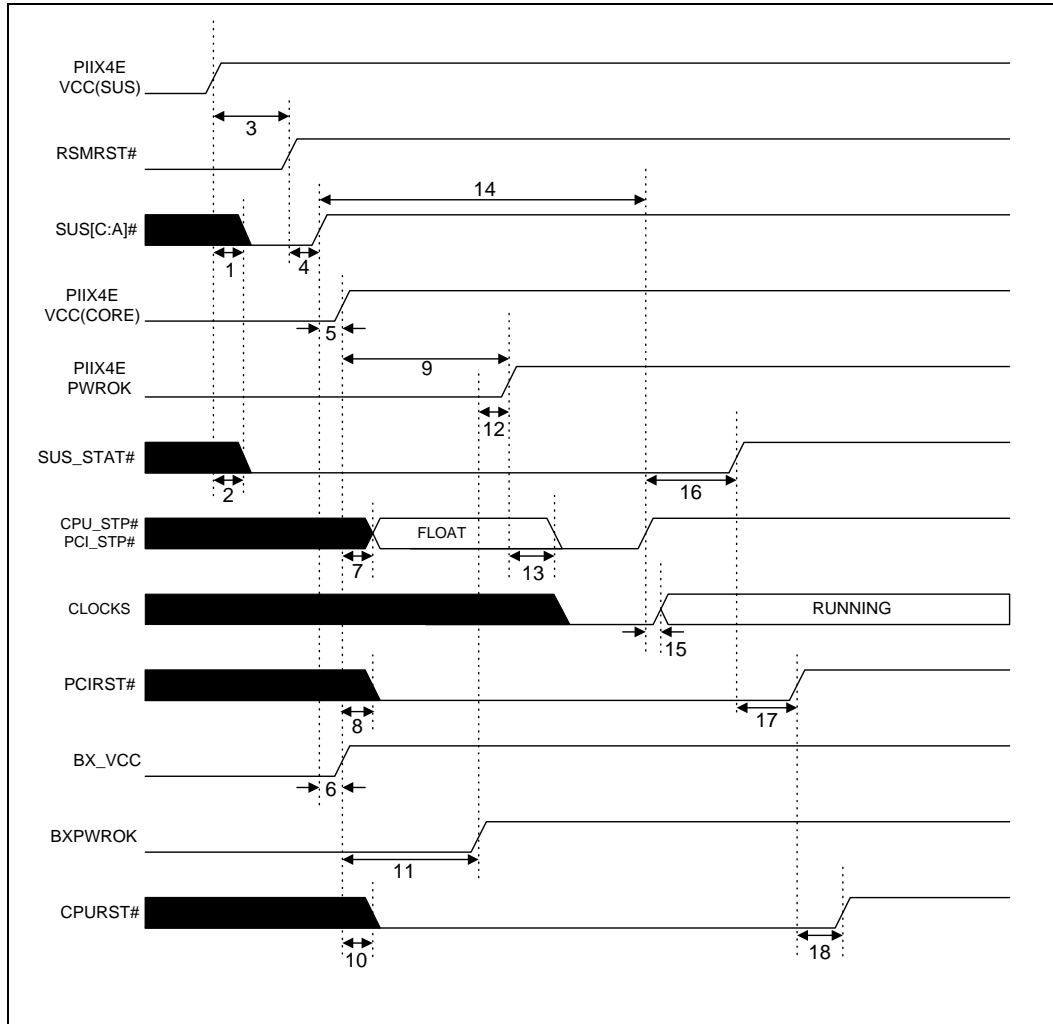

Table 46. System Power-up Sequencing Timing

Sym	Parameter	Min	Max	Units	Notes
t ₁	PIIX4E VCC(SUS) nominal to SUS[C:A]# active		1	RTC	1
t ₂	PIIX4E VCC(SUS) nominal to SUS_STAT[2:1]# active		1	RTC	1
t ₃	PIIX4E VCC(SUS) nominal to RSMRST# active	1		ms	
t ₄	RSMRST# inactive to SUS[C:A]# inactive	1	2	RTC	1
t ₅	SUS[B]# inactive to PIIX4E VCC(CORE) nominal	0		ms	
t ₆	SUS[C]# inactive to BX_VCC nominal	0		ms	
t ₇	PIIX4E VCC(CORE) nominal to CPU_STP#, PCI_STP# float		1	RTC	1
t ₈	PIIX4E VCC(CORE) nominal to PCIRST# active		1	RTC	1
t ₉	PIIX4E VCC(CORE) nominal to PIIX4E PWROK active	1		ms	
t ₁₀	BX_VCC nominal to CPURST# active		10	ns	
t ₁₁	BX_VCC nominal to BXPWROK active	1		ms	
t ₁₂	BXPWROK active to PIIX4E PWROK active	0		ns	2
t ₁₃	PIIX4E PWROK active to CPU_STP#, PCI_STP# active		1	RTC	1
t ₁₄	SUS[C:A]# inactive to CPU_STP#, PCI_STP# inactive	16		ms	3
t ₁₅	CPU_STP#, PCI_STP# inactive to clocks running		2	PCICLK	
t ₁₆	CPU_STP#, PCI_STP# inactive to SUS_STAT[2:1]# inactive	1		ms	
t ₁₇	SUS_STAT[2:1]# inactive to PCIRST# inactive		1	RTC	1
t ₁₈	PCIRST# inactive to CPURST# inactive	1		ms	

NOTES:

1. One RTC unit is approximately 32 μs
2. This parameter only applies if BXPWROK will not transition to an active state within 15 ms of SUS[C:A]# de-assertion
3. This transition requires both a minimum of 16 ms wait for the clock synthesizer PLL lock and PIIX4 PWROK to be active. If PWROK goes active after 16 ms from SUS[C:A]# inactive, the transition will occur a minimum of one RTC period from PWROK active.

7.2.2.3 Suspend Resume Protocols

The suspend resume sequences are indicated to the 82443BX by the PIIX4E, using SUS_STAT# and PCIRST#. In addition, the 82443BX contains NREF_EN and CRst_En configuration bits that participate in the suspend resume sequences.

As a result of suspend resume, the 82443BX performs the following activities:

- Changing its refresh mode
- Performing internal and processor reset
- Isolate or re-enable normal IO buffers

Table 47 describes the suspend resume events and activities.

Table 47. Suspend Resume Events And Activities

SUSSTAT#	PCIRST#	CrstEn	Reset	Refresh	I/O Buffers
Assert	Inactive	-	-	Switch to suspend refresh	Isolate
Deassert	Active	-	Reset exclude resume/ref logic	Suspend refresh NREF_EN remains inactive	Enable
Deassert	Inactive	0	No resets	Auto switch to normal ref NREF_EN is set	Enable
Deassert	Inactive	1	Reset processor only	Auto switch to normal ref NREF_EN is set	Enable

The requirements for suspending the 82443BX are:

- The system must be idle when SUS_STAT# is asserted. There must be no active processor or bus masters' cycles and there must be no meaningful pending cycle's information in a chipset or peripheral device's buffers.
- After the assertion of SUS_STAT#, the PIIX4E provides the 82443BX 32 μ s with stable power and clocks to perform the necessary suspend sequence.
- The PCICLK must not be stopped with CLKRUN# during the suspend sequence.
- The 82443BX isolates its IO buffers within less than 32 μ s time allocated from SUS_STAT# assertion.
 - The 82443BX does not isolate PCIRST# (being pulled up) or clock inputs. The clock inputs are driven low by the clock synthesizer, and 32 μ s later the clock synthesizer device may be powered down.

The requirements for resuming the 82443BX are:

- Power and clocks must be stable for at least 1 ms before SUS_STAT# is deasserted.
- When resuming from POS, STPCLK# remains active for about 100 μ s after SUS_STAT# deassertion, to allow an automatic switch to normal DRAM operation before processor pending cycles take place.

The 82443BX provides isolation of its I/O buffers during POS and STR. During the events that were specified in Table 47, the isolation takes effect. Table 48 provides information about the state of each of the 82443BX signals during POS and STR.

Table 48. 443BX Signal States During POS and STR Modes (Sheet 1 of 3)

Signal Name	State During POS/STR
CPURST#	Tri-state
A[31:3]#	Tri-state
HD[63:0]#	Tri-state
ADS#	Tri-state
BNR#	Tri-state
BPRI#	Tri-state
DBSY#	Tri-state
DEFER#	Tri-state
DRDY#	Tri-state
HIT#	Tri-state
HITM#	Tri-state
HLOCK#	
HREQ[4:0]#	Tri-state
HTRDY#	Tri-state
RS[2:0]#	Tri-state
RASA[5:0]# / CSA[5:0]#	High1
RASB[5:0]# / CSB[5:0]#	High1
CKE[3:2] / CSA[7:6]#	Low/High2
CKE[5:4] / CSB[7:6]#	Low/High2
CASA[7:0]# / DQMA[7:0]#	High1
CASB[5,1]# / DQMB[5,1]#	High1
GCKE / CKE1	Low/High2
SRAS[B:A]#	Low/High2
CKE0 / FENA	Low/High2
SCAS[B:A]#	High/Low2
MAA[13:0]	Driven3
MAB[9:7]# / MAB[13,10]	Driven3
MAB[12:11]#	Driven3
MAB[6:0]#	Driven3
WEA#, WEB#	High
MD [63:0]	Driven3
MECC[7:0]	Driven3

NOTES:

1. SDRAM Mode: After putting the SDRAMs into self-refresh mode, these signals are driven high. EDO Mode: For self-refresh mode, RAS and CAS are driven low. Otherwise, the 82443BX continues to refresh during the POS/STR state.
2. SDRAM Mode: SRAS#, SCAS#, CKE[5:0] and GCKE are driven to the first value listed. EDO Mode: These signals are driven to the second value listed.
3. MA lines are always driven by the 82443BX, except for MAB[13:11,9:0]# and MAB10, which are three-stated during reset. MD/MECC are always driven by the 82443BX when there is no active cycle. The values driven on MA, MD and MECC are indeterminate during and after reset.

Table 48. 443BX Signal States During POS and STR Modes (Sheet 2 of 3)

Signal Name	State During POS/STR
AD[31:0]	Low
DEVSEL#	Tri-state
FRAME#	Tri-state
IRDY#	Tri-state
C/BE[3:0]#	Low
PAR	Low
PLOCK#	Tri-state
TRDY#	Tri-state
SERR#	Tri-state
STOP#	Tri-state
PHOLD#	Tri-state
PHLDA#	Tri-state
WSC#	Tri-state
PREQ[4:0]#	Tri-state
PGNT[4:0]#	Tri-state
PIPE#	Tri-state
SBA[7:0]	Tri-state
RBF#	Tri-state
ST[2:0]	Low
AD_STBA	Tri-state
AD_STBB	Tri-state
SB_STB	Tri-state
G_FRAME#	Tri-state
G_IRDY#	Tri-state
G_TRDY#	Tri-state
G_STOP#	Tri-state
G_DEVSEL#	Tri-state
G_REQ#	Tri-state
G_GNT#	Tri-state
G_AD[31:0]	Low
G_C/BE[3:0]#	Low
G_PAR	Low
HCLKIN	

NOTES:

1. SDRAM Mode: After putting the SDRAMs into self-refresh mode, these signals are driven high. EDO Mode: For self-refresh mode, RAS and CAS are driven low. Otherwise, the 82443BX continues to refresh during the POS/STR state.
2. SDRAM Mode: SRAS#, SCAS#, CKE[5:0] and GCKE are driven to the first value listed. EDO Mode: These signals are driven to the second value listed.
3. MA lines are always driven by the 82443BX, except for MAB[13:11,9:0]# and MAB10, which are three-stated during reset. MD/MECC are always driven by the 82443BX when there is no active cycle. The values driven on MA, MD and MECC are indeterminate during and after reset.

Table 48. 443BX Signal States During POS and STR Modes (Sheet 3 of 3)

Signal Name	State During POS/STR
PCLKIN	
DCLKO	Low
DCLKRD	
DCLKWR	
CRESET#	Tri-state
PCIRST#	
GCLKIN	
GCLKO	Low
TESTIN#	
SMBCLK	Tri-state
SMBDATA	Tri-state
CLKRUN#	Tri-state
SUSSTAT#	

NOTES:

1. SDRAM Mode: After putting the SDRAMs into self-refresh mode, these signals are driven high. EDO Mode: For self-refresh mode, RAS and CAS are driven low. Otherwise, the 82443BX continues to refresh during the POS/STR state.
2. SDRAM Mode: SRAS#, SCAS#, CKE[5:0] and GCKE are driven to the first value listed. EDO Mode: These signals are driven to the second value listed.
3. MA lines are always driven by the 82443BX, except for MAB[13:11,9:0]# and MAB10, which are three-stated during reset. MD/MECC are always driven by the 82443BX when there is no active cycle. The values driven on MA, MD and MECC are indeterminate during and after reset.

7.2.2.4 82443BX Suspend/Resume Sequences and Timing

Table 49. Suspend/Resume Timing (Sheet 1 of 2)

Sym	Parameter	Min	Max	Unit
t1	BX_VCC stable to BXPWROK asserted. †	1		ms
t2	BXPWROK asserted to SUS_STAT# inactive	1		ms
t3	Clocks running to SUS_STAT# inactive, guarantee	1		ms
t4	BX_VCC active and BXPWROK inactive to CPURST# active		10	ns
t5	SUS_STAT# deasserted to PCIRST# deasserted, guarantee		32	µs
t6	PCIRST# deasserted to CPURST# deasserted	1		ms
t7	SUS_STAT# deasserted to buffers valid	2		HCLK
t8	SUS_STAT# asserted to clocks stopped, guarantee	32		µs
t9	SUS_STAT# asserted to suspend refresh		32	µs

† "BX_VCC stable" means BX_VCC is within the specified Functional Operating Range.

Table 49. Suspend/Resume Timing (Sheet 2 of 2)

Sym	Parameter	Min	Max	Unit
t10	SUS_STAT# asserted to buffers isolated		32	μs
t11	PCIRST# asserted to CPURST# asserted		10	ns
t12	PCIRST# asserted to SUS_STAT# de-asserted, guarantee	1		ms
t13	SUS_STAT# de-asserted to normal refresh		32	μs
t14	SUS_STAT# de-asserted to CPURST# asserted	0	4	HCLK
t15	CPURST# pulse width	1		ms

† “BX_VCC stable” means BX_VCC is within the specified Functional Operating Range.

7.2.2.5 Suspend/Resume with PCIRST# Active

The following resume sequence is typically used when resuming from STR. It includes the following components:

- BXPWROK must transition from inactive (low) to active (high) a minimum of 1 ms after BX_VCC is within the specified Functional Operating Range.
- When 15 ms or more may elapse from the time that the PIIX4E deasserts SUS[C:A]# until BXPWROK is asserted, BXPWROK must be asserted before or simultaneous to PWROK being asserted to the PIIX4E.
- Upon resume, the 82443BX detects that the PCIRST# signal is active (low) and drives CPURST# to the processor. Note that CPURST# is driven active based on PCIRST# timing, independent of SUS_STAT# timing.
- Based on the assertion of SUS_STAT#, the 82443BX isolates its I/O buffer within 32 μs.
- Based on the deassertion of SUS_STAT#, the 82443BX enables its I/O buffer to normal operation within 32 μs. Clock inputs and PCIRST# are never gated by the 82443BX and thus affect it before the deassertion of SUS_STAT#.
- Software must release the memory controller from its suspend refresh state to its normal refresh state.
- The 82443BX clears its internal state, with the exception of resume/refresh logic, since it sampled PCIRST# asserted.

Figure 37. Suspend/Resume with PCIRST# Active

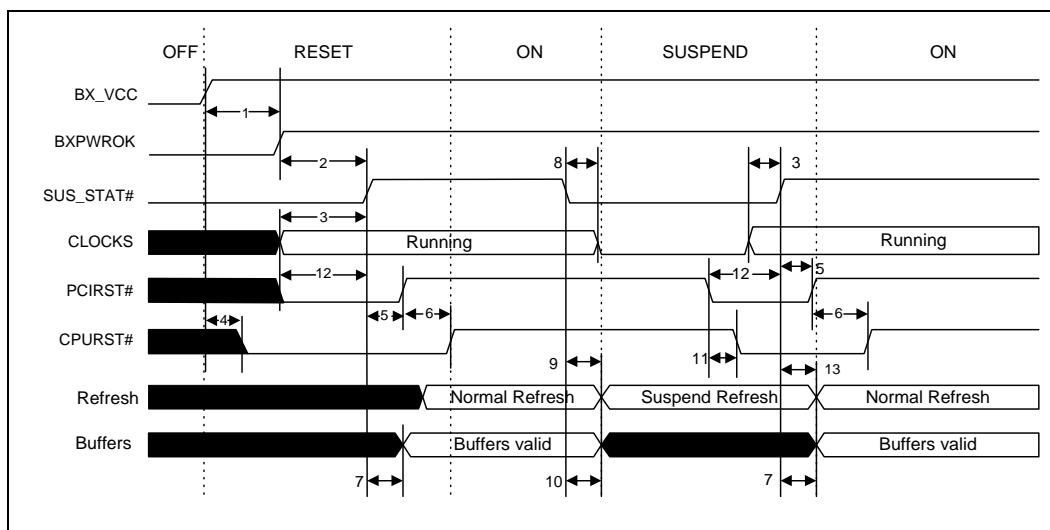

7.2.2.6 Suspend/Resume with inactive PCIRST#, CPURST#

The following resume sequence is typically used when resuming from POS. It includes the following components:

- Since PCIRST# signal is inactive, per resume the 82443BX does not drive CPURST# to the processor, since CrstEn is '0'.
- Based on the assertion of SUS_STAT#, the 82443BX isolates its I/O buffer within 32 μ s.
- Based on the deassertion of SUS_STAT#, the 82443BX enables its I/O buffer to normal operation within 32 μ s.
- The 82443BX switches from suspend refresh to normal DRAM operation mode.
- The processor starts execution from the instruction just prior to the stop grant request being recognized. The 82443BX switches to normal DRAM operation before the deassertion of STPCLK#.
- The 82443BX state is not reset.

Figure 38. Suspend/Resume with CPURST, PCIRST# Inactive

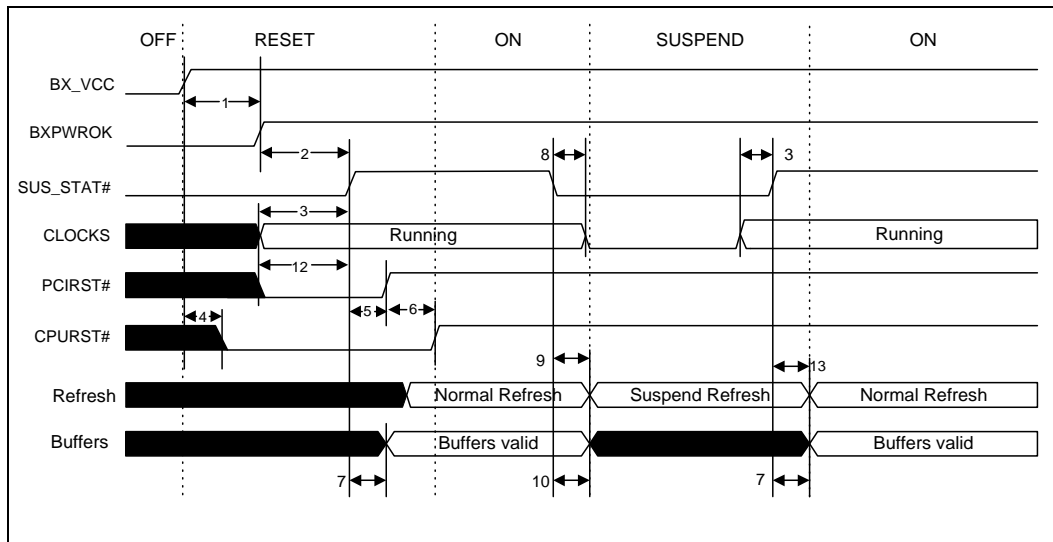

7.2.2.7 Suspend/Resume with CPURST Active, PCIRST# Inactive

The following resume sequence is typically used when resuming from POS. It includes the following components:

- The PCIRST# signal is inactive, upon resume the 82443BX drives CPURST# to the processor since CrstEn is '1'. CPURST# is active for 1 ms.
- Based on the assertion of SUS_STAT#, the 82443BX isolates its I/O buffer within 32 μ s.
- Based on the deassertion of SUS_STAT#, the 82443BX enables its I/O buffer to normal operation within 32 μ s.
- The 82443BX automatically switches from suspend refresh to normal DRAM operation mode when SUS_STAT# deassertion is detected.
- The 82443BX state is not reset.

Figure 39. Suspend/Resume with Inactive PCIRST and Active CPURST#

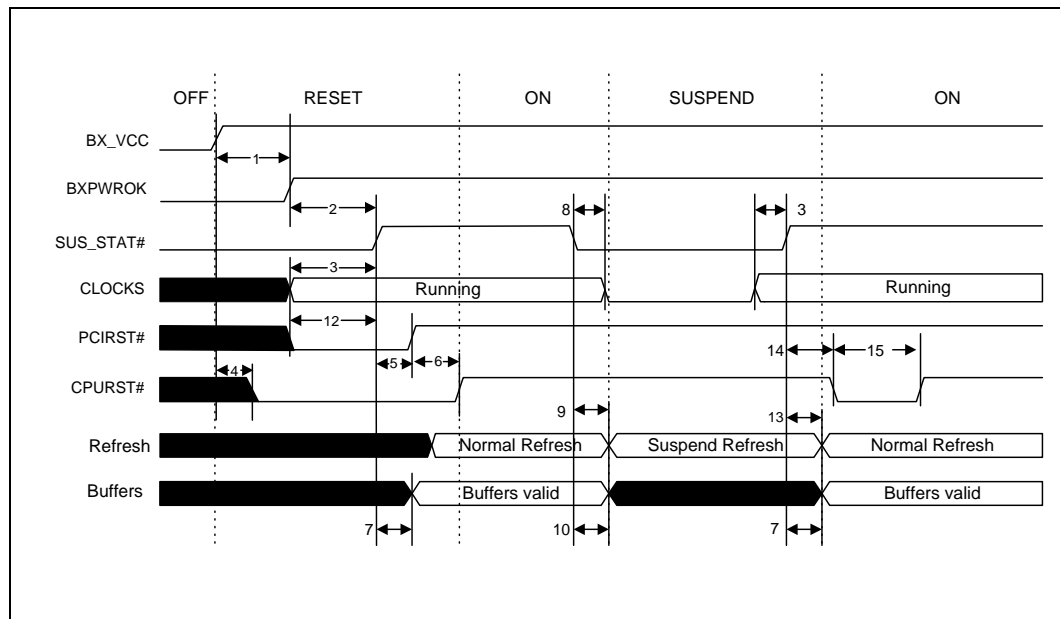

7.2.2.8 Suspend/Resume from STD

The following resume sequence is typically used when resuming from STD. It includes the following components:

- When BXPWROK is sampled low '0', the 82443BX undergoes a complete reset and asserts CPURST#.
- Based on the deassertion of SUS_STAT#, the 82443BX enables its buffer to normal operation within less than 32 μ s. Clock inputs and PCIRST# are never gated by the 82443BX and thus affect it before the deassertion of SUS_STAT#.
- Software must release the memory controller from its suspend refresh state to its normal refresh state, and enable refresh with the appropriate refresh rate.

Figure 40. Suspend/Resume from STD

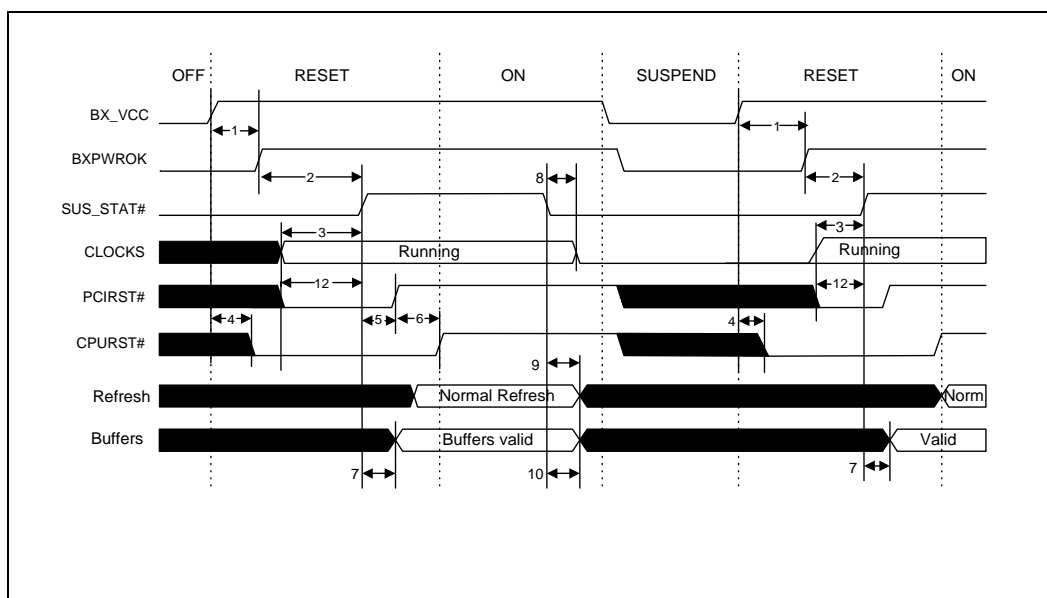

7.3 EMC-2 Power Sequencing

7.3.1 Voltage Regulator Control

The EMC-2 VR_ON pin on the EMC-2 module connector allows a digital signal (3.3 V, 5 V safe) to control the voltage regulator. The system manufacturer can use this signal to turn the Pentium II processor module voltage regulator on or off. VR_ON should be controlled as a function of the same digital control signal (SUSB#) used to control the system's switched 5-V /3.3-V power planes. The PIIX4E defines Suspend to RAM (STR) as the power-management state in which power is physically removed from most of the system components except DRAM. In this state, the SUSB# pin on the PIIX4E controls these power planes.

Caution: VR_ON should switch high only when the following conditions are met: $V_5(s) \geq 4.5\text{-V}$, and $V_{DC} \geq 4.75\text{-V}$. Turning on VR_ON prior to meeting these conditions will severely damage the module.

7.3.2 Voltage Signal Definition and Sequencing

Table 50. Voltage Signal Definitions and Sequences

Signal	Source	Definitions and Sequences
V_DC	System Electronics	DC voltage driven from the power supply and is required to be between 5-V and 21-V DC. V_DC powers the processor module's DC-to-DC converter for processor core and I/O voltages. The processor module cannot be inserted or removed while V_DC is powered on.
V_3	System Electronics	V_3 is supplied by the system electronics for the 82443BX.
V_5	System Electronics	V_5 is supplied by the system electronics for the 82443BX's 5-V reference voltage and processor module's voltage regulator.
V_3S	System Electronics	V_3S is supplied by the system electronics for the L2 cache devices. Each must be powered off during system STR and STD states.
VR_ON	System Electronics	VR_ON enables the processor module's voltage regulator circuit. When driven active high (3.3-V) the voltage regulator circuit on the processor module is activated. The signal driving VR_ON should be a digital signal with a rise/fall time of less than or equal to 1 μs .
V_CORE (also used as host bus GTL+ termination voltage VTT)	Processor module only; not on module interface.	A result of VR_ON being asserted, V_CORE is an output of the DC-DC regulator on the processor module and is driven to the core voltage of the processor. It is also used as the host bus GTL+ termination voltage (VTT).
V_BSB_IO	Processor module only; not on module interface.	V_BSB_IO is 1.8-V. The system electronics uses this voltage to power the L2 cache-to-processor interface circuitry.
VR_PWRGD	Processor module	Upon sampling the voltage level of V_CORE for the processors, minus tolerances for ripple, VR_PWRGD is driven active high (3.3 V) for the system electronics to sample prior to providing PWROK to the PIIX4. If VR_PWRGD is not sampled active within 1 second of the assertion of VR_ON the system electronics should de-assert VR_ON.
V_CPUPU	Processor module	V_CPUPU is 2.5-V. The system electronics uses this voltage to power the PIIX4E-to-processor interface circuitry
V_CLK	Processor module	V_CLK is 2.5-V. The system electronics uses this voltage to power the HCLK_(0:1) drivers for the processor clock.

Figure 41 details the sequencing of signals and voltage planes required for normal operation of the processor module.

The processor module provides the VR_PWRGD signal, which indicates that the voltage regulator power is operating at a stable voltage level. The system manufacturer should use this signal on the system electronics to control power inputs and to gate PWROK to the PIIX4E.

Figure 41. Power On Sequence

