

# OKI Semiconductor

This version: Jan. 1998  
Previous version: Mar. 1996

## MSM6502B/6512

### Low-power and Built-in LCD Driver 4-Bit Microcontroller

#### GENERAL DESCRIPTION

The MSM6502B/6512 is a low-power, 4-bit microcontroller implemented in complementary metal-oxide semiconductor technology.

The device is ideally suited to battery-powered systems such as watches and game machines because it can directly drive LCDs with up to 108 picture elements.

#### FEATURES

- ROM : 2000 words × 8 bits
  - RAM : 128 words × 4 bits
  - Number of instructions : 68
  - Clock oscillation : Crystal 32.768 kHz
  - Cycle time : 91.5 μs
  - Timer interrupt : Dual (16,128 Hz)
  - I/O port
    - Input-output port : 2 ports × 4 bits
    - Input port : 1 port × 4 bits
  - LCD drive : 108 (4 × 27) picture elements
  - Buzzer : 2000/1000/512 Hz/Soft
  - Interrupt : Three sources (external; two timer sources)
  - Stack : Nesting RAM  
Stack pointer = 7 bits
  - Power down : Halt mode available
  - Operating power supply voltage : 2.4 V to 3.6 V
  - Package options:
    - 56-pin plastic QFP (QFP56-P-910-0.65-K) : (Product name : MSM6502B-xxxGS-K,  
MSM6512-xxxGS-K)
    - 56-pin plastic QFP (QFP56-P-910-0.65-2K) : (Product name : MSM6502B-xxxGS-2K,  
MSM6512-xxxGS-2K)
- xxx indicates the code number.

**BLOCK DIAGRAM**

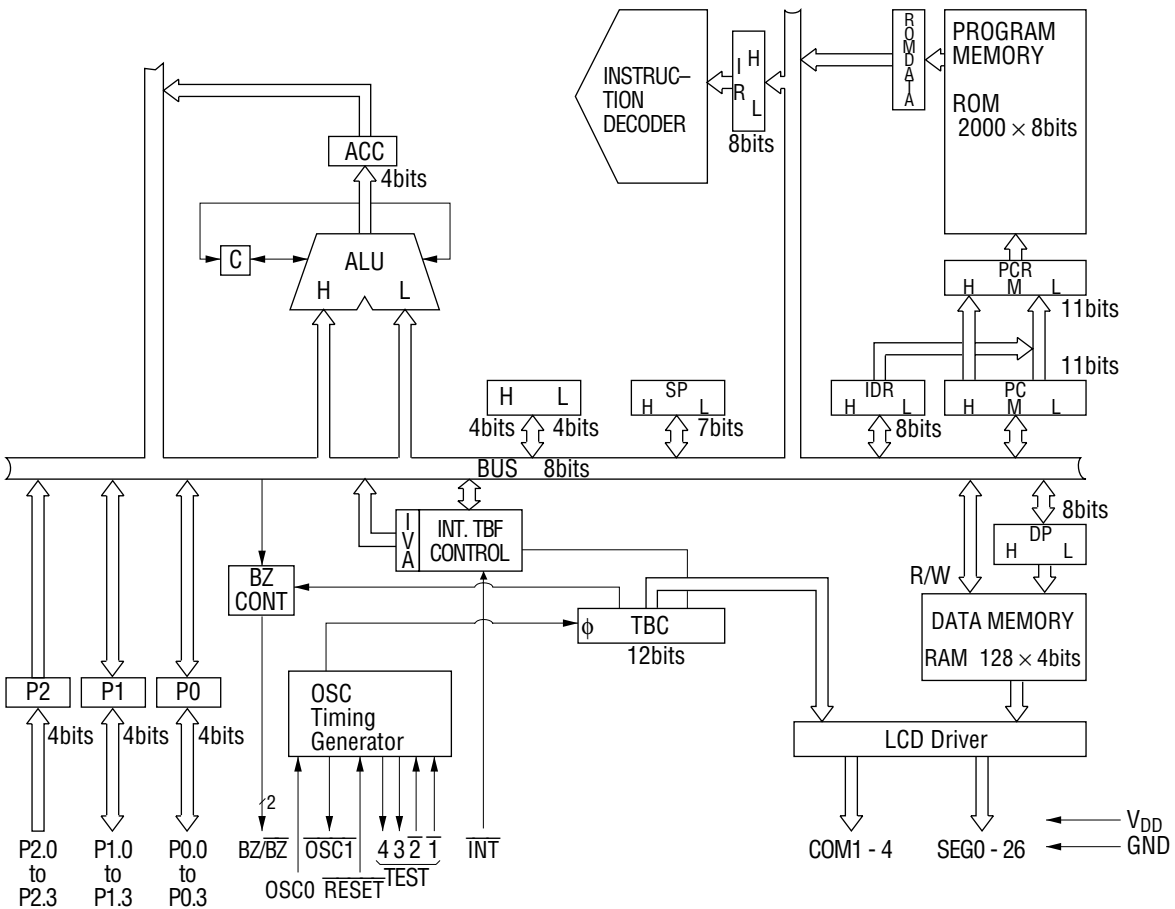

**PIN CONFIGURATION (TOP VIEW)**

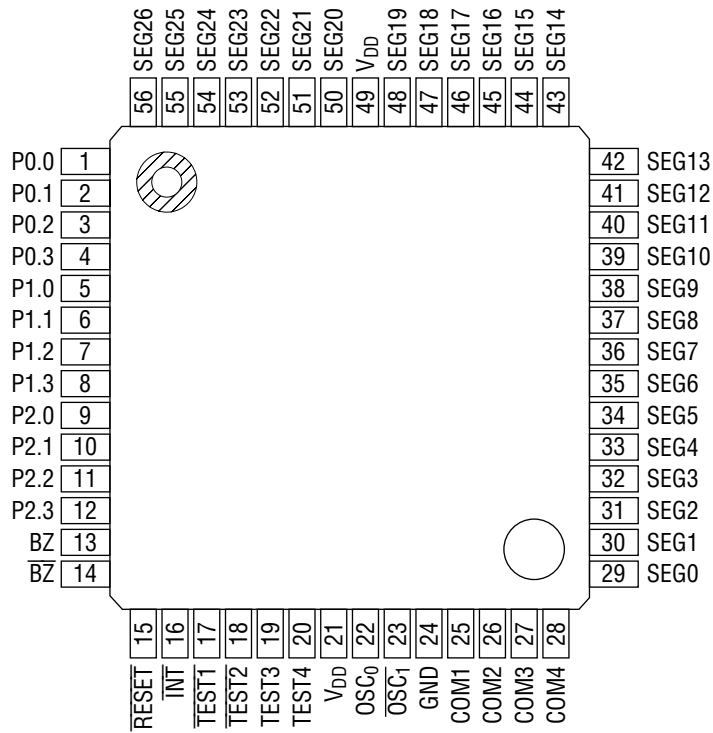

**56-Pin Plastic QFP**

**PIN DESCRIPTIONS**

Pin	Symbol	Description																
24	GND	Ground pin																
21, 49	V <sub>DD</sub>	Power supply pins																
22	OSC <sub>0</sub>	Crystal OSC input, internal clock input																
23	$\overline{OSC}_1$	Crystal OSC input, internal clock output																
1 to 4 5 to 8	P0.0 to P0.3 P1.0 to P1.3	<p>Pseudo-bidirectional ports for 4-bit parallel I/O. To input data from these ports, it is necessary to write "1" beforehand.</p> <p>The port to be selected is specified by the L register. The register contents and the corresponding specified ports are listed below.</p> <table border="1" style="margin-left: auto; margin-right: auto;"> <thead> <tr> <th>Content of L Register</th> <th>Port Specified</th> </tr> </thead> <tbody> <tr> <td>0, 8</td> <td>P0</td> </tr> <tr> <td>1, 9</td> <td>P1</td> </tr> <tr> <td>2, 0AH</td> <td>P2</td> </tr> <tr> <td>3, 0BH</td> <td>P3</td> </tr> <tr> <td>4, 0CH</td> <td>P4</td> </tr> <tr> <td>5, 0DH</td> <td>P5</td> </tr> <tr> <td>6, 7, 0EH, 0FH</td> <td>No designation</td> </tr> </tbody> </table> <p>Note: P3, P4, and P5 are internal ports.</p>	Content of L Register	Port Specified	0, 8	P0	1, 9	P1	2, 0AH	P2	3, 0BH	P3	4, 0CH	P4	5, 0DH	P5	6, 7, 0EH, 0FH	No designation
Content of L Register	Port Specified																	
0, 8	P0																	
1, 9	P1																	
2, 0AH	P2																	
3, 0BH	P3																	
4, 0CH	P4																	
5, 0DH	P5																	
6, 7, 0EH, 0FH	No designation																	
9 to 12	P2.0 to P2.3	Input port for 4-bit parallel input with no latching function.																
16	$\overline{INT}$	Input pin to request an interrupt from the external circuit. The input flag is set at the falling edge of the input signal.																
15	$\overline{RESET}$	<p>The reset mode starts after "0" is input to the <math>\overline{RESET}</math> pin for more than 2 machine cycles.</p> <p>The reset signal has priority over all of other signals and performs the following operations automatically:</p> <ol style="list-style-type: none"> <li>(1) Resets all bits of the PC (program counter) to "0".</li> <li>(2) Sets all bits of the parallel I/O ports (P0.0 to P1.3) to "1".</li> <li>(3) Resets the internal register (H, L, ACC, C, P3, P4, P5).</li> <li>(4) Resets the skip flag.</li> <li>(5) Resets all bits of the time base counter (TBC).</li> <li>(6) Resets the interrupt request flag (IRQF).</li> <li>(7) Resets the interrupt enable flag (EIF).</li> <li>(8) Resets the master interrupt enable flag (MEIF).</li> <li>(9) Sets all bits of the stack pointer (SP) to "1".</li> <li>(10) Initializes the segment and common outputs.</li> <li>(11) Sets all bits of the index register (IDR) to "1".</li> </ol> <p>Since the <math>\overline{RESET}</math> pin is pulled up to V<sub>DD</sub> by an internal resistor (800 kΩ), it is possible to achieve power ON reset by connecting it with an external capacitor.</p>																

**PIN DESCRIPTIONS (Continued)**

<b>Pin</b>	<b>Symbol</b>	<b>Description</b>
29 to 48 50 to 56 25 to 28	LCD Drive Pins SEG 0 to 26 COM 1 to 4	A special AC waveform designed to comply with liquid-crystal properties is required for liquid-crystal-drive purposes. The MSM6502B/6512 is equipped with a 1/4 duty, 1/3 bias liquid-crystal-drive circuit with four common output ports and 27 segments, to enable displays of up to 108 picture elements. On/off selection of picture elements involves writing "0" or "1" to the corresponding bits in the RAM 00H to 1AH display area, and subsequent automatic hardware controlled display. The frame frequency is 64 Hz.
13,14	BZ/ $\overline{\text{BZ}}$	BZ and $\overline{\text{BZ}}$ are used in the generation of alarms and other sounds. The selectable frequencies include three hardware frequencies (TBC output) of 512, 1024, and 2048 Hz, and a software type based on P5.0 data. These frequencies are selected at P3. When one of the hardware frequencies is selected by P3, output of that frequency is continuous. But selection of the software type results in output of the P5.0 contents to generate a melody by program.

**ABSOLUTE MAXIMUM RATINGS**

Parameter	Symbol	Condition	Rating	Unit
Power Supply Voltage	$V_{DD}$	$T_a=25^{\circ}\text{C}$	-0.3 to +7	V
Input Voltage	$V_I$		-0.3 to $V_{DD}$	V
Output Voltage	$V_O$		-0.3 to $V_{DD}$	V
Power Dissipation	$P_D$	$T_a=25^{\circ}\text{C}$ per package	200	mW
Storage Temperature	$T_{STG}$	—	-55 to +150	$^{\circ}\text{C}$

**RECOMMENDED OPERATING CONDITIONS**

Parameter	Symbol	Condition	Range	Unit
Power Supply Voltage	$V_{DD}$	$f_{OSC} \leq 32.768$ kHz	2.4 to 3.6	V
Operating Temperature	$T_{op}$	—	-20 to +70	$^{\circ}\text{C}$

**ELECTRICAL CHARACTERISTICS**

**DC Characteristics**

(V<sub>DD</sub>=3 V, T<sub>a</sub>=-20 to +70°C)

Parameter	Symbol	Condition	Min.	Typ.	Max.	Unit	
"H" Input Voltage	V <sub>IH</sub>	—	2.6	—	—	V	
"L" Input Voltage	V <sub>IL</sub>	—	—	—	0.4	V	
"H" Output Voltage (*1)	V <sub>OH</sub>	I <sub>O</sub> =-1.0 mA	2.0	—	—	V	
"L" Output Voltage (*2)	V <sub>OL</sub>	I <sub>O</sub> =1.0 mA	—	—	1.0	V	
LCD Drive Output Voltage (*3)	V <sub>3</sub>	MSM6502B	I <sub>O</sub> =-5 μA	2.8	—	3.0	V
		MSM6512	I <sub>O</sub> =-2 μA				
	V <sub>2</sub>	MSM6502B	I <sub>O</sub> =±2 μA	1.8	—	2.2	V
		MSM6512	I <sub>O</sub> =±0.5 μA				
	V <sub>1</sub>	MSM6502B	I <sub>O</sub> =±2 μA	0.8	—	1.2	V
		MSM6512	I <sub>O</sub> =±0.5 μA				
V <sub>0</sub>	MSM6502B	I <sub>O</sub> =5 μA	0.0	—	0.2	V	
	MSM6512	I <sub>O</sub> =2 μA					
OSC <sub>0</sub> Input Current	I <sub>IH</sub> /I <sub>IL</sub>	V <sub>I</sub> =V <sub>DD</sub> /V <sub>I</sub> =0 V	—	—	2/-2	μA	
Input Current (*4)	I <sub>IH</sub> /I <sub>IL</sub>	V <sub>I</sub> =V <sub>DD</sub> /V <sub>I</sub> =0 V	—	—	1/-10	μA	
Input Current (*5)	I <sub>IH</sub> /I <sub>IL</sub>	V <sub>I</sub> =V <sub>DD</sub> /V <sub>I</sub> =0 V	—	—	1000/-1	μA	
Input Current (*6)	I <sub>IH</sub> /I <sub>IL</sub>	V <sub>I</sub> =V <sub>DD</sub> /V <sub>I</sub> =0 V	—	—	1/-10	μA	
P0, P1 "H" Output Current	I <sub>OH</sub>	V <sub>O</sub> =0 V	—	—	-50	μA	
Current Consumption	I <sub>DD</sub>	MSM6502B	f <sub>osc</sub> =32.768 kHz at no load	—	45	70	μA
		MSM6512		—	30	55	
	I <sub>DDHLT</sub>	MSM6502B	f <sub>osc</sub> =32.768 kHz at HLT execution	—	30	40	μA
		MSM6512		—	12	25	
	I <sub>DDS</sub>	MSM6502B	Static	—	15	25	μA
		MSM6512		—	5	15	
Oscillation Start Time	T <sub>OSC</sub>	—	—	—	10	sec	

\*1 Applied to BZ,  $\overline{BZ}$

\*2 Applied to BZ, BZ, P0, P1

\*3 Applied to COM1-4, SEG0-26

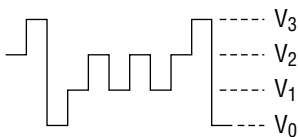

\*4 Applied to  $\overline{RESET}$ ,  $\overline{INT}$

\*5 Applied to P2 (When input is disabled)

\*6 Applied to P2 (When input is enabled)

Switching Characteristics

(V<sub>DD</sub>=3 V, T<sub>a</sub>=-20 to +70°C)

Parameter	Symbol	Condition	Min.	Typ.	Max.	Unit
Clock (OSC <sub>0</sub> ) Pulse Width	t <sub>φW</sub>	—	15	—	—	μs
Cycle Time	t <sub>CY</sub>	—	(*1)	—	—	μs
P0 P1 Data Valid Time	t <sub>DV</sub>	—	(*2)	—	—	μs
P0 P1 Data Invalid Time	t <sub>DIV</sub>	—	—	—	(*3)	μs
P0 P1 Data Delay Time	t <sub>DDS</sub>	C <sub>L</sub> =50 pF	—	—	(*4)	μs

\*1 t<sub>CY</sub>=3 × 1/f<sub>OSC</sub>

\*2 t<sub>DV</sub>=1/2 × 1/f<sub>OSC</sub>

\*3 t<sub>DIV</sub>=1 × 1/f<sub>OSC</sub> + 10 μs

\*4 t<sub>DDS</sub>=5/2 × 1/f<sub>OSC</sub> + 15 μs

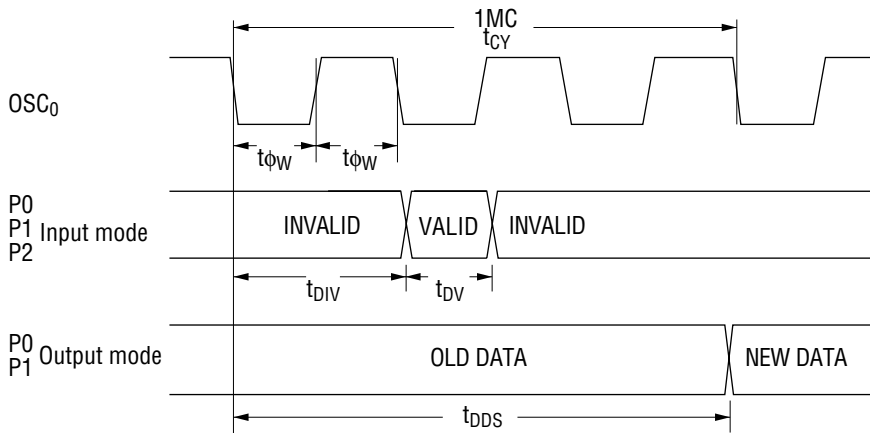



**Operating Characteristics (MSM6502B)**

High-level Output Current ( $I_{OH}$ ) - Output Voltage ( $V_{OH}$ )

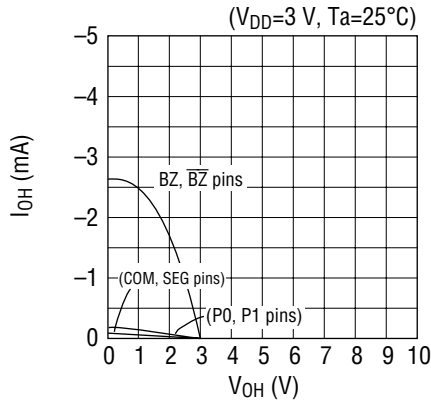

Low-level Output Current ( $I_{OL}$ ) - Output Voltage ( $V_{OL}$ )

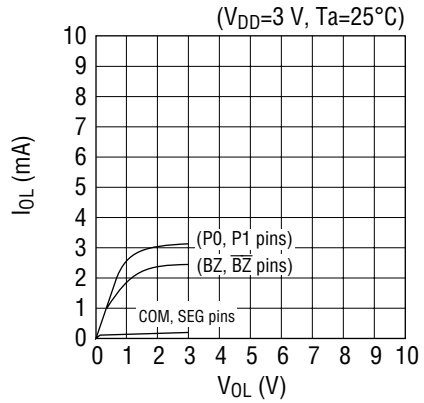

Middle-level Output Current ( $I_1, I_2$ ) - Output Voltage ( $V_1, V_2$ )

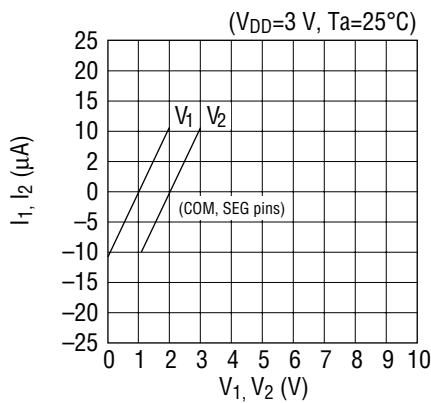

Current Consumption ( $I_{DD}$ ) - Power Supply Voltage ( $V_{DD}$ )

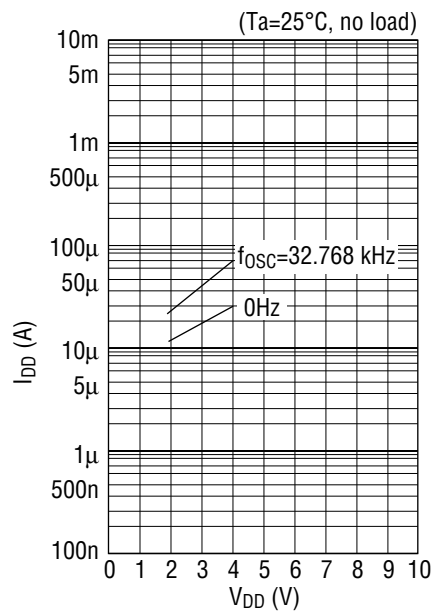

**Operating Characteristics (MSM6512)**

High-level Output Current ( $I_{OH}$ ) - Output Voltage ( $V_{OH}$ )

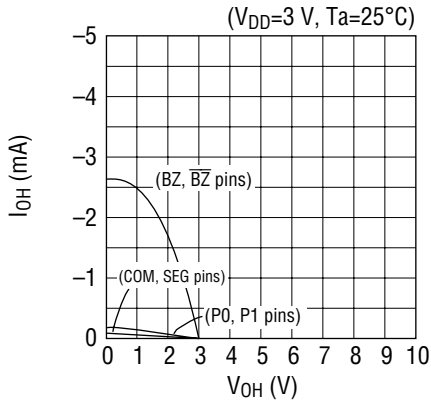

Low-level Output Current ( $I_{OL}$ ) - Output Voltage ( $V_{OL}$ )

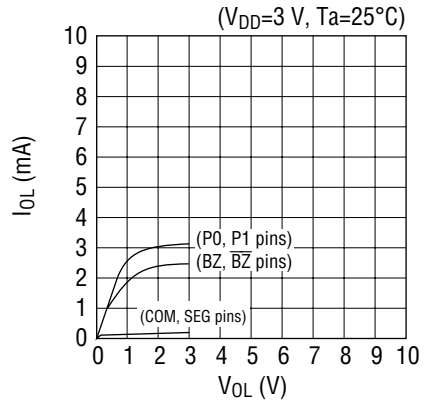

Middle-level Output Current ( $I_1, I_2$ ) - Output Voltage ( $V_1, V_2$ )

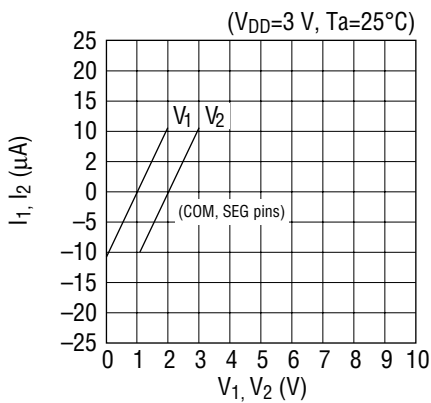

Current Consumption ( $I_{DD}$ ) - Power Supply Voltage ( $V_{DD}$ )

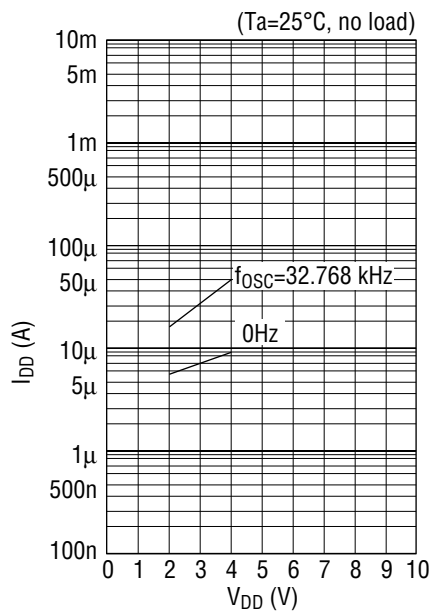

**PACKAGE DIMENSIONS**

(Unit : mm)

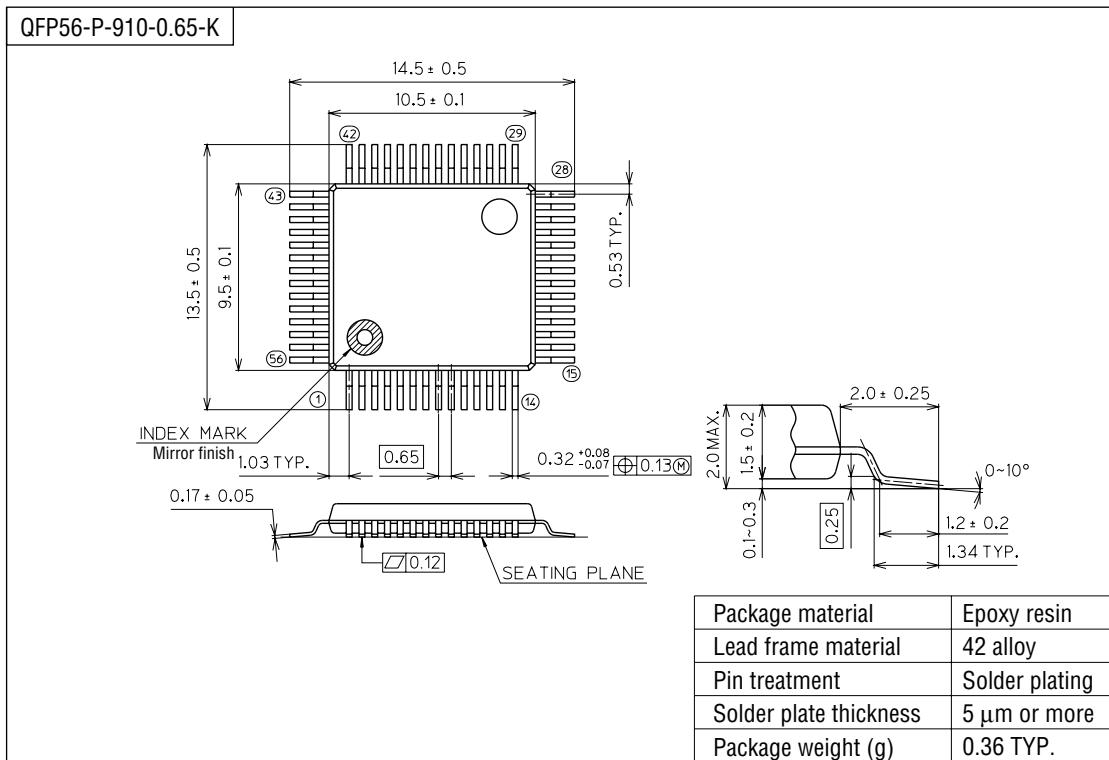

**Notes for Mounting the Surface Mount Type Package**

The SOP, QFP, TSOP, SOJ, QFJ (PLCC), SHP and BGA are surface mount type packages, which are very susceptible to heat in reflow mounting and humidity absorbed in storage. Therefore, before you perform reflow mounting, contact Oki's responsible sales person for the product name, package name, pin number, package code and desired mounting conditions (reflow method, temperature and times).

(Unit : mm)

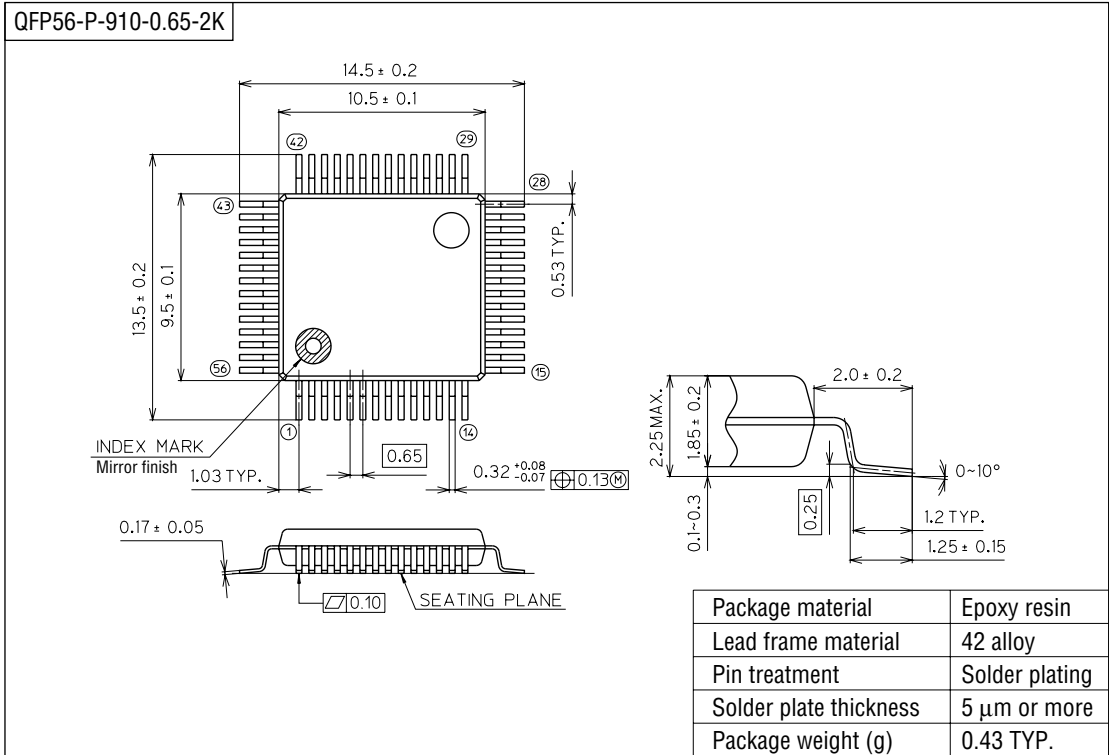

### Notes for Mounting the Surface Mount Type Package

The SOP, QFP, TSOP, SOJ, QFJ (PLCC), SHP and BGA are surface mount type packages, which are very susceptible to heat in reflow mounting and humidity absorbed in storage. Therefore, before you perform reflow mounting, contact Oki's responsible sales person for the product name, package name, pin number, package code and desired mounting conditions (reflow method, temperature and times).