

80C186EA/80C188EA
Microprocessor
User's Manual

intel[®]

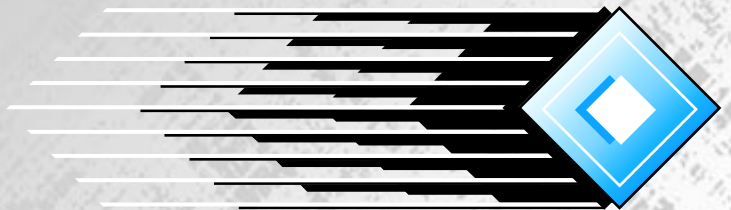



**80C186EA/80C188EA
Microprocessor
User's Manual**

1995



Information in this document is provided solely to enable use of Intel products. Intel assumes no liability whatsoever, including infringement of any patent or copyright, for sale and use of Intel products except as provided in Intel's Terms and Conditions of Sale for such products.

Intel Corporation makes no warranty for the use of its products and assumes no responsibility for any errors which may appear in this document nor does it make a commitment to update the information contained herein.

Intel retains the right to make changes to these specifications at any time, without notice.

Contact your local Intel sales office or your distributor to obtain the latest specifications before placing your product order.

MDS is an ordering code only and is not used as a product name or trademark of Intel Corporation.

Intel Corporation and Intel's FASTPATH are not affiliated with Kinetics, a division of Excelan, Inc. or its FASTPATH trademark or products.

*Other brands and names are the property of their respective owners.

Additional copies of this document or other Intel literature may be obtained from:

Intel Corporation
Literature Sales
P.O. Box 7641
Mt. Prospect, IL 60056-7641
or call 1-800-879-4683

CONTENTS

CHAPTER 1

INTRODUCTION

1.1	HOW TO USE THIS MANUAL.....	1-2
1.2	RELATED DOCUMENTS.....	1-3
1.3	ELECTRONIC SUPPORT SYSTEMS.....	1-4
1.3.1	FaxBack Service.....	1-4
1.3.2	Bulletin Board System (BBS).....	1-5
1.3.2.1	How to Find ApBUILDER Software and Hypertext Documents on the BBS.....	1-5
1.3.3	CompuServe Forums.....	1-6
1.3.4	World Wide Web.....	1-6
1.4	TECHNICAL SUPPORT.....	1-6
1.5	PRODUCT LITERATURE.....	1-6

CHAPTER 2

OVERVIEW OF THE 80C186 FAMILY ARCHITECTURE

2.1	ARCHITECTURAL OVERVIEW.....	2-1
2.1.1	Execution Unit.....	2-2
2.1.2	Bus Interface Unit.....	2-3
2.1.3	General Registers.....	2-4
2.1.4	Segment Registers.....	2-5
2.1.5	Instruction Pointer.....	2-6
2.1.6	Flags.....	2-7
2.1.7	Memory Segmentation.....	2-8
2.1.8	Logical Addresses.....	2-10
2.1.9	Dynamically Relocatable Code.....	2-13
2.1.10	Stack Implementation.....	2-15
2.1.11	Reserved Memory and I/O Space.....	2-15
2.2	SOFTWARE OVERVIEW.....	2-17
2.2.1	Instruction Set.....	2-17
2.2.1.1	Data Transfer Instructions.....	2-18
2.2.1.2	Arithmetic Instructions.....	2-19
2.2.1.3	Bit Manipulation Instructions.....	2-21
2.2.1.4	String Instructions.....	2-22
2.2.1.5	Program Transfer Instructions.....	2-23
2.2.1.6	Processor Control Instructions.....	2-27
2.2.2	Addressing Modes.....	2-27
2.2.2.1	Register and Immediate Operand Addressing Modes.....	2-27
2.2.2.2	Memory Addressing Modes.....	2-28
2.2.2.3	I/O Port Addressing.....	2-36
2.2.2.4	Data Types Used in the 80C186 Modular Core Family.....	2-37

2.3 INTERRUPTS AND EXCEPTION HANDLING 2-39

2.3.1 Interrupt/Exception Processing2-39

2.3.1.1 Non-Maskable Interrupts2-42

2.3.1.2 Maskable Interrupts2-43

2.3.1.3 Exceptions2-43

2.3.2 Software Interrupts2-45

2.3.3 Interrupt Latency2-45

2.3.4 Interrupt Response Time2-46

2.3.5 Interrupt and Exception Priority2-46

CHAPTER 3
BUS INTERFACE UNIT

3.1 MULTIPLEXED ADDRESS AND DATA BUS 3-1

3.2 ADDRESS AND DATA BUS CONCEPTS 3-1

3.2.1 16-Bit Data Bus3-1

3.2.2 8-Bit Data Bus3-5

3.3 MEMORY AND I/O INTERFACES 3-6

3.3.1 16-Bit Bus Memory and I/O Requirements3-7

3.3.2 8-Bit Bus Memory and I/O Requirements3-7

3.4 BUS CYCLE OPERATION 3-7

3.4.1 Address/Status Phase3-10

3.4.2 Data Phase3-13

3.4.3 Wait States3-13

3.4.4 Idle States3-18

3.5 BUS CYCLES 3-20

3.5.1 Read Bus Cycles3-20

3.5.1.1 Refresh Bus Cycles3-22

3.5.2 Write Bus Cycles3-22

3.5.3 Interrupt Acknowledge Bus Cycle3-25

3.5.3.1 System Design Considerations3-27

3.5.4 HALT Bus Cycle3-28

3.5.5 Temporarily Exiting the HALT Bus State3-31

3.5.6 Exiting HALT3-33

3.6 SYSTEM DESIGN ALTERNATIVES 3-35

3.6.1 Buffering the Data Bus3-36

3.6.2 Synchronizing Software and Hardware Events3-38

3.6.3 Using a Locked Bus3-39

3.6.4 Using the Queue Status Signals3-40

3.7 MULTI-MASTER BUS SYSTEM DESIGNS..... 3-41

3.7.1 Entering Bus HOLD3-41

3.7.1.1 HOLD Bus Latency3-42

3.7.1.2 Refresh Operation During a Bus HOLD3-43

3.7.2 Exiting HOLD3-45

3.8 BUS CYCLE PRIORITIES 3-46

CHAPTER 4

PERIPHERAL CONTROL BLOCK

4.1	PERIPHERAL CONTROL REGISTERS.....	4-1
4.2	PCB RELOCATION REGISTER.....	4-1
4.3	RESERVED LOCATIONS	4-4
4.4	ACCESSING THE PERIPHERAL CONTROL BLOCK.....	4-4
4.4.1	Bus Cycles	4-4
4.4.2	READY Signals and Wait States	4-4
4.4.3	F-Bus Operation	4-5
4.4.3.1	Writing the PCB Relocation Register	4-6
4.4.3.2	Accessing the Peripheral Control Registers	4-6
4.4.3.3	Accessing Reserved Locations	4-6
4.5	SETTING THE PCB BASE LOCATION.....	4-6
4.5.1	Considerations for the 80C187 Math Coprocessor Interface	4-7

CHAPTER 5

CLOCK GENERATION AND POWER MANAGEMENT

5.1	CLOCK GENERATION.....	5-1
5.1.1	Crystal Oscillator	5-1
5.1.1.1	Oscillator Operation	5-2
5.1.1.2	Selecting Crystals	5-5
5.1.2	Using an External Oscillator	5-6
5.1.3	Output from the Clock Generator	5-6
5.1.4	Reset and Clock Synchronization	5-6
5.2	POWER MANAGEMENT.....	5-10
5.2.1	Idle Mode	5-11
5.2.1.1	Entering Idle Mode	5-11
5.2.1.2	Bus Operation During Idle Mode	5-13
5.2.1.3	Leaving Idle Mode	5-14
5.2.1.4	Example Idle Mode Initialization Code	5-15
5.2.2	Powerdown Mode	5-16
5.2.2.1	Entering Powerdown Mode	5-17
5.2.2.2	Leaving Powerdown Mode	5-18
5.2.3	Power-Save Mode	5-19
5.2.3.1	Entering Power-Save Mode	5-19
5.2.3.2	Leaving Power-Save Mode	5-21
5.2.3.3	Example Power-Save Initialization Code	5-21
5.2.4	Implementing a Power Management Scheme	5-23

CHAPTER 6

CHIP-SELECT UNIT

6.1	COMMON METHODS FOR GENERATING CHIP-SELECTS.....	6-1
6.2	CHIP-SELECT UNIT FEATURES AND BENEFITS	6-1
6.3	CHIP-SELECT UNIT FUNCTIONAL OVERVIEW	6-2
6.4	PROGRAMMING	6-6
6.4.1	Initialization Sequence	6-6
6.4.2	Programming the Active Ranges	6-12
6.4.2.1	UCS Active Range	6-12
6.4.2.2	LCS Active Range	6-13
6.4.2.3	MCS Active Range	6-13
6.4.2.4	PCS Active Range	6-15
6.4.3	Bus Wait State and Ready Control	6-15
6.4.4	Overlapping Chip-Selects	6-16
6.4.5	Memory or I/O Bus Cycle Decoding	6-17
6.4.6	Programming Considerations	6-17
6.5	CHIP-SELECTS AND BUS HOLD.....	6-18
6.6	EXAMPLES	6-18
6.6.1	Example 1: Typical System Configuration	6-18

CHAPTER 7

REFRESH CONTROL UNIT

7.1	THE ROLE OF THE REFRESH CONTROL UNIT.....	7-2
7.2	REFRESH CONTROL UNIT CAPABILITIES.....	7-2
7.3	REFRESH CONTROL UNIT OPERATION.....	7-2
7.4	REFRESH ADDRESSES.....	7-4
7.5	REFRESH BUS CYCLES.....	7-5
7.6	GUIDELINES FOR DESIGNING DRAM CONTROLLERS.....	7-5
7.7	PROGRAMMING THE REFRESH CONTROL UNIT.....	7-7
7.7.1	Calculating the Refresh Interval	7-7
7.7.2	Refresh Control Unit Registers	7-7
7.7.2.1	Refresh Base Address Register	7-8
7.7.2.2	Refresh Clock Interval Register	7-8
7.7.2.3	Refresh Control Register	7-9
7.7.3	Programming Example	7-10
7.8	REFRESH OPERATION AND BUS HOLD.....	7-12

CHAPTER 8
INTERRUPT CONTROL UNIT

8.1	FUNCTIONAL OVERVIEW.....	8-1
8.2	MASTER MODE	8-2
8.2.1	Generic Functions in Master Mode	8-2
8.2.1.1	Interrupt Masking	8-3
8.2.1.2	Interrupt Priority	8-3
8.2.1.3	Interrupt Nesting	8-4
8.3	FUNCTIONAL OPERATION IN MASTER MODE	8-5
8.3.1	Typical Interrupt Sequence	8-5
8.3.2	Priority Resolution	8-5
8.3.2.1	Priority Resolution Example	8-6
8.3.2.2	Interrupts That Share a Single Source	8-7
8.3.3	Cascading with External 8259As	8-7
8.3.3.1	Special Fully Nested Mode	8-8
8.3.4	Interrupt Acknowledge Sequence	8-9
8.3.5	Polling	8-9
8.3.6	Edge and Level Triggering	8-10
8.3.7	Additional Latency and Response Time	8-10
8.4	PROGRAMMING THE INTERRUPT CONTROL UNIT	8-11
8.4.1	Interrupt Control Registers	8-12
8.4.2	Interrupt Request Register	8-16
8.4.3	Interrupt Mask Register	8-16
8.4.4	Priority Mask Register	8-17
8.4.5	In-Service Register	8-18
8.4.6	Poll and Poll Status Registers	8-19
8.4.7	End-of-Interrupt (EOI) Register	8-21
8.4.8	Interrupt Status Register	8-22
8.5	SLAVE MODE	8-23
8.5.1	Slave Mode Programming	8-25
8.5.1.1	Interrupt Vector Register	8-26
8.5.1.2	End-Of-Interrupt Register	8-27
8.5.1.3	Other Registers	8-28
8.5.2	Interrupt Vectoring in Slave Mode	8-29
8.5.3	Initializing the Interrupt Control Unit for Master Mode	8-30

CHAPTER 9
TIMER/COUNTER UNIT

9.1	FUNCTIONAL OVERVIEW.....	9-1
9.2	PROGRAMMING THE TIMER/COUNTER UNIT	9-6
9.2.1	Initialization Sequence	9-11
9.2.2	Clock Sources	9-12
9.2.3	Counting Modes	9-12
9.2.3.1	Retriggering	9-13

- 9.2.4 Pulsed and Variable Duty Cycle Output 9-14
- 9.2.5 Enabling/Disabling Counters 9-15
- 9.2.6 Timer Interrupts 9-16
- 9.2.7 Programming Considerations 9-16
- 9.3 TIMING 9-16
 - 9.3.1 Input Setup and Hold Timings 9-16
 - 9.3.2 Synchronization and Maximum Frequency 9-17
 - 9.3.2.1 Timer/Counter Unit Application Examples 9-17
 - 9.3.3 Real-Time Clock 9-17
 - 9.3.4 Square-Wave Generator 9-17
 - 9.3.5 Digital One-Shot 9-17

CHAPTER 10

DIRECT MEMORY ACCESS UNIT

- 10.1 FUNCTIONAL OVERVIEW..... 10-1
 - 10.1.1 The DMA Transfer 10-1
 - 10.1.1.1 DMA Transfer Directions 10-3
 - 10.1.1.2 Byte and Word Transfers 10-3
 - 10.1.2 Source and Destination Pointers 10-3
 - 10.1.3 DMA Requests 10-3
 - 10.1.4 External Requests 10-4
 - 10.1.4.1 Source Synchronization 10-5
 - 10.1.4.2 Destination Synchronization 10-5
 - 10.1.5 Internal Requests 10-6
 - 10.1.5.1 Timer 2-Initiated Transfers 10-6
 - 10.1.5.2 Unsynchronized Transfers 10-6
 - 10.1.6 DMA Transfer Counts 10-7
 - 10.1.7 Termination and Suspension of DMA Transfers 10-7
 - 10.1.7.1 Termination at Terminal Count 10-7
 - 10.1.7.2 Software Termination 10-7
 - 10.1.7.3 Suspension of DMA During NMI 10-7
 - 10.1.7.4 Software Suspension 10-7
 - 10.1.8 DMA Unit Interrupts 10-8
 - 10.1.9 DMA Cycles and the BIU 10-8
 - 10.1.10 The Two-Channel DMA Unit 10-8
 - 10.1.10.1 DMA Channel Arbitration 10-8
- 10.2 PROGRAMMING THE DMA UNIT 10-10
 - 10.2.1 DMA Channel Parameters 10-10
 - 10.2.1.1 Programming the Source and Destination Pointers 10-10
 - 10.2.1.2 Selecting Byte or Word Size Transfers 10-14
 - 10.2.1.3 Selecting the Source of DMA Requests 10-17
 - 10.2.1.4 Arming the DMA Channel 10-18
 - 10.2.1.5 Selecting Channel Synchronization 10-18
 - 10.2.1.6 Programming the Transfer Count Options 10-18
 - 10.2.1.7 Generating Interrupts on Terminal Count 10-19

- 10.2.1.8 Setting the Relative Priority of a Channel 10-19
- 10.2.2 Suspension of DMA Transfers 10-20
- 10.2.3 Initializing the DMA Unit 10-20
- 10.3 HARDWARE CONSIDERATIONS AND THE DMA UNIT 10-20
- 10.3.1 DRQ Pin Timing Requirements 10-20
- 10.3.2 DMA Latency 10-21
- 10.3.3 DMA Transfer Rates 10-21
- 10.3.4 Generating a DMA Acknowledge 10-22
- 10.4 DMA UNIT EXAMPLES 10-22

CHAPTER 11

MATH COPROCESSING

- 11.1 OVERVIEW OF MATH COPROCESSING 11-1
- 11.2 AVAILABILITY OF MATH COPROCESSING 11-1
- 11.3 THE 80C187 MATH COPROCESSOR..... 11-2
- 11.3.1 80C187 Instruction Set 11-2
- 11.3.1.1 Data Transfer Instructions 11-3
- 11.3.1.2 Arithmetic Instructions 11-3
- 11.3.1.3 Comparison Instructions 11-5
- 11.3.1.4 Transcendental Instructions 11-5
- 11.3.1.5 Constant Instructions 11-6
- 11.3.1.6 Processor Control Instructions 11-6
- 11.3.2 80C187 Data Types 11-7
- 11.4 MICROPROCESSOR AND COPROCESSOR OPERATION..... 11-7
- 11.4.1 Clocking the 80C187 11-10
- 11.4.2 Processor Bus Cycles Accessing the 80C187 11-10
- 11.4.3 System Design Tips 11-11
- 11.4.4 Exception Trapping 11-13
- 11.5 EXAMPLE MATH COPROCESSOR ROUTINES..... 11-13

CHAPTER 12

ONCE MODE

- 12.1 ENTERING/LEAVING ONCE MODE..... 12-1

APPENDIX A

80C186 INSTRUCTION SET ADDITIONS AND EXTENSIONS

- A.1 80C186 INSTRUCTION SET ADDITIONS A-1
- A.1.1 Data Transfer Instructions A-1
- A.1.2 String Instructions A-2
- A.1.3 High-Level Instructions A-2
- A.2 80C186 INSTRUCTION SET ENHANCEMENTS..... A-8
- A.2.1 Data Transfer Instructions A-8
- A.2.2 Arithmetic Instructions A-9

CONTENTS

A.2.3	Bit Manipulation Instructions	A-9
A.2.3.1	Shift Instructions	A-9
A.2.3.2	Rotate Instructions	A-10

APPENDIX B

INPUT SYNCHRONIZATION

B.1	WHY SYNCHRONIZERS ARE REQUIRED	B-1
B.2	ASYNCHRONOUS PINS	B-2

APPENDIX C

INSTRUCTION SET DESCRIPTIONS

APPENDIX D

INSTRUCTION SET OPCODES AND CLOCK CYCLES

INDEX

FIGURES

Figure	Page
2-1	Simplified Functional Block Diagram of the 80C186 Family CPU2-2
2-2	Physical Address Generation2-3
2-3	General Registers2-4
2-4	Segment Registers2-6
2-5	Processor Status Word2-9
2-6	Segment Locations in Physical Memory.....2-10
2-7	Currently Addressable Segments.....2-11
2-8	Logical and Physical Address2-12
2-9	Dynamic Code Relocation.....2-14
2-10	Stack Operation.....2-16
2-11	Flag Storage Format2-19
2-12	Memory Address Computation2-29
2-13	Direct Addressing2-30
2-14	Register Indirect Addressing2-31
2-15	Based Addressing2-31
2-16	Accessing a Structure with Based Addressing.....2-32
2-17	Indexed Addressing.....2-33
2-18	Accessing an Array with Indexed Addressing2-33
2-19	Based Index Addressing2-34
2-20	Accessing a Stacked Array with Based Index Addressing.....2-35
2-21	String Operand2-36
2-22	I/O Port Addressing2-36
2-23	80C186 Modular Core Family Supported Data Types.....2-38
2-24	Interrupt Control Unit2-39
2-25	Interrupt Vector Table.....2-40
2-26	Interrupt Sequence2-42
2-27	Interrupt Response Factors.....2-46
2-28	Simultaneous NMI and Exception2-47
2-29	Simultaneous NMI and Single Step Interrupts.....2-48
2-30	Simultaneous NMI, Single Step and Maskable Interrupt.....2-49
3-1	Physical Data Bus Models.....3-2
3-2	16-Bit Data Bus Byte Transfers.....3-3
3-3	16-Bit Data Bus Even Word Transfers3-4
3-4	16-Bit Data Bus Odd Word Transfers.....3-5
3-5	8-Bit Data Bus Word Transfers.....3-6
3-6	Typical Bus Cycle.....3-8
3-7	T-State Relation to CLKOUT3-8
3-8	BIU State Diagram3-9
3-9	T-State and Bus Phases3-10
3-10	Address/Status Phase Signal Relationships3-11
3-11	Demultiplexing Address Information.....3-12
3-12	Data Phase Signal Relationships3-14
3-13	Typical Bus Cycle with Wait States3-15
3-14	ARDY and SRDY Pin Block Diagram.....3-15

FIGURES

Figure	Page
3-15	Generating a Normally Not-Ready Bus Signal 3-16
3-16	Generating a Normally Ready Bus Signal 3-17
3-17	Normally Not-Ready System Timing 3-18
3-18	Normally Ready System Timings 3-19
3-19	Typical Read Bus Cycle 3-21
3-20	Read-Only Device Interface 3-22
3-21	Typical Write Bus Cycle 3-23
3-22	16-Bit Bus Read/Write Device Interface 3-24
3-23	Interrupt Acknowledge Bus Cycle 3-26
3-24	Typical 82C59A Interface 3-27
3-25	HALT Bus Cycle 3-30
3-26	Returning to HALT After a HOLD/HLDA Bus Exchange 3-31
3-27	Returning to HALT After a Refresh Bus Cycle 3-32
3-28	Returning to HALT After a DMA Bus Cycle 3-33
3-29	Exiting HALT (Powerdown Mode) 3-34
3-30	Exiting HALT (Active/Idle Mode) 3-35
3-31	\overline{DEN} and DT/R Timing Relationships 3-36
3-32	Buffered AD Bus System 3-37
3-33	Qualifying \overline{DEN} with Chip-Selects 3-38
3-34	Queue Status Timing 3-41
3-35	Timing Sequence Entering HOLD 3-42
3-36	Refresh Request During HOLD 3-44
3-37	Latching HLDA 3-45
3-38	Exiting HOLD 3-46
4-1	PCB Relocation Register 4-2
5-1	Clock Generator 5-1
5-2	Ideal Operation of Pierce Oscillator 5-2
5-3	Crystal Connections to Microprocessor 5-3
5-4	Equations for Crystal Calculations 5-4
5-5	Simple RC Circuit for Powerup Reset 5-7
5-6	Cold Reset Waveform 5-8
5-7	Warm Reset Waveform 5-9
5-8	Clock Synchronization at Reset 5-10
5-9	Power Control Register 5-12
5-10	Entering Idle Mode 5-13
5-11	HOLD/HLDA During Idle Mode 5-14
5-12	Entering Powerdown Mode 5-17
5-13	Powerdown Timer Circuit 5-18
5-14	Power-Save Register 5-20
5-15	Power-Save Clock Transition 5-21
6-1	Common Chip-Select Generation Methods 6-2
6-2	Chip-Select Block Diagram 6-3
6-3	Chip-Select Relative Timings 6-4
6-4	\overline{UCS} Reset Configuration 6-5

FIGURES

Figure		Page
6-5	UMCS Register Definition.....	6-7
6-6	LMCS Register Definition.....	6-8
6-7	MMCS Register Definition.....	6-9
6-8	PACS Register Definition.....	6-10
6-9	MPCS Register Definition.....	6-11
6-10	MCS3:0 Active Ranges.....	6-14
6-11	Wait State and Ready Control Functions.....	6-16
6-12	Using Chip-Selects During HOLD.....	6-18
6-13	Typical System.....	6-19
7-1	Refresh Control Unit Block Diagram.....	7-1
7-2	Refresh Control Unit Operation Flow Chart.....	7-3
7-3	Refresh Address Formation.....	7-4
7-4	Suggested DRAM Control Signal Timing Relationships.....	7-6
7-5	Formula for Calculating Refresh Interval for RFTIME Register.....	7-7
7-6	Refresh Base Address Register.....	7-8
7-7	Refresh Clock Interval Register.....	7-9
7-8	Refresh Control Register.....	7-10
7-9	Regaining Bus Control to Run a DRAM Refresh Bus Cycle.....	7-13
8-1	Interrupt Control Unit in Master Mode.....	8-2
8-2	Using External 8259A Modules in Cascade Mode.....	8-8
8-3	Interrupt Control Unit Latency and Response Time.....	8-11
8-4	Interrupt Control Register for Internal Sources.....	8-13
8-5	Interrupt Control Register for Noncascadable External Pins.....	8-14
8-6	Interrupt Control Register for Cascadable Interrupt Pins.....	8-15
8-7	Interrupt Request Register.....	8-16
8-8	Interrupt Mask Register.....	8-17
8-9	Priority Mask Register.....	8-18
8-10	In-Service Register.....	8-19
8-11	Poll Register.....	8-20
8-12	Poll Status Register.....	8-21
8-13	End-of-Interrupt Register.....	8-22
8-14	Interrupt Status Register.....	8-23
8-15	Interrupt Control Unit in Slave Mode.....	8-24
8-16	Interrupt Sources in Slave Mode.....	8-25
8-17	Interrupt Vector Register (Slave Mode Only).....	8-27
8-18	End-of-Interrupt Register in Slave Mode.....	8-28
8-19	Request, Mask, and In-Service Registers.....	8-28
8-20	Interrupt Vectoring in Slave Mode.....	8-29
8-21	Interrupt Response Time in Slave Mode.....	8-30
9-1	Timer/Counter Unit Block Diagram.....	9-2
9-2	Counter Element Multiplexing and Timer Input Synchronization.....	9-3
9-3	Timers 0 and 1 Flow Chart.....	9-4
9-4	Timer/Counter Unit Output Modes.....	9-6
9-5	Timer 0 and Timer 1 Control Registers.....	9-7

FIGURES

Figure	Page
9-6	Timer 2 Control Register 9-9
9-7	Timer Count Registers..... 9-10
9-8	Timer Maxcount Compare Registers..... 9-11
9-9	TxOUT Signal Timing 9-15
10-1	Typical DMA Transfer..... 10-2
10-2	DMA Request Minimum Response Time 10-4
10-3	Source-Synchronized Transfers 10-5
10-4	Destination-Synchronized Transfers 10-6
10-5	Two-Channel DMA Module 10-9
10-6	Examples of DMA Priority..... 10-10
10-7	DMA Source Pointer (High-Order Bits)..... 10-11
10-8	DMA Source Pointer (Low-Order Bits) 10-12
10-9	DMA Destination Pointer (High-Order Bits) 10-13
10-10	DMA Destination Pointer (Low-Order Bits)..... 10-14
10-11	DMA Control Register..... 10-15
10-12	Transfer Count Register 10-19
11-1	80C187-Supported Data Types..... 11-8
11-2	80C186 Modular Core Family/80C187 System Configuration..... 11-9
11-3	80C187 Configuration with a Partially Buffered Bus..... 11-12
11-4	80C187 Exception Trapping via Processor Interrupt Pin..... 11-14
12-1	Entering/Leaving ONCE Mode 12-2
A-1	Formal Definition of ENTER A-3
A-2	Variable Access in Nested Procedures A-4
A-3	Stack Frame for Main at Level 1..... A-4
A-4	Stack Frame for Procedure A at Level 2 A-5
A-5	Stack Frame for Procedure B at Level 3 Called from A..... A-6
A-6	Stack Frame for Procedure C at Level 3 Called from B A-7
B-1	Input Synchronization Circuit..... B-1

TABLES

Table	Page
1-1 Comparison of 80C186 Modular Core Family Products	1-2
1-2 Related Documents and Software	1-3
2-1 Implicit Use of General Registers	2-5
2-2 Logical Address Sources	2-13
2-3 Data Transfer Instructions	2-18
2-4 Arithmetic Instructions	2-20
2-5 Arithmetic Interpretation of 8-Bit Numbers	2-21
2-6 Bit Manipulation Instructions	2-21
2-7 String Instructions	2-22
2-8 String Instruction Register and Flag Use	2-23
2-9 Program Transfer Instructions	2-25
2-10 Interpretation of Conditional Transfers	2-26
2-11 Processor Control Instructions	2-27
2-12 Supported Data Types	2-37
3-1 Bus Cycle Types	3-12
3-2 Read Bus Cycle Types	3-20
3-3 Read Cycle Critical Timing Parameters	3-20
3-4 Write Bus Cycle Types	3-23
3-5 Write Cycle Critical Timing Parameters	3-25
3-6 HALT Bus Cycle Pin States	3-29
3-7 Queue Status Signal Decoding	3-40
3-8 Signal Condition Entering HOLD	3-42
4-1 Peripheral Control Block	4-3
5-1 Suggested Values for Inductor L1 in Third Overtone Oscillator Circuit	5-4
5-2 Summary of Power Management Modes	5-23
6-1 Chip-Select Unit Registers	6-6
6-2 \overline{UCS} Block Size and Starting Address	6-12
6-3 \overline{LCS} Active Range	6-13
6-4 \overline{MCS} Active Range	6-13
6-5 \overline{MCS} Block Size and Start Address Restrictions	6-14
6-6 \overline{PCS} Active Range	6-15
7-1 Identification of Refresh Bus Cycles	7-5
8-1 Default Interrupt Priorities	8-3
8-2 Fixed Interrupt Types	8-9
8-3 Interrupt Control Unit Registers in Master Mode	8-11
8-4 Interrupt Control Unit Register Comparison	8-26
8-5 Slave Mode Fixed Interrupt Type Bits	8-26
9-1 Timer 0 and 1 Clock Sources	9-12
9-2 Timer Retriggering	9-13
11-1 80C187 Data Transfer Instructions	11-3
11-2 80C187 Arithmetic Instructions	11-4
11-3 80C187 Comparison Instructions	11-5
11-4 80C187 Transcendental Instructions	11-5
11-5 80C187 Constant Instructions	11-6

TABLES

Table	Page
11-6 80C187 Processor Control Instructions.....	11-6
11-7 80C187 I/O Port Assignments.....	11-10
C-1 Instruction Format Variables.....	C-1
C-2 Instruction Operands.....	C-2
C-3 Flag Bit Functions.....	C-3
C-4 Instruction Set.....	C-4
D-1 Operand Variables.....	D-1
D-2 Instruction Set Summary.....	D-2
D-3 Machine Instruction Decoding Guide.....	D-9
D-4 Mnemonic Encoding Matrix.....	D-20
D-5 Abbreviations for Mnemonic Encoding Matrix.....	D-22

EXAMPLES

Example		Page
5-1	Initializing the Power Management Unit for Idle or Powerdown Mode	5-16
5-2	Initializing the Power Management Unit for Power-Save Mode	5-22
6-1	Initializing the Chip-Select Unit.....	6-20
7-1	Initializing the Refresh Control Unit	7-11
8-1	Initializing the Interrupt Control Unit for Master Mode	8-31
9-1	Configuring a Real-Time Clock.....	9-18
9-2	Configuring a Square-Wave Generator	9-21
9-3	Configuring a Digital One-Shot.....	9-22
10-1	Initializing the DMA Unit	10-23
10-2	Timed DMA Transfers	10-26
11-1	Initialization Sequence for 80C187 Math Coprocessor	11-15
11-2	Floating Point Math Routine Using FSINCOS.....	11-16



1

Introduction



CHAPTER 1

INTRODUCTION

The 8086 microprocessor was first introduced in 1978 and gained rapid support as the microcomputer engine of choice. There are literally millions of 8086/8088-based systems in the world today. The amount of software written for the 8086/8088 is rivaled by no other architecture.

By the early 1980's, however, it was clear that a replacement for the 8086/8088 was necessary. An 8086/8088 system required dozens of support chips to implement even a moderately complex design. Intel recognized the need to integrate commonly used system peripherals onto the same silicon die as the CPU. In 1982 Intel addressed this need by introducing the 80186/80188 family of embedded microprocessors. The original 80186/80188 integrated an enhanced 8086/8088 CPU with six commonly used system peripherals. A parallel effort within Intel also gave rise to the 80286 microprocessor in 1982. The 80286 began the trend toward the very high performance Intel architecture that today includes the Intel386™, Intel486™ and Pentium™ microprocessors.

As technology advanced and turned toward small geometry CMOS processes, it became clear that a new 80186 was needed. In 1987 Intel announced the second generation of the 80186 family: the 80C186/C188. The 80C186 family is pin compatible with the 80186 family, while adding an enhanced feature set. The high-performance CHMOS III process allowed the 80C186 to run at twice the clock rate of the NMOS 80186, while consuming less than one-fourth the power.

The 80186 family took another major step in 1990 with the introduction of the 80C186EB family. The 80C186EB heralded many changes for the 80186 family. First, the enhanced 8086/8088 CPU was redesigned as a static, stand-alone module known as the 80C186 Modular Core. Second, the 80186 family peripherals were also redesigned as static modules with standard interfaces. The goal behind this redesign effort was to give Intel the capability to proliferate the 80186 family rapidly, in order to provide solutions for an even wider range of customer applications.

The 80C186EB/C188EB was the first product to use the new modular capability. The 80C186EB/C188EB includes a different peripheral set than the original 80186 family. Power consumption was dramatically reduced as a direct result of the static design, power management features and advanced CHMOS IV process. The 80C186EB/C188EB has found acceptance in a wide array of portable equipment ranging from cellular phones to personal organizers.

In 1991 the 80C186 Modular Core family was again extended with the introduction of three new products: the 80C186XL, the 80C186EA and the 80C186EC. The 80C186XL/C188XL is a higher performance, lower power replacement for the 80C186/C188. The 80C186EA/C188EA combines the feature set of the 80C186 with new power management features for power-critical applications. The 80C186EC/C188EC offers the highest level of integration of any of the 80C186 Modular Core family products, with 14 on-chip peripherals (see Table 1-1).

The 80C186 Modular Core family is the direct result of ten years of Intel development. It offers the designer the peace of mind of a well-established architecture with the benefits of state-of-the-art technology.

Table 1-1. Comparison of 80C186 Modular Core Family Products

Feature	80C186XL	80C186EA	80C186EB	80C186EC
Enhanced 8086 Instruction Set				
Low-Power Static Modular CPU				
Power-Save (Clock Divide) Mode				
Powerdown and Idle Modes				
80C187 Interface				
ONCE Mode				
Interrupt Control Unit				8259 Compatible
Timer/Counter Unit				
Chip-Select Unit			Enhanced	Enhanced
DMA Unit	2 Channel	2 Channel		4 Channel
Serial Communications Unit				
Refresh Control Unit			Enhanced	Enhanced
Watchdog Timer Unit				
I/O Ports			16 Total	22 Total

1.1 HOW TO USE THIS MANUAL

This manual uses phrases such as *80C186 Modular Core Family* or *80C188 Modular Core*, as well as references to specific products such as *80C188EA*. Each phrase refers to a specific set of 80C186 family products. The phrases and the products they refer to are as follows:

80C186 Modular Core Family: This phrase refers to any device that uses the modular 80C186/C188 CPU core architecture. At this time these include the 80C186EA/C188EA, 80C186EB/C188EB, 80C186EC/C188EC and 80C186XL/C188XL.

80C186 Modular Core: Without the word *family*, this phrase refers only to the 16-bit bus members of the 80C186 Modular Core Family.

80C188 Modular Core: This phrase refers to the 8-bit bus products.

80C188EC: A specific product reference refers only to the named device. For example, *On the 80C188EC...* refers strictly to the 80C188EC and not to any other device.

Each chapter covers a specific section of the device, beginning with the CPU core. Each peripheral chapter includes programming examples intended to aid in your understanding of device operation. Please read the comments carefully, as not all of the examples include all the code necessary for a specific application.

This user's guide is a supplement to the device data sheet. Specific timing values are not discussed in this guide. When designing a system, always consult the most recent version of the device data sheet for up-to-date specifications.

1.2 RELATED DOCUMENTS

The following table lists documents and software that are useful in designing systems that incorporate the 80C186 Modular Core Family. These documents are available through Intel Literature. In the U.S. and Canada, call 1-800-548-4725 to order. In Europe and other international locations, please contact your local Intel sales office or distributor.

NOTE

If you will be transferring a design from the 80186/80188 or 80C186/80C188 to the 80C186XL/80C188XL, refer to FaxBack Document No. 2132.

Table 1-2. Related Documents and Software

Document/Software Title	Document Order No.
Embedded Microprocessors (includes 186 family data sheets)	272396
186 Embedded Microprocessor Line Card	272079
80186/80188 High-Integration 16-Bit Microprocessor Data Sheet	272430
80C186XL/C188XL-20, -12 16-Bit High-Integration Embedded Microprocessor Data Sheet	272431
80C186EA/80C188EA-20, -12 and 80L186EA/80L188EA-13, -8 (low power versions) 16-Bit High-Integration Embedded Microprocessor Data Sheet	272432
80C186EB/80C188EB-20, -13 and 80L186EB/80L188EB-13, -8 (low power versions) 16-Bit High-Integration Embedded Microprocessor Data Sheet	272433
80C186EC/80C188EC-20, -13 and 80L186EC/80L188EC-13, -8 (low power versions) 16-Bit High-Integration Embedded Microprocessor Data Sheet	272434
80C187 80-Bit Math Coprocessor Data Sheet	270640
Low Voltage Embedded Design	272324
80C186/C188, 80C186XL/C188XL Microprocessor User's Manual	272164
80C186EA/80C188EA Microprocessor User's Manual	270950
80C186EB/80C188EB Microprocessor User's Manual	270830
80C186EC/80C188EC Microprocessor User's Manual	272047
8086/8088/8087/80186/80188 Programmer's Pocket Reference Guide	231017

Table 1-2. Related Documents and Software (Continued)

Document/Software Title	Document Order No.
8086/8088 User's Manual Programmer's and Hardware Reference Manual	240487
ApBUILDER Software	272216
80C186EA Hypertext Manual	272275
80C186EB Hypertext Manual	272296
80C186EC Hypertext Manual	272298
80C186XL Hypertext Manual	272630
ZCON - Z80 Code Converter	Available on BBS

1.3 ELECTRONIC SUPPORT SYSTEMS

Intel's FaxBack* service and application BBS provide up-to-date technical information. Intel also maintains several forums on CompuServe and offers a variety of information on the World Wide Web. These systems are available 24 hours a day, 7 days a week, providing technical information whenever you need it.

1.3.1 FaxBack Service

FaxBack is an on-demand publishing system that sends documents to your fax machine. You can get product announcements, change notifications, product literature, device characteristics, design recommendations, and quality and reliability information from FaxBack 24 hours a day, 7 days a week.

1-800-628-2283	U.S. and Canada
916-356-3105	U.S., Canada, Japan, Asia Pacific
44(0)1793-496646	Europe

Think of the FaxBack service as a library of technical documents that you can access with your phone. Just dial the telephone number and respond to the system prompts. After you select a document, the system sends a copy to your fax machine.

Each document has an order number and is listed in a subject catalog. The first time you use FaxBack, you should order the appropriate subject catalogs to get a complete list of document order numbers. Catalogs are updated twice monthly. In addition, daily update catalogs list the title, status, and order number of each document that has been added, revised, or deleted during the past eight weeks. To receive the update for a subject catalog, enter the subject catalog number followed by a zero. For example, for the complete microcontroller and flash catalog, request document number 2; for the daily update to the microcontroller and flash catalog, request document number 20.

The following catalogs and information are available at the time of publication:

1. *Solutions OEM* subscription form
2. Microcontroller and flash catalog

3. Development tools catalog
4. Systems catalog
5. Multimedia catalog
6. Multibus and iRMX® software catalog and BBS file listings
7. Microprocessor, PCI, and peripheral catalog
8. Quality and reliability and change notification catalog
9. iAL (Intel Architecture Labs) technology catalog

1.3.2 Bulletin Board System (BBS)

The bulletin board system (BBS) lets you download files to your computer. The application BBS has the latest *ApBUILDER* software, hypertext manuals and datasheets, software drivers, firmware upgrades, application notes and utilities, and quality and reliability data.

916-356-3600	U.S., Canada, Japan, Asia Pacific (up to 19.2 Kbaud)
916-356-7209	U.S., Canada, Japan, Asia Pacific (2400 baud only)
44(0)1793-496340	Europe

The toll-free BBS (available in the U.S. and Canada) offers lists of documents available from FaxBack, a master list of files available from the application BBS, and a BBS user's guide. The BBS file listing is also available from FaxBack (catalog number 6; see page 1-4 for phone numbers and a description of the FaxBack service).

1-800-897-2536	U.S. and Canada only
----------------	----------------------

Any customer with a modem and computer can access the BBS. The system provides automatic configuration support for 1200- through 19200-baud modems. Typical modem settings are 14400 baud, no parity, 8 data bits, and 1 stop bit (14400, N, 8, 1).

To access the BBS, just dial the telephone number and respond to the system prompts. During your first session, the system asks you to register with the system operator by entering your name and location. The system operator will set up your access account within 24 hours. At that time, you can access the files on the BBS.

NOTE

If you encounter any difficulty accessing the high-speed modem, try the dedicated 2400-baud modem. Use these modem settings: 2400, N, 8, 1.

1.3.2.1 How to Find *ApBUILDER* Software and Hypertext Documents on the BBS

The latest *ApBUILDER* files and hypertext manuals and datasheets are available first from the BBS. To access the files, complete these steps:

1. Type **F** from the BBS Main menu. The BBS displays the Intel Apps Files menu.

INTRODUCTION

2. Type **L** and press <Enter>. The BBS displays the list of areas and prompts for the area number.
3. Type **25** and press <Enter> to select *ApBUILDER/Hypertext*. The BBS displays several options: one for *ApBUILDER* software and the others for hypertext documents for specific product families.
4. Type **1** and press <Enter> to list the latest *ApBUILDER* files.
5. Type the file numbers to select the files you wish to download (for example, **1,6** for files 1 and 6 or **3-7** for files 3, 4, 5, 6, and 7) and press <Enter>. The BBS displays the approximate time required to download the selected files and gives you the option to download them.

1.3.3 CompuServe Forums

The CompuServe forums provide a means for you to gather information, share discoveries, and debate issues. Type "go intel" for access. For information about CompuServe access and service fees, call CompuServe at 1-800-848-8199 (U.S.) or 614-529-1340 (outside the U.S.).

1.3.4 World Wide Web

We offer a variety of information through the World Wide Web (<http://www.intel.com/>). Select "Embedded Design Products" from the Intel home page.

1.4 TECHNICAL SUPPORT

In the U.S. and Canada, technical support representatives are available to answer your questions between 5 a.m. and 5 p.m. PST. You can also fax your questions to us. (Please include your voice telephone number and indicate whether you prefer a response by phone or by fax). Outside the U.S. and Canada, please contact your local distributor.

1-800-628-8686	U.S. and Canada
916-356-7599	U.S. and Canada
916-356-6100 (fax)	U.S. and Canada

1.5 PRODUCT LITERATURE

You can order product literature from the following Intel literature centers.

1-800-548-4725	U.S. and Canada
708-296-9333	U.S. (from overseas)
44(0)1793-431155	Europe (U.K.)
44(0)1793-421333	Germany
44(0)1793-421777	France
81(0)120-47-88-32	Japan (fax only)



2

Overview of the 80C186 Family Architecture



CHAPTER 2

OVERVIEW OF THE 80C186 FAMILY ARCHITECTURE

The 80C186 Modular Microprocessor Core shares a common base architecture with the 8086, 8088, 80186, 80188, 80286, Intel386™ and Intel486™ processors. The 80C186 Modular Core maintains full object-code compatibility with the 8086/8088 family of 16-bit microprocessors, while adding hardware and software performance enhancements. Most instructions require fewer clocks to execute on the 80C186 Modular Core because of hardware enhancements in the Bus Interface Unit and the Execution Unit. Several additional instructions simplify programming and reduce code size (see Appendix A, “80C186 Instruction Set Additions and Extensions”).

2.1 ARCHITECTURAL OVERVIEW

The 80C186 Modular Microprocessor Core incorporates two separate processing units: an Execution Unit (EU) and a Bus Interface Unit (BIU). The Execution Unit is functionally identical among all family members. The Bus Interface Unit is configured for a 16-bit external data bus for the 80C186 core and an 8-bit external data bus for the 80C188 core. The two units interface via an instruction prefetch queue.

The Execution Unit executes instructions; the Bus Interface Unit fetches instructions, reads operands and writes results. Whenever the Execution Unit requires another opcode byte, it takes the byte out of the prefetch queue. The two units can operate independently of one another and are able, under most circumstances, to overlap instruction fetches and execution.

The 80C186 Modular Core family has a 16-bit Arithmetic Logic Unit (ALU). The Arithmetic Logic Unit performs 8-bit or 16-bit arithmetic and logical operations. It provides for data movement between registers, memory and I/O space.

The 80C186 Modular Core family CPU allows for high-speed data transfer from one area of memory to another using string move instructions and between an I/O port and memory using block I/O instructions. The CPU also provides many conditional branch and control instructions.

The 80C186 Modular Core architecture features 14 basic registers grouped as general registers, segment registers, pointer registers and status and control registers. The four 16-bit general-purpose registers (AX, BX, CX and DX) can be used as operands for most arithmetic operations as either 8- or 16-bit units. The four 16-bit pointer registers (SI, DI, BP and SP) can be used in arithmetic operations and in accessing memory-based variables. Four 16-bit segment registers (CS, DS, SS and ES) allow simple memory partitioning to aid modular programming. The status and control registers consist of an Instruction Pointer (IP) and the Processor Status Word (PSW) register, which contains flag bits. Figure 2-1 is a simplified CPU block diagram.

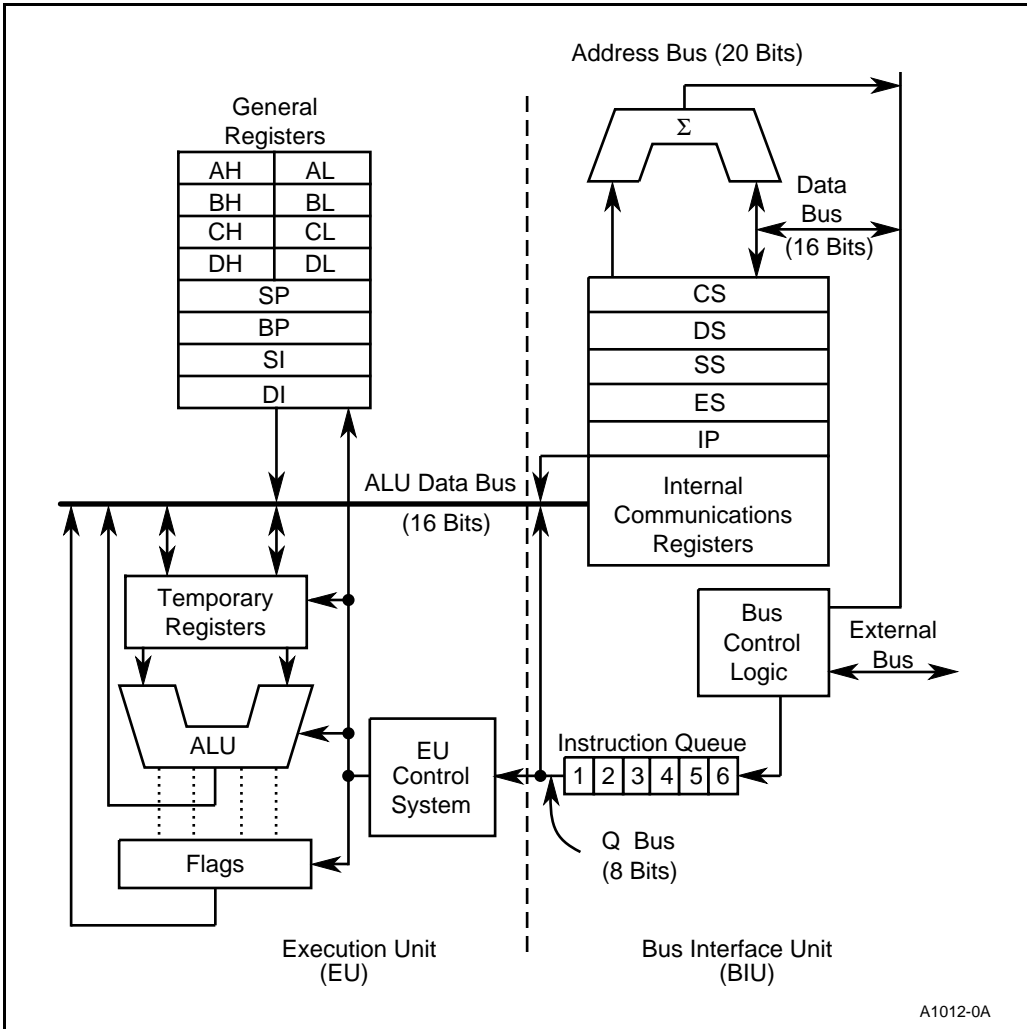

Figure 2-1. Simplified Functional Block Diagram of the 80C186 Family CPU

2.1.1 Execution Unit

The Execution Unit executes all instructions, provides data and addresses to the Bus Interface Unit and manipulates the general registers and the Processor Status Word. The 16-bit ALU within the Execution Unit maintains the CPU status and control flags and manipulates the general registers and instruction operands. All registers and data paths in the Execution Unit are 16 bits wide for fast internal transfers.

The Execution Unit does not connect directly to the system bus. It obtains instructions from a queue maintained by the Bus Interface Unit. When an instruction requires access to memory or a peripheral device, the Execution Unit requests the Bus Interface Unit to read and write data. Addresses manipulated by the Execution Unit are 16 bits wide. The Bus Interface Unit, however, performs an address calculation that allows the Execution Unit to access the full megabyte of memory space.

To execute an instruction, the Execution Unit must first fetch the object code byte from the instruction queue and then execute the instruction. If the queue is empty when the Execution Unit is ready to fetch an instruction byte, the Execution Unit waits for the Bus Interface Unit to fetch the instruction byte.

2.1.2 Bus Interface Unit

The 80C186 Modular Core and 80C188 Modular Core Bus Interface Units are functionally identical. They are implemented differently to match the structure and performance characteristics of their respective system buses. The Bus Interface Unit executes all external bus cycles. This unit consists of the segment registers, the Instruction Pointer, the instruction code queue and several miscellaneous registers. The Bus Interface Unit transfers data to and from the Execution Unit on the ALU data bus.

The Bus Interface Unit generates a 20-bit physical address in a dedicated adder. The adder shifts a 16-bit segment value left 4 bits and then adds a 16-bit offset. This offset is derived from combinations of the pointer registers, the Instruction Pointer and immediate values (see Figure 2-2). Any carry from this addition is ignored.

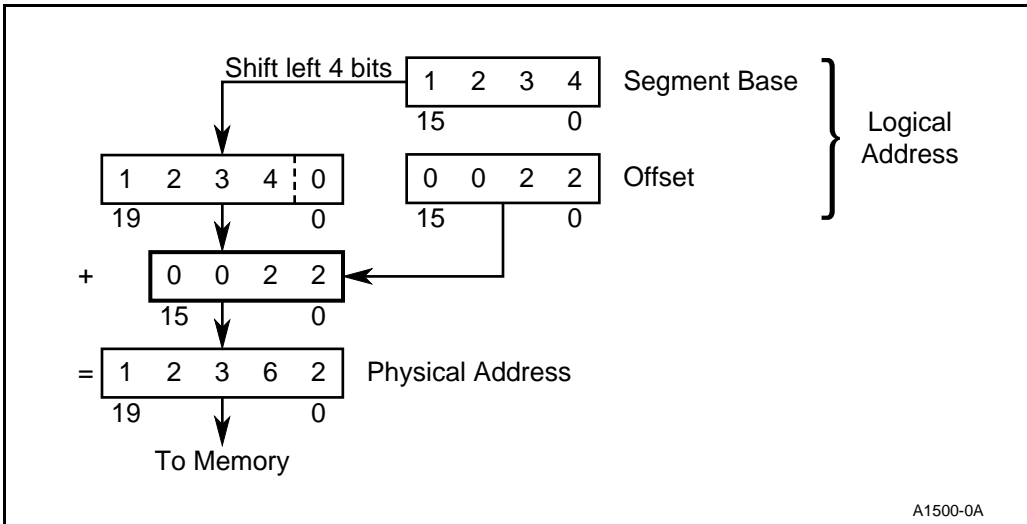

Figure 2-2. Physical Address Generation

During periods when the Execution Unit is busy executing instructions, the Bus Interface Unit sequentially prefetches instructions from memory. As long as the prefetch queue is partially full, the Execution Unit fetches instructions.

2.1.3 General Registers

The 80C186 Modular Core family CPU has eight 16-bit general registers (see Figure 2-3). The general registers are subdivided into two sets of four registers. These sets are the data registers (also called the H & L group for high and low) and the pointer and index registers (also called the P & I group).

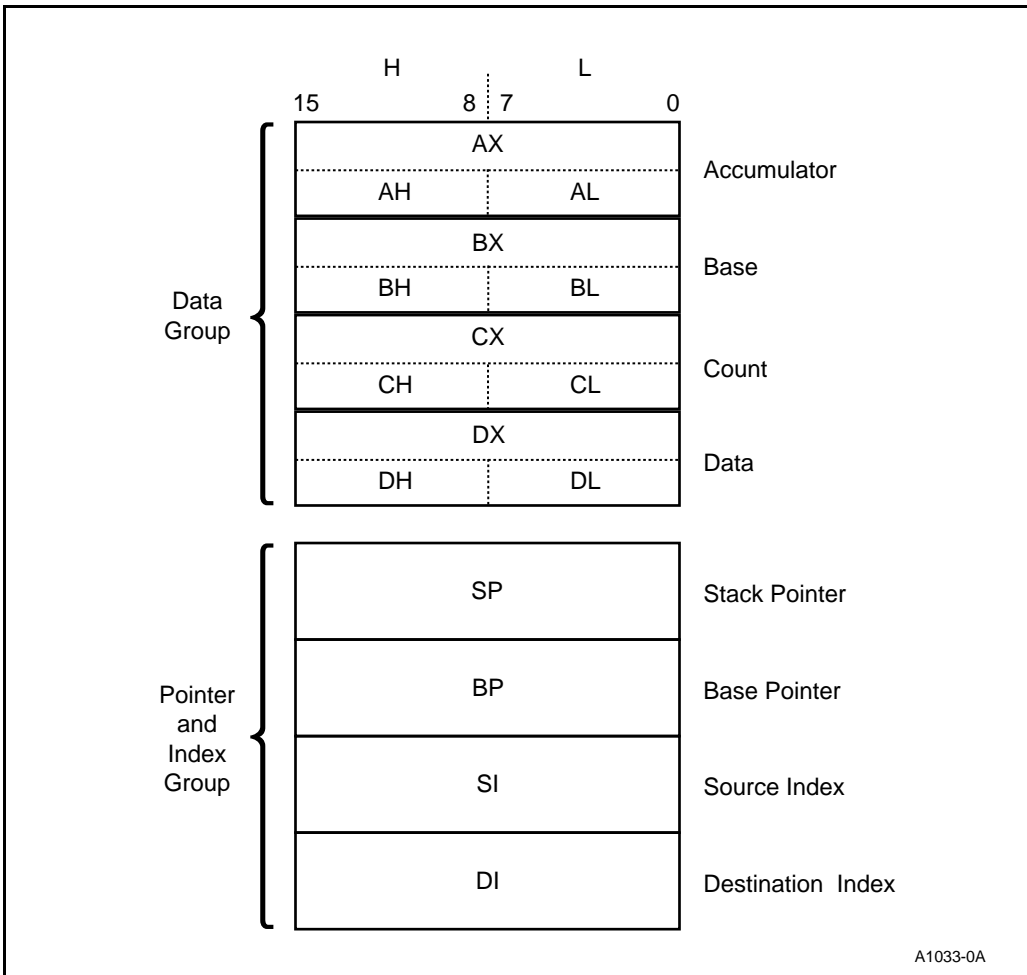

Figure 2-3. General Registers

The data registers can be addressed by their upper or lower halves. Each data register can be used interchangeably as a 16-bit register or two 8-bit registers. The pointer registers are always accessed as 16-bit values. The CPU can use data registers without constraint in most arithmetic and logic operations. Arithmetic and logic operations can also use the pointer and index registers. Some instructions use certain registers implicitly (see Table 2-1), allowing compact encoding.

Table 2-1. Implicit Use of General Registers

Register	Operations
AX	Word Multiply, Word Divide, Word I/O
AL	Byte Multiply, Byte Divide, Byte I/O, Translate, Decimal Arithmetic
AH	Byte Multiply, Byte Divide
BX	Translate
CX	String Operations, Loops
CL	Variable Shift and Rotate
DX	Word Multiply, Word Divide, Indirect I/O
SP	Stack Operations
SI	String Operations
DI	String Operations

The contents of the general-purpose registers are undefined following a processor reset.

2.1.4 Segment Registers

The 80C186 Modular Core family memory space is 1 Mbyte in size and divided into logical segments of up to 64 Kbytes each. The CPU has direct access to four segments at a time. The segment registers contain the base addresses (starting locations) of these memory segments (see Figure 2-4). The CS register points to the current code segment, which contains instructions to be fetched. The SS register points to the current stack segment, which is used for all stack operations. The DS register points to the current data segment, which generally contains program variables. The ES register points to the current extra segment, which is typically used for data storage. The CS register initializes to 0FFFFH, and the SS, DS and ES registers initialize to 0000H. Programs can access and manipulate the segment registers with several instructions.

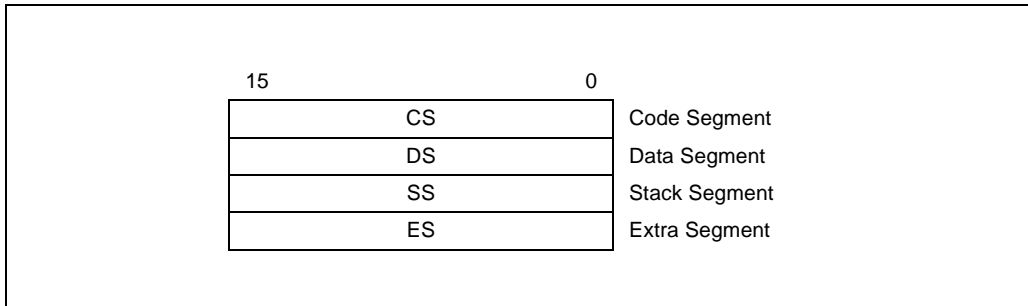

Figure 2-4. Segment Registers

2.1.5 Instruction Pointer

The Bus Interface Unit updates the 16-bit Instruction Pointer (IP) register so it contains the offset of the next instruction to be fetched. Programs do not have direct access to the Instruction Pointer, but it can change, be saved or be restored as a result of program execution. For example, if the Instruction Pointer is saved on the stack, it is first automatically adjusted to point to the next instruction to be executed.

Reset initializes the Instruction Pointer to 0000H. The CS and IP values comprise a starting execution address of 0FFFF0H (see “Logical Addresses” on page 2-10 for a description of address formation).

2.1.6 Flags

The 80C186 Modular Core family has six status flags (see Figure 2-5) that the Execution Unit posts as the result of arithmetic or logical operations. Program branch instructions allow a program to alter its execution depending on conditions flagged by a prior operation. Different instructions affect the status flags differently, generally reflecting the following states:

- If the Auxiliary Flag (AF) is set, there has been a carry out from the low nibble into the high nibble or a borrow from the high nibble into the low nibble of an 8-bit quantity (low-order byte of a 16-bit quantity). This flag is used by decimal arithmetic instructions.
- If the Carry Flag (CF) is set, there has been a carry out of or a borrow into the high-order bit of the instruction result (8- or 16-bit). This flag is used by instructions that add or subtract multibyte numbers. Rotate instructions can also isolate a bit in memory or a register by placing it in the Carry Flag.
- If the Overflow Flag (OF) is set, an arithmetic overflow has occurred. A significant digit has been lost because the size of the result exceeded the capacity of its destination location. An Interrupt On Overflow instruction is available that will generate an interrupt in this situation.
- If the Sign Flag (SF) is set, the high-order bit of the result is a 1. Since negative binary numbers are represented in standard two's complement notation, SF indicates the sign of the result (0 = positive, 1 = negative).
- If the Parity Flag (PF) is set, the result has even parity, an even number of 1 bits. This flag can be used to check for data transmission errors.
- If the Zero Flag (ZF) is set, the result of the operation is zero.

Additional control flags (see Figure 2-5) can be set or cleared by programs to alter processor operations:

- Setting the Direction Flag (DF) causes string operations to auto-decrement. Strings are processed from high address to low address (or “right to left”). Clearing DF causes string operations to auto-increment. Strings are processed from low address to high address (or “left to right”).
- Setting the Interrupt Enable Flag (IF) allows the CPU to recognize maskable external or internal interrupt requests. Clearing IF disables these interrupts. The Interrupt Enable Flag has no effect on software interrupts or non-maskable interrupts.
- Setting the Trap Flag (TF) bit puts the processor into single-step mode for debugging. In this mode, the CPU automatically generates an interrupt after each instruction. This allows a program to be inspected instruction by instruction during execution.

The status and control flags are contained in a 16-bit Processor Status Word (see Figure 2-5). Reset initializes the Processor Status Word to 0F000H.

2.1.7 Memory Segmentation

Programs for the 80C186 Modular Core family view the 1 Mbyte memory space as a group of user-defined segments. A segment is a logical unit of memory that can be up to 64 Kbytes long. Each segment is composed of contiguous memory locations. Segments are independent and separately addressable. Software assigns every segment a base address (starting location) in memory space. All segments begin on 16-byte memory boundaries. There are no other restrictions on segment locations. Segments can be adjacent, disjoint, partially overlapped or fully overlapped (see Figure 2-6). A physical memory location can be mapped into (covered by) one or more logical segments.



Register Name: Processor Status Word
Register Mnemonic: PSW (FLAGS)
Register Function: Posts CPU status information.

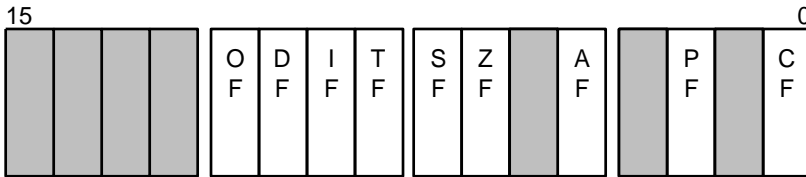

A1035-0A

Bit Mnemonic	Bit Name	Reset State	Function
OF	Overflow Flag	0	If OF is set, an arithmetic overflow has occurred.
DF	Direction Flag	0	If DF is set, string instructions are processed high address to low address. If DF is clear, strings are processed low address to high address.
IF	Interrupt Enable Flag	0	If IF is set, the CPU recognizes maskable interrupt requests. If IF is clear, maskable interrupts are ignored.
TF	Trap Flag	0	If TF is set, the processor enters single-step mode.
SF	Sign Flag	0	If SF is set, the high-order bit of the result of an operation is 1, indicating it is negative.
ZF	Zero Flag	0	If ZF is set, the result of an operation is zero.
AF	Auxiliary Flag	0	If AF is set, there has been a carry from the low nibble to the high or a borrow from the high nibble to the low nibble of an 8-bit quantity. Used in BCD operations.
PF	Parity Flag	0	If PF is set, the result of an operation has even parity.
CF	Carry Flag	0	If CF is set, there has been a carry out of, or a borrow into, the high-order bit of the result of an instruction.

NOTE: Reserved register bits are shown with gray shading. Reserved bits must be written to a logic zero to ensure compatibility with future Intel products.

Figure 2-5. Processor Status Word

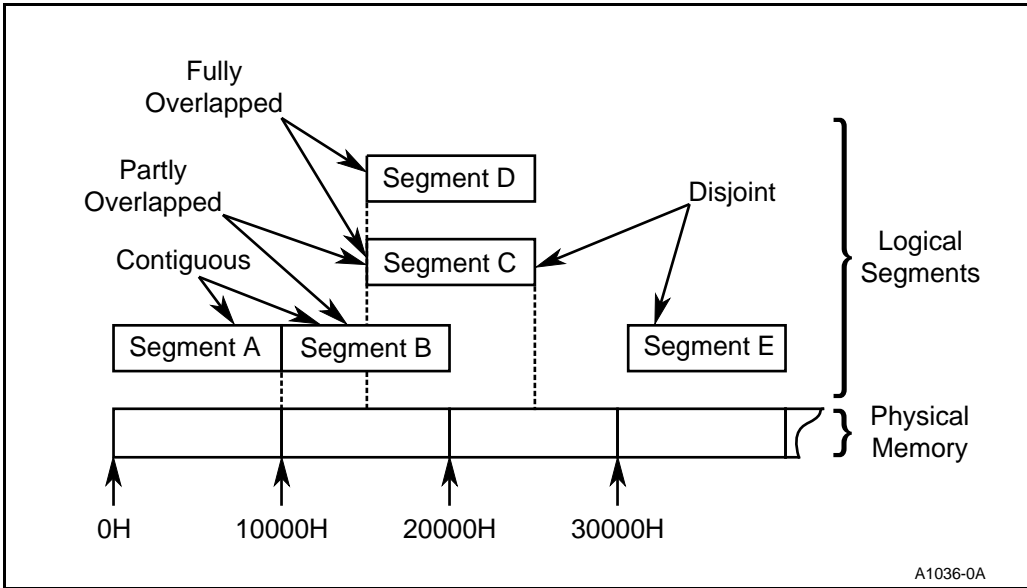

Figure 2-6. Segment Locations in Physical Memory

The four segment registers point to four “currently addressable” segments (see Figure 2-7). The currently addressable segments provide a work space consisting of 64 Kbytes for code, a 64 Kbytes for stack and 128 Kbytes for data storage. Programs access code and data in another segment by updating the segment register to point to the new segment.

2.1.8 Logical Addresses

It is useful to think of every memory location as having two kinds of addresses, physical and logical. A physical address is a 20-bit value that identifies a unique byte location in the memory space. Physical addresses range from 0H to 0FFFFFFH. All exchanges between the CPU and memory use physical addresses.

Programs deal with logical rather than physical addresses. Program code can be developed without prior knowledge of where the code will be located in memory. A logical address consists of a segment base value and an offset value. For any given memory location, the segment base value locates the first byte of the segment. The offset value represents the distance, in bytes, of the target location from the beginning of the segment. Segment base and offset values are unsigned 16-bit quantities. Many different logical addresses can map to the same physical location. In Figure 2-8, physical memory location 2C3H is contained in two different overlapping segments, one beginning at 2B0H and the other at 2C0H.

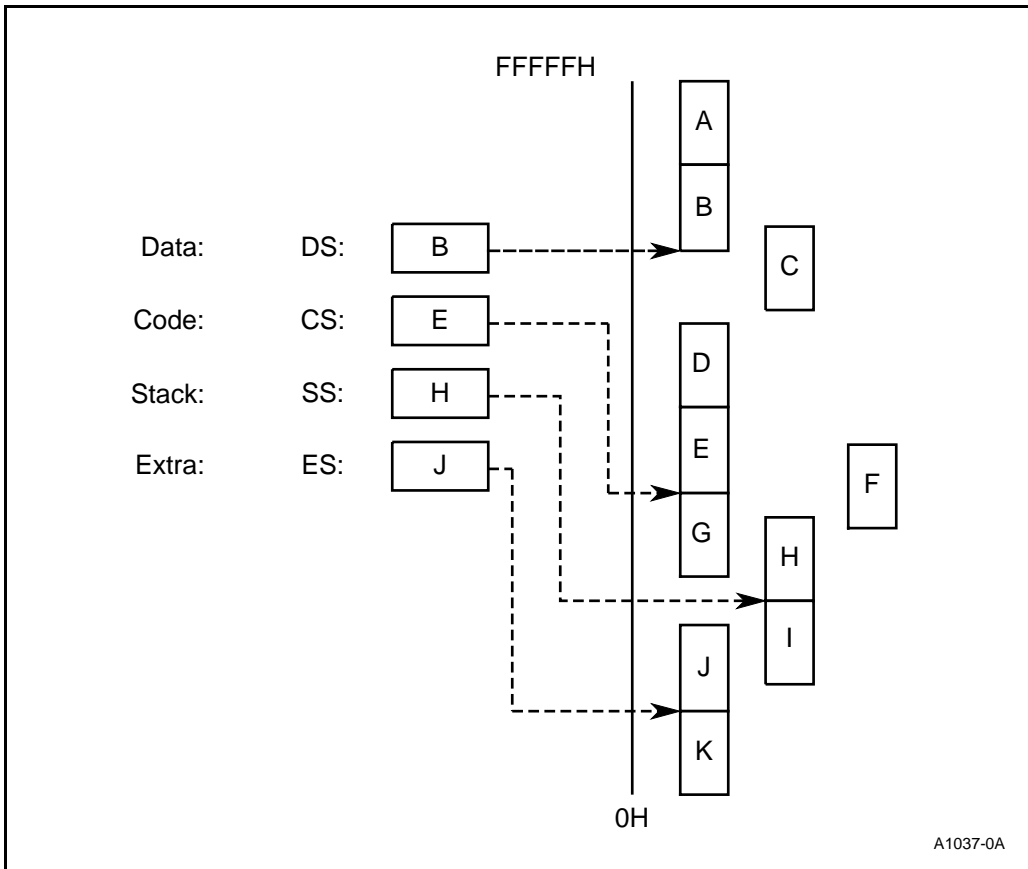

Figure 2-7. Currently Addressable Segments

The segment register is automatically selected according to the rules in Table 2-2. All information in one segment type generally shares the same logical attributes (e.g., code or data). This leads to programs that are shorter, faster and better structured.

The Bus Interface Unit must obtain the logical address before generating the physical address. The logical address of a memory location can come from different sources, depending on the type of reference that is being made (see Table 2-2).

Segment registers always hold the segment base addresses. The Bus Interface Unit determines which segment register contains the base address according to the type of memory reference made. However, the programmer can explicitly direct the Bus Interface Unit to use any currently addressable segment (except for the destination operand of a string instruction). In assembly language, this is done by preceding an instruction with a segment override prefix.

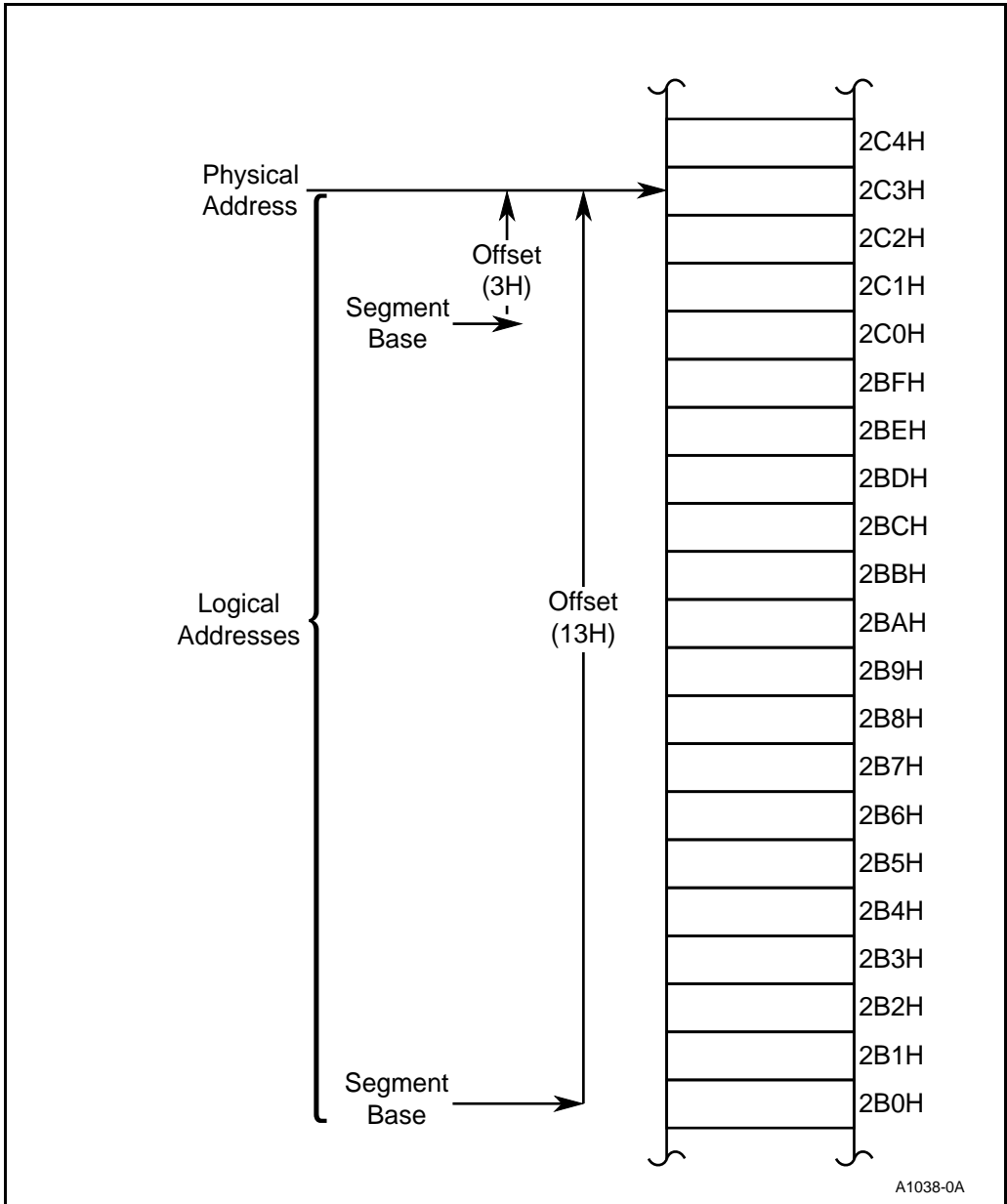

Figure 2-8. Logical and Physical Address

Table 2-2. Logical Address Sources

Type of Memory Reference	Default Segment Base	Alternate Segment Base	Offset
Instruction Fetch	CS	NONE	IP
Stack Operation	SS	NONE	SP
Variable (except following)	DS	CS, ES, SS	Effective Address
String Source	DS	CS, ES, SS	SI
String Destination	ES	NONE	DI
BP Used as Base Register	SS	CS, DS, ES	Effective Address

Instructions are always fetched from the current code segment. The IP register contains the instruction’s offset from the beginning of the segment. Stack instructions always operate on the current stack segment. The Stack Pointer (SP) register contains the offset of the top of the stack from the base of the stack. Most variables (memory operands) are assumed to reside in the current data segment, but a program can instruct the Bus Interface Unit to override this assumption. Often, the offset of a memory variable is not directly available and must be calculated at execution time. The addressing mode specified in the instruction determines how this offset is calculated (see “Addressing Modes” on page 2-27). The result is called the operand’s Effective Address (EA).

Strings are addressed differently than other variables. The source operand of a string instruction is assumed to lie in the current data segment. However, the program can use another currently addressable segment. The operand’s offset is taken from the Source Index (SI) register. The destination operand of a string instruction always resides in the current extra segment. The destination’s offset is taken from the Destination Index (DI) register. The string instructions automatically adjust the SI and DI registers as they process the strings one byte or word at a time.

When an instruction designates the Base Pointer (BP) register as a base register, the variable is assumed to reside in the current stack segment. The BP register provides a convenient way to access data on the stack. The BP register can also be used to access data in any other currently addressable segment.

2.1.9 Dynamically Relocatable Code

The segmented memory structure of the 80C186 Modular Core family allows creation of dynamically relocatable (position-independent) programs. Dynamic relocation allows a multiprogramming or multitasking system to make effective use of available memory. The processor can write inactive programs to a disk and reallocate the space they occupied to other programs. A disk-resident program can then be read back into available memory locations and restarted whenever it is needed. If a program needs a large contiguous block of storage and the total amount is available only in non-adjacent fragments, other program segments can be compacted to free enough continuous space. This process is illustrated in Figure 2-9.

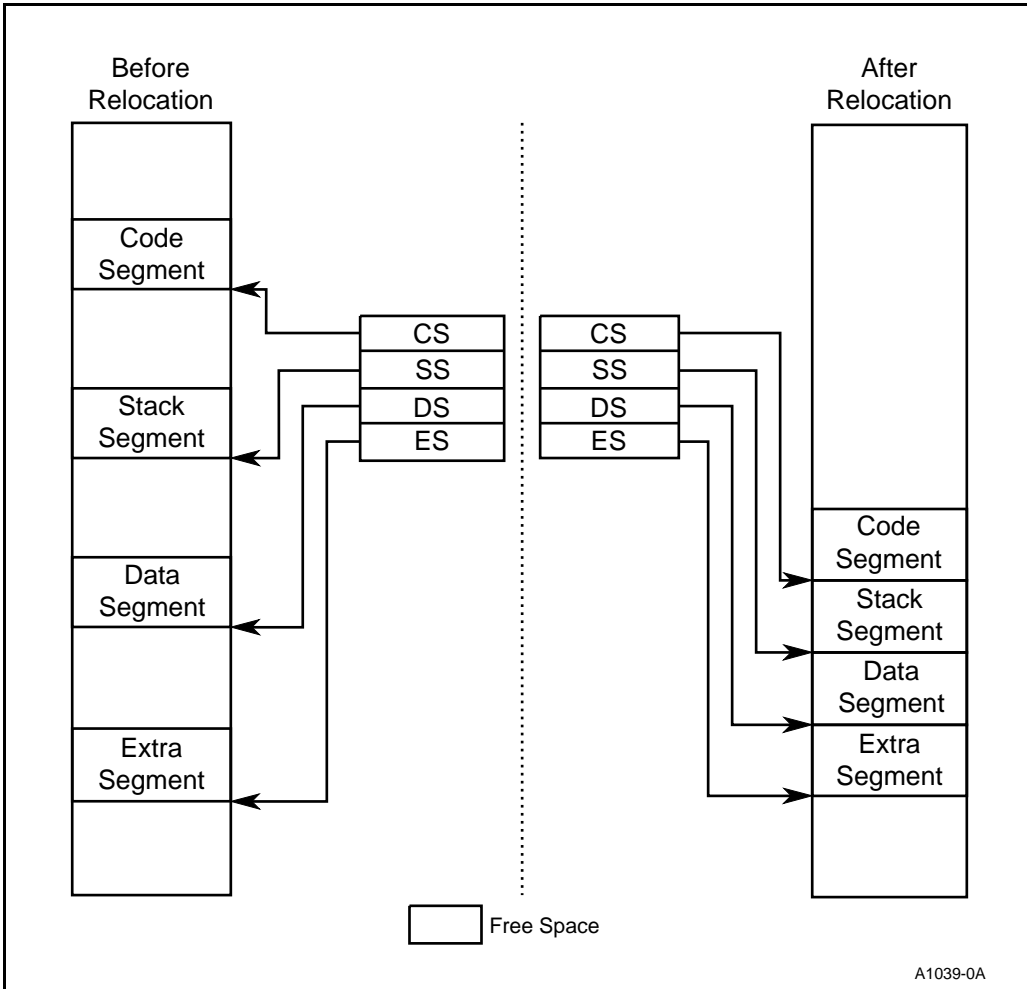

Figure 2-9. Dynamic Code Relocation

To be dynamically relocatable, a program must not load or alter its segment registers and must not transfer directly to a location outside the current code segment. All program offsets must be relative to the segment registers. This allows the program to be moved anywhere in memory, provided that the segment registers are updated to point to the new base addresses.

2.1.10 Stack Implementation

Stacks in the 80C186 Modular Core family reside in memory space. They are located by the Stack Segment register (SS) and the Stack Pointer (SP). A system can have multiple stacks, but only one stack is directly addressable at a time. A stack can be up to 64 Kbytes long, the maximum length of a segment. Growing a stack segment beyond 64 Kbytes overwrites the beginning of the segment. The SS register contains the base address of the current stack. The top of the stack, not the base address, is the origination point of the stack. The SP register contains an offset that points to the Top of Stack (TOS).

Stacks are 16 bits wide. Instructions operating on a stack add and remove stack elements one word at a time. An element is pushed onto the stack (see Figure 2-10) by first decrementing the SP register by 2 and then writing the data word. An element is popped off the stack by copying it from the top of the stack and then incrementing the SP register by 2. The stack grows down in memory toward its base address. Stack operations never move or erase elements on the stack. The top of the stack changes only as a result of updating the stack pointer.

2.1.11 Reserved Memory and I/O Space

Two specific areas in memory and one area in I/O space are reserved in the 80C186 Core family.

- Locations 0H through 3FFH in low memory are used for the Interrupt Vector Table. Programs should not be loaded here.
- Locations 0FFFF0H through 0FFFFFFH in high memory are used for system reset code because the processor begins execution at 0FFFF0H.
- Locations 0F8H through 0FFH in I/O space are reserved for communication with other Intel hardware products and must not be used. On the 80C186 core, these addresses are used as I/O ports for the 80C187 numerics processor extension.

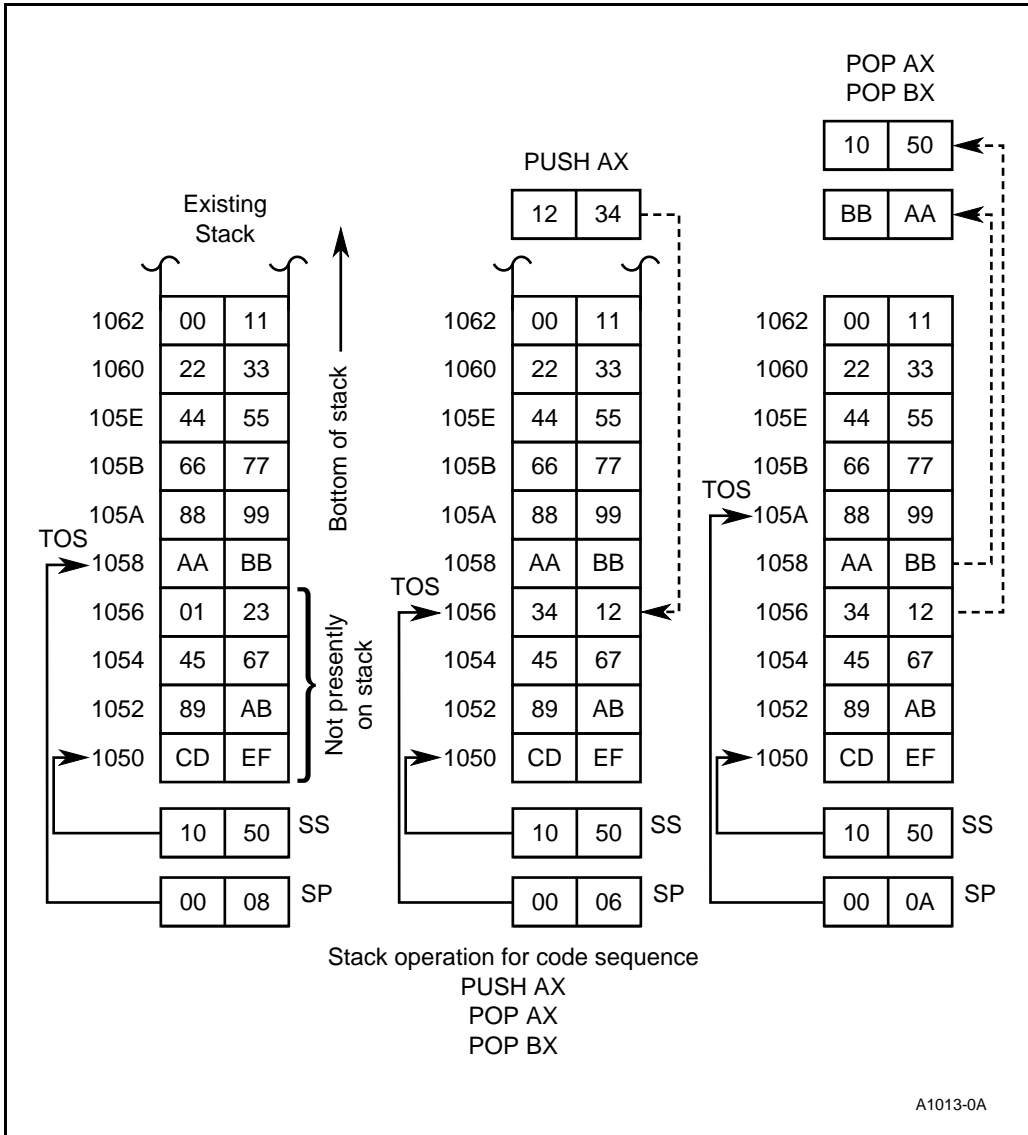

Figure 2-10. Stack Operation

2.2 SOFTWARE OVERVIEW

All 80C186 Modular Core family members execute the same instructions. This includes all the 8086/8088 instructions plus several additions and enhancements (see Appendix A, “80C186 Instruction Set Additions and Extensions”). The following sections describe the instructions by category and provide a detailed discussion of the operand addressing modes.

Software for 80C186 core family systems need not be written in assembly language. The processor provides direct hardware support for programs written in the many high-level languages available. The hardware addressing modes provide straightforward implementations of based variables, arrays, arrays of structures and other high-level language data constructs. A powerful set of memory-to-memory string operations allow efficient character data manipulation. Finally, routines with critical performance requirements can be written in assembly language and linked with high-level code.

2.2.1 Instruction Set

The 80C186 Modular Core family instructions treat different types of operands uniformly. Nearly every instruction can operate on either byte or word data. Register, memory and immediate operands can be specified interchangeably in most instructions. Immediate values are exceptions: they must serve as source operands and not destination operands. Memory variables can be manipulated (added to, subtracted from, shifted, compared) without being moved into and out of registers. This saves instructions, registers and execution time in assembly language programs. In high-level languages, where most variables are memory-based, compilers can produce faster and shorter object programs.

The 80C186 Modular Core family instruction set can be viewed as existing on two levels. One is the assembly level and the other is the machine level. To the assembly language programmer, the 80C186 Modular Core family appears to have about 100 instructions. One MOV (data move) instruction, for example, transfers a byte or a word from a register, a memory location or an immediate value to either a register or a memory location. The 80C186 Modular Core family CPUs, however, recognize 28 different machine versions of the MOV instruction.

The two levels of instruction sets address two requirements: efficiency and simplicity. Approximately 300 forms of machine-level instructions make very efficient use of storage. For example, the machine instruction that increments a memory operand is three or four bytes long because the address of the operand must be encoded in the instruction. Incrementing a register, however, requires less information, so the instruction can be shorter. The 80C186 Core family has eight single-byte machine-level instructions that increment different 16-bit registers.

The assembly level instructions simplify the programmer’s view of the instruction set. The programmer writes one form of an INC (increment) instruction and the assembler examines the operand to determine which machine level instruction to generate. The following paragraphs provide a functional description of the assembly-level instructions.

2.2.1.1 Data Transfer Instructions

The instruction set contains 14 data transfer instructions. These instructions move single bytes and words between memory and registers. They also move single bytes and words between the AL or AX register and I/O ports. Table 2-3 lists the four types of data transfer instructions and their functions.

Table 2-3. Data Transfer Instructions

General-Purpose	
MOV	Move byte or word
PUSH	Push word onto stack
POP	Pop word off stack
PUSHA	Push registers onto stack
POPA	Pop registers off stack
XCHG	Exchange byte or word
XLAT	Translate byte
Input/Output	
IN	Input byte or word
OUT	Output byte or word
Address Object and Stack Frame	
LEA	Load effective address
LDS	Load pointer using DS
LES	Load pointer using ES
ENTER	Build stack frame
LEAVE	Tear down stack frame
Flag Transfer	
LAHF	Load AH register from flags
SAHF	Store AH register in flags
PUSHF	Push flags from stack
POPF	Pop flags off stack

Data transfer instructions are categorized as general purpose, input/output, address object and flag transfer. The stack manipulation instructions, used for transferring flag contents and instructions used for loading segment registers are also included in this group. Figure 2-11 shows the flag storage formats. The address object instructions manipulate the addresses of variables instead of the values of the variables.

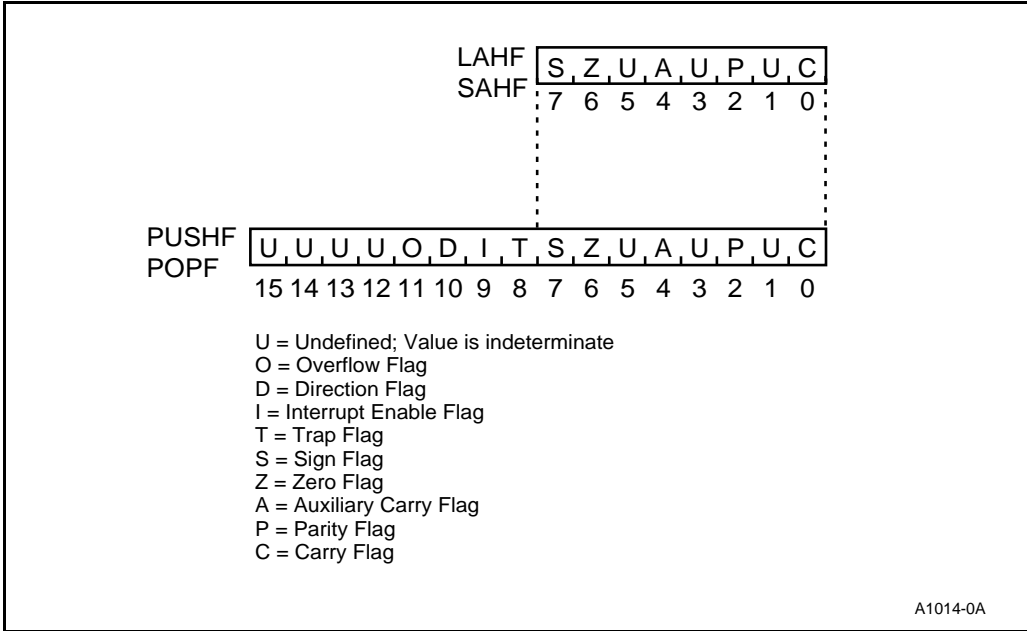

Figure 2-11. Flag Storage Format

2.2.1.2 Arithmetic Instructions

The arithmetic instructions (see Table 2-4) operate on four types of numbers:

- Unsigned binary
- Signed binary (integers)
- Unsigned packed decimal
- Unsigned unpacked decimal

Table 2-5 shows the interpretations of various bit patterns according to number type. Binary numbers can be 8 or 16 bits long. Decimal numbers are stored in bytes, two digits per byte for packed decimal and one digit per byte for unpacked decimal. The processor assumes that the operands in arithmetic instructions contain data that represents valid numbers for that instruction. Invalid data may produce unpredictable results. The Execution Unit analyzes the results of arithmetic instructions and adjusts status flags accordingly.

Table 2-4. Arithmetic Instructions

Addition	
ADD	Add byte or word
ADC	Add byte or word with carry
INC	Increment byte or word by 1
AAA	ASCII adjust for addition
DAA	Decimal adjust for addition
Subtraction	
SUB	Subtract byte or word
SBB	Subtract byte or word with borrow
DEC	Decrement byte or word by 1
NEG	Negate byte or word
CMP	Compare byte or word
AAS	ASCII adjust for subtraction
DAS	Decimal adjust for subtraction
Multiplication	
MUL	Multiply byte or word unsigned
IMUL	Integer multiply byte or word
AAM	ASCII adjust for multiplication
Division	
DIV	Divide byte or word unsigned
IDIV	Integer divide byte or word
AAD	ASCII adjust for division
CBW	Convert byte to word
CWD	Convert word to double-word

Table 2-5. Arithmetic Interpretation of 8-Bit Numbers

Hex	Bit Pattern	Unsigned Binary	Signed Binary	Unpacked Decimal	Packed Decimal
07	00000111	7	+7	7	7
89	10001001	137	-119	invalid	89
C5	11000101	197	-59	invalid	invalid

2.2.1.3 Bit Manipulation Instructions

There are three groups of instructions for manipulating bits within bytes and words. These three groups are logical, shifts and rotates. Table 2-6 lists the bit manipulation instructions and their functions.

Table 2-6. Bit Manipulation Instructions

Logicals	
NOT	"Not" byte or word
AND	"And" byte or word
OR	"Inclusive or" byte or word
XOR	"Exclusive or" byte or word
TEST	"Test" byte or word
Shifts	
SHL/SAL	Shift logical/arithmetic left byte or word
SHR	Shift logical right byte or word
SAR	Shift arithmetic right byte or word
Rotates	
ROL	Rotate left byte or word
ROR	Rotate right byte or word
RCL	Rotate through carry left byte or word
RCR	Rotate through carry right byte or word

Logical instructions include the Boolean operators NOT, AND, OR and exclusive OR (XOR), as well as a TEST instruction. The TEST instruction sets the flags as a result of a Boolean AND operation but does not alter either of its operands.

Individual bits in bytes and words can be shifted either arithmetically or logically. Up to 32 shifts can be performed, according to the value of the count operand coded in the instruction. The count can be specified as an immediate value or as a variable in the CL register. This allows the shift count to be a supplied at execution time. Arithmetic shifts can be used to multiply and divide binary numbers by powers of two. Logical shifts can be used to isolate bits in bytes or words.

Individual bits in bytes and words can also be rotated. The processor does not discard the bits rotated out of an operand. The bits circle back to the other end of the operand. The number of bits to be rotated is taken from the count operand, which can specify either an immediate value or the CL register. The carry flag can act as an extension of the operand in two of the rotate instructions. This allows a bit to be isolated in the Carry Flag (CF) and then tested by a JC (jump if carry) or JNC (jump if not carry) instruction.

2.2.1.4 String Instructions

Five basic string operations process strings of bytes or words, one element (byte or word) at a time. Strings of up to 64 Kbytes can be manipulated with these instructions. Instructions are available to move, compare or scan for a value, as well as to move string elements to and from the accumulator. Table 2-7 lists the string instructions. These basic operations can be preceded by a one-byte prefix that causes the instruction to be repeated by the hardware, allowing long strings to be processed much faster than is possible with a software loop. The repetitions can be terminated by a variety of conditions. Repeated operations can be interrupted and resumed.

Table 2-7. String Instructions

REP	Repeat
REPE/REPZ	Repeat while equal/zero
REPNE/REPNZ	Repeat while not equal/not zero
MOVSB/MOVSX	Move byte string/word string
MOVS	Move byte or word string
INS	Input byte or word string
OUTS	Output byte or word string
CMPS	Compare byte or word string
SCAS	Scan byte or word string
LODS	Load byte or word string
STOS	Store byte or word string

String instructions operate similarly in many respects (see Table 2-8). A string instruction can have a source operand, a destination operand, or both. The hardware assumes that a source string resides in the current data segment. A segment prefix can override this assumption. A destination string must be in the current extra segment. The assembler does not use the operand names to address strings. Instead, the contents of the Source Index (SI) register are used as an offset to address the current element of the source string. The contents of the Destination Index (DI) register are taken as the offset of the current destination string element. These registers must be initialized to point to the source and destination strings before executing the string instructions. The LDS, LES and LEA instructions are useful in performing this function.

String instructions automatically update the SI register, the DI register, or both, before processing the next string element. The Direction Flag (DF) determines whether the index registers are auto-incremented (DF = 0) or auto-decremented (DF = 1). The processor adjusts the DI, SI, or both registers by one for byte strings or by two for word strings.

If a repeat prefix is used, the count register (CX) is decremented by one after each repetition of the string instruction. The CX register must be initialized to the number of repetitions before the string instruction is executed. If the CX register is 0, the string instruction is not executed and control goes to the following instruction.

Table 2-8. String Instruction Register and Flag Use

SI	Index (offset) for source string
DI	Index (offset) for destination string
CX	Repetition counter
AL/AX	Scan value Destination for LODS Source for STOS
DF	Direction Flag 0 = auto-increment SI, DI 1 = auto-decrement SI, DI
ZF	Scan/compare terminator

2.2.1.5 Program Transfer Instructions

The contents of the Code Segment (CS) and Instruction Pointer (IP) registers determine the instruction execution sequence in the 80C186 Modular Core family. The CS register contains the base address of the current code segment. The Instruction Pointer register points to the memory location of the next instruction to be fetched. In most operating conditions, the next instruction will already have been fetched and will be waiting in the CPU instruction queue. Program transfer instructions operate on the IP and CS registers. Changing the contents of these registers causes normal sequential operation to be altered. When a program transfer occurs, the queue no longer contains the correct instruction. The Bus Interface Unit obtains the next instruction from memory using the new IP and CS values. It then passes the instruction directly to the Execution Unit and begins refilling the queue from the new location.

The 80C186 Modular Core family offers four groups of program transfer instructions (see Table 2-9). These are unconditional transfers, conditional transfers, iteration control instructions and interrupt-related instructions.

Unconditional transfer instructions can transfer control either to a target instruction within the current code segment (intra-segment transfer) or to a different code segment (inter-segment transfer). The assembler terms an intra-segment transfer **SHORT** or **NEAR** and an inter-segment transfer **FAR**. The transfer is made unconditionally when the instruction is executed. **CALL**, **RET** and **JMP** are all unconditional transfers.

CALL is used to transfer the program to a procedure. A **CALL** can be **NEAR** or **FAR**. A **NEAR CALL** stacks only the Instruction Pointer, while a **FAR CALL** stacks both the Instruction Pointer and the Code Segment register. The **RET** instruction uses the information pushed onto the stack to determine where to return when the procedure finishes. Note that the **RET** and **CALL** instructions must be the same type. This can be a problem when the **CALL** and **RET** instructions are in separately assembled programs. The **JMP** instruction does not push any information onto the stack. A **JMP** instruction can be **NEAR** or **FAR**.

Conditional transfer instructions are jumps that may or may not transfer control, depending on the state of the CPU flags when the instruction is executed. Each conditional transfer instruction tests a different combination of flags for a condition (see Table 2-10). If the condition is logically **TRUE**, control is transferred to the target specified in the instruction. If the condition is **FALSE**, control passes to the instruction following the conditional jump. All conditional jumps are **SHORT**. The target must be in the current code segment within -128 to $+127$ bytes of the next instruction's first byte. For example, **JMP 00H** causes a jump to the first byte of the next instruction. Jumps are made by adding the relative displacement of the target to the Instruction Pointer. All conditional jumps are self-relative and are appropriate for position-independent routines.

Table 2-9. Program Transfer Instructions

Conditional Transfers	
JA/JNBE	Jump if above/not below nor equal
JAE/JNB	Jump if above or equal/not below
JB/JNAE	Jump if below/not above nor equal
JBE/JNA	Jump if below or equal/not above
JC	Jump if carry
JE/JZ	Jump if equal/zero
JG/JNLE	Jump if greater/not less nor equal
JGE/JNL	Jump if greater or equal/not less
JL/JNGE	Jump if less/not greater nor equal
JLE/JNG	Jump if less or equal/not greater
JNC	Jump if not carry
JNE/JNZ	Jump if not equal/not zero
JNO	Jump if not overflow
JNP/JPO	Jump if not parity/parity odd
JNS	Jump if not sign
JO	Jump if overflow
JP/JPE	Jump if parity/parity even
JS	Jump if sign
Unconditional Transfers	
CALL	Call procedure
RET	Return from procedure
JMP	Jump
Iteration Control	
LOOP	Loop
LOOPE/LOOPZ	Loop if equal/zero
LOOPNE/LOOPNZ	Loop if not equal/not zero
JCXZ	Jump if register CX=0
Interrupts	
INT	Interrupt
INTO	Interrupt if overflow
BOUND	Interrupt if out of array bounds
IRET	Interrupt return

Iteration control instructions can be used to regulate the repetition of software loops. These instructions use the CX register as a counter. Like the conditional transfers, the iteration control instructions are self-relative and can transfer only to targets that are within -128 to +127 bytes of themselves. They are SHORT transfers.

The interrupt instructions allow programs and external hardware devices to activate interrupt service routines. The effect of a software interrupt is similar to that of a hardware-initiated interrupt. The processor cannot execute an interrupt acknowledge bus cycle if the interrupt originates in software or with an NMI (Non-Maskable Interrupt).

Table 2-10. Interpretation of Conditional Transfers

Mnemonic	Condition Tested	“Jump if...”
JA/JNBE	(CF or ZF)=0	above/not below nor equal
JAE/JNB	CF=0	above or equal/not below
JB/JNAE	CF=1	below/not above nor equal
JBE/JNA	(CF or ZF)=1	below or equal/not above
JC	CF=1	carry
JE/JZ	ZF=1	equal/zero
JG/JNLE	((SF xor OF) or ZF)=0	greater/not less nor equal
JGE/JNL	(SF xor OF)=0	greater or equal/not less
JL/JNGE	(SF xor OF)=1	less/not greater nor equal
JLE/JNG	((SF xor OF) or ZF)=1	less or equal/not greater
JNC	CF=0	not carry
JNE/JNZ	ZF=0	not equal/not zero
JNO	OF=0	not overflow
JNP/JPO	PF=0	not parity/parity odd
JNS	SF=0	not sign
JO	OF=1	overflow
JP/JPE	PF=1	parity/parity equal
JS	SF=1	sign

NOTE: The terms *above* and *below* refer to the relationship of two unsigned values; *greater* and *less* refer to the relationship of two signed values.

2.2.1.6 Processor Control Instructions

Processor control instructions (see Table 2-11) allow programs to control various CPU functions. Seven of these instructions update flags, four of them are used to synchronize the microprocessor with external events, and the remaining instruction causes the CPU to do nothing. Except for flag operations, processor control instructions do not affect the flags.

Table 2-11. Processor Control Instructions

Flag Operations	
STC	Set Carry flag
CLC	Clear Carry flag
CMC	Complement Carry flag
STD	Set Direction flag
CLD	Clear Direction flag
STI	Set Interrupt Enable flag
CLI	Clear Interrupt Enable flag
External Synchronization	
HLT	Halt until interrupt or reset
WAIT	Wait for $\overline{\text{TEST}}$ pin active
ESC	Escape to external processor
LOCK	Lock bus during next instruction
No Operation	
NOP	No operation

2.2.2 Addressing Modes

The 80C186 Modular Core family members access instruction operands in several ways. Operands can be contained either in registers, in the instruction itself, in memory or at I/O ports. Addresses of memory and I/O port operands can be calculated in many ways. These addressing modes greatly extend the flexibility and convenience of the instruction set. The following paragraphs briefly describe register and immediate modes of operand addressing. A detailed description of the memory and I/O addressing modes is also provided.

2.2.2.1 Register and Immediate Operand Addressing Modes

Usually, the fastest, most compact operand addressing forms specify only register operands. This is because the register operand addresses are encoded in instructions in just a few bits and no bus cycles are run (the operation occurs within the CPU). Registers can serve as source operands, destination operands, or both.

Immediate operands are constant data contained in an instruction. Immediate data can be either 8 or 16 bits in length. Immediate operands are available directly from the instruction queue and can be accessed quickly. As with a register operand, no bus cycles need to be run to get an immediate operand. Immediate operands can be only source operands and must have a constant value.

2.2.2.2 Memory Addressing Modes

Although the Execution Unit has direct access to register and immediate operands, memory operands must be transferred to and from the CPU over the bus. When the Execution Unit needs to read or write a memory operand, it must pass an offset value to the Bus Interface Unit. The Bus Interface Unit adds the offset to the shifted contents of a segment register, producing a 20-bit physical address. One or more bus cycles are then run to access the operand.

The offset that the Execution Unit calculates for memory operand is called the operand's Effective Address (EA). This address is an unsigned 16-bit number that expresses the operand's distance, in bytes, from the beginning of the segment in which it resides. The Execution Unit can calculate the effective address in several ways. Information encoded in the second byte of the instruction tells the Execution Unit how to calculate the effective address of each memory operand. A compiler or assembler derives this information from the instruction written by the programmer. Assembly language programmers have access to all addressing modes.

The Execution Unit calculates the Effective Address by summing a displacement, the contents of a base register and the contents of an index register (see Figure 2-12). Any combination of these can be present in a given instruction. This allows a variety of memory addressing modes.

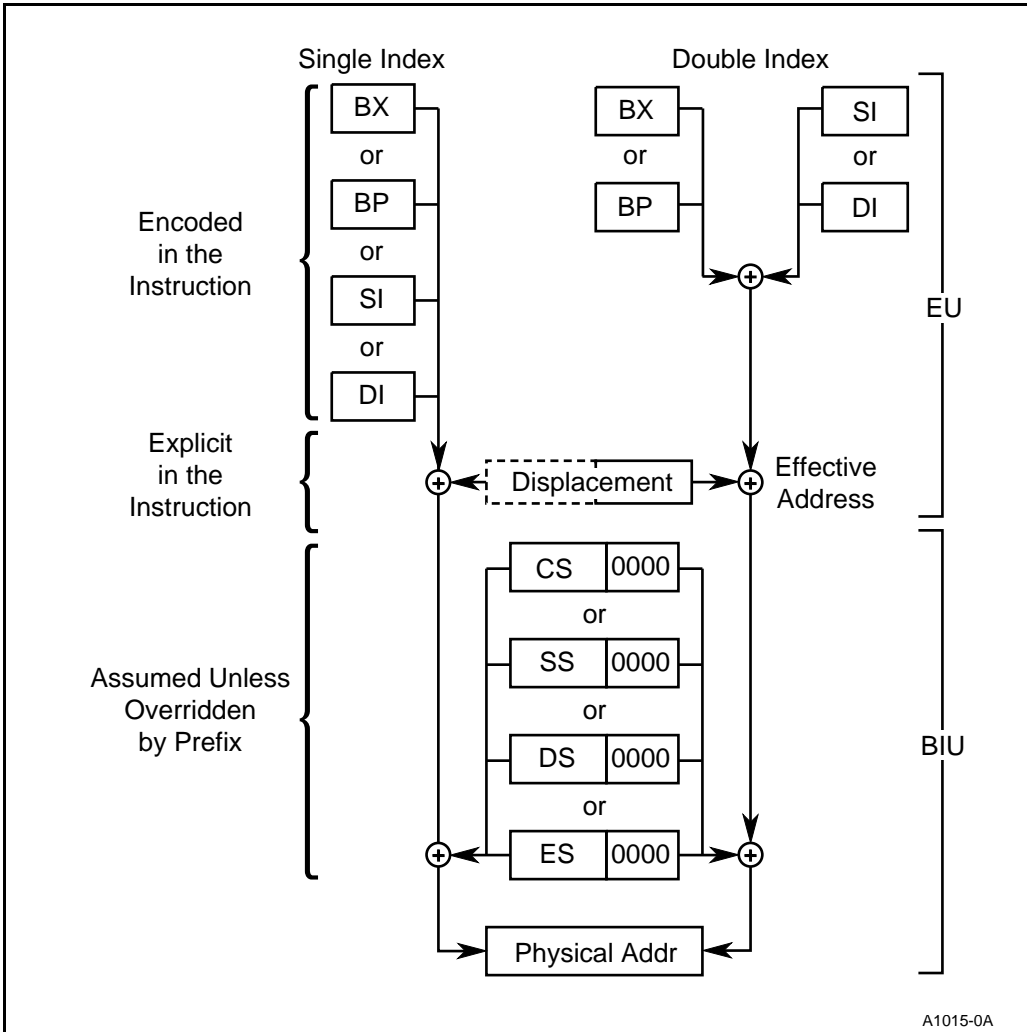

Figure 2-12. Memory Address Computation

The displacement is an 8- or 16-bit number contained in the instruction. The displacement generally is derived from the position of the operand's name (a variable or label) in the program. The programmer can modify this value or explicitly specify the displacement.

The BX or BP register can be specified as the base register for an effective address calculation. Similarly, either the SI or the DI register can be specified as the index register. The displacement value is a constant. The contents of the base and index registers can change during execution. This allows one instruction to access different memory locations depending upon the current values in the base or base and index registers. The default base register for effective address calculations with the BP register is SS, although DS or ES can be specified.

Direct addressing is the simplest memory addressing mode (see Figure 2-13). No registers are involved, and the effective address is taken directly from the displacement of the instruction. Programmers typically use direct addressing to access scalar variables.

With register indirect addressing, the effective address of a memory operand can be taken directly from one of the base or index registers (see Figure 2-14). One instruction can operate on various memory locations if the base or index register is updated accordingly. Any 16-bit general register can be used for register indirect addressing with the JMP or CALL instructions.

In based addressing, the effective address is the sum of a displacement value and the contents of the BX or BP register (see Figure 2-15). Specifying the BP register as a base register directs the Bus Interface Unit to obtain the operand from the current stack segment (unless a segment override prefix is present). This makes based addressing with the BP register a convenient way to access stack data.

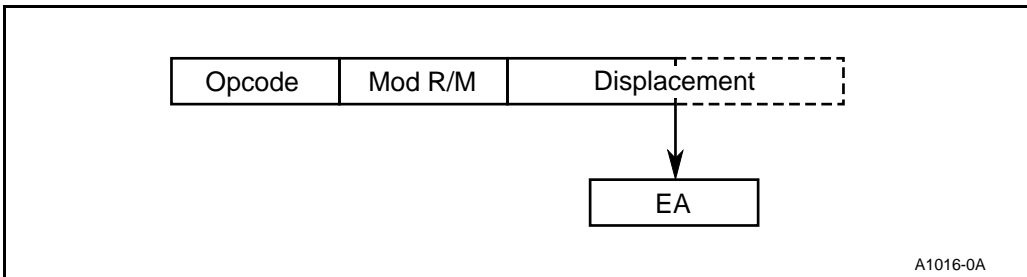

A1016-0A

Figure 2-13. Direct Addressing

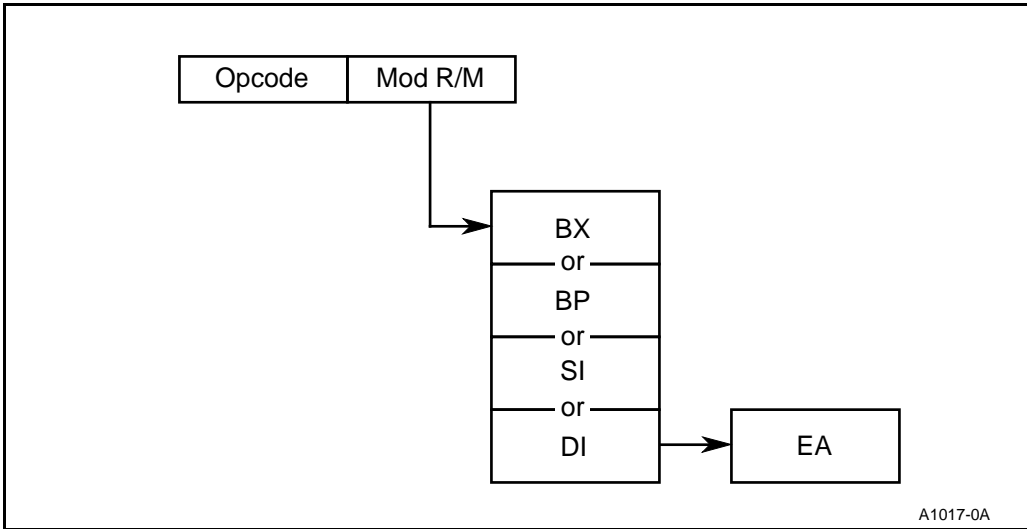

Figure 2-14. Register Indirect Addressing

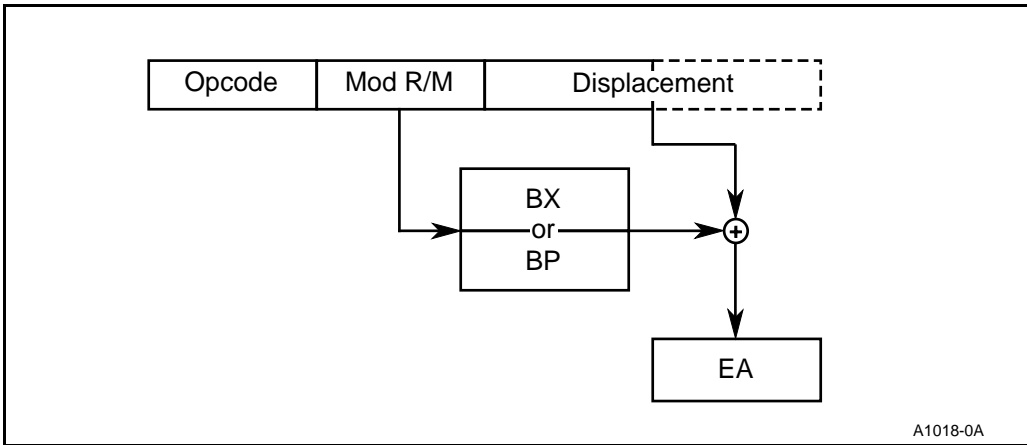
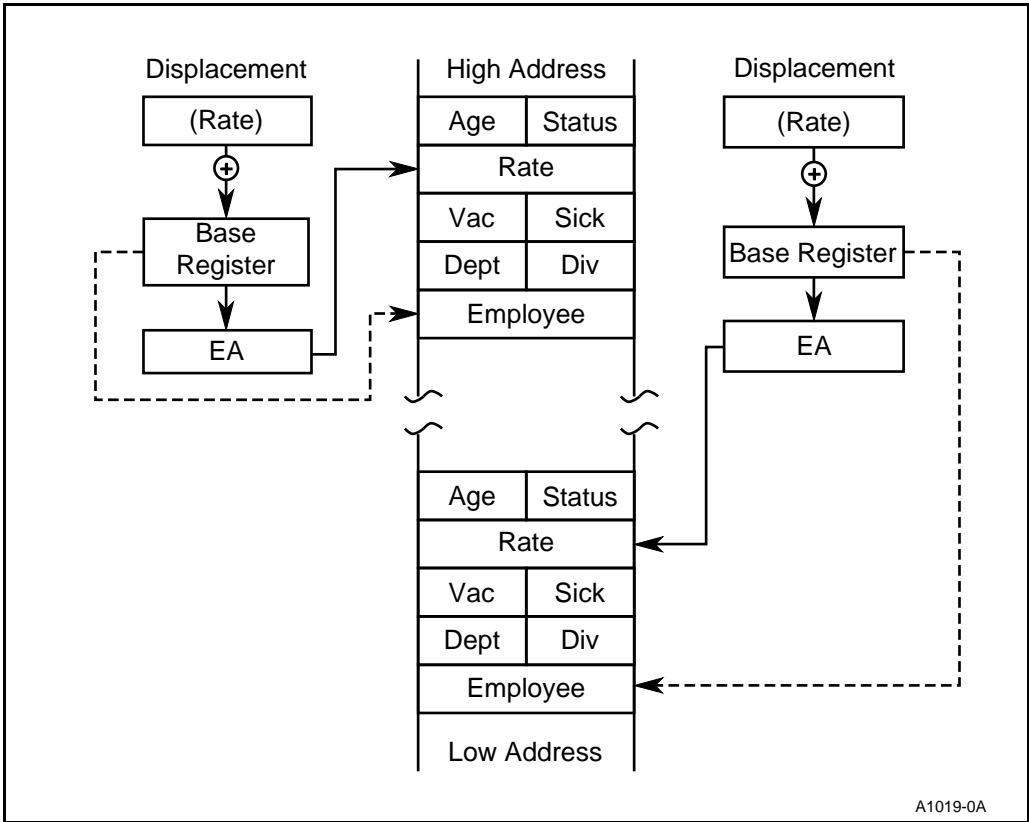

Figure 2-15. Based Addressing

Based addressing provides a simple way to address data structures that may be located in different places in memory (see Figure 2-16). A base register can be pointed at the structure. Elements of the structure can then be addressed by their displacements. Different copies of the same structure can be accessed by simply changing the base register.



A1019-0A

Figure 2-16. Accessing a Structure with Based Addressing

With indexed addressing, the effective address is calculated by summing a displacement and the contents of an index register (SI or DI, see Figure 2-17). Indexed addressing is often used to access elements in an array (see Figure 2-18). The displacement locates the beginning of the array, and the value of the index register selects one element. If the index register contains 0000H, the processor selects the first element. Since all array elements are the same length, simple arithmetic on the register can select any element.

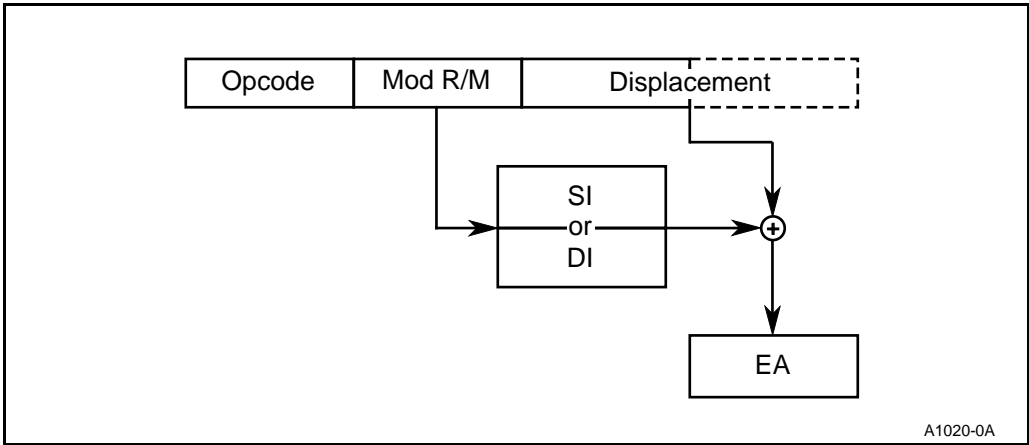

A1020-0A

Figure 2-17. Indexed Addressing

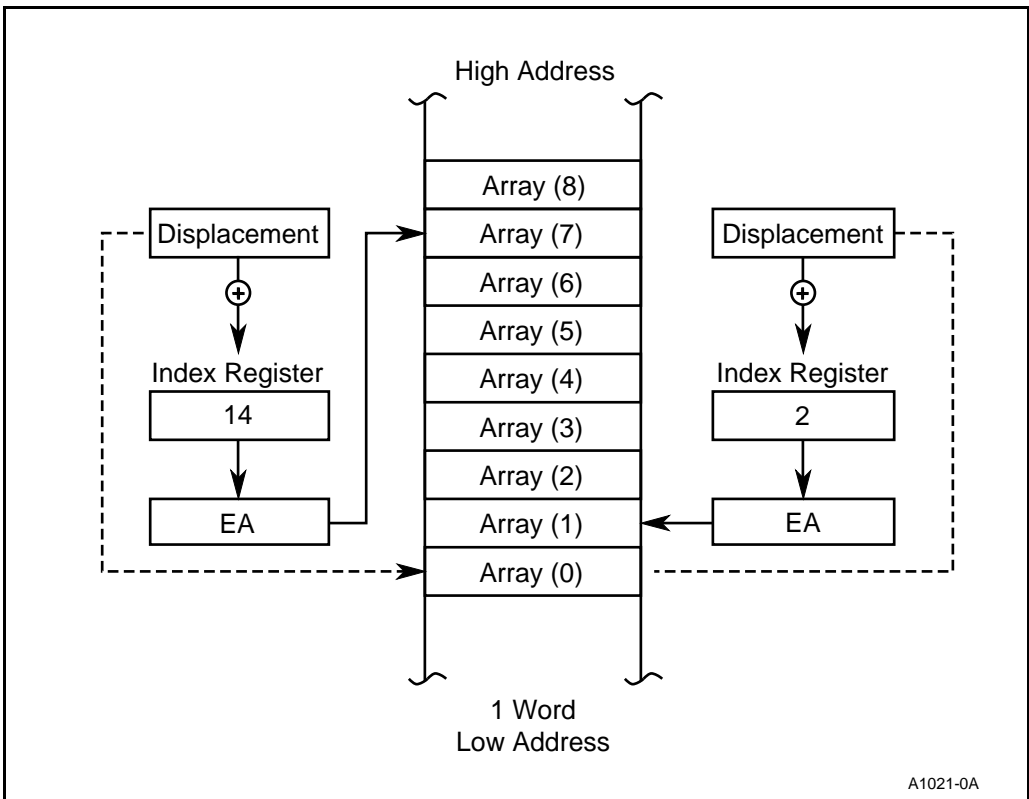

A1021-0A

Figure 2-18. Accessing an Array with Indexed Addressing

Based index addressing generates an effective address that is the sum of a base register, an index register and a displacement (see Figure 2-19). The two address components can be determined at execution time, making this a very flexible addressing mode.

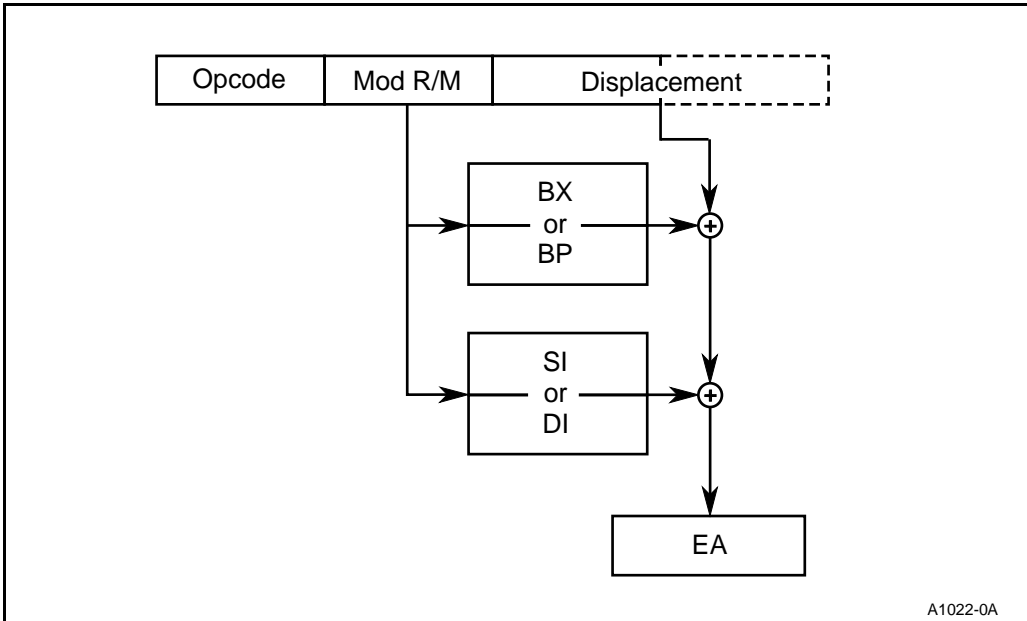

Figure 2-19. Based Index Addressing

Based index addressing provides a convenient way for a procedure to address an array located on a stack (see Figure 2-20). The BP register can contain the offset of a reference point on the stack. This is typically the top of the stack after the procedure has saved registers and allocated local storage. The offset of the beginning of the array from the reference point can be expressed by a displacement value. The index register can be used to access individual array elements. Arrays contained in structures and matrices (two-dimensional arrays) can also be accessed with based indexed addressing.

String instructions do not use normal memory addressing modes to access operands. Instead, the index registers are used implicitly (see Figure 2-21). When a string instruction executes, the SI register must point to the first byte or word of the source string, and the DI register must point to the first byte or word of the destination string. In a repeated string operation, the CPU will automatically adjust the SI and DI registers to obtain subsequent bytes or words. For string instructions, the DS register is the default segment register for the SI register and the ES register is the default segment register for the DI register. This allows string instructions to operate on data located anywhere within the 1 Mbyte address space.

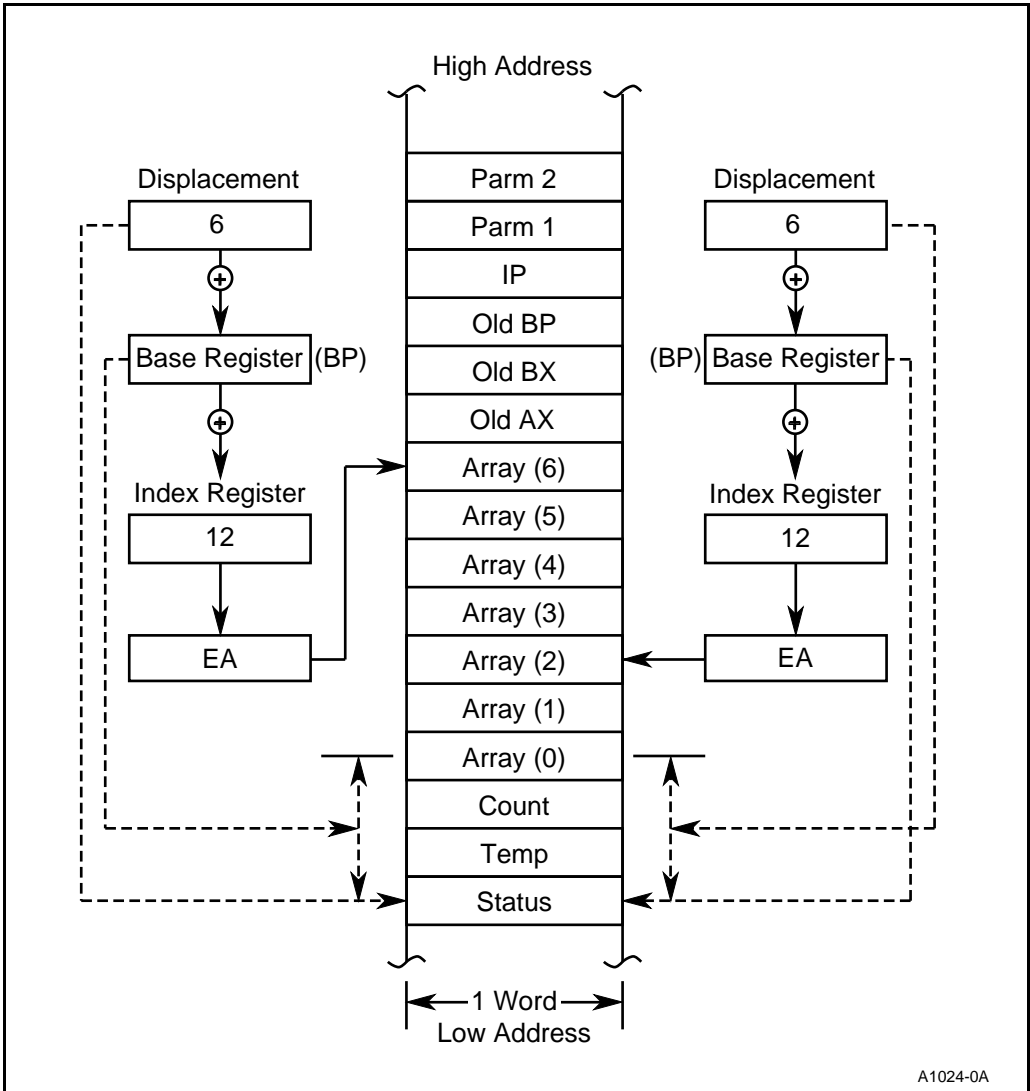

Figure 2-20. Accessing a Stacked Array with Based Index Addressing

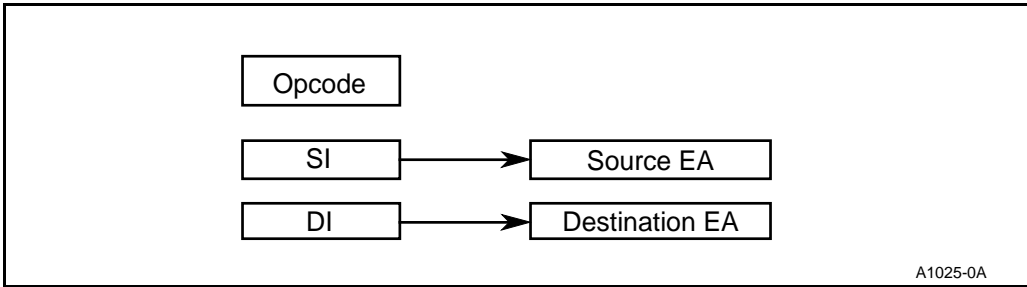

Figure 2-21. String Operand

2.2.2.3 I/O Port Addressing

Any memory operand addressing modes can be used to access an I/O port if the port is memory-mapped. String instructions can also be used to transfer data to memory-mapped ports with an appropriate hardware interface.

Two addressing modes can be used to access ports located in the I/O space (see Figure 2-22). For direct I/O port addressing, the port number is an 8-bit immediate operand. This allows fixed access to ports numbered 0 to 255. Indirect I/O port addressing is similar to register indirect addressing of memory operands. The DX register contains the port number, which can range from 0 to 65,535. Adjusting the contents of the DX register allows one instruction to access any port in the I/O space. A group of adjacent ports can be accessed using a simple software loop that adjusts the value of the DX register.

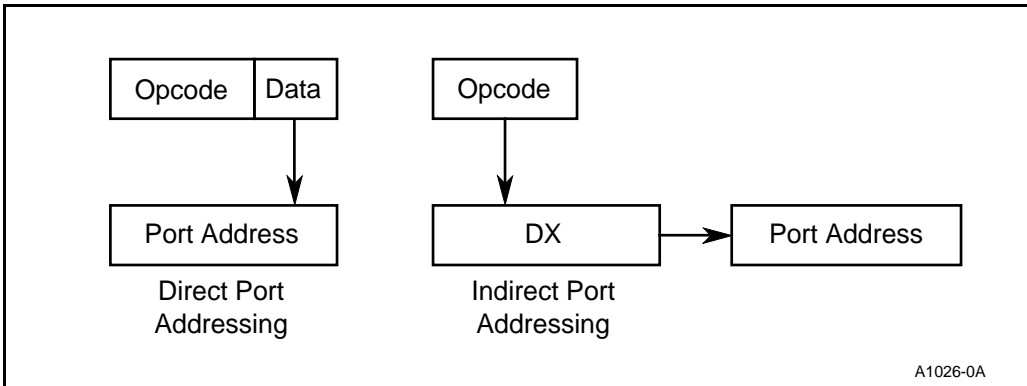

Figure 2-22. I/O Port Addressing

2.2.2.4 Data Types Used in the 80C186 Modular Core Family

The 80C186 Modular Core family supports the data types described in Table 2-12 and illustrated in Figure 2-23. In general, individual data elements must fit within defined segment limits.

Table 2-12. Supported Data Types

Type	Description
Integer	<p>A signed 8- or 16-bit binary numeric value (signed byte or word). All operations assume a 2's complement representation.</p> <p>The 80C187 numerics processor extension, when added to an 80C186 Modular Core system, directly supports signed 32- and 64-bit integers (signed double-words and quad-words). The 80C188 Modular Core does not support the 80C187.</p>
Ordinal	<p>An unsigned 8- or 16-bit binary numeric value (unsigned byte or word).</p>
BCD	<p>A byte (unpacked) representation of a single decimal digit (0-9).</p>
ASCII	<p>A byte representation of alphanumeric and control characters using the ASCII standard.</p>
Packed BCD	<p>A byte (packed) representation of two decimal digits (0-9). One digit is stored in each nibble (4 bits) of the byte.</p>
String	<p>A contiguous sequence of bytes or words. A string can contain from 1 byte to 64 Kbytes.</p>
Pointer	<p>A 16- or 32-bit quantity. A 16-bit pointer consists of a 16-bit offset component; a 32-bit pointer consists of the combination of a 16-bit base component (selector) plus a 16-bit offset component.</p>
Floating Point	<p>A signed 32-, 64-, or 80-bit real number representation.</p> <p>The 80C187 numerics processor extension, when added to an 80C186 Modular Core system, directly supports floating point operands. The 80C188 Modular Core does not support the 80C187.</p>

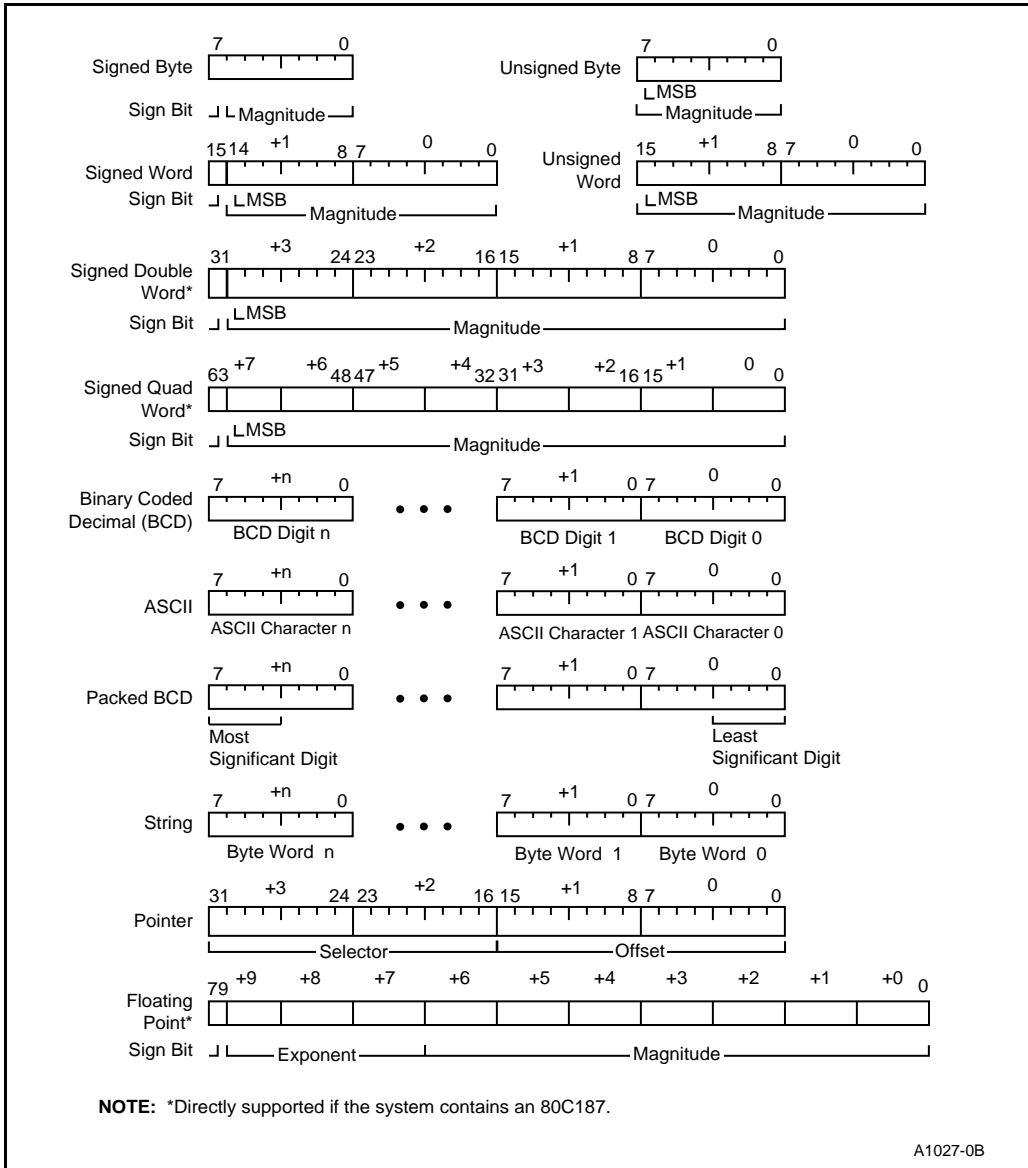

Figure 2-23. 80C186 Modular Core Family Supported Data Types

2.3 INTERRUPTS AND EXCEPTION HANDLING

Interrupts and exceptions alter program execution in response to an external event or an error condition. An interrupt handles asynchronous external events, for example an NMI. Exceptions result directly from the execution of an instruction, usually an instruction fault. The user can cause a software interrupt by executing an “INT*n*” instruction. The CPU processes software interrupts in the same way that it handles exceptions.

The 80C186 Modular Core responds to interrupts and exceptions in the same way for all devices within the 80C186 Modular Core family. However, devices within the family may have different Interrupt Control Units. The Interrupt Control Unit handles all external interrupt sources and presents them to the 80C186 Modular Core via one maskable interrupt request (see Figure 2-24). This discussion covers only those areas of interrupts and exceptions that are common to the 80C186 Modular Core family. The Interrupt Control Unit is proliferation-dependent; see Chapter 8, “Interrupt Control Unit,” for additional information.

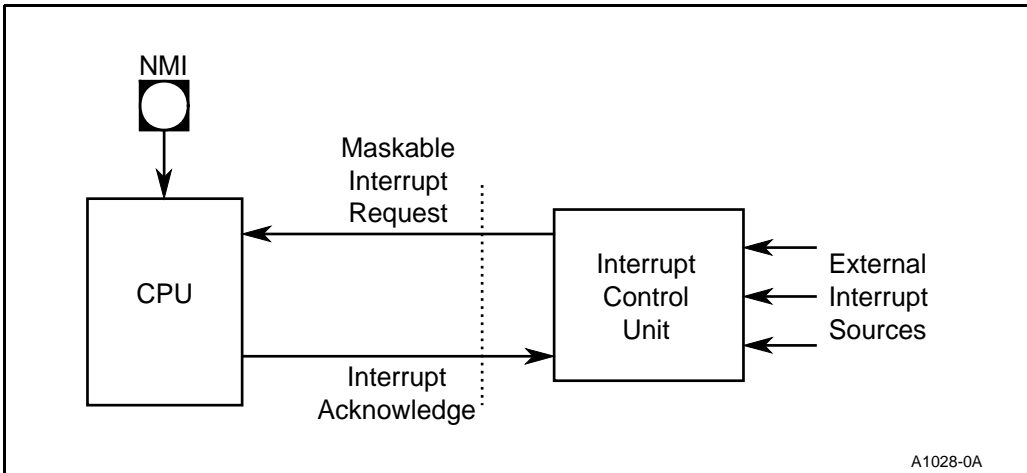

Figure 2-24. Interrupt Control Unit

2.3.1 Interrupt/Exception Processing

The 80C186 Modular Core can service up to 256 different interrupts and exceptions. A 256-entry Interrupt Vector Table (Figure 2-25) contains the pointers to interrupt service routines. Each entry consists of four bytes, which contain the Code Segment (CS) and Instruction Pointer (IP) of the first instruction in the interrupt service routine. Each interrupt or exception is given a type number, 0 through 255, corresponding to its position in the Interrupt Vector Table. Note that interrupt types 0–31 are reserved for Intel and should **not** be used by an application program.

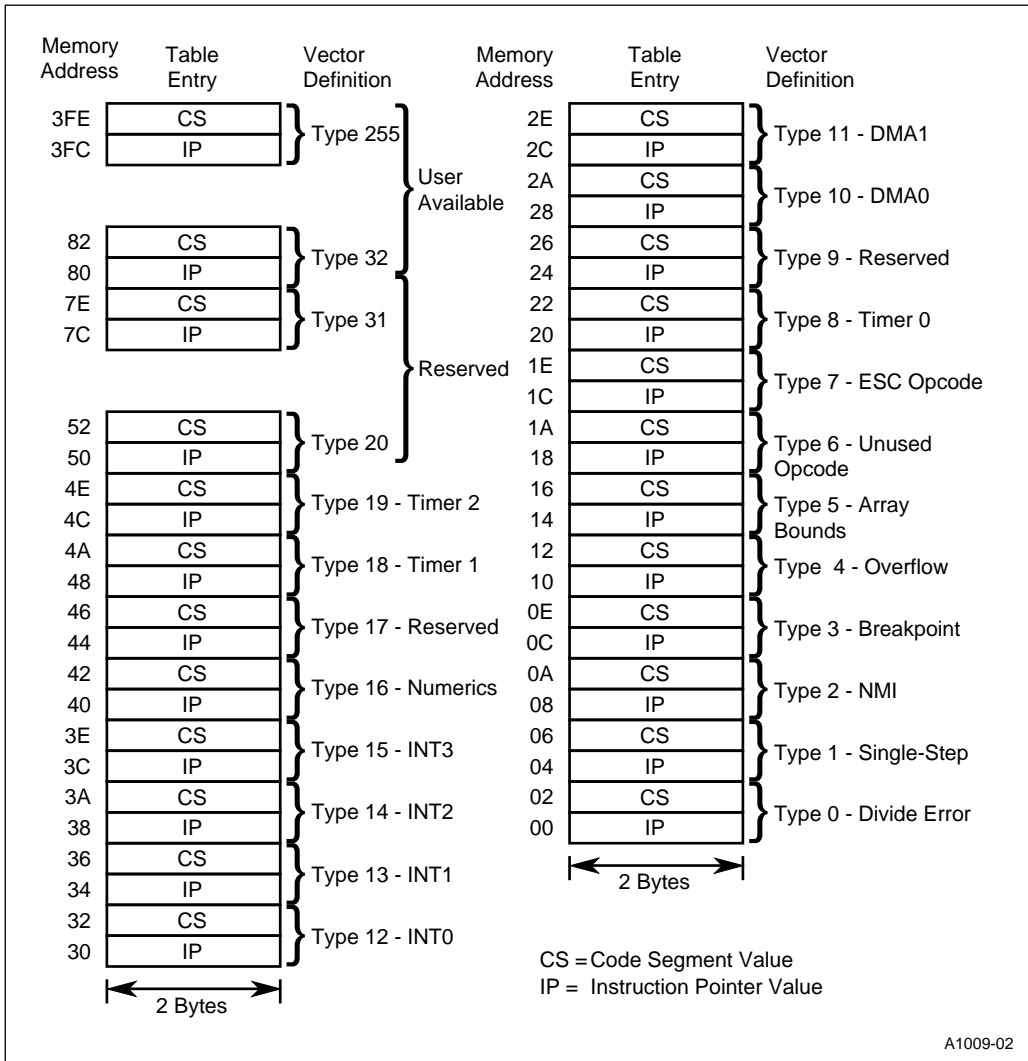

Figure 2-25. Interrupt Vector Table

When an interrupt is acknowledged, a common event sequence (Figure 2-26) allows the processor to execute the interrupt service routine.

1. The processor saves a partial machine status by pushing the Processor Status Word onto the stack.

2. The Trap Flag bit and Interrupt Enable bit are cleared in the Processor Status Word. This prevents maskable interrupts or single step exceptions from interrupting the processor during the interrupt service routine.
3. The current CS and IP are pushed onto the stack.
4. The CPU fetches the new CS and IP for the interrupt vector routine from the Interrupt Vector Table and begins executing from that point.

The CPU is now executing the interrupt service routine. The programmer must save (usually by pushing onto the stack) all registers used in the interrupt service routine; otherwise, their contents will be lost. To allow nesting of maskable interrupts, the programmer must set the Interrupt Enable bit in the Processor Status Word.

When exiting an interrupt service routine, the programmer must restore (usually by popping off the stack) the saved registers and execute an IRET instruction, which performs the following steps.

1. Loads the return CS and IP by popping them off the stack.
2. Pops and restores the old Processor Status Word from the stack.

The CPU now executes from the point at which the interrupt or exception occurred.

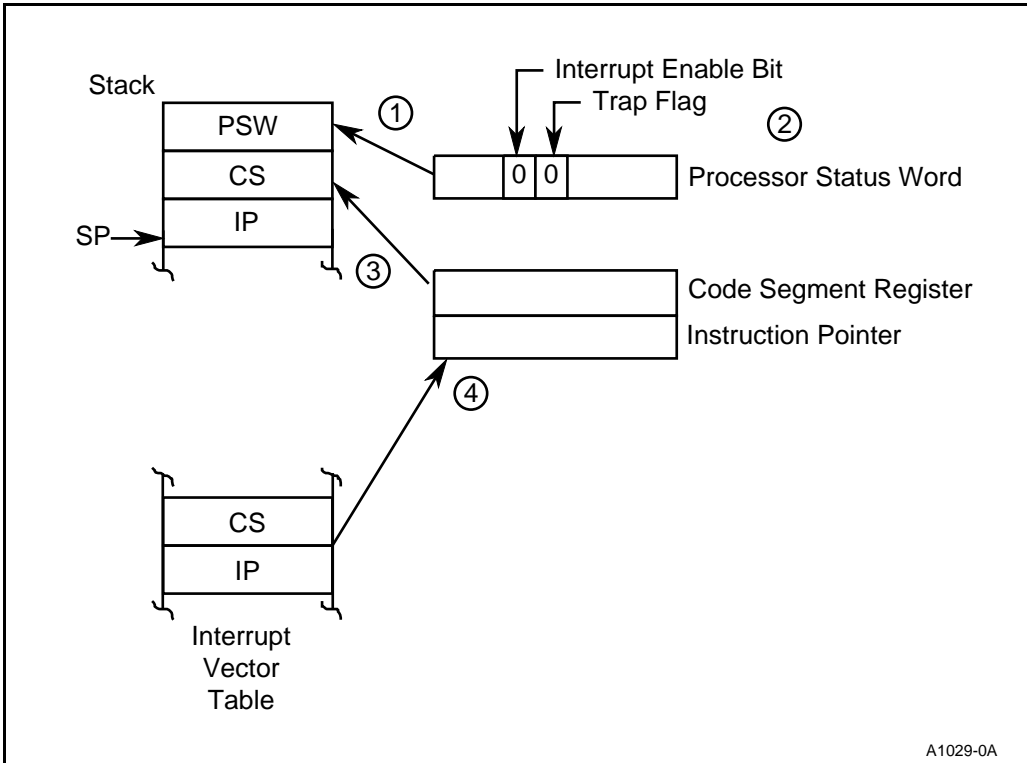

Figure 2-26. Interrupt Sequence

2.3.1.1 Non-Maskable Interrupts

The Non-Maskable Interrupt (NMI) is the highest priority interrupt. It is usually reserved for a catastrophic event such as impending power failure. An NMI cannot be prevented (or masked) by software. When the NMI input is asserted, the interrupt processing sequence begins after execution of the current instruction completes (see “Interrupt Latency” on page 2-45). The CPU automatically generates a type 2 interrupt vector.

The NMI input is asynchronous. Setup and hold times are given only to guarantee recognition on a specific clock edge. To be recognized, NMI must be asserted for at least one CLKOUT period and meet the correct setup and hold times. NMI is edge-triggered and level-latched. Multiple NMI requests cause multiple NMI service routines to be executed. NMI can be nested in this manner an infinite number of times.

2.3.1.2 Maskable Interrupts

Maskable interrupts are the most common way to service external hardware interrupts. Software can globally enable or disable maskable interrupts. This is done by setting or clearing the Interrupt Enable bit in the Processor Status Word.

The Interrupt Control Unit processes the multiple sources of maskable interrupts and presents them to the core via a single maskable interrupt input. The Interrupt Control Unit provides the interrupt vector type to the 80C186 Modular Core. The Interrupt Control Unit differs among members of the 80C186 Modular Core family; see Chapter 8, “Interrupt Control Unit,” for information.

2.3.1.3 Exceptions

Exceptions occur when an unusual condition prevents further instruction processing until the exception is corrected. The CPU handles software interrupts and exceptions in the same way. The interrupt type for an exception is either predefined or supplied by the instruction.

Exceptions are classified as either faults or traps, depending on when the exception is detected and whether the instruction that caused the exception can be restarted. Faults are detected and serviced **before** the faulting instruction can be executed. The return address pushed onto the stack in the interrupt processing instruction points to the beginning of the faulting instruction. This allows the instruction to be restarted. Traps are detected and serviced immediately **after** the instruction that caused the trap. The return address pushed onto the stack during the interrupt processing points to the instruction following the trapping instruction.

Divide Error — Type 0

A Divide Error trap is invoked when the quotient of an attempted division exceeds the maximum value of the destination. A divide-by-zero is a common example.

Single Step — Type 1

The Single Step trap occurs after the CPU executes one instruction with the Trap Flag (TF) bit set in the Processor Status Word. This allows programs to execute one instruction at a time. Interrupts are not generated after prefix instructions (e.g., REP), after instructions that modify segment registers (e.g., POP DS) or after the WAIT instruction. Vectoring to the single-step interrupt service routine clears the Trap Flag bit. An IRET instruction in the interrupt service routine restores the Trap Flag bit to logic “1” and transfers control to the next instruction to be single-stepped.

Breakpoint Interrupt — Type 3

The Breakpoint Interrupt is a single-byte version of the INT instruction. It is commonly used by software debuggers to set breakpoints in RAM. Because the instruction is only one byte long, it can substitute for any instruction.

Interrupt on Overflow — Type 4

The Interrupt on Overflow trap occurs if the Overflow Flag (OF) bit is set in the Processor Status Word and the INTO instruction is executed. Interrupt on Overflow is a common method for handling arithmetic overflows conditionally.

Array Bounds Check — Type 5

An Array Bounds trap occurs when the array index is outside the array bounds during execution of the BOUND instruction (see Appendix A, “80C186 Instruction Set Additions and Extensions”).

Invalid Opcode — Type 6

Execution of an undefined opcode causes an Invalid Opcode trap.

Escape Opcode — Type 7

The Escape Opcode fault is used for floating point emulation. With 80C186 Modular Core family members, this fault is enabled by setting the Escape Trap (ET) bit in the Relocation Register (see Chapter 4, “Peripheral Control Block”). When a floating point instruction is executed with the Escape Trap bit set, the Escape Opcode fault occurs, and the Escape Opcode service routine emulates the floating point instruction. If the Escape Trap bit is cleared, the CPU sends the floating point instruction to an external 80C187.

80C188 Modular Core Family members do not support the 80C187 interface and always generate the Escape Opcode Fault. The 80C186EA will generate the Escape Opcode Fault regardless of the state of the Escape Trap bit unless it is in Numerics Mode.

Numerics Coprocessor Fault — Type 16

The Numerics Coprocessor fault is caused by an external 80C187 numerics coprocessor. The 80C187 reports the exception by asserting the **ERROR** pin. The 80C186 Modular Core checks the **ERROR** pin only when executing a numerics instruction. A Numerics Coprocessor Fault indicates that the **previous** numerics instruction caused the exception. The 80C187 saves the address of the floating point instruction that caused the exception. The return address pushed onto the stack during the interrupt processing points to the numerics instruction that detected the exception. This way, the last numerics instruction can be restarted.

2.3.2 Software Interrupts

A Software Interrupt is caused by executing an “INT n ” instruction. The n parameter corresponds to the specific interrupt type to be executed. The interrupt type can be any number between 0 and 255. If the n parameter corresponds to an interrupt type associated with a hardware interrupt (NMI, Timers), the vectors are fetched and the routine is executed, but the corresponding bits in the Interrupt Status register **are not altered**.

The CPU processes software interrupts and exceptions in the same way. Software interrupts, exceptions and traps cannot be masked.

2.3.3 Interrupt Latency

Interrupt latency is the amount of time it takes for the CPU to recognize the existence of an interrupt. The CPU generally recognizes interrupts only between instructions or on instruction boundaries. Therefore, the current instruction must finish executing before an interrupt can be recognized.

The worst-case 80C186 instruction execution time is an integer divide instruction with segment override prefix. The instruction takes 69 clocks, assuming an 80C186 Modular Core family member and a zero wait-state external bus. The execution time for an 80C188 Modular Core family member may be longer, depending on the queue.

This is one factor in determining interrupt latency. In addition, the following are also factors in determining maximum latency:

1. The CPU does not recognize the Maskable Interrupt unless the Interrupt Enable bit is set.
2. The CPU does not recognize interrupts during HOLD.
3. Once communication is completely established with an 80C187, the CPU does not recognize interrupts until the numerics instruction is finished.

The CPU can recognize interrupts only on valid instruction boundaries. A valid instruction boundary usually occurs when the current instruction finishes. The following is a list of exceptions:

1. MOVs and POPs referencing a segment register delay the servicing of interrupts until after the following instruction. The delay allows a 32-bit load to the SS and SP without an interrupt occurring between the two loads.
2. The CPU allows interrupts between repeated string instructions. If multiple prefixes precede a string instruction and the instruction is interrupted, only the one prefix preceding the string primitive is restored.
3. The CPU can be interrupted during a WAIT instruction. The CPU will return to the WAIT instruction.

2.3.4 Interrupt Response Time

Interrupt response time is the time from the CPU recognizing an interrupt until the first instruction in the service routine is executed. Interrupt response time is less for interrupts or exceptions which supply their own vector type. The maskable interrupt has a longer response time because the vector type must be supplied by the Interrupt Control Unit (see Chapter 8, “Interrupt Control Unit”).

Figure 2-27 shows the events that dictate interrupt response time for the interrupts that supply their type. Note that an on-chip bus master, such as the DRAM Refresh Unit, can make use of idle bus cycles. This can increase interrupt response time.

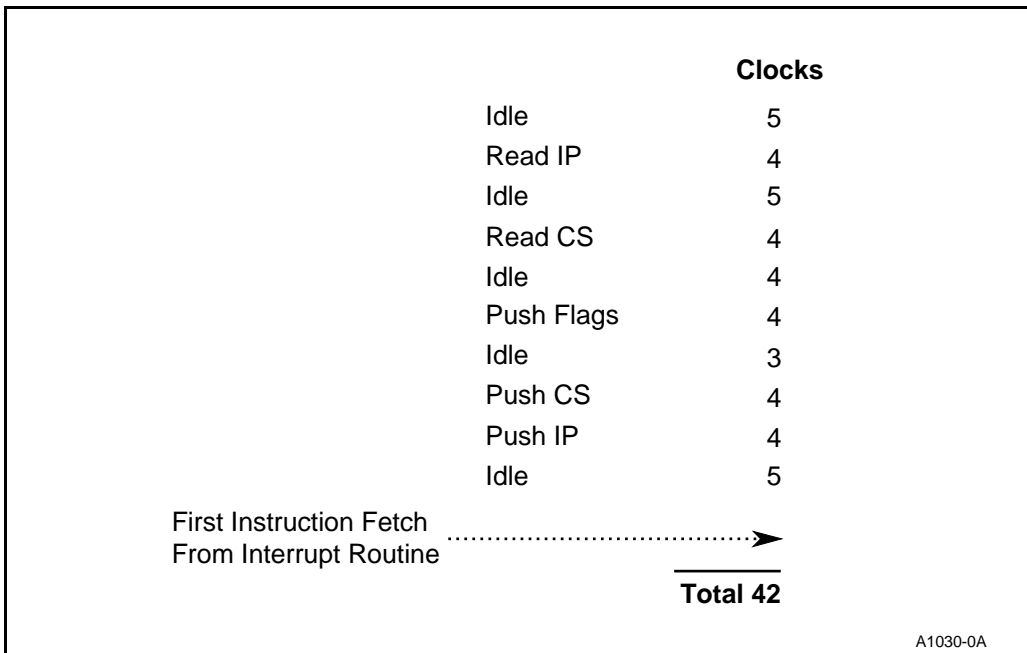

Figure 2-27. Interrupt Response Factors

2.3.5 Interrupt and Exception Priority

Interrupts can be recognized only on valid instruction boundaries. If an NMI and a maskable interrupt are both recognized on the same instruction boundary, NMI has precedence. The maskable interrupt will not be recognized until the Interrupt Enable bit is set and it is the highest priority.

Only the single step exception can occur concurrently with another exception. At most, two exceptions can occur at the same instruction boundary and one of those exceptions must be the single step. Single step is a special case; it is discussed on page 2-48. Ignoring single step (for now), only one exception can occur at any given instruction boundary.

An exception has priority over both NMI and the maskable interrupt. However, a pending NMI can interrupt the CPU at any valid instruction boundary. Therefore, NMI can interrupt an exception service routine. If an exception and NMI occur simultaneously, the exception vector is taken, then is followed immediately by the NMI vector (see Figure 2-28). While the exception has higher priority at the instruction boundary, the NMI interrupt service routine is executed first.

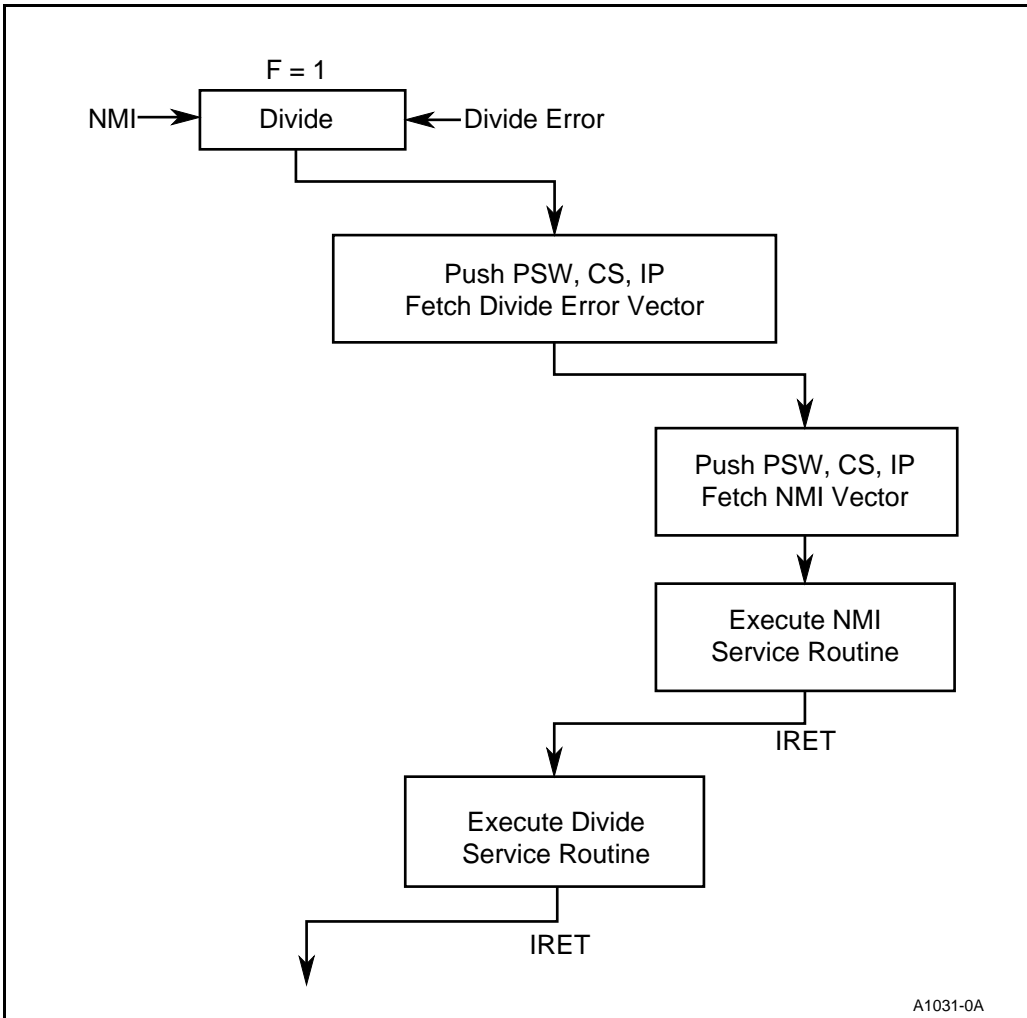

Figure 2-28. Simultaneous NMI and Exception

Single step priority is a special case. If an interrupt (NMI or maskable) occurs at the same instruction boundary as a single step, the interrupt vector is taken first, then is followed immediately by the single step vector. However, the single step service routine is executed before the interrupt service routine (see Figure 2-29). If the single step service routine re-enables single step by executing the IRET, the interrupt service routine will also be single stepped. This can severely limit the real-time response of the CPU to an interrupt.

To prevent the single-step routine from executing before a maskable interrupt, disable interrupts while single stepping an instruction, then enable interrupts in the single step service routine. The maskable interrupt is serviced from within the single step service routine and that interrupt service routine is not single-stepped. To prevent single stepping before an NMI, the single-step service routine must compare the return address on the stack to the NMI vector. If they are the same, return to the NMI service routine immediately without executing the single step service routine.

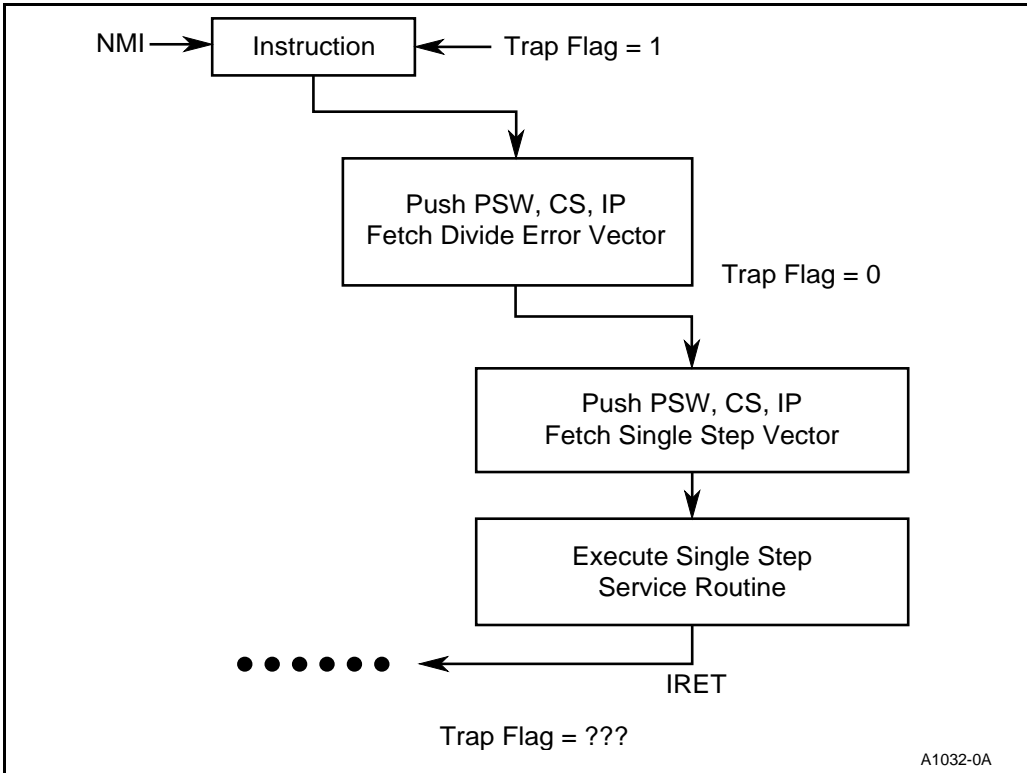

Figure 2-29. Simultaneous NMI and Single Step Interrupts

The most complicated case is when an NMI, a maskable interrupt, a single step and another exception are pending on the same instruction boundary. Figure 2-30 shows how this case is prioritized by the CPU. Note that if the single-step routine sets the Trap Flag (TF) bit before executing the IRET instruction, the NMI routine will also be single stepped.

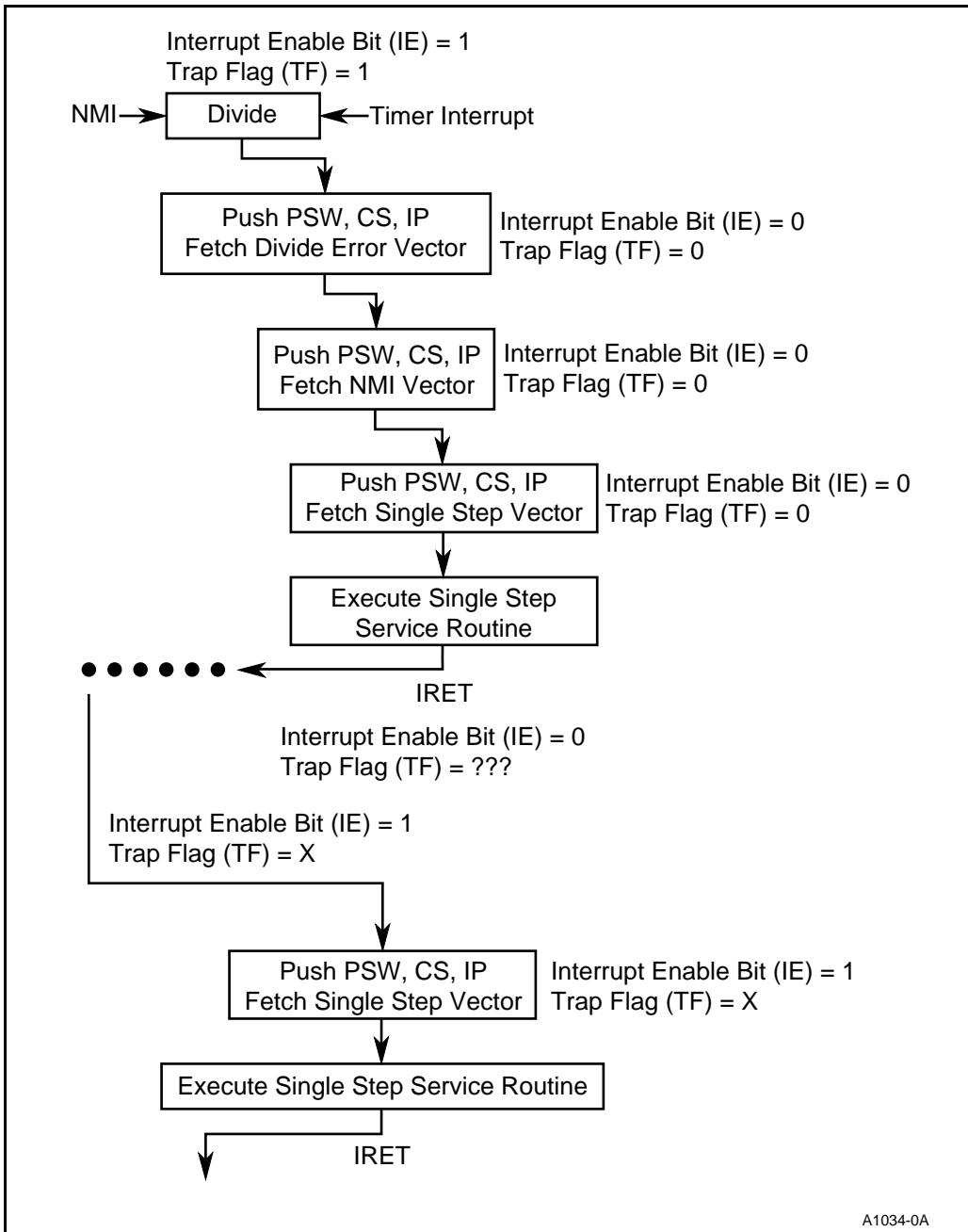

Figure 2-30. Simultaneous NMI, Single Step and Maskable Interrupt



3

Bus Interface Unit



CHAPTER 3

BUS INTERFACE UNIT

The Bus Interface Unit (BIU) generates bus cycles that prefetch instructions from memory, pass data to and from the execution unit, and pass data to and from the integrated peripheral units.

The BIU drives address, data, status and control information to define a bus cycle. The start of a bus cycle presents the address of a memory or I/O location and status information defining the type of bus cycle. Read or write control signals follow the address and define the direction of data flow. A read cycle requires data to flow from the selected memory or I/O device to the BIU. In a write cycle, the data flows from the BIU to the selected memory or I/O device. Upon termination of the bus cycle, the BIU latches read data or removes write data.

3.1 MULTIPLEXED ADDRESS AND DATA BUS

The BIU has a combined address and data bus, commonly referred to as a time-multiplexed bus. Time multiplexing address and data information makes the most efficient use of device package pins. A system with address latching provided within the memory and I/O devices can directly connect to the address/data bus (or *local bus*). The local bus can be demultiplexed with a single set of address latches to provide non-multiplexed address and data information to the system.

3.2 ADDRESS AND DATA BUS CONCEPTS

The programmer views the memory or I/O address space as a sequence of bytes. Memory space consists of 1 Mbyte, while I/O space consists of 64 Kbytes. Any byte can contain an 8-bit data element, and any two consecutive bytes can contain a 16-bit data element (identified as a word). The discussions in this section apply to both memory and I/O bus cycles. For brevity, memory bus cycles are used for examples and illustration.

3.2.1 16-Bit Data Bus

The memory address space on a 16-bit data bus is physically implemented by dividing the address space into two banks of up to 512 Kbytes each (see Figure 3-1). One bank connects to the lower half of the data bus and contains even-addressed bytes ($A_0=0$). The other bank connects to the upper half of the data bus and contains odd-addressed bytes ($A_0=1$). Address lines $A_{19:1}$ select a specific byte within each bank. A_0 and Byte High Enable (\overline{BHE}) determine whether one bank or both banks participate in the data transfer.

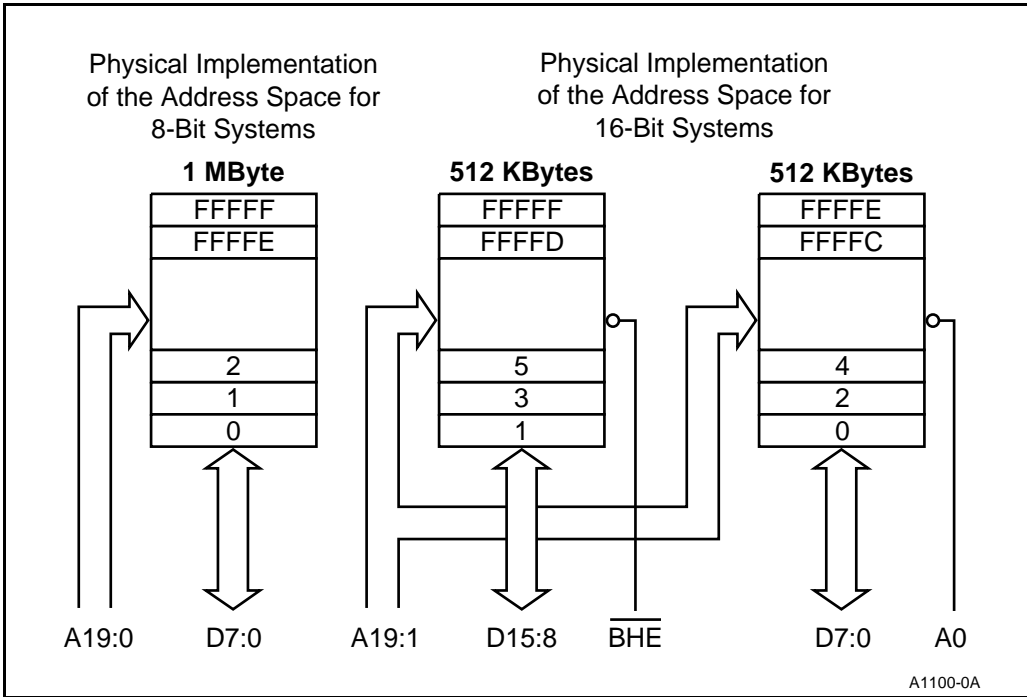

Figure 3-1. Physical Data Bus Models

Byte transfers to even addresses transfer information over the lower half of the data bus (see Figure 3-2). A0 low enables the lower bank, while $\overline{\text{BHE}}$ high disables the upper bank. The data value from the upper bank is ignored during a bus read cycle. $\overline{\text{BHE}}$ high prevents a write operation from destroying data in the upper bank.

Byte transfers to odd addresses transfer information over the upper half of the data bus (see Figure 3-2). $\overline{\text{BHE}}$ low enables the upper bank, while A0 high disables the lower bank. The data value from the lower bank is ignored during a bus read cycle. A0 high prevents a write operation from destroying data in the lower bank.

To access even-addressed 16-bit words (two consecutive bytes with the least-significant byte at an even address), information is transferred over both halves of the data bus (see Figure 3-3). A19:1 select the appropriate byte within each bank. A0 and $\overline{\text{BHE}}$ drive low to enable both banks simultaneously.

Odd-addressed word accesses require the BIU to split the transfer into two byte operations (see Figure 3-4). The first operation transfers data over the upper half of the bus, while the second operation transfers data over the lower half of the bus. The BIU automatically executes the two-byte sequence whenever an odd-addressed word access is performed.

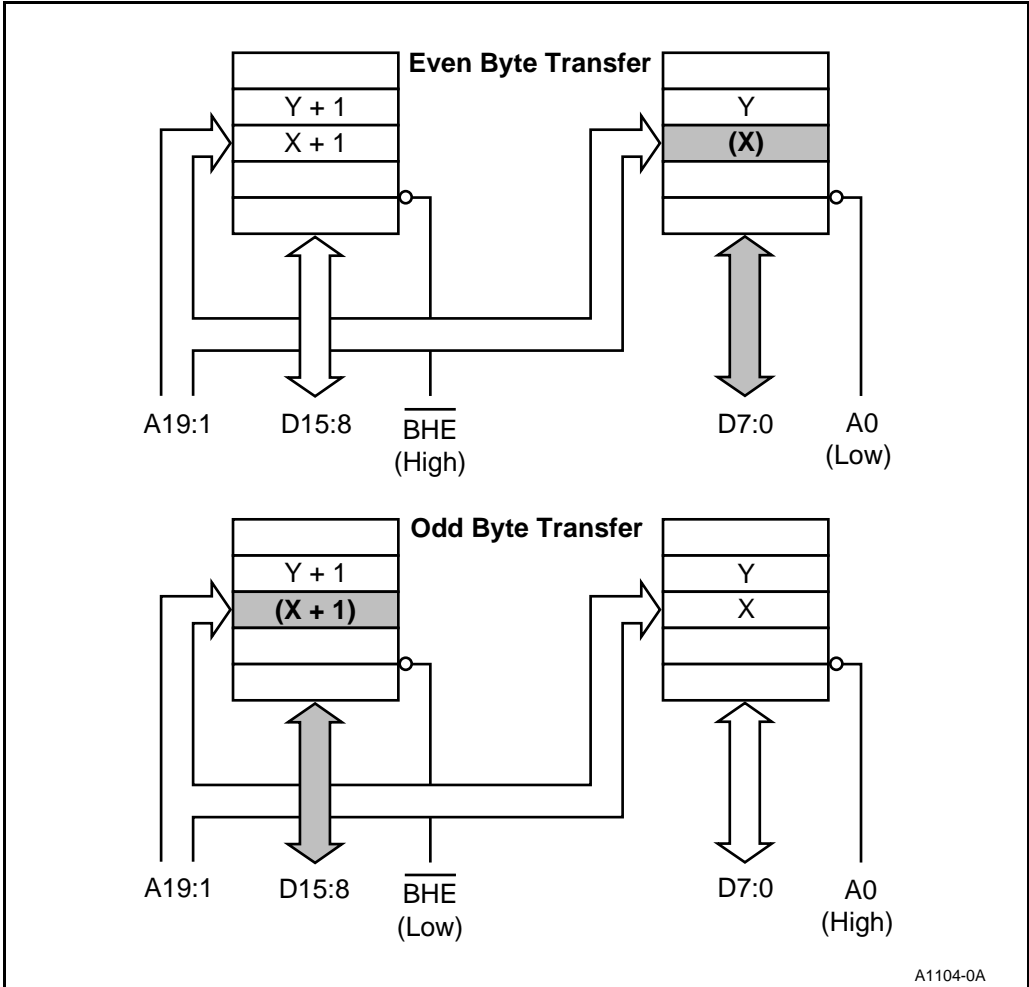

Figure 3-2. 16-Bit Data Bus Byte Transfers

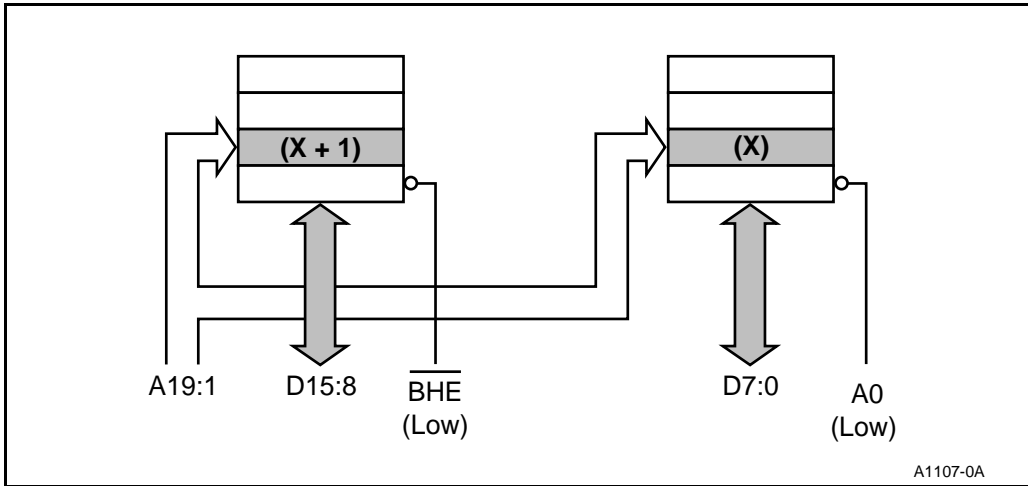

Figure 3-3. 16-Bit Data Bus Even Word Transfers

During a byte read operation, the BIU floats the entire 16-bit data bus, even though the transfer occurs on only one half of the bus. This action simplifies the decoding requirements for read-only devices (e.g., ROM, EPROM, Flash). During the byte read, an external device can drive **both halves** of the bus, and the BIU automatically accesses the correct half. During the byte write operation, the BIU drives both halves of the bus. Information on the half of the bus not involved in the transfer is indeterminate. This action requires that the appropriate bank (defined by $\overline{\text{BHE}}$ or A0 high) be disabled to prevent destroying data.

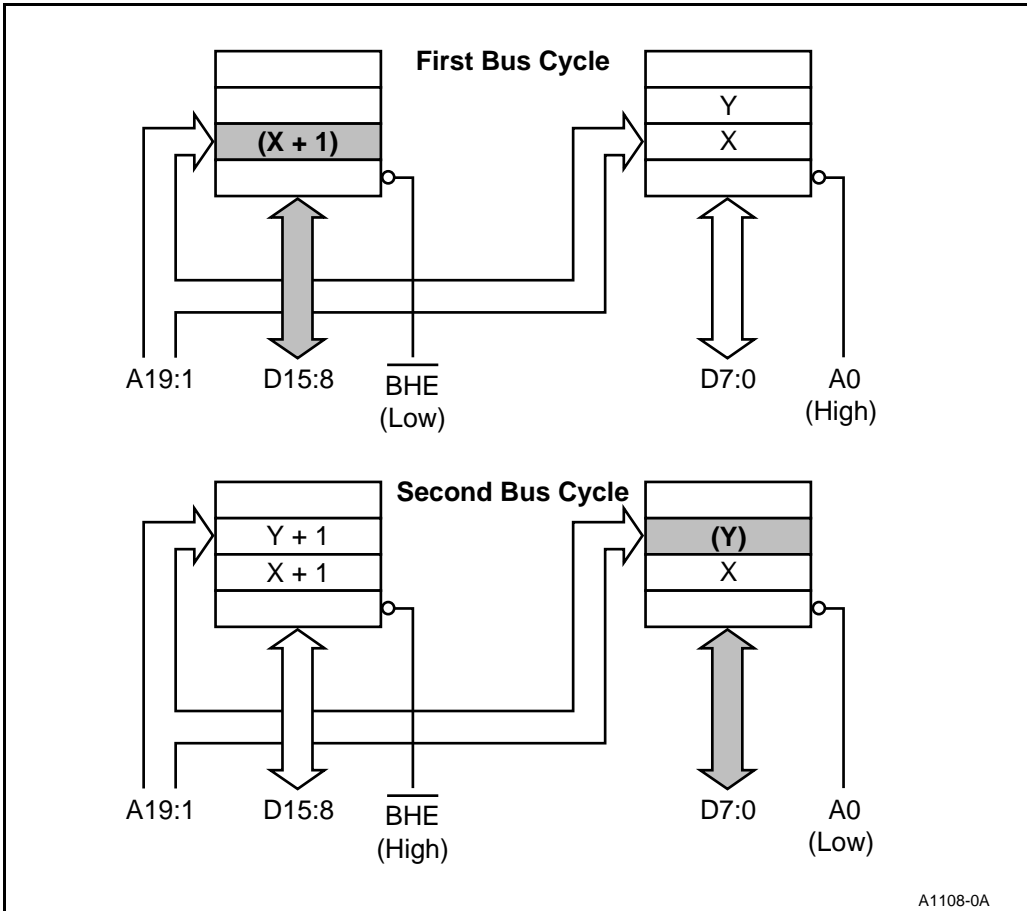

Figure 3-4. 16-Bit Data Bus Odd Word Transfers

3.2.2 8-Bit Data Bus

The memory address space on an 8-bit data bus is physically implemented as one bank of 1 Mbyte (see Figure 3-1 on page 3-2). Address lines A19:0 select a specific byte within the bank. Unlike transfers with a 16-bit bus, byte and word transfers (to even or odd addresses) all transfer data over the same 8-bit bus.

Byte transfers to even or odd addresses transfer information in one bus cycle. Word transfers to even or odd addresses transfer information in two bus cycles. The BIU automatically converts the word access into two consecutive byte accesses, making the operation transparent to the programmer.

For word transfers, the word address defines the first byte transferred. The second byte transfer occurs from the word address plus one. Figure 3-5 illustrates a word transfer on an 8-bit bus interface.

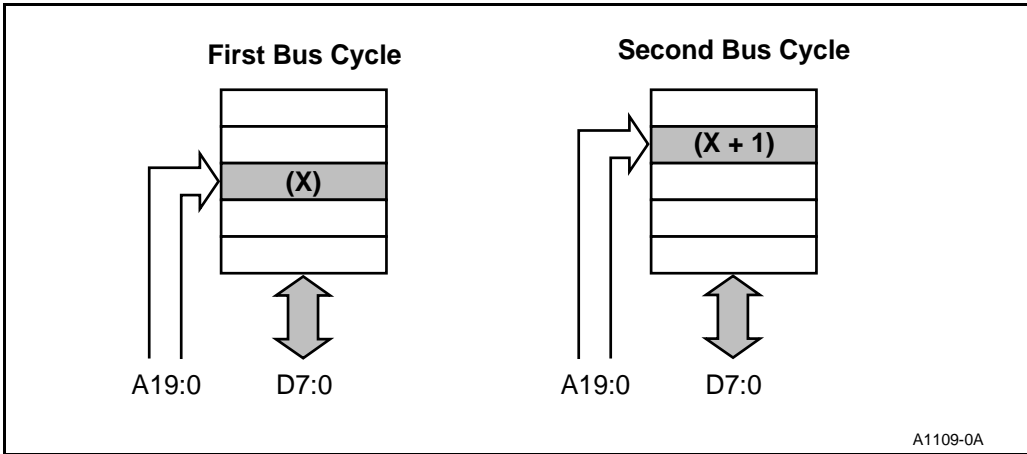

Figure 3-5. 8-Bit Data Bus Word Transfers

3.3 MEMORY AND I/O INTERFACES

The CPU can interface with 8- and 16-bit memory and I/O devices. Memory devices exchange information with the CPU during memory read, memory write and instruction fetch bus cycles. I/O (peripheral) devices exchange information with the CPU during memory read, memory write, I/O read, I/O write and interrupt acknowledge bus cycles. Memory-mapped I/O refers to peripheral devices that exchange information during memory cycles. Memory-mapped I/O allows the full power of the instruction set to be used when communicating with peripheral devices.

I/O read and I/O write bus cycles use a separate I/O address space. Only IN and OUT instructions can access I/O address space, and information must be transferred between the peripheral device and the AX register. The first 256 bytes (0–255) of I/O space can be accessed directly by the I/O instructions. The entire 64 Kbyte I/O address space can be accessed only indirectly, through the DX register. I/O instructions always force address bits A19:16 to zero.

Interrupt acknowledge, or \overline{INTA} , bus cycles access an I/O device intended to increase interrupt input capability. Valid address information is **not** generated as part of the \overline{INTA} bus cycle, and data is transferred only over the lower bank (16-bit device).

3.3.1 16-Bit Bus Memory and I/O Requirements

A 16-bit bus has certain assumptions that must be met to operate properly. Memory used to store instruction operands (i.e., the program) and immediate data must be 16 bits wide. Instruction prefetch bus cycles require that **both banks** be used. The lower bank contains the even bytes of code and the upper bank contains the odd bytes of code.

Memory used to store interrupt vectors and stack data must be 16 bits wide. Memory address space between 0H and 3FFH (1 Kbyte) holds the starting location of an interrupt routine. In response to an interrupt, the BIU fetches two consecutive, even-addressed words from this 1 Kbyte address space. Stack pushes and pops always write or read even-addressed word data.

3.3.2 8-Bit Bus Memory and I/O Requirements

An 8-bit bus interface has no restrictions on implementing the memory or I/O interfaces. All transfers, bytes and words, occur over the single 8-bit bus. Operations requiring word transfers automatically execute two consecutive byte transfers.

3.4 BUS CYCLE OPERATION

The BIU executes a bus cycle to transfer data between any of the integrated units and any external memory or I/O devices (see Figure 3-6). A bus cycle consists of a minimum of four CPU clocks known as “T-states.” A T-state is bounded by one falling edge of CLKOUT to the next falling edge of CLKOUT (see Figure 3-7). Phase 1 represents the low time of the T-state and starts at the high-to-low transition of CLKOUT. Phase 2 represents the high time of the T-state and starts at the low-to-high transition of CLKOUT. Address, data and control signals generated by the BIU go active and inactive at different phases within a T-state.

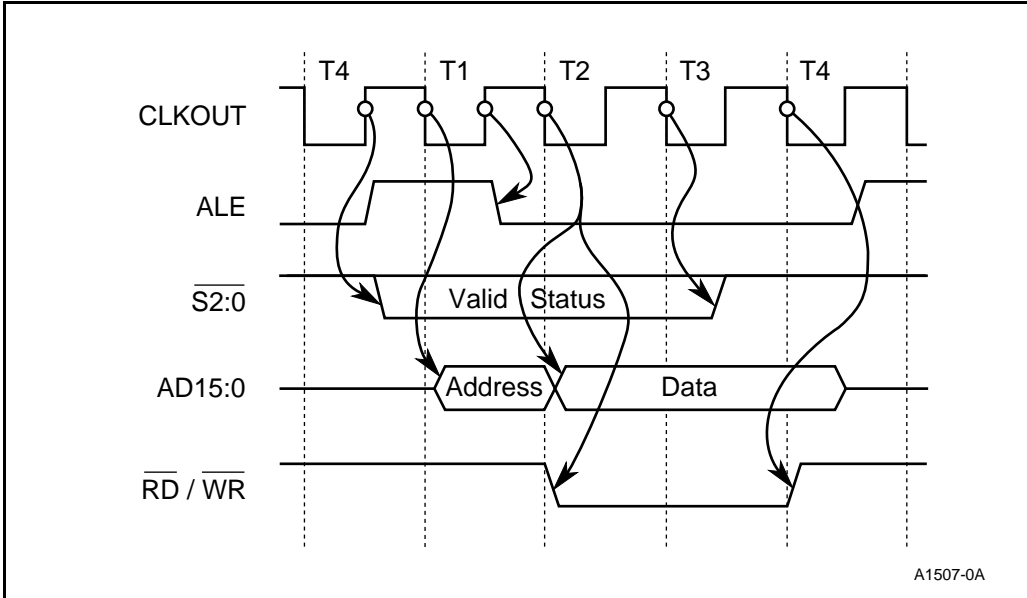

Figure 3-6. Typical Bus Cycle

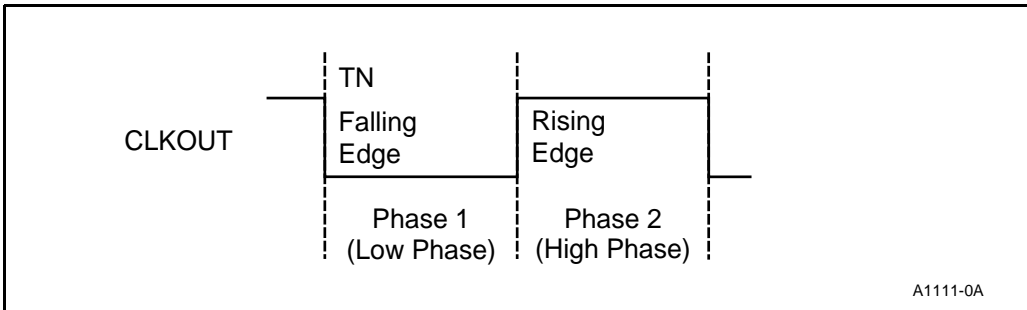

Figure 3-7. T-State Relation to CLKOUT

Figure 3-8 shows the BIU state diagram. Typically a bus cycle consists of four consecutive T-states labeled T1, T2, T3 and T4. A TI (idle) state occurs when no bus cycle is pending. Multiple T3 states occur to generate wait states. The TW symbol represents a wait state.

The operation of a bus cycle can be separated into two phases:

- Address/Status Phase
- Data Phase

The address/status phase starts just before T1 and continues through T1. The data phase starts at T2 and continues through T4. Figure 3-9 illustrates the T-state relationship of the two phases.

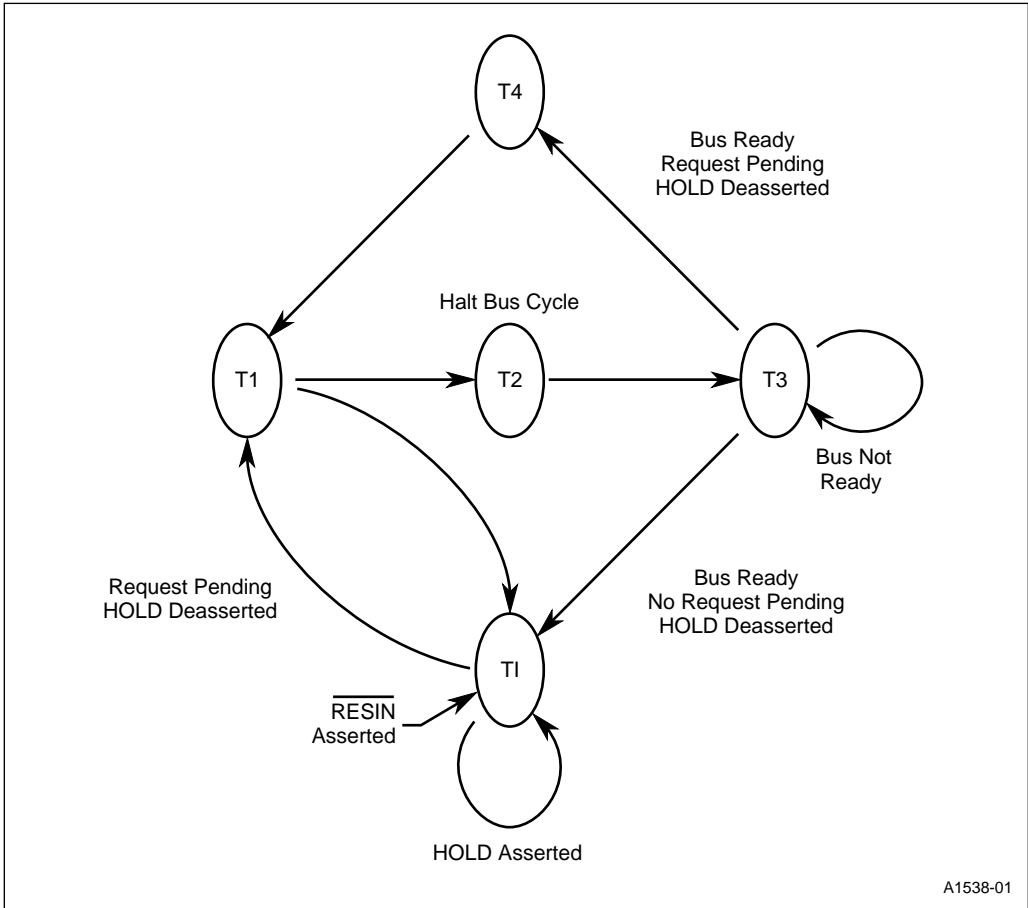

Figure 3-8. BIU State Diagram

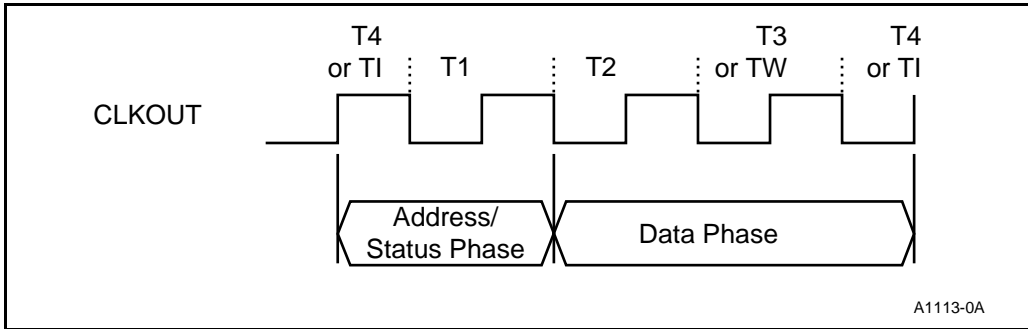

Figure 3-9. T-State and Bus Phases

3.4.1 Address/Status Phase

Figure 3-10 shows signal timing relationships for the address/status phase of a bus cycle. A bus cycle begins with the transition of ALE and $\overline{S2:0}$. These signals transition during phase 2 of the T-state just prior to T1. Either T4 or T1 precedes T1, depending on the operation of the previous bus cycle (see Figure 3-8 on page 3-9).

ALE provides a strobe to latch physical address information. Address is presented on the multiplexed address/data bus during T1 (see Figure 3-10). The falling edge of ALE occurs during the middle of T1 and provides a strobe to latch the address. Figure 3-11 presents a typical circuit for latching addresses.

The status signals ($\overline{S2:0}$) define the type of bus cycle (Table 3-1). $\overline{S2:0}$ remain valid until phase 1 of T3 (or the last TW, when wait states occur). The circuit shown in Figure 3-11 can also be used to extend $\overline{S2:0}$ beyond the T3 (or TW) state.

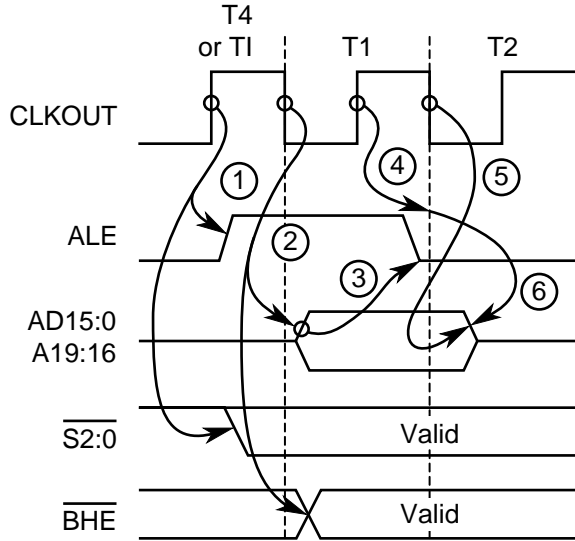

NOTES:

1. T_{CHOV} : Clock high to ALE high, $\overline{S2:0}$ valid.
2. T_{CLOV} : Clock low to address valid, \overline{BHE} valid.
3. T_{AVLL} : Address valid to ALE low (address setup to ALE).
4. T_{CHOV} : Clock high to ALE low.
5. T_{CLOF} : Clock low to address invalid (address hold from clock low).
6. T_{LLAX} : ALE low to address invalid (address hold from ALE).

A1101-0A

Figure 3-10. Address/Status Phase Signal Relationships

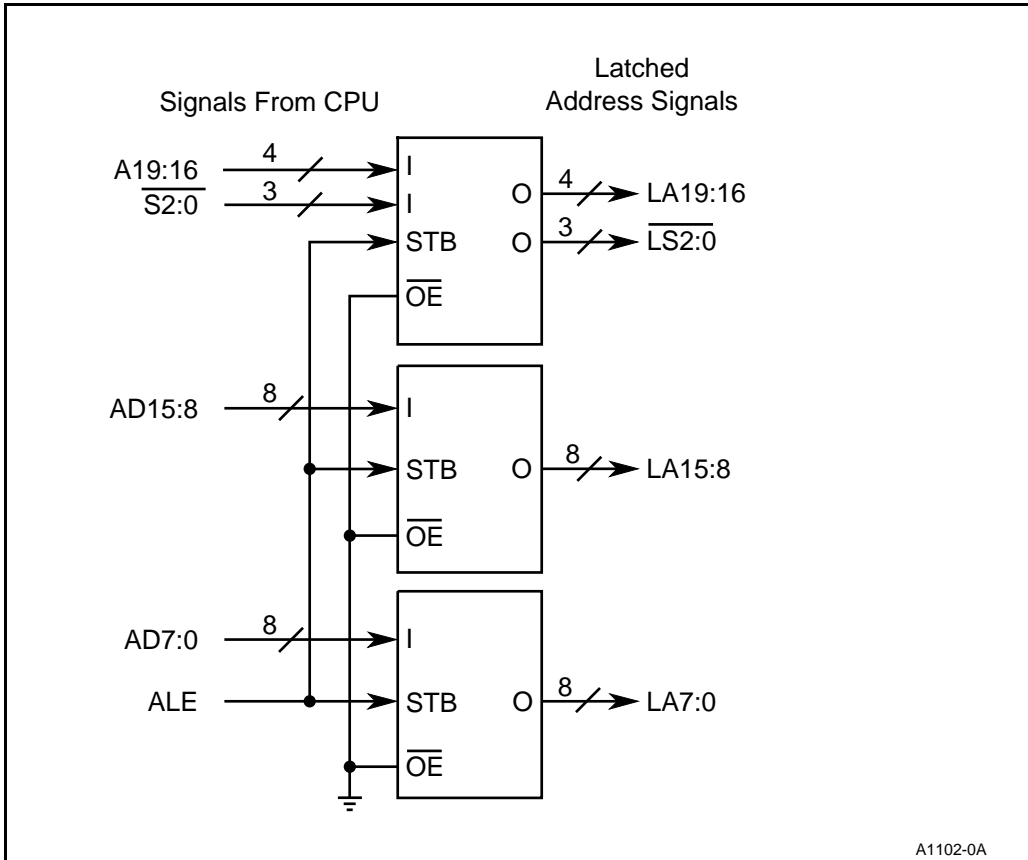

A1102-0A

Figure 3-11. Demultiplexing Address Information

Table 3-1. Bus Cycle Types

Status Bit			Operation
S2	S1	S0	
0	0	0	Interrupt Acknowledge
0	0	1	I/O Read
0	1	0	I/O Write
0	1	1	Halt
1	0	0	Instruction Prefetch
1	0	1	Memory Read
1	1	0	Memory Write
1	1	1	Idle (passive)

3.4.2 Data Phase

Figure 3-12 shows the timing relationships for the data phase of a bus cycle. The only bus cycle type that does not have a data phase is a bus halt. During the data phase, the bus transfers information between the internal units and the memory or peripheral device selected during the address/status phase. Appropriate control signals become active to coordinate the transfer of data.

The data phase begins at phase 1 of T2 and continues until phase 2 of T4 or TI. The length of the data phase varies depending on the number of wait states. Wait states occur after T3 and before T4 or TI.

3.4.3 Wait States

Wait states extend the data phase of the bus cycle. Memory and I/O devices that cannot provide or accept data in the minimum four CPU clocks require wait states. Figure 3-13 shows a typical bus cycle with wait states inserted.

The bus ready inputs (ARDY and SRDY) and the Chip-Select Unit control bus cycle wait states. Only the bus ready inputs are described in this chapter. (See Chapter 6, “Chip-Select Unit,” for additional information.)

Figure 3-14 shows a simplified block diagram of the ARDY and SRDY inputs. Either ARDY or SRDY active signals a bus ready condition; therefore, both pins must be inactive to signal a not-ready condition. Depending on the size and characteristics of the system, ready implementation can take one of two approaches: normally not-ready or normally ready.

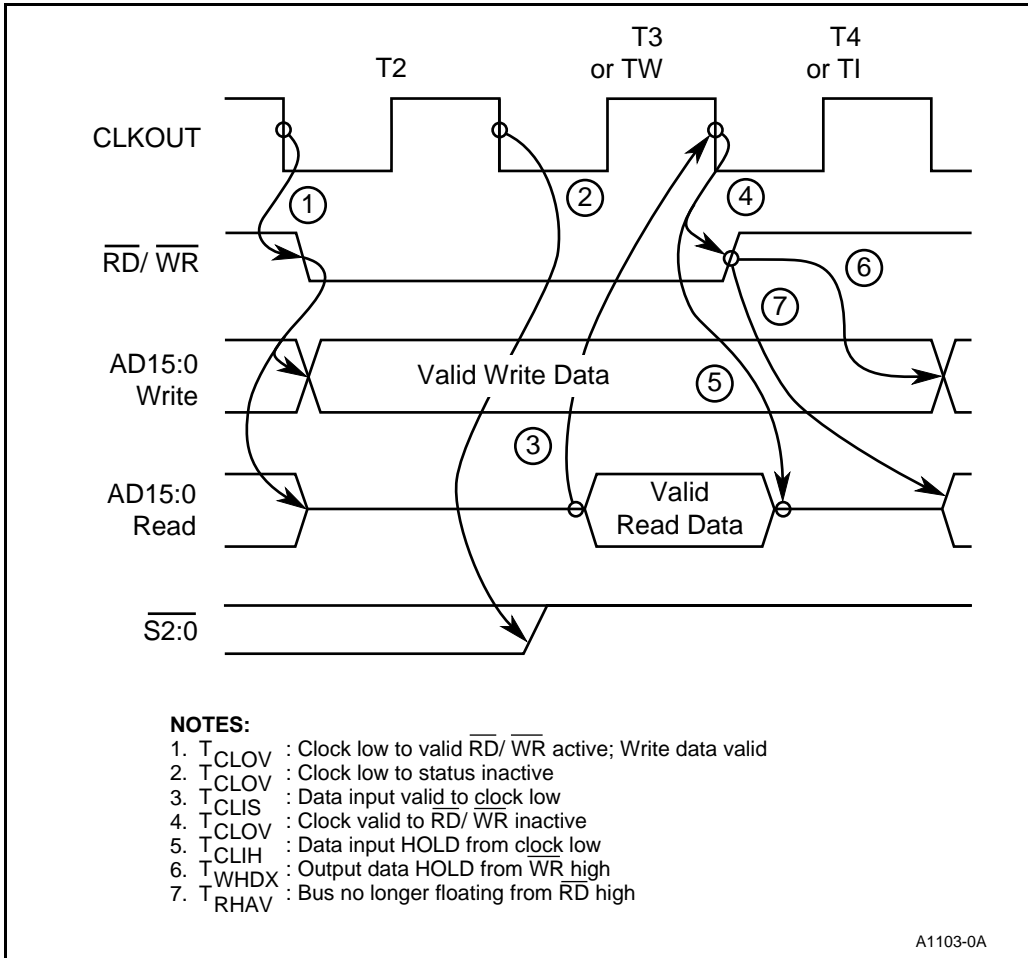
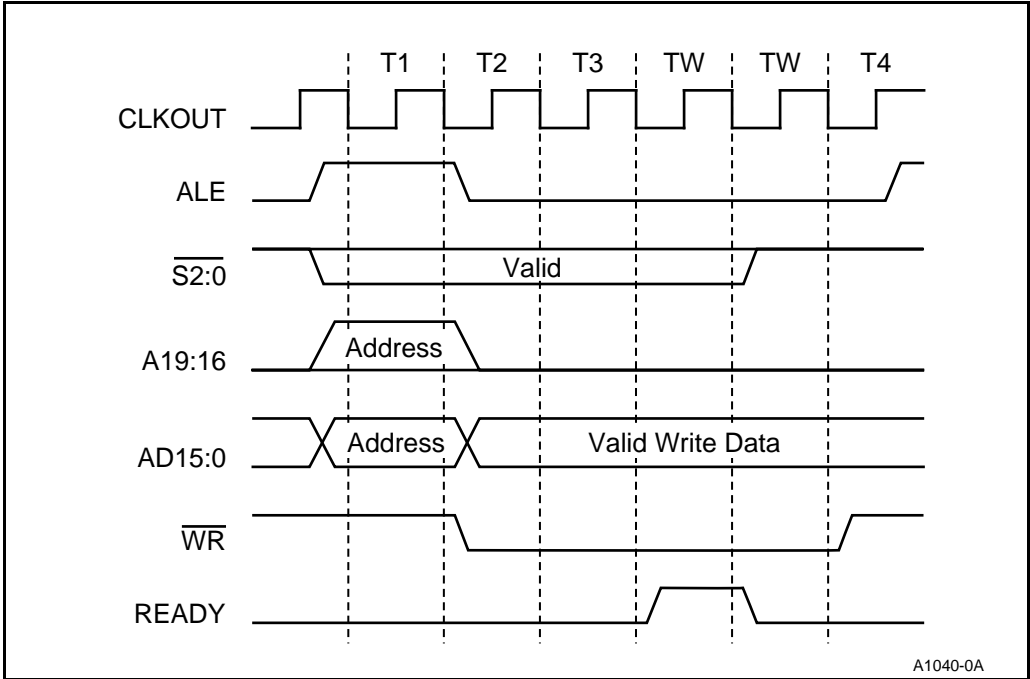
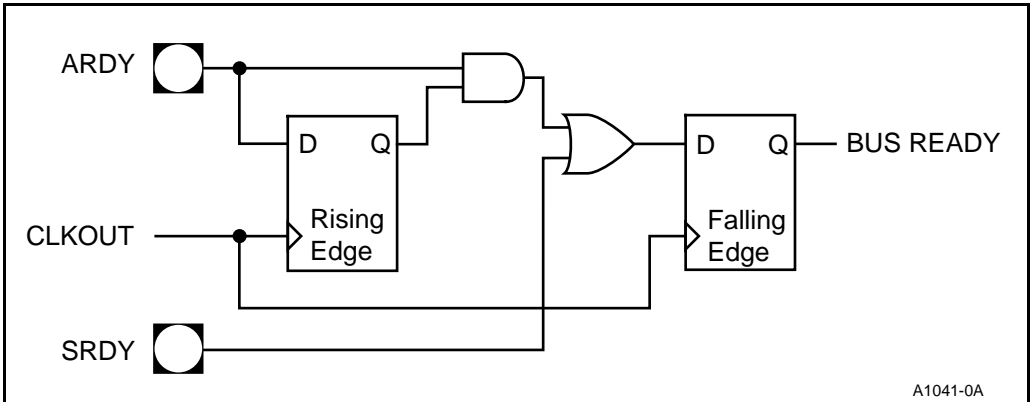

Figure 3-12. Data Phase Signal Relationships



A1040-0A

Figure 3-13. Typical Bus Cycle with Wait States



A1041-0A

Figure 3-14. ARDY and SRDY Pin Block Diagram

A normally not-ready system is one in which ARDY and SRDY remain low at all times except to signal a ready condition. For any bus cycle, only the selected device drives either ready input high to complete the bus cycle. The circuit shown in Figure 3-15 illustrates a simple circuit to generate a normally not-ready signal. **Note that if no device is selected the bus remains not-ready indefinitely.** Systems with many slow devices that cannot operate at the maximum bus bandwidth usually implement a normally not-ready signal.

The start of a bus cycle clears the wait state module and forces ARDY low. After every rising edge of CLKOUT, INPUT1 and INPUT2 are shifted through the module and eventually drive ARDY high. Assuming INPUT1 and INPUT2 are valid prior to phase 2 of T2, no delay through the module causes one wait state. Each additional clock delay through the module generates one additional wait state. Two inputs are used to establish different wait state conditions. The same circuit works for SRDY, but no delay through the module results in no wait states.

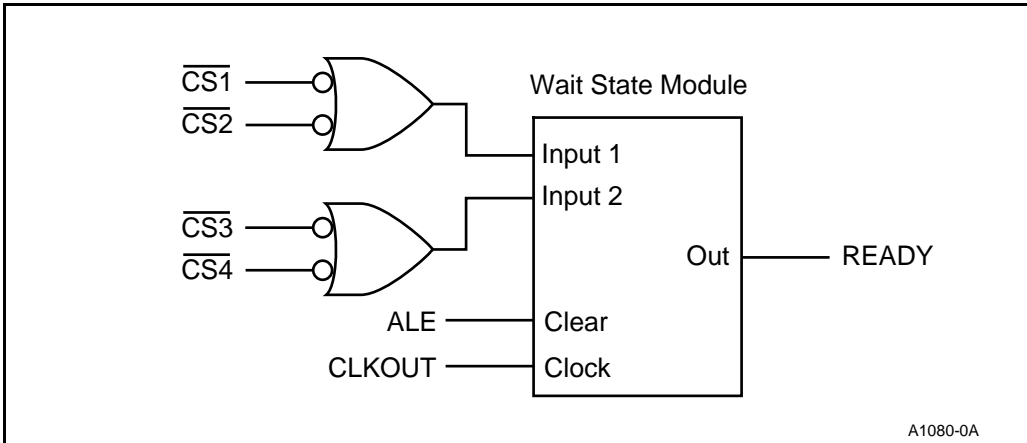

Figure 3-15. Generating a Normally Not-Ready Bus Signal

A normally ready signal remains high at all times except when the selected device needs to signal a not-ready condition. For any bus cycle, only the selected device drives the ready input (or inputs) low to delay the completion of the bus cycle. The circuit shown in Figure 3-16 illustrates a simple circuit to generate a normally ready signal. **Note that if no device is selected the bus remains ready.** Systems that have few or no devices requiring wait states usually implement a normally ready signal.

The start of a bus cycle preloads a zero shifter and forces SRDY active (high). SRDY remains active if neither $\overline{CS1}$ or $\overline{CS2}$ goes low. Should either $\overline{CS1}$ or $\overline{CS2}$ go low, zeros are shifted out on every rising edge of CLKOUT, causing SRDY to go inactive. At the end of the shift pattern, SRDY is forced active again. Assuming $\overline{CS1}$ and $\overline{CS2}$ are active just prior to phase 2 of T2, shifting one zero through the module causes one wait state. Each additional zero shifted through the module generates one wait state. The same circuit works for ARDY, but shifting one zero through the module generates two wait states.

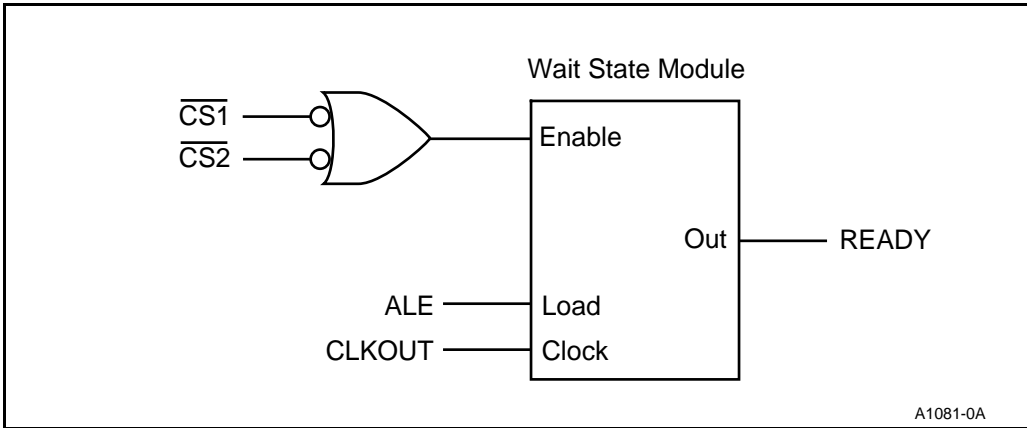

Figure 3-16. Generating a Normally Ready Bus Signal

The ARDY input has two major timing concerns that can affect whether a normally ready or normally not-ready signal may be required. Two latches capture the state of the ARDY input (see Figure 3-14 on page 3-15). The first latch captures ARDY on the phase 2 clock edge. The second latch captures ARDY **and** the result of first latch on the phase 1 clock edge. The following items define the requirements of the ARDY input to meet ready or not-ready bus conditions.

- The bus is **ready** if **both** of these two conditions are true:
 - ARDY is active prior to the phase 2 clock edge, **and**
 - ARDY remains active after the phase 1 clock edge.
- The bus is **not-ready** if **either** of these two conditions is true:
 - ARDY is inactive prior to the phase 2 clock edge, **or**
 - ARDY is inactive prior to the phase 1 clock edge.

A single latch captures the state of the SRDY input (see Figure 3-14 on page 3-15). SRDY must be valid by the phase 1 clock edge. The following items define the requirements of the SRDY input to meet ready or not-ready bus conditions.

- The bus is **ready** if SRDY is active prior to the phase 1 clock edge.
- The bus is **not-ready** if SRDY is inactive prior to the phase 1 clock edge.

A normally not-ready system must generate a valid ARDY input at phase 2 of T2 or a valid SRDY input at phase 1 of T3 to prevent wait states. If it cannot, then running without wait states requires a normally ready system. Figure 3-17 illustrates the timing necessary to prevent wait states in a normally not-ready system. Figure 3-17 also shows how to terminate a bus cycle with wait states in a normally not-ready system.

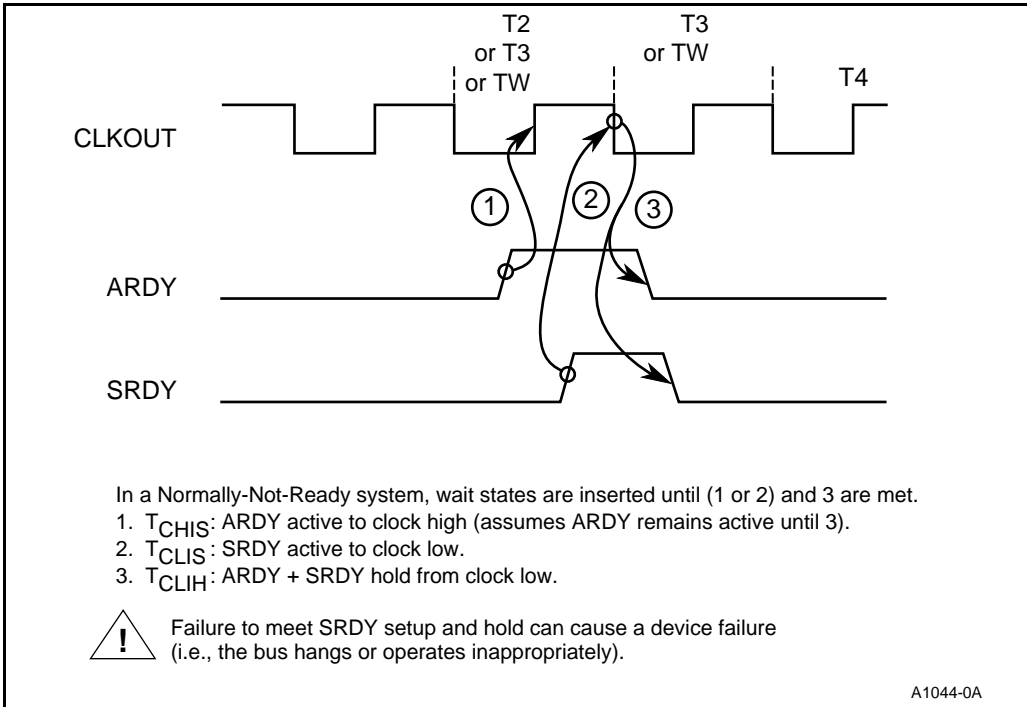

Figure 3-17. Normally Not-Ready System Timing

A valid not-ready input can be generated as late as phase 1 of T3 to insert wait states in a normally ready system. A normally not-ready system must run wait states if the not-ready condition cannot be met in time. Figure 3-18 illustrates the minimum and maximum timing necessary to insert wait states in a normally ready system. Figure 3-18 also shows how to terminate a bus cycle with wait states in a normally ready system.

The BIU can execute an indefinite number of wait states. However, bus cycles with large numbers of wait states limit the performance of the CPU and the integrated peripherals. CPU performance suffers because the instruction prefetch queue cannot be kept full. Integrated peripheral performance suffers because the maximum bus bandwidth decreases.

3.4.4 Idle States

Under most operating conditions, the BIU executes consecutive (back-to-back) bus cycles. However, several conditions cause the BIU to become idle. An idle condition occurs between bus cycles (see Figure 3-8 on page 3-9) and may last an indefinite period of time, depending on the instruction sequence.

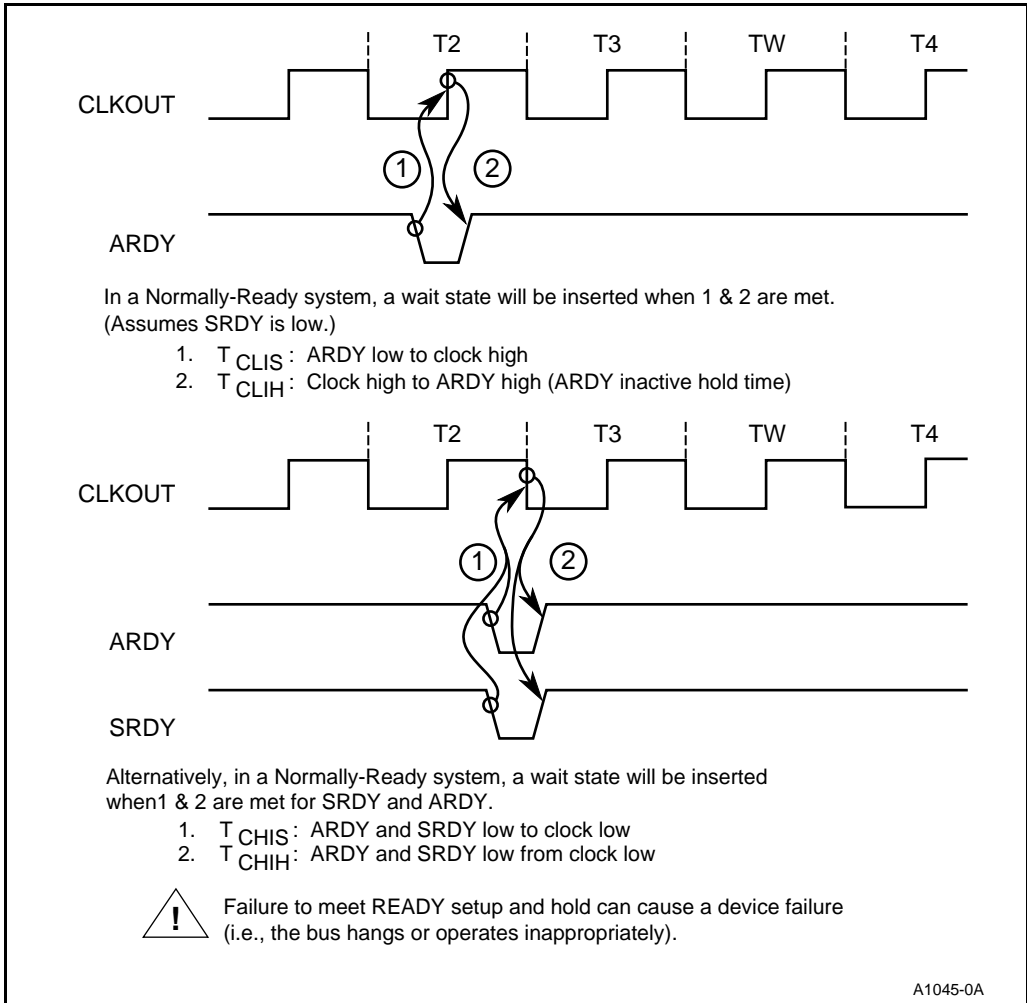

Figure 3-18. Normally Ready System Timings

Conditions causing the BIU to become idle include the following.

- The instruction prefetch queue is full.
- An effective address calculation is in progress.
- The bus cycle inherently requires idle states (e.g., interrupt acknowledge, locked operations).
- Instruction execution forces idle states (e.g., HLT, WAIT).

An idle bus state may or may not drive the bus. An idle bus state following a bus read cycle continues to float the bus. An idle bus state following a bus write cycle continues to drive the bus. The BIU drives no control strobes active in an idle state except to indicate the start of another bus cycle.

3.5 BUS CYCLES

There are four basic types of bus cycles: read, write, interrupt acknowledge and halt. Interrupt acknowledge and halt bus cycles define special bus operations and require separate discussions. Read bus cycles include memory, I/O and instruction prefetch bus operations. Write bus cycles include memory and I/O bus operations. All read and write bus cycles have the same basic format.

The following sections present timing equations containing symbols found in the data sheet. The timing equations provide information necessary to start a worst-case design analysis.

3.5.1 Read Bus Cycles

Figure 3-19 illustrates a typical read cycle. Table 3-2 lists the three types of read bus cycles.

Table 3-2. Read Bus Cycle Types

Status Bit			Bus Cycle Type
S2	S1	S0	
0	0	1	Read I/O — Initiated by the Execution Unit for IN, OUT, INS, OUTS instructions or by the DMA Unit. A19:16 are driven to zero (see Chapter 10, "Direct Memory Access Unit").
1	0	0	Instruction Prefetch — Initiated by the BIU. Data read from the bus fills the prefetch queue.
1	0	1	Read Memory — A19:0 select the desired byte or word memory location.

Figure 3-20 illustrates a typical 16-bit interface connection to a read-only device interface. The same example applies to an 8-bit bus system, except that no devices connect to an upper bus. Four parameters (Table 3-3) must be evaluated when determining the compatibility of a memory (or I/O) device. T_{ADLTCH} defines the delay through the address latch.

Table 3-3. Read Cycle Critical Timing Parameters

Memory Device Parameter	Description	Equation
T_{OE}	Output enable (\overline{RD} low) to data valid	$2T - T_{CLOV2} - T_{CLIS}$
T_{ACC}	Address valid to data valid	$3T - T_{CLOV2} - T_{ADLTCH} - T_{CLIS}$
T_{CE}	Chip enable (\overline{UCS}) to data valid	$3T - T_{CLOV2} - T_{CLIS}$
T_{DF}	Output disable (\overline{RD} high) to output float	T_{RHAX}

T_{OE} , T_{ACC} and T_{CE} define the maximum data access requirements for the memory device. These device parameters must be **less** than the value calculated in the equation column. An equal to or greater than result indicates that wait states must be inserted into the bus cycle.

T_{DF} determines the maximum time the memory device can float its outputs before the next bus cycle begins. A T_{DF} value greater than the equation result indicates a buffer fight. A buffer fight means two (or more) devices are driving the bus **at the same time**. This can lead to short circuit conditions, resulting in large current spikes and possible device damage.

T_{RHAX} cannot be lengthened (other than by slowing the clock rate). To resolve a buffer fight condition, choose a faster device or buffer the AD bus (see “Buffering the Data Bus” on page 3-36).

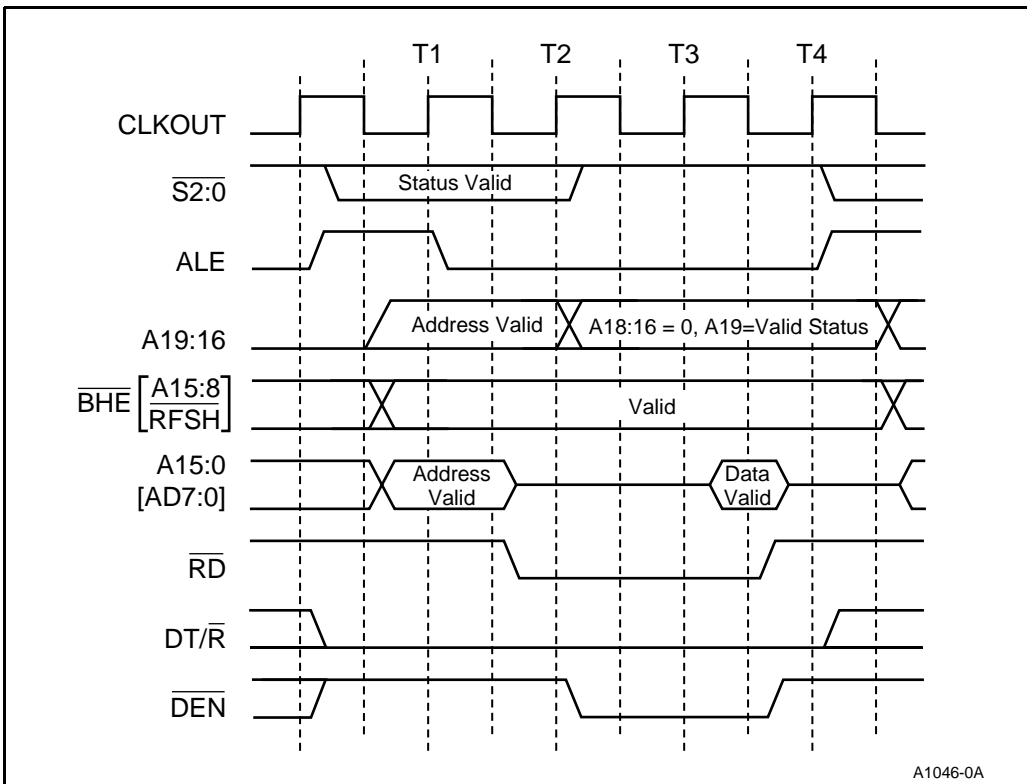

Figure 3-19. Typical Read Bus Cycle

3.5.1.1 Refresh Bus Cycles

A refresh bus cycle operates similarly to a normal read bus cycle except for the following:

- For a 16-bit data bus, address bit A0 and $\overline{\text{BHE}}$ drive to a 1 (high) and the data value on the bus is ignored.
- For an 8-bit data bus, address bit A0 drives to a 1 (high) and $\overline{\text{RFSH}}$ is driven active (low). The data value on the bus is ignored. $\overline{\text{RFSH}}$ has the same bus timing as $\overline{\text{BHE}}$.

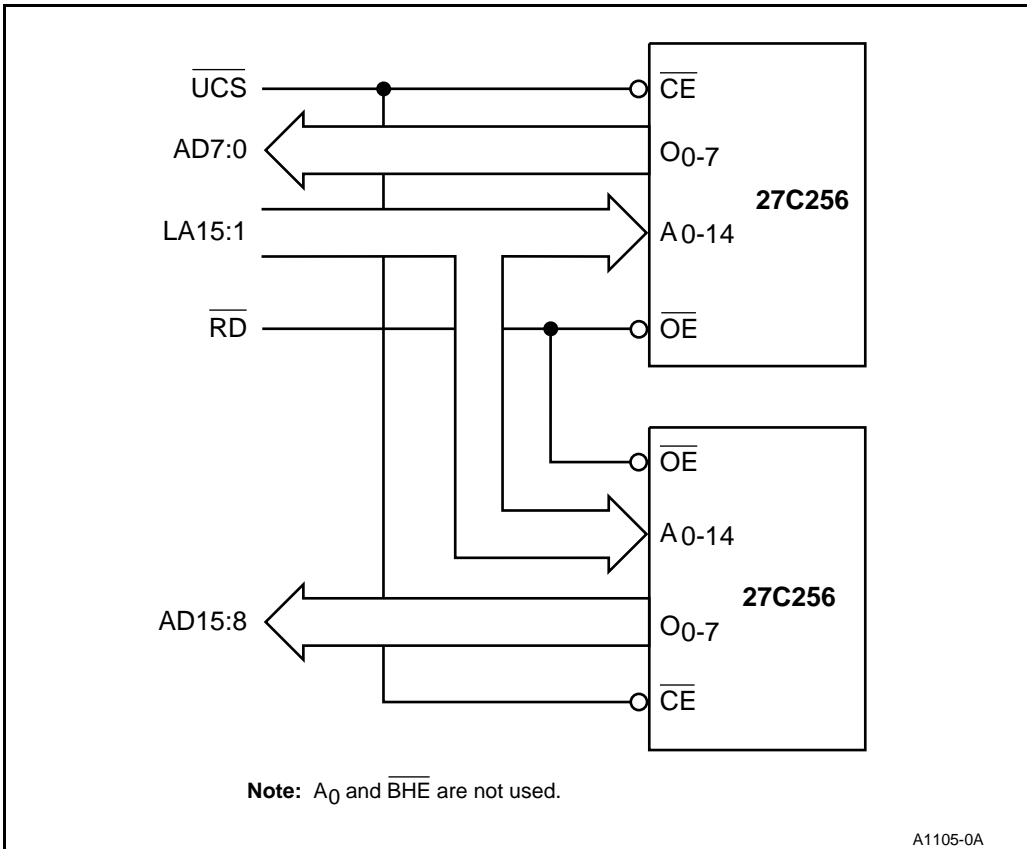

Figure 3-20. Read-Only Device Interface

3.5.2 Write Bus Cycles

Figure 3-21 illustrates a typical write bus cycle. The bus cycle starts with the transition of ALE high and the generation of valid status bits $\overline{\text{S2:0}}$. The bus cycle ends when $\overline{\text{WR}}$ transitions high (inactive), although data remains valid for one additional clock. Table 3-4 lists the two types of write bus cycles.

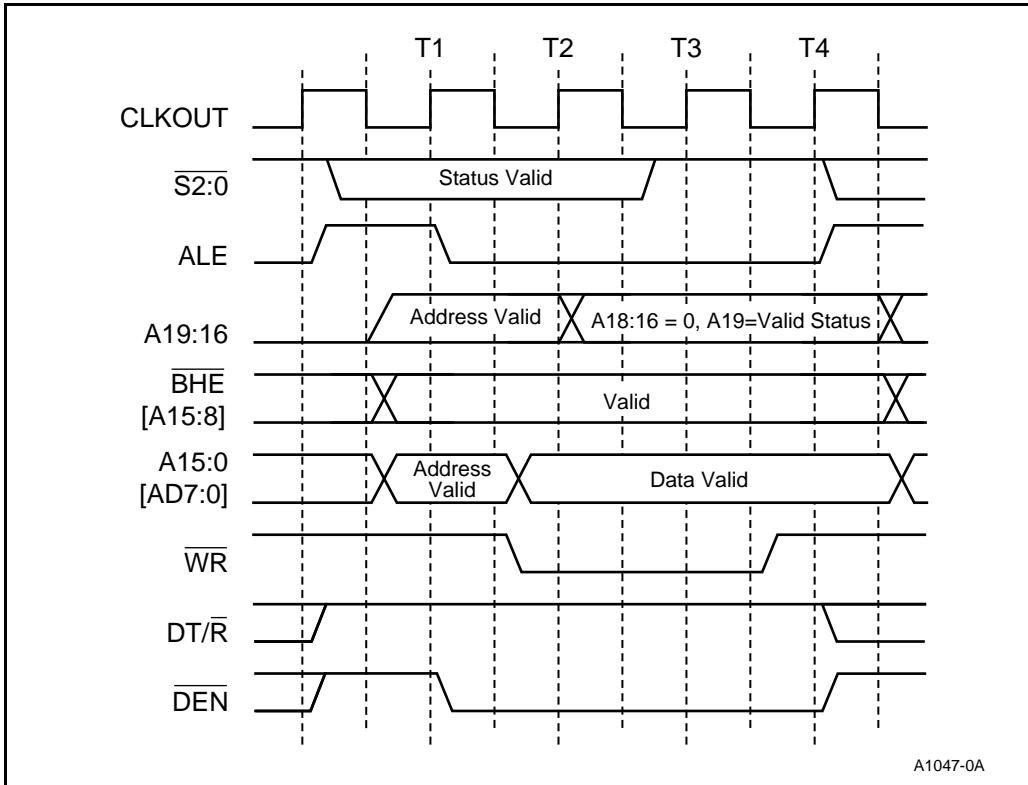

Figure 3-21. Typical Write Bus Cycle

Table 3-4. Write Bus Cycle Types

Status Bits			Bus Cycle Type
S2	S1	S0	
0	1	0	Write I/O — Initiated by executing IN, OUT, INS, OUTS instructions or by the DMA Unit. A15:0 select the desired I/O port. A19:16 are driven to zero (see Chapter 10, “Direct Memory Access Unit”).
1	1	0	Write Memory — Initiated by any of the Byte/ Word memory instructions or the DMA Unit. A19:0 selects the desired byte or word memory location.

Figure 3-22 illustrates a typical 16-bit interface connection to a read/write device. Write bus cycles have many parameters that must be evaluated in determining the compatibility of a memory (or I/O) device. Table 3-5 lists some critical write bus cycle parameters.

Most memory and peripheral devices latch data on the rising edge of the write strobe. Address, chip-select and data must be valid (set up) prior to the rising edge of \overline{WR} . T_{AW} , T_{CW} and T_{DW} define the minimum data setup requirements. The value calculated by their respective equations must be greater than the device requirements. To increase the calculated value, insert wait states.

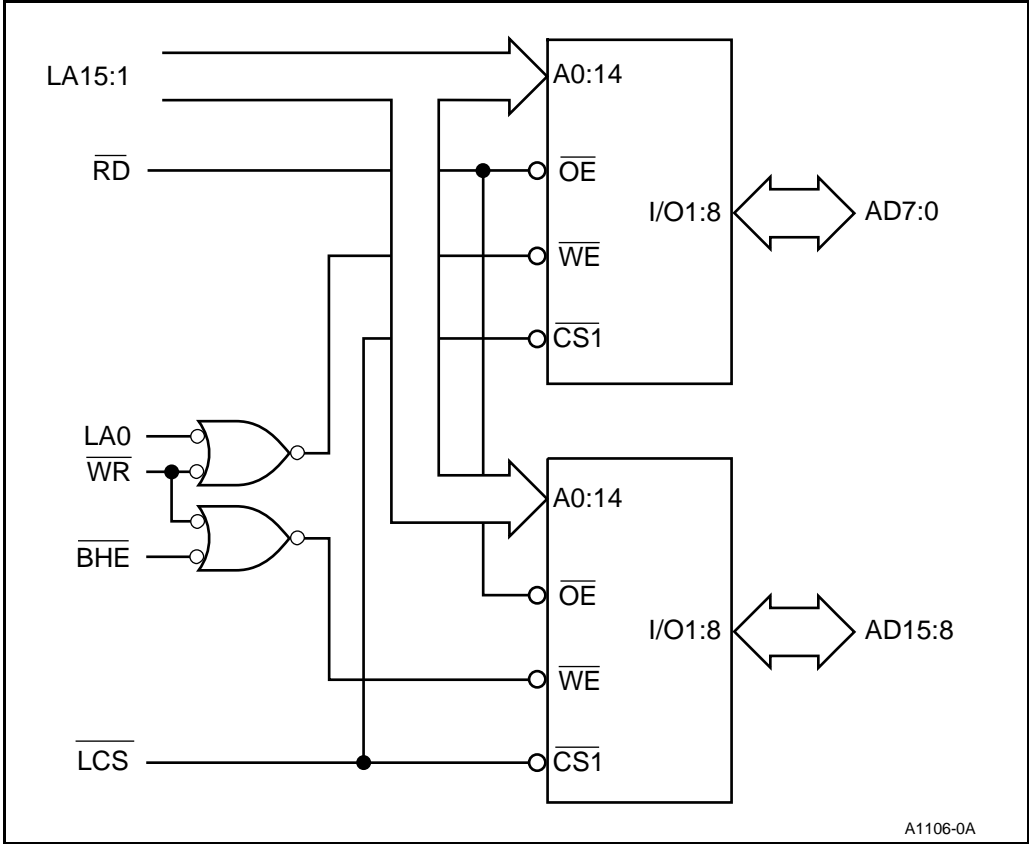

Figure 3-22. 16-Bit Bus Read/Write Device Interface

The minimum device data hold time (from \overline{WR} high) is defined by T_{DH} . The calculated value must be greater than the minimum device requirements; however, the value can be changed only by decreasing the clock rate.

Table 3-5. Write Cycle Critical Timing Parameters

Memory Device Parameter	Description	Equation
T_{WC}	Write cycle time	$4T$
T_{AW}	Address valid to end of write strobe (\overline{WR} high)	$3T - T_{ADLTCH}$
T_{CW}	Chip enable (\overline{LCS}) to end of write strobe (\overline{WR} high)	$3T$
T_{WR}	Write recover time	T_{WHLH}
T_{DW}	Data valid to write strobe (\overline{WR} high)	$2T$
T_{DH}	Data hold from write strobe (\overline{WR} high)	T_{WHDX}
T_{WP}	Write pulse width	T_{WLWH}

T_{WC} and T_{WP} define the minimum time (maximum frequency) a device can process write bus cycles. T_{WR} determines the minimum time from the end of the current write cycle to the start of the next write cycle. All three parameters require that calculated values be greater than device requirements. The calculated T_{WC} and T_{WP} values increase with the insertion of wait states. The calculated T_{WR} value, however, can be changed only by decreasing the clock rate.

3.5.3 Interrupt Acknowledge Bus Cycle

Interrupt expansion is accomplished by interfacing the Interrupt Control Unit with a peripheral device such as the 82C59A Programmable Interrupt Controller. (See Chapter 8, “Interrupt Control Unit,” for more information.) The BIU controls the bus cycles required to fetch vector information from the peripheral device, then passes the information to the CPU. These bus cycles, collectively known as Interrupt Acknowledge bus cycles, operate similarly to read bus cycles. However, instead of generating \overline{RD} to enable the peripheral, the \overline{INTA} signal is used. Figure 3-23 illustrates a typical Interrupt Acknowledge (or \overline{INTA}) bus cycle.

An Interrupt Acknowledge bus cycle consists of two consecutive bus cycles. \overline{LOCK} is generated to indicate the sequential bus operation. The second bus cycle strobes vector information only from the lower half of the bus (D7:0). In a 16-bit bus system, the upper half of the bus (D15:8) floats.

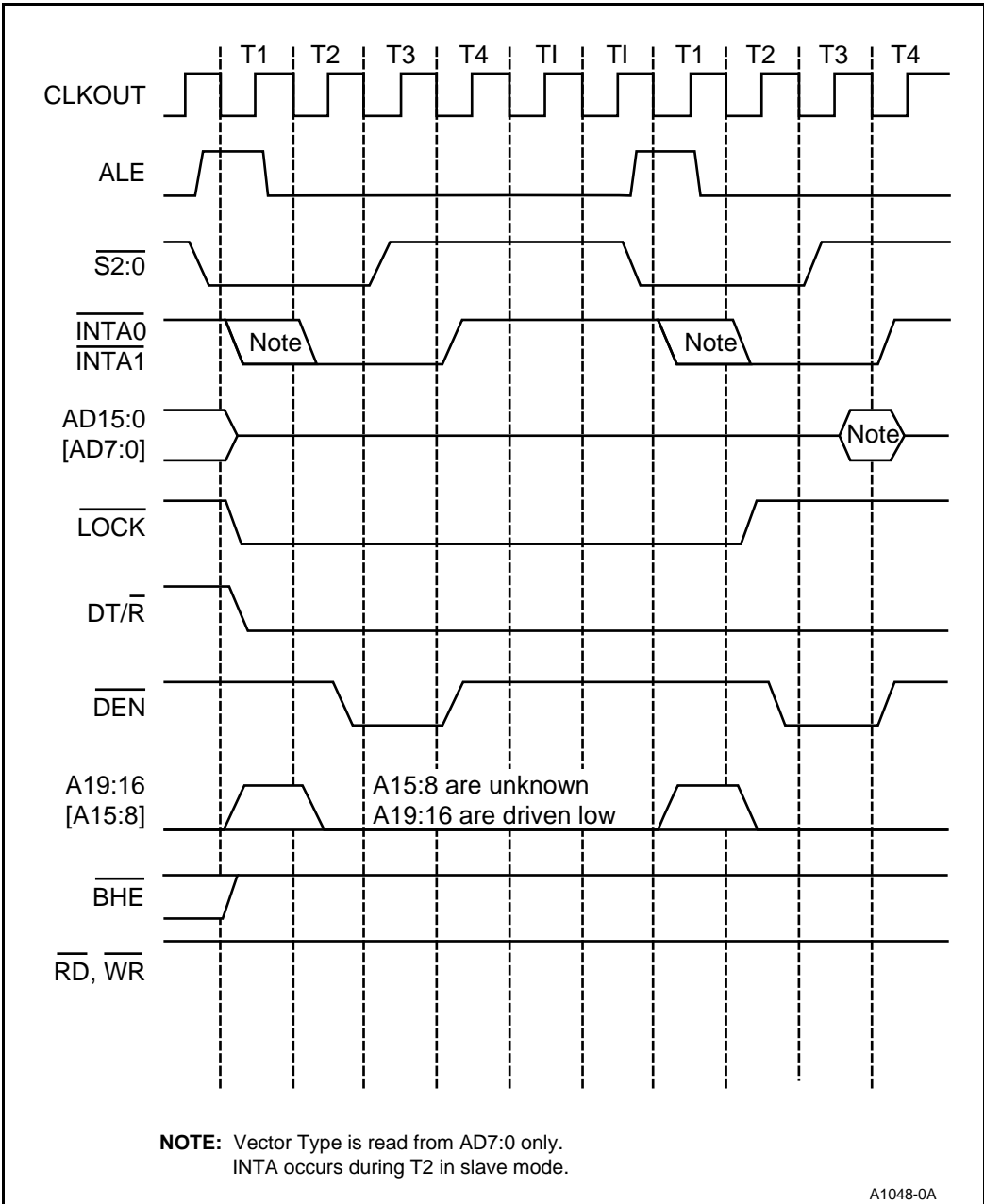

Figure 3-23. Interrupt Acknowledge Bus Cycle

Figure 3-24 shows a typical 82C59A interface example. Bus ready must be provided to terminate both bus cycles in the interrupt acknowledge sequence.

NOTE

Due to an internal condition, external ready is ignored if the device is configured in Cascade mode and the Peripheral Control Block (PCB) is located at 0000H in I/O space. In this case, wait states **cannot** be added to interrupt acknowledge bus cycles. However, you **can** add wait states to interrupt acknowledge cycles if the PCB is located at any other address.

3.5.3.1 System Design Considerations

Although ALE is generated for both bus cycles, the BIU does not drive valid address information. Actually, all address bits except A19:16 float during the time ALE becomes active (on both 8- and 16-bit bus devices). Address-decoding circuitry must be disabled for Interrupt Acknowledge bus cycles to prevent erroneous operation.

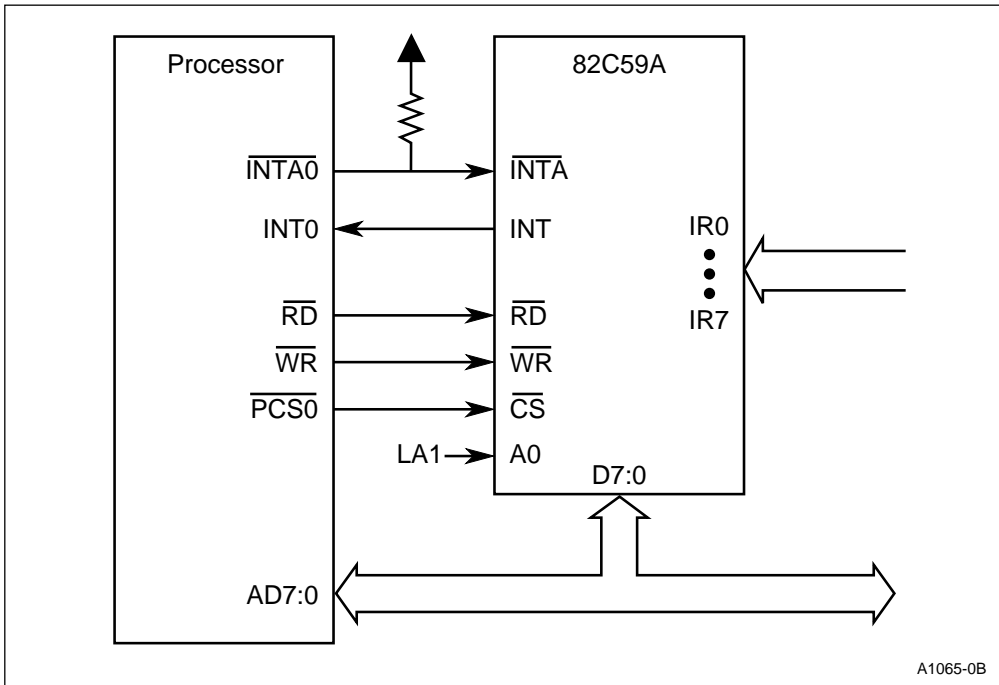

Figure 3-24. Typical 82C59A Interface

3.5.4 HALT Bus Cycle

Suspending the CPU reduces device power consumption and potentially reduces interrupt latency time. The HLT instruction initiates two events:

1. Suspends the Execution Unit.
2. Instructs the BIU to execute a HALT bus cycle.

The Idle or Powerdown power management mode (or the absence of both of them, known as Active Mode) affects the operation of the bus HALT cycle. The effects relating to BIU operation and the HALT bus cycle are described in this chapter. Chapter 5, “Clock Generation and Power Management,” discusses the concepts of Active, Idle and Powerdown power management modes.

After executing a HALT bus cycle, the BIU suspends operation until one of the following events occurs:

- An interrupt is generated.
- A bus HOLD is generated (except when Powerdown mode is enabled).
- A DMA request is generated (except when Powerdown mode is enabled).
- A refresh request is generated (except when Powerdown mode is enabled).

Figure 3-25 shows the operation of a HALT bus cycle. The address/data bus either floats or drives during T1, depending on the next bus cycle to be executed by the BIU. Under most instruction sequences, the BIU floats the address/data bus because the next operation would most likely be an instruction prefetch. However, if the HALT occurs just after a bus write operation, the address/data bus drives either data or address information during T1. A19:16 continue to drive the previous bus cycle information under most instruction sequences (otherwise, they drive the next prefetch address). The BIU always operates in the same way for any given instruction sequence.

The Chip-Select Unit prevents a programmed chip-select from going active during a HALT bus cycle. However, chip-selects generated by external decoder circuits must be disabled for HALT bus cycles.

After several TI bus states, all address/data, address/status and bus control pins drive to a known state when Powerdown or Idle Mode is enabled. The address/data and address/status bus pins force a low (0) state. Bus control pins force their inactive state. Figure 3-3 lists the state of each pin after entering the HALT bus state.

Table 3-6. HALT Bus Cycle Pin States

Pin(s)	Pin State	
	No Powerdown or Idle Mode	Powerdown or Idle Mode
AD15:0 (AD7:0 for 8-bit)	Float	Drive Zero
A15:8 (8-bit)	Drive Address	Drive Zero
A19:16	Drive 8H or Zero	Drive Zero
$\overline{\text{BHE}}$ (16-bit)	Drive Last Value	Drive One
$\overline{\text{RD}}$, $\overline{\text{WR}}$, $\overline{\text{DEN}}$, DT/R, $\overline{\text{RFSH}}$ (8-bit), $\overline{\text{S2:0}}$	Drive One	Drive One

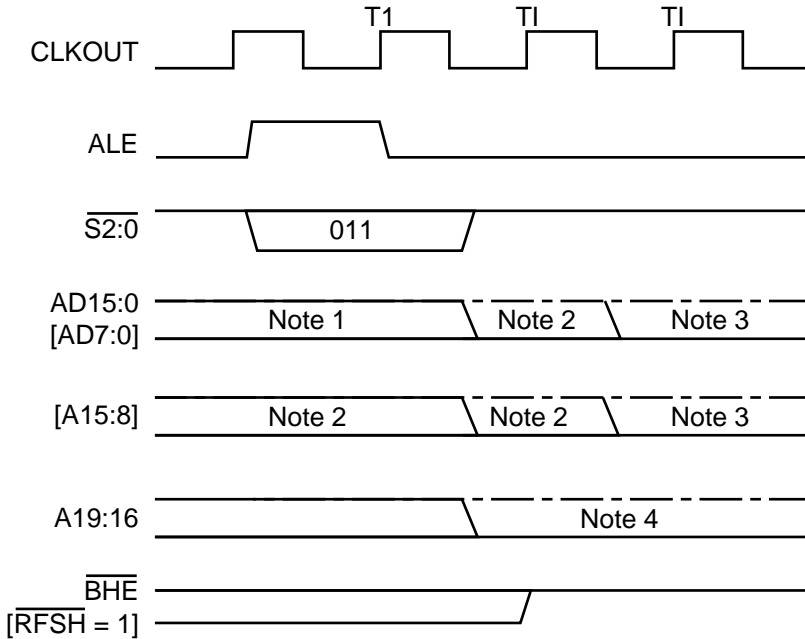

NOTES:

1. The AD15:0 [AD7:0] bus can be floating, driving a previous write data value, or driving the next instruction prefetch address value. For an 8-bit device, A15:8 either drives the previous bus address value or the next instruction prefetch address value.
2. The AD15:0 bus, or AD7:0 and A15:8 buses for an 8-bit device, drive to a zero (all low) at this time if Powerdown Mode is enabled. When Powerdown Mode is not enabled, the AD15:0 [AD7:0] bus either floats or drives previous write data, and A15:8 (8-bit device) continues to drive its previous value.
3. The AD15:0 bus, or AD7:0 and A15:8 buses for an 8-bit device, drive to a zero (all low) at this time if Idle Mode is enabled. When Idle Mode is not enabled, the AD15:0 [AD7:0] bus either floats or drives previous write data, and A15:8 (8-bit device) continues to drive its previous value.
4. The A19:16 bus either drives zero (all low) or 8H (all low except A19/S6, which can be high if the previous bus cycle was a DMA or refresh operation). If either Idle or Powerdown Mode is enabled, the A19:16 bus drives zeros (all low) at phase 1 of T1. Otherwise, the previous value remains active.

A1088-0A

Figure 3-25. HALT Bus Cycle

3.5.5 Temporarily Exiting the HALT Bus State

A DMA request, refresh request or bus hold request causes the BIU to exit the HALT bus state temporarily. This can occur only when in the Active or Idle power management mode. The BIU returns to the HALT bus **state** after it completes the desired bus operation. However, the BIU **does not** execute another bus HALT **cycle** (i.e., ALE and bus cycle status are not regenerated). Figures 3-26, 3-27 and 3-28 illustrate how the BIU temporarily exits and then returns to the HALT bus state.

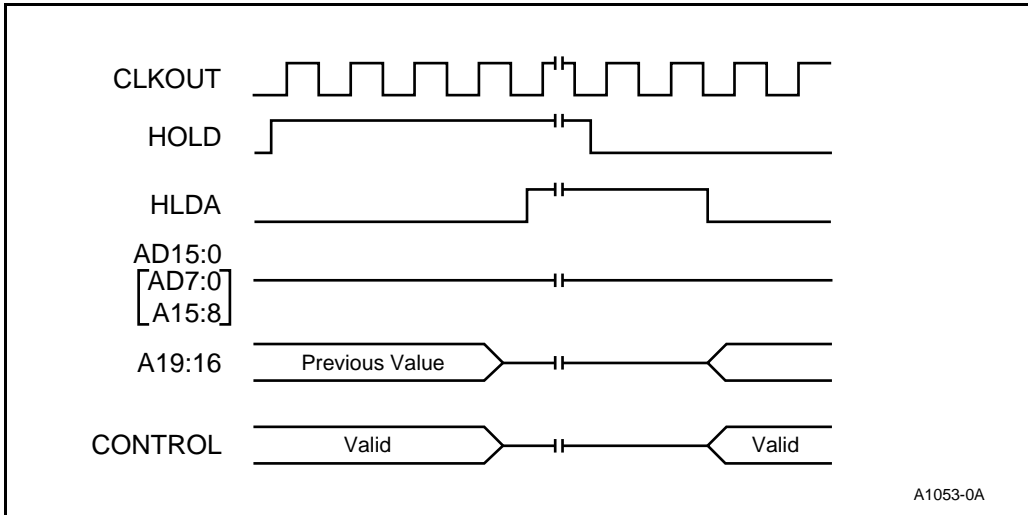

Figure 3-26. Returning to HALT After a HOLD/HLDA Bus Exchange

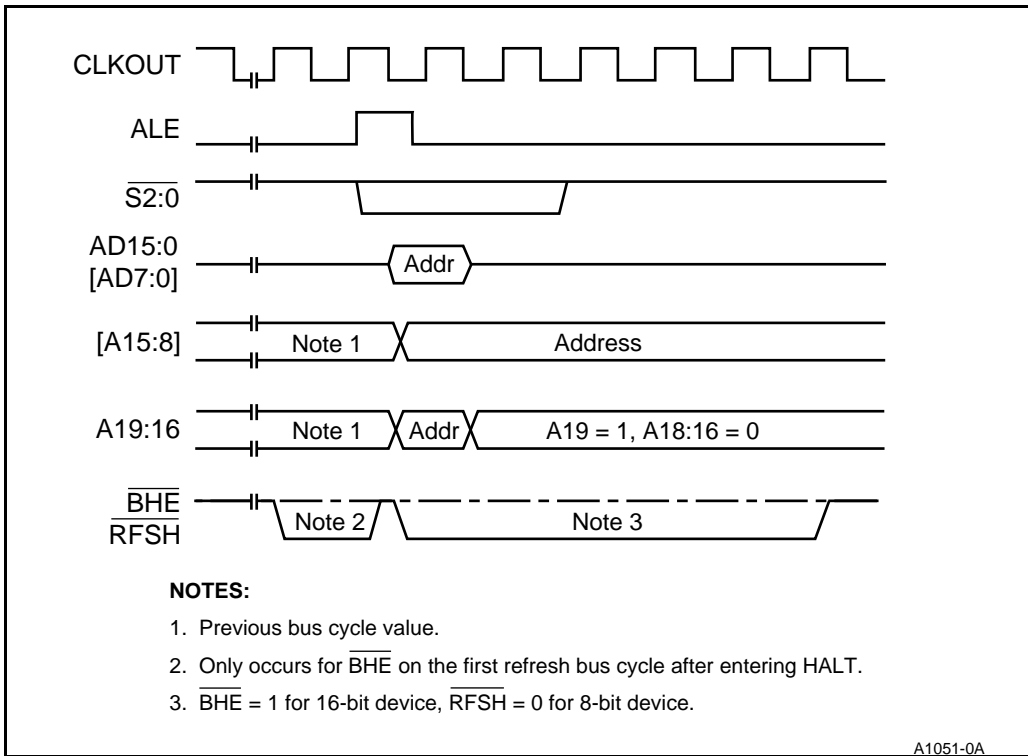

Figure 3-27. Returning to HALT After a Refresh Bus Cycle

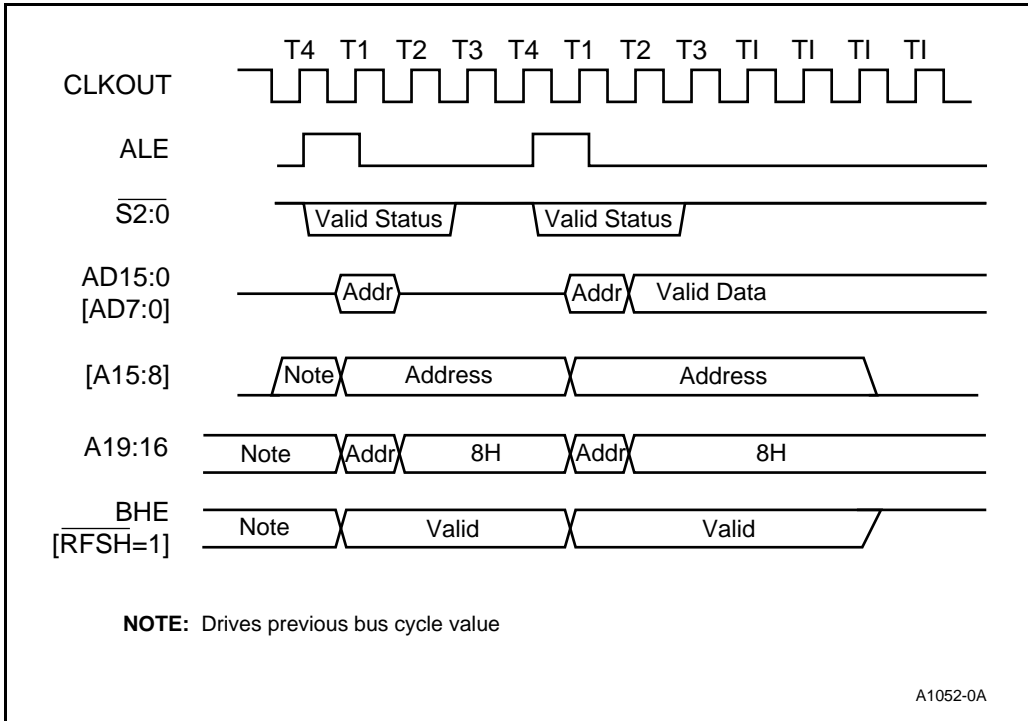

Figure 3-28. Returning to HALT After a DMA Bus Cycle

3.5.6 Exiting HALT

In Powerdown mode, only an NMI forces the BIU to exit the HALT bus state. In any other power management mode, either an NMI or any unmasked $INTn$ interrupt causes the BIU to exit HALT. The first bus operations to occur after exiting HALT are read cycles to reload the CS:IP registers. Figure 3-29 and Figure 3-30 show how the HALT bus state is exited when an NMI or $INTn$ occurs.

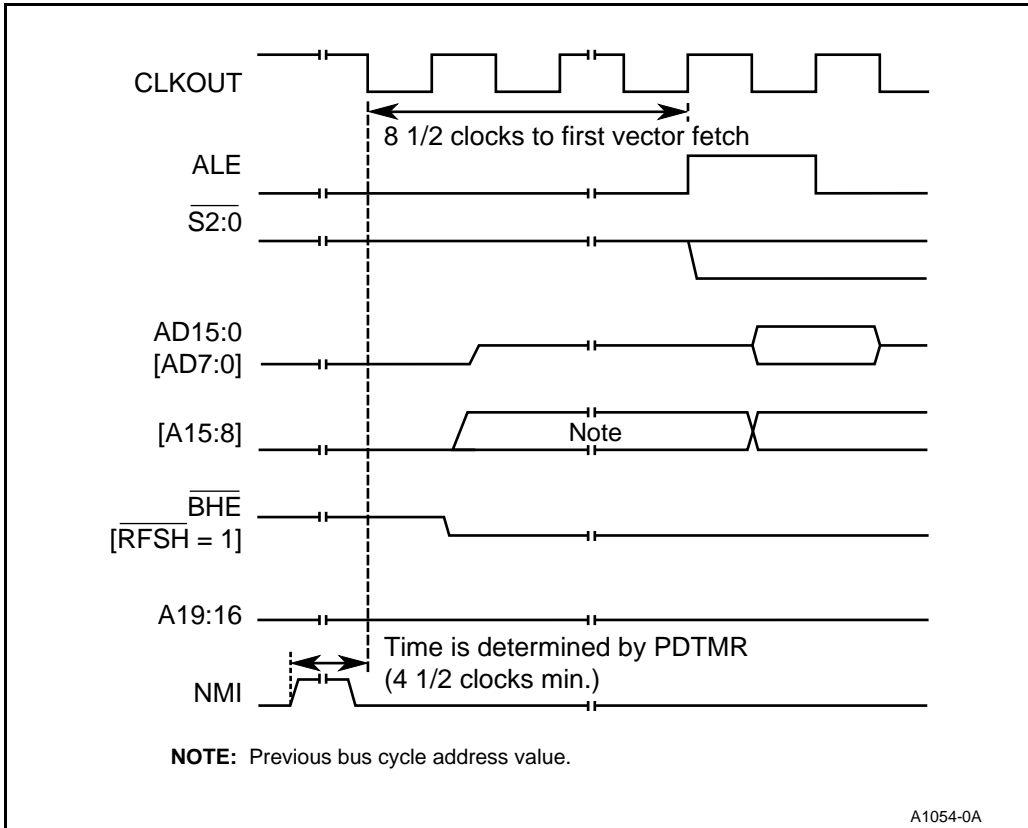

Figure 3-29. Exiting HALT (Powerdown Mode)

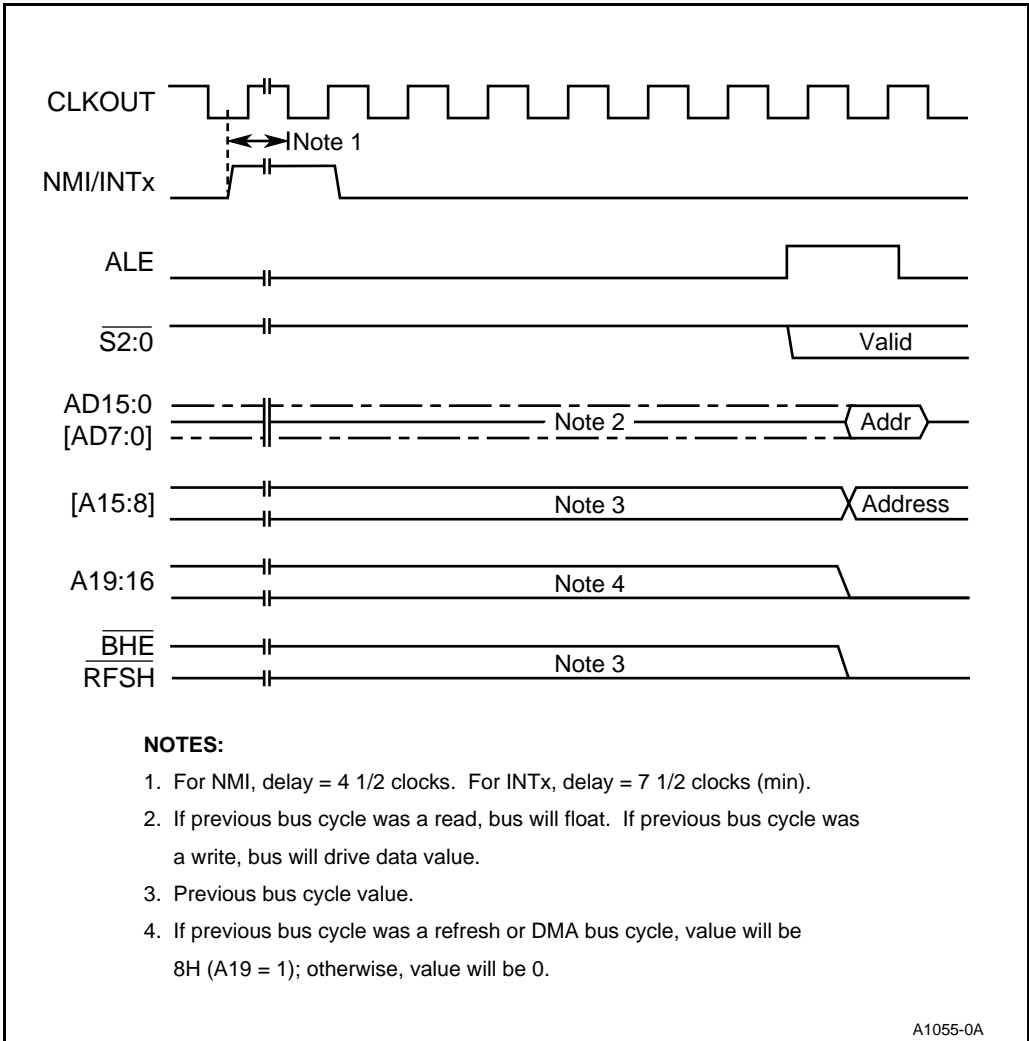

Figure 3-30. Exiting HALT (Active/Idle Mode)

3.6 SYSTEM DESIGN ALTERNATIVES

Most system designs require no signals other than those already provided by the BIU. However, heavily loaded bus conditions, slow memory or peripheral device performance and off-board device interfaces may not be supported directly without modifying the BIU interface. The following sections deal with topics to enhance or modify the operation of the BIU.

3.6.1 Buffering the Data Bus

The BIU generates two control signals, \overline{DEN} and DT/\overline{R} , to control bidirectional buffers or transceivers. The timing relationship of \overline{DEN} and DT/\overline{R} is shown in Figure 3-31. The following conditions require transceivers:

- The capacitive load on the address/data bus gets too large.
- The current load on the address/data bus exceeds device specifications.
- Additional V_{OL} and V_{OH} drive is required.
- A memory or I/O device cannot float its outputs in time to prevent bus contention, even at reset.

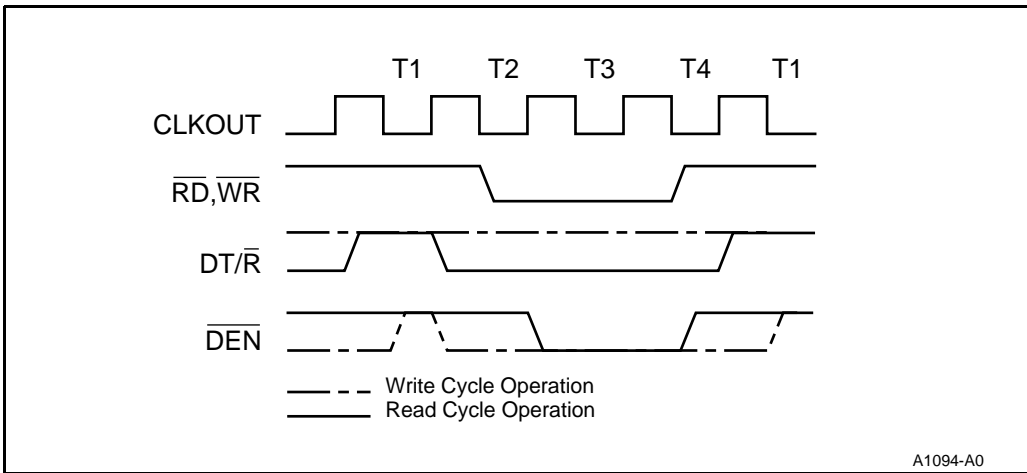

Figure 3-31. \overline{DEN} and DT/\overline{R} Timing Relationships

The circuit shown in Figure 3-32 illustrates how to use transceivers to buffer the address/data bus. The connection between the processor and the transceiver is known as the *local bus*. A connection between the transceiver and other memory or I/O devices is known as the *buffered bus*. A *fully buffered* system has **no** devices attached to the local bus. A *partially buffered* system has devices on both the local and buffered buses.

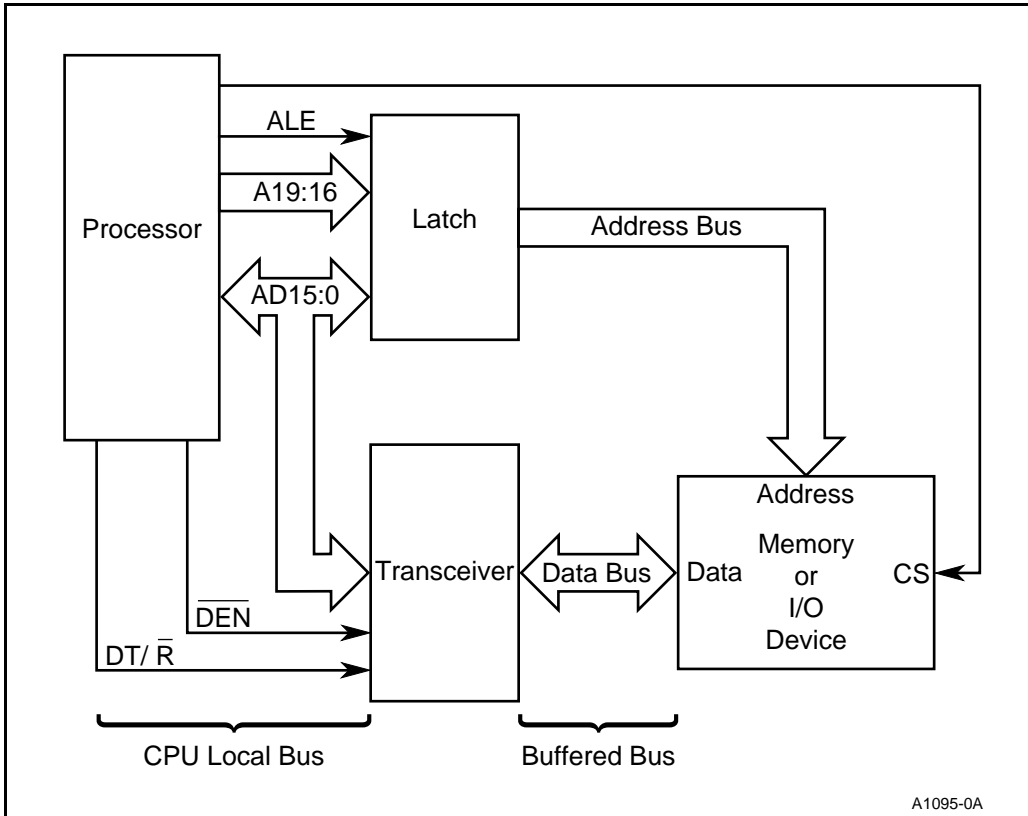
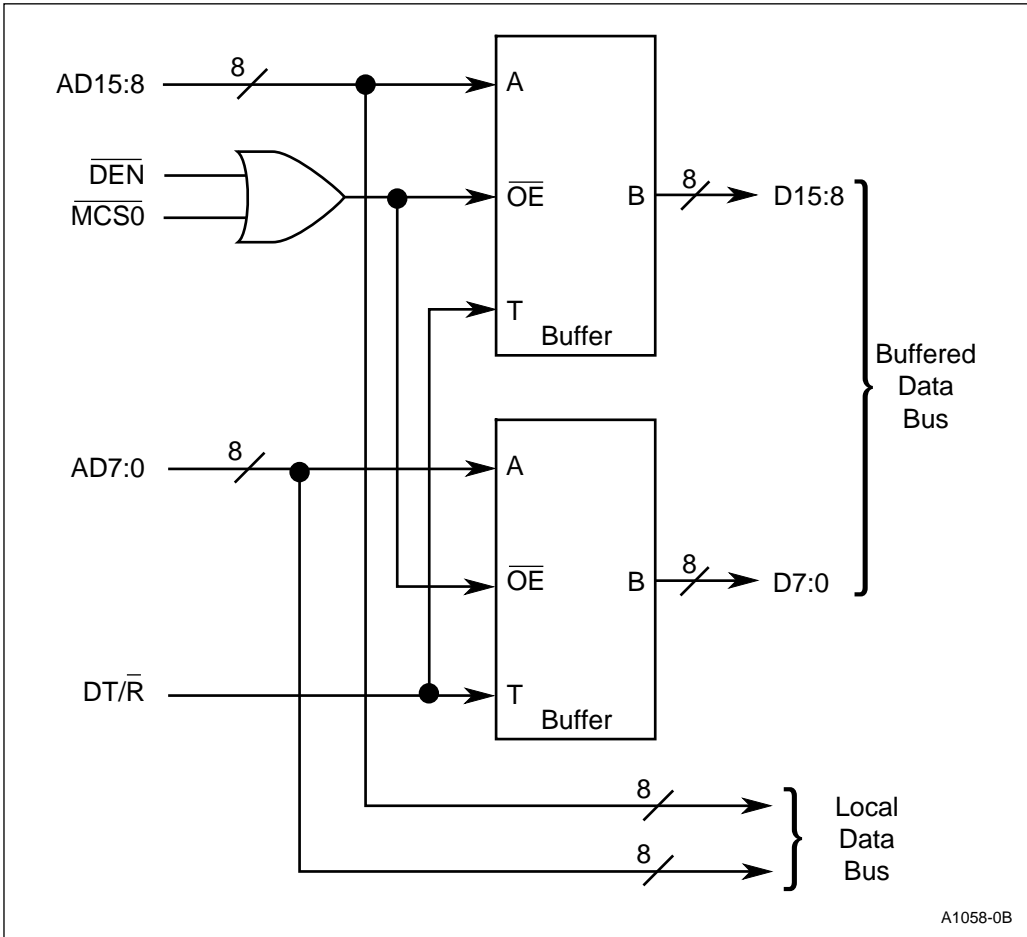

Figure 3-32. Buffered AD Bus System

In a fully buffered system, \overline{DEN} directly drives the transceiver output enable. A partially buffered system requires that \overline{DEN} be qualified with another signal to prevent the transceiver from going active for local bus accesses. Figure 3-33 illustrates how to use chip-selects to qualify \overline{DEN} .

DT/\overline{R} always connects directly to the transceiver. However, an inverter may be required if the polarity of DT/\overline{R} does not match the transceiver. DT/\overline{R} goes low (0) only for memory and I/O read, instruction prefetch and interrupt acknowledge bus cycles.



A1058-0B

Figure 3-33. Qualifying \overline{DEN} with Chip-Selects

3.6.2 Synchronizing Software and Hardware Events

The execution sequence of a program and hardware events occurring within a system are often asynchronous to each other. In some systems there may be a requirement to suspend program execution until an event (or events) occurs, then continue program execution.

One way to synchronize software execution with hardware events requires the use of interrupts. Executing a HALT instruction suspends program execution until an unmasked interrupt occurs. However, there is a delay associated with servicing the interrupt before program execution can proceed. Using the WAIT instruction removes the delay associated with servicing interrupts.

The WAIT instruction suspends program execution until one of two events occurs: an interrupt is generated, or the $\overline{\text{TEST}}$ input pin is sampled low. Unlike interrupts, the $\overline{\text{TEST}}$ input pin does not require that program execution be transferred to a new location (i.e., an interrupt routine is not executed). In processing the WAIT instruction, program execution remains suspended as long as $\overline{\text{TEST}}$ remains high (at least until an interrupt occurs). When $\overline{\text{TEST}}$ is sampled low, program execution resumes.

The $\overline{\text{TEST}}$ input and WAIT instruction provide a mechanism to delay program execution until a hardware event occurs, without having to absorb the delay associated with servicing an interrupt.

3.6.3 Using a Locked Bus

To address the problems of controlling accesses to shared resources, the BIU provides a hardware LOCK output. The execution of a LOCK prefix instruction activates the LOCK output.

$\overline{\text{LOCK}}$ goes active in phase 1 of T1 of the first bus cycle following execution of the LOCK prefix instruction. It remains active until phase 1 of T1 of the first bus cycle following the execution of the instruction following the LOCK prefix. To provide bus access control in multiprocessor systems, the LOCK signal should be incorporated into the system bus arbitration logic residing in the CPU.

During normal multiprocessor system operation, priority of the shared system bus is determined by the arbitration circuits on a cycle by cycle basis. As each CPU requires a transfer over the system bus, it requests access to the bus via its resident bus arbitration logic. When the CPU gains priority (determined by the system bus arbitration scheme and any associated logic), it takes control of the bus, performs its bus cycle and either maintains bus control, voluntarily releases the bus or is forced off the bus by the loss of priority.

The lock mechanism prevents the CPU from losing bus control (either voluntarily or by force) and guarantees that the CPU can execute multiple bus cycles without intervention and possible corruption of the data by another CPU. A classic use of the mechanism is the “TEST and SET semaphore,” during which a CPU must read from a shared memory location and return data to the location without allowing another CPU to reference the same location during the test and set operations.

Another application of $\overline{\text{LOCK}}$ for multiprocessor systems consists of a locked block move, which allows high speed message transfer from one CPU’s message buffer to another. During the locked instruction (i.e., while $\overline{\text{LOCK}}$ is active), a bus hold, DMA or refresh request is recorded, but is not acknowledged until completion of the locked instruction. However, $\overline{\text{LOCK}}$ has no effect on interrupts. As an example, a locked HALT instruction causes bus hold, DMA or refresh bus requests to be ignored, but still allows the CPU to exit the HALT state on an interrupt.

In general, prefix bytes (such as LOCK) are considered extensions of the instructions they precede. Interrupts, DMA requests and refresh requests that occur during execution of the prefix are not acknowledged until the instruction following the prefix completes (except for instructions that are servicing interrupts during their execution, such as HALT, WAIT and repeated string primitives). Note that multiple prefix bytes can precede an instruction.

Another example is a string primitive preceded by the repetition prefix (REP), which can be interrupted after each execution of the string primitive, even if the REP prefix is combined with the LOCK prefix. This prevents interrupts from being locked out during a block move or other repeated string operations. However, bus hold, DMA and refresh requests remain locked out until LOCK is removed (either when the block operation completes or after an interrupt occurs).

3.6.4 Using the Queue Status Signals

Older-generation devices require the queue status signals to interface with an 8087 math coprocessor. Newer devices do not require these signals because they use the 80187 math coprocessor, which has an I/O port interface similar to that of a peripheral device.

The queue status signals, QS0 and QS1, indicate the state of the internal queue (Table 3-7). Since the Execution Unit can remove information from the queue on any clock boundary, the queue status pins may change state on every phase 1 clock edge (Figure 3-34). Although these signals cannot be related to any specific T-state, the relationship between the queue status signals and BIU operation always remains the same for a given instruction sequence.

QS0 and QS1 are alternate functions of ALE and \overline{WR} , respectively. To enable QS0 and QS1, you must connect the \overline{RD} pin directly to ground. In this case, \overline{RD} , \overline{WR} and ALE are no longer available and must be generated by external hardware such as an 82C88 or a programmable logic device.

Table 3-7. Queue Status Signal Decoding

QS1	QS0	Queue Status
0	0	No queue operation occurred.
0	1	The first byte of a new instruction was removed from the queue.
1	0	The queue was reinitialized. All prefetch information was flushed; the BIU must begin prefetching new queue information.
1	1	A subsequent byte of an instruction was removed from the queue. The current instruction contains multiple opcode bytes or immediate data.

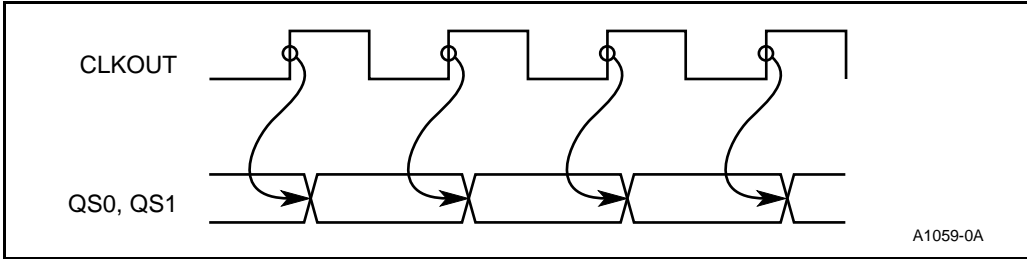

Figure 3-34. Queue Status Timing

3.7 MULTI-MASTER BUS SYSTEM DESIGNS

The BIU supports protocols for transferring control of the local bus between itself and other devices capable of acting as bus masters. To support such a protocol, the BIU uses a hold request input (HOLD) and a hold acknowledge output (HLDA) as bus transfer handshake signals. To gain control of the bus, a device asserts the HOLD input, then waits until the HLDA output goes active before driving the bus. After HLDA goes active, the requesting device can take control of the local bus and remains in control of the bus until HOLD is removed.

3.7.1 Entering Bus HOLD

In responding to the hold request input, the BIU floats the entire address and data bus, and many of the control signals. Figure 3-35 illustrates the timing sequence when acknowledging the hold request. Table 3-8 lists the states of the BIU pins when HLDA is asserted. All device pins not mentioned in Table 3-8 or shown in Figure 3-35 remain either active (e.g., CLKOUT and T1OUT) or inactive (e.g., \overline{UCS} and \overline{INTA}). Refer to the data sheet for specific details of pin functions during a bus hold.

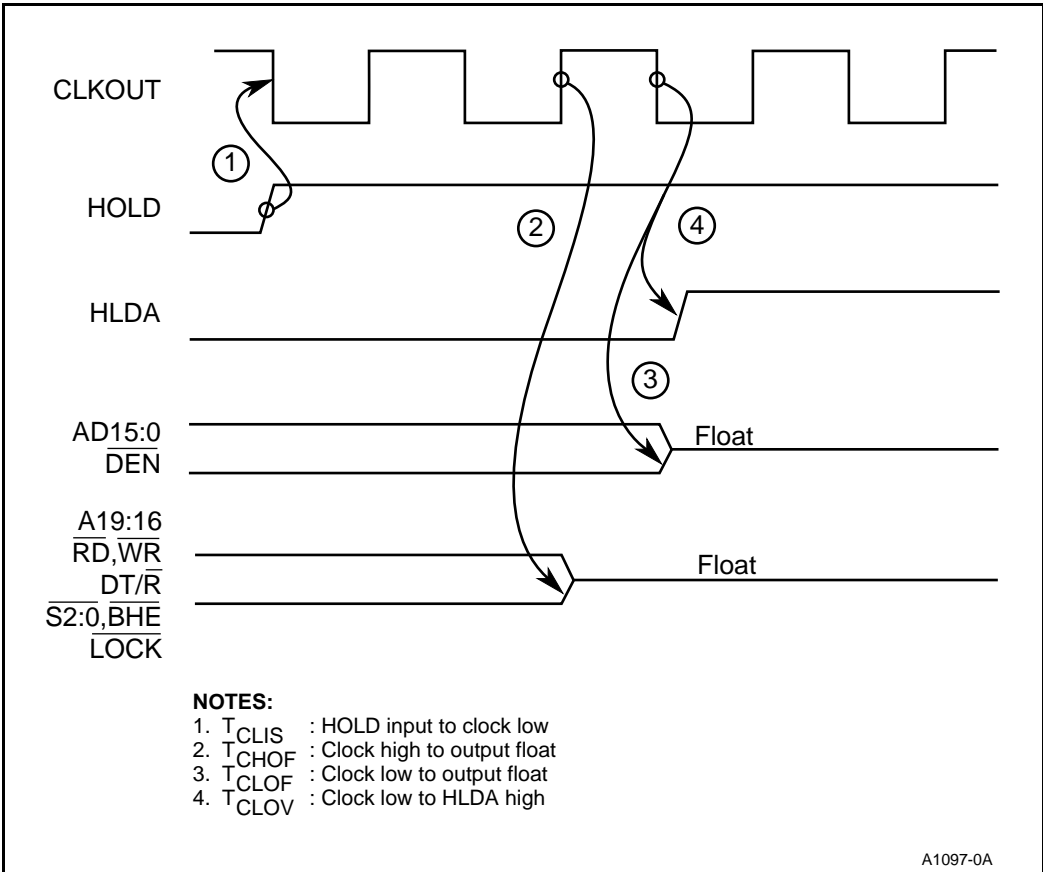

A1097-0A

Figure 3-35. Timing Sequence Entering HOLD

Table 3-8. Signal Condition Entering HOLD

Signal	HOLD Condition
A19:16, S2:0, RD, WR, DT/R, BHE (RFSH), LOCK	These signals float one-half clock before HLDA is generated (i.e., phase 2).
AD15:0 (16-bit), AD7:0 (8-bit), A15:8 (8-bit), DEN	These signals float during the same clock in which HLDA is generated (i.e., phase 1).

3.7.1.1 HOLD Bus Latency

The duration between the time that the external device asserts HOLD and the time that the BIU asserts HLDA is known as *bus latency*. In Figure 3-35, the two-clock delay between HOLD and HLDA represents the shortest bus latency. Normally this occurs only if the bus is idle or halted or if the bus hold request occurs just before the BIU begins another bus cycle.

The major factors that influence bus latency are listed below (in order from longest delay to shortest delay).

1. **Bus Not Ready** — As long as the bus remains not ready, a bus hold request cannot be serviced.
2. **Locked Bus Cycle** — As long as $\overline{\text{LOCK}}$ remains asserted, a bus hold request cannot be serviced. Performing a locked move string operation can take several thousands of clocks.
3. **Completion of Current Bus Cycle** — A bus hold request cannot be serviced until the current bus cycle completes. A bus hold request will not separate bus cycles required to move odd-aligned word data. Also, bus cycles with long wait states will delay the servicing of a bus hold request.
4. **Interrupt Acknowledge Bus Cycle** — A bus hold request is not serviced until after an $\overline{\text{INTA}}$ bus cycle has completed. An $\overline{\text{INTA}}$ bus cycle drives $\overline{\text{LOCK}}$ active.
5. **DMA and Refresh Bus Cycles** — A bus hold request is not serviced until after the DMA request or refresh bus cycle has completed. Refresh bus cycles have a higher priority than hold bus requests. A bus hold request cannot separate the bus cycles associated with a DMA transfer (worst case is an odd-aligned transfer, which takes four bus cycles to complete).

3.7.1.2 Refresh Operation During a Bus HOLD

Under normal operating conditions, once HLDA has been asserted it remains asserted until HOLD is removed. However, when a refresh bus request is generated, the HLDA output is removed (driven low) to signal the need for the BIU to regain control of the local bus. The BIU does not gain control of the bus until HOLD is removed. This procedure prevents the BIU from just arbitrarily regaining control of the bus.

Figure 3-36 shows the timing associated with the occurrence of a refresh request while HLDA is active. Note that HLDA can be as short as one clock in duration. This happens when a refresh request occurs just after HLDA is granted. A refresh request has higher priority than a bus hold request; therefore, when the two occur simultaneously, the refresh request occurs before HLDA becomes active.

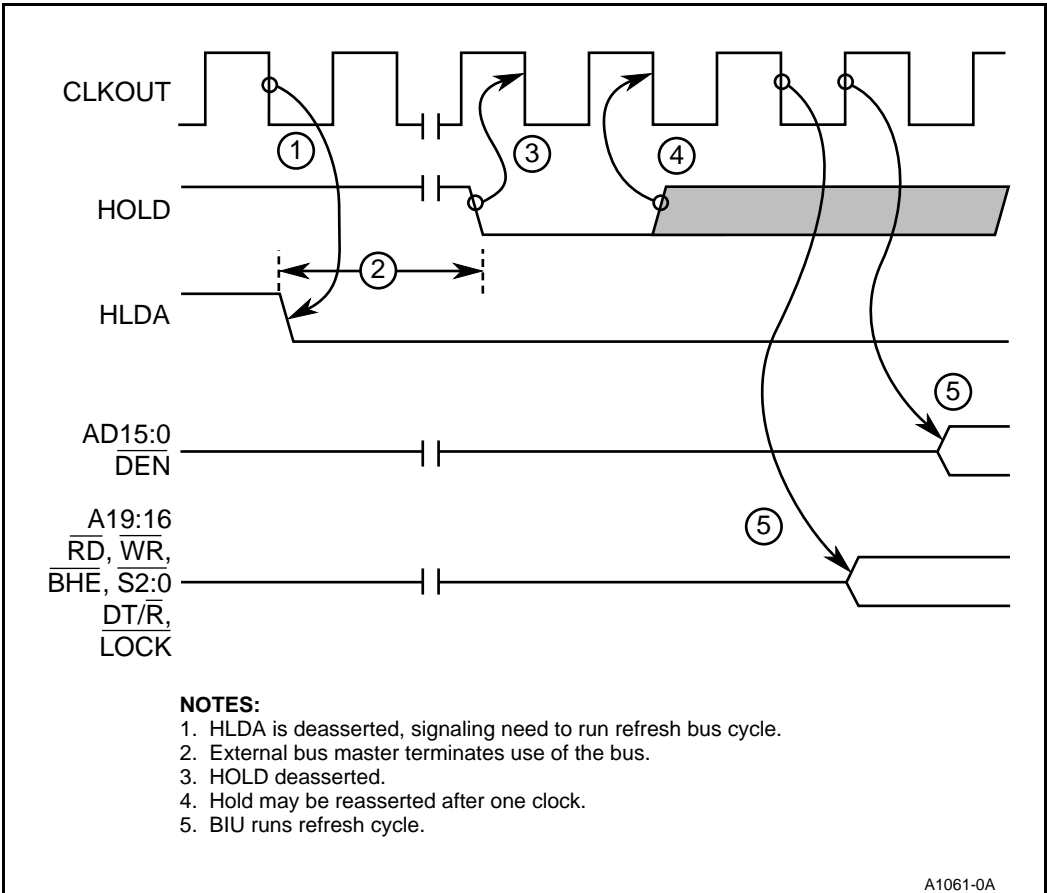

A1061-0A

Figure 3-36. Refresh Request During HOLD

The device requesting a bus hold must be able to detect a HLDA pulse that is one clock in duration. A bus lockup (hang) condition can result if the requesting device fails to detect the short HLDA pulse and continues to wait for HLDA to be asserted while the BIU waits for HOLD to be deasserted. The circuit shown in Figure 3-37 can be used to latch HLDA.

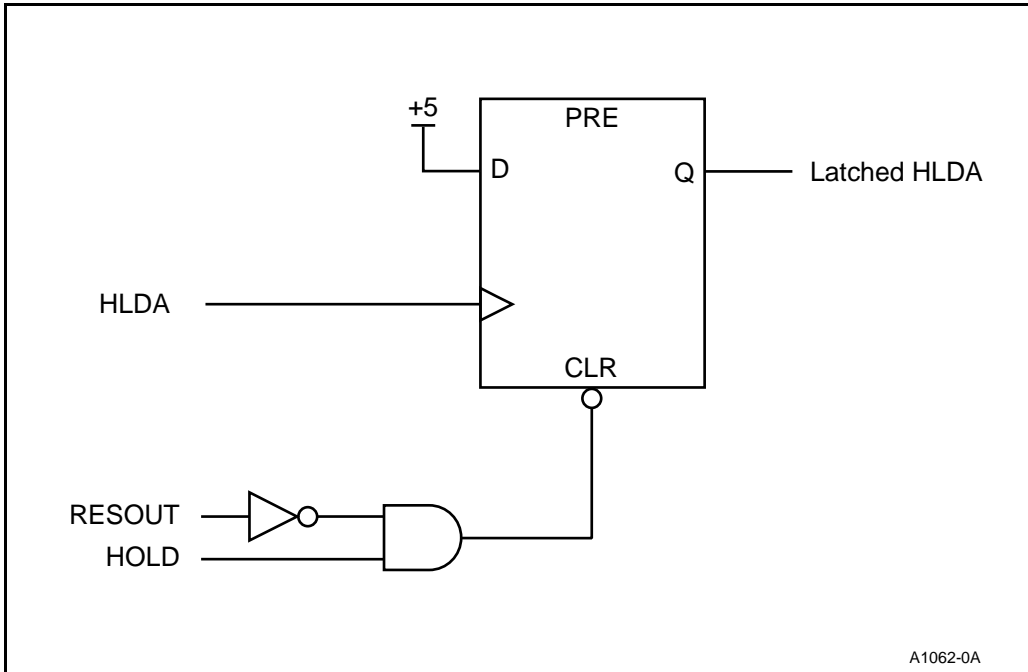

Figure 3-37. Latching HLDA

The removal of HOLD must be detected for at least one clock cycle to allow the BIU to regain the bus and execute a refresh bus cycle. Should HOLD go active before the refresh bus cycle is complete, the BIU will release the bus and generate HLDA.

3.7.2 Exiting HOLD

Figure 3-38 shows the timing associated with exiting the bus hold state. Normally a bus operation (e.g., an instruction prefetch) occurs just after HOLD is released. However, if no bus cycle is pending when leaving a bus hold state, the bus and associated control signals remain floating, if the system is in normal operating mode. (For signal states associated with Idle and Powerdown modes, see “Temporarily Exiting the HALT Bus State” on page 3-31).

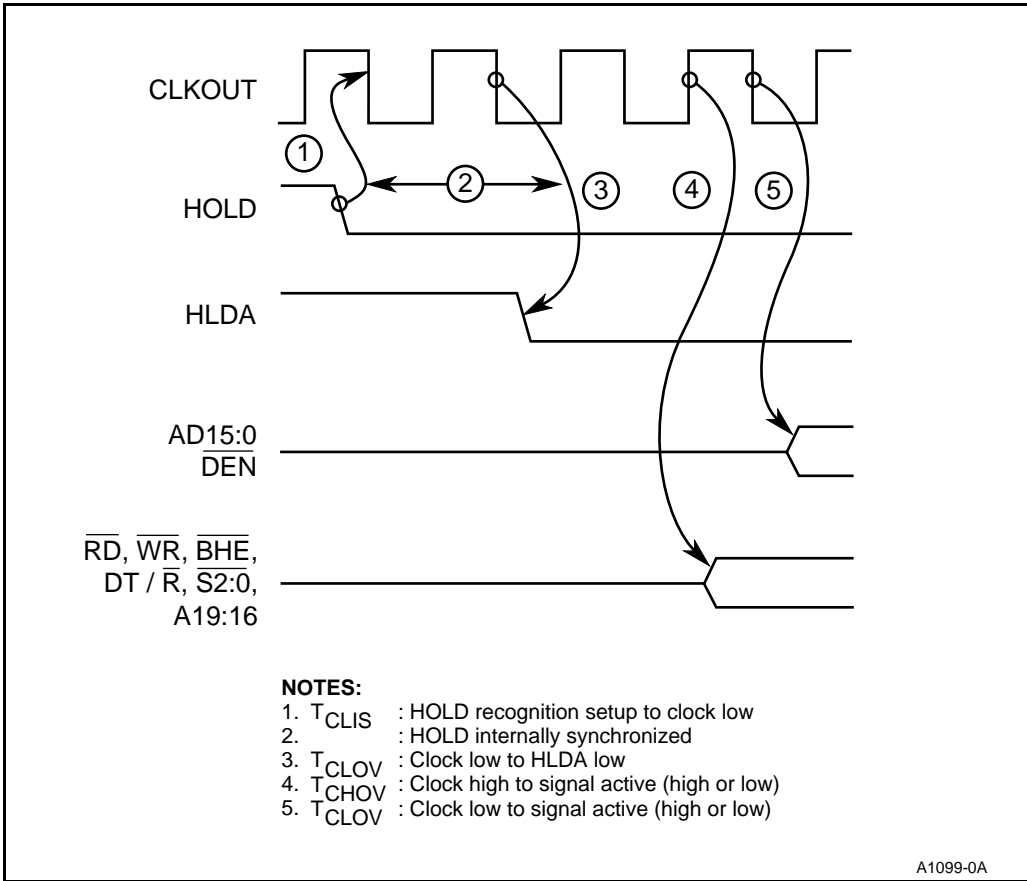

Figure 3-38. Exiting HOLD

3.8 BUS CYCLE PRIORITIES

The BIU arbitrates requests for bus cycles from the Execution Unit, the integrated peripherals (e.g., Interrupt Control Unit) and external bus masters (i.e., bus hold requests). The list below summarizes the priorities for all bus cycle requests (from highest to lowest).

1. Instruction execution read/write following a non-pipelined effective address calculation.
2. Refresh bus cycles.
3. Bus hold request.
4. Single step interrupt vectoring sequence.
5. Non-Maskable interrupt vectoring sequence.

6. Internal error (e.g., divide error, overflow) interrupt vectoring sequence.
7. Hardware (e.g., INT0, DMA) interrupt vectoring sequence.
8. 80C187 Math Coprocessor error interrupt vectoring sequence.
9. DMA bus cycles.
10. General instruction execution. This category includes read/write operations following a pipelined effective address calculation, vectoring sequences for software interrupts and numerics code execution. The following points apply to sequences of related execution cycles.
 - The second read/write cycle of an odd-addressed word operation is inseparable from the first bus cycle.
 - The second read/write cycle of an instruction with both load and store accesses (e.g., XCHG) can be separated from the first cycle by other bus cycles.
 - Successive bus cycles of string instructions (e.g., MOVS) can be separated by other bus cycles.
 - When a locked instruction begins, its associated bus cycles become the highest priority and cannot be separated (or preempted) until completed.
11. Bus cycles necessary to fill the prefetch queue.



4

Peripheral Control Block



CHAPTER 4

PERIPHERAL CONTROL BLOCK

All integrated peripherals in the 80C186 Modular Core family are controlled by sets of registers within an integrated Peripheral Control Block (PCB). The peripheral control registers are physically located in the peripheral devices they control, but they are addressed as a single block of registers. The Peripheral Control Block encompasses 256 contiguous bytes and can be located on any 256-byte boundary of memory or I/O space. The PCB Relocation Register, which is also located within the Peripheral Control Block, controls the location of the PCB.

4.1 PERIPHERAL CONTROL REGISTERS

Each of the integrated peripherals' control and status registers is located at a fixed offset above the programmed base location of the Peripheral Control Block (see Table 4-1). These registers are described in the chapters that cover the associated peripheral. "Accessing the Peripheral Control Block" on page 4-4 discusses how the registers are accessed and outlines considerations for reading and writing them.

4.2 PCB RELOCATION REGISTER

In addition to control registers for the integrated peripherals, the Peripheral Control Block contains the PCB Relocation Register (Figure 4-1). The Relocation Register is located at a fixed offset within the Peripheral Control Block (Table 4-1). If the Peripheral Control Block is moved, the Relocation Register also moves.

The PCB Relocation Register allows the Peripheral Control Block to be relocated to any 256-byte boundary within memory or I/O space. The Memory I/O bit (MEM) selects either memory space or I/O space, and the R19:8 bits specify the starting (base) address of the PCB. The remaining bit, Escape Trap (ET), controls access to the math coprocessor interface.

"Setting the PCB Base Location" on page 4-6 describes how to set the base location and outlines some restrictions on the Peripheral Control Block location.

Table 4-1. Peripheral Control Block

PCB Offset	Function	PCB Offset	Function	PCB Offset	Function	PCB Offset	Function
00H	Reserved	40H	Reserved	80H	Reserved	C0H	D0SRCL
02H	Reserved	42H	Reserved	82H	Reserved	C2H	D0SRCH
04H	Reserved	44H	Reserved	84H	Reserved	C4H	D0DSTL
06H	Reserved	46H	Reserved	86H	Reserved	C6H	D0DSTH
08H	Reserved	48H	Reserved	88H	Reserved	C8H	D0TC
0AH	Reserved	4AH	Reserved	8AH	Reserved	CAH	D0CON
0CH	Reserved	4CH	Reserved	8CH	Reserved	CCH	Reserved
0EH	Reserved	4EH	Reserved	8EH	Reserved	CEH	Reserved
10H	Reserved	50H	T0CNT	90H	Reserved	D0H	D1SRCL
12H	Reserved	52H	T0CMPA	92H	Reserved	D2H	D1SRCH
14H	Reserved	54H	T0CMPB	94H	Reserved	D4H	D1DSTL
16H	Reserved	56H	T0CON	96H	Reserved	D6H	D1DSTH
18H	Reserved	58H	T1CNT	98H	Reserved	D8H	D1TC
1AH	Reserved	5AH	T1CMPA	9AH	Reserved	DAH	D1CON
1CH	Reserved	5CH	T1CMPB	9CH	Reserved	DCH	Reserved
1EH	Reserved	5EH	T1CON	9EH	Reserved	DEH	Reserved
20H	Reserved	60H	T2CNT	A0H	UMCS	E0H	RFBASE
22H	EOI	62H	T2CMPA	A2H	LMCS	E2H	RFTIME
24H	POLL	64H	Reserved	A4H	PACS	E4H	RFCON
26H	POLLSTS	66H	T2CON	A6H	MMCS	E6H	Reserved
28H	IMASK	68H	Reserved	A8H	MPCS	E8H	Reserved
2AH	PRIMSK	6AH	Reserved	AAH	Reserved	EAH	Reserved
2CH	INSERTV	6CH	Reserved	ACH	Reserved	ECH	Reserved
2EH	REQST	6EH	Reserved	AEH	Reserved	EEH	Reserved
30H	INSTS	70H	Reserved	B0H	Reserved	F0H	PWRSAV
32H	TCUCON	72H	Reserved	B2H	Reserved	F2H	PWRCON
34H	DMA0CON	74H	Reserved	B4H	Reserved	F4H	Reserved
36H	DMA1CON	76H	Reserved	B6H	Reserved	F6H	STEPID
38H	I0CON	78H	Reserved	B8H	Reserved	F8H	Reserved
3AH	I1CON	7AH	Reserved	BAH	Reserved	FAH	Reserved
3CH	I2CON	7CH	Reserved	BCH	Reserved	FCH	Reserved
3EH	I3CON	7EH	Reserved	BEH	Reserved	FEH	RELREG

4.3 RESERVED LOCATIONS

Many locations within the Peripheral Control Block are not assigned to any peripheral. Unused locations are reserved. Reading from these locations yields an undefined result. If reserved registers are written (for example, during a block MOV instruction) they must be set to 0H.

NOTE

Failure to follow this guideline could result in incompatibilities with future 80C186 Modular Core family products.

4.4 ACCESSING THE PERIPHERAL CONTROL BLOCK

All communication between integrated peripherals and the Modular CPU Core occurs over a special bus, called the *F-Bus*, which always carries 16-bit data. The Peripheral Control Block, like all integrated peripherals, is always accessed 16 bits at a time.

4.4.1 Bus Cycles

The processor runs an external bus cycle for any memory or I/O cycle accessing a location within the Peripheral Control Block. Address, data and control information is driven on the external pins as with an ordinary bus cycle. Information returned by an external device is ignored, even if the access does not correspond to the location of an integrated peripheral control register. This is also true for the 80C188 Modular Core family, except that word accesses made to integrated registers are performed in two bus cycles.

4.4.2 READY Signals and Wait States

The processor generates an internal READY signal whenever an integrated peripheral is accessed. External READY is ignored. READY is also generated if an access is made to a location within the Peripheral Control Block that does not correspond to an integrated peripheral control register. For accesses to timer control and counting registers, the processor inserts one wait state. This is required to properly multiplex processor and counter element accesses to the timer control registers. For accesses to the remaining locations in the Peripheral Control Block, the processor does not insert wait states.

4.4.3 F-Bus Operation

The F-Bus functions differently than the external data bus for byte and word accesses. All write transfers on the F-Bus occur as words, regardless of how they are encoded. For example, the instruction `OUT DX, AL` (`DX` is even) will write the entire `AX` register to the Peripheral Control Block register at location `[DX]`. If `DX` were an odd location, `AL` would be placed in `[DX]` and `AH` would be placed at `[DX-1]`. A word operation to an odd address would write `[DX]` and `[DX-1]` with `AL` and `AH`, respectively. This differs from normal external bus operation where unaligned word writes modify `[DX]` and `[DX+1]`. In summary, do not use odd-aligned byte or word writes to the PCB.

Aligned word reads work normally. Unaligned word reads work differently. For example, `IN AX, DX` (`DX` is odd) will transfer `[DX]` into `AL` and `[DX-1]` into `AH`. Byte reads from even or odd addresses work normally, but only a byte will be read. For example, `IN AL, DX` will **not** transfer `[DX]` into `AX` (only `AL` is modified).

No problems will arise if the following recommendations are adhered to.

Word reads	Aligned word reads of the PCB work normally. Access only even-aligned words with <code>IN AX, DX</code> or <code>MOV word register, even PCB address</code> .
Byte reads	Byte reads of the PCB work normally. Beware of reading word-wide PCB registers that may change value between successive reads (e.g., timer count value).
Word writes	<p>Always write even-aligned words to the PCB. Writing an odd-aligned word will give unexpected results.</p> <p>For the 80C186 Modular Core, use either</p> <ul style="list-style-type: none"> – <code>OUT DX, AX</code> or – <code>OUT DX, AL</code> or – <code>MOV even PCB address, word register</code>. <p>For the 80C188 Modular Core, using <code>OUT DX, AX</code> will perform an unnecessary bus cycle and is not recommended. Use either</p> <ul style="list-style-type: none"> – <code>OUT DX, AL</code> or – <code>MOV even-aligned byte PCB address, byte register low byte</code>.
Byte writes	Always use even-aligned byte writes to the PCB. Even-aligned byte writes will modify the entire word PCB location. Do not perform unaligned byte writes to the PCB.

4.4.3.1 Writing the PCB Relocation Register

Whenever mapping the Peripheral Control Block to another location, the user should program the Relocation Register with a **byte write** (i.e., OUT DX, AL). Internally, the Relocation Register is written with 16 bits of the AX register, while externally the Bus Interface Unit runs a single 8-bit bus cycle. If a word instruction (i.e., OUT DX, AX) is used with an 80C188 Modular Core family member, the Relocation Register is written on the first bus cycle. The Bus Interface Unit then runs an unnecessary second bus cycle. The address of the second bus cycle is no longer within the control block, since the Peripheral Control Block was moved on the first cycle. External READY must now be generated to complete the cycle. For this reason, we recommend byte operations for the Relocation Register.

4.4.3.2 Accessing the Peripheral Control Registers

Byte instructions should be used for the registers in the Peripheral Control Block of an 80C188 Modular Core family member. This requires half the bus cycles of word operations. Byte operations are valid only for even-addressed writes to the Peripheral Control Block. A word read (e.g., IN AX, DX) must be performed to read a 16-bit Peripheral Control Block register when possible.

4.4.3.3 Accessing Reserved Locations

Unused locations are reserved. If a write is made to these locations, a bus cycle occurs, but data is not stored. If a subsequent read is made to the same location, the value written is not read back. If reserved registers are written (for example, during a block MOV instruction) they must be cleared to 0H.

NOTE

Failure to follow this guideline could result in incompatibilities with future 80C186 Modular Core family products.

4.5 SETTING THE PCB BASE LOCATION

Upon reset, the PCB Relocation Register (see Figure 4-1 on page 4-2) contains the value 00FFH, which causes the Peripheral Control Block to be located at the top of I/O space (0FF00H to 0FFFFH). Writing the PCB Relocation Register allows the user to change that location.

As an example, to relocate the Peripheral Control Block to the memory range 10000-100FFH, the user would program the PCB Relocation Register with the value 1100H. Since the Relocation Register is part of the Peripheral Control Block, it relocates to word 10000H plus its fixed offset.

NOTE

Due to an internal condition, external ready is ignored if the device is configured in Cascade mode and the Peripheral Control Block (PCB) is located at 0000H in I/O space. In this case, wait states **cannot** be added to interrupt acknowledge bus cycles. However, you **can** add wait states to interrupt acknowledge cycles if the PCB is located at any other address.

4.5.1 Considerations for the 80C187 Math Coprocessor Interface

Systems using the 80C187 math coprocessor interface must **not** relocate the Peripheral Control Block to location 0000H in I/O space. The 80C187 interface uses I/O locations 0F8H through 0FFH. If the Peripheral Control Block resides in these locations, the processor communicates with the Peripheral Control Block, **not** the 80C187 interface circuitry.

NOTE

If the PCB is located at 0000H in I/O space and access to the math coprocessor interface is enabled (the Escape Trap bit is clear), a numerics (ESC) instruction causes indeterminate system operation.

Since the 8-bit bus version of the device does not support the 80C187, it automatically traps an ESC instruction to the Type 7 interrupt, regardless of the state of the Escape Trap (ET) bit.

For details on the math coprocessor interface, see Chapter 11, “Math Coprocessing.”



5

Clock Generation and Power Management



CHAPTER 5

CLOCK GENERATION AND POWER MANAGEMENT

The clock generation and distribution circuits provide uniform clock signals for the Execution Unit, the Bus Interface Unit and all integrated peripherals. The 80C186 Modular Core Family processors have additional logic that controls the clock signals to provide power management functions.

5.1 CLOCK GENERATION

The clock generation circuit (Figure 5-1) includes a crystal oscillator, a divide-by-two counter, power-save, powerdown, idle, and reset circuitry. See “Power Management” on page 5-10 for a discussion of power management options.

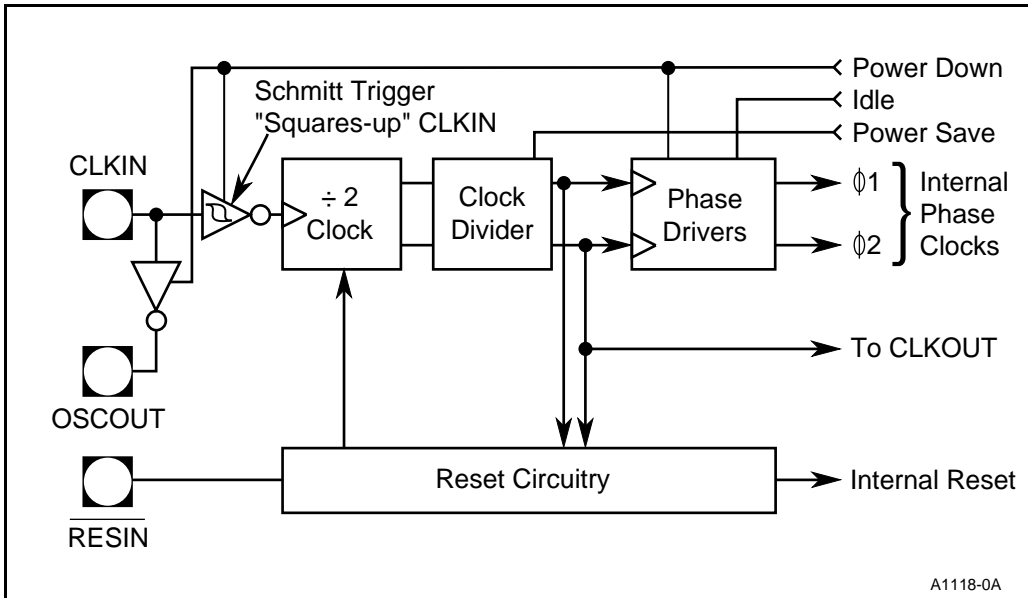

Figure 5-1. Clock Generator

5.1.1 Crystal Oscillator

The internal oscillator is a parallel resonant Pierce oscillator, a specific form of the common phase shift oscillator.

5.1.1.1 Oscillator Operation

A phase shift oscillator operates through positive feedback, where a non-inverted, amplified version of the input connects back to the input. A 360° phase shift around the loop will sustain the feedback in the oscillator. The on-chip inverter provides a 180° phase shift. The combination of the inverter’s output impedance and the first load capacitor (see Figure 5-2) provides another 90° phase shift. At resonance, the crystal becomes primarily resistive. The combination of the crystal and the second load capacitor provides the final 90° phase shift. Above and below resonance, the crystal is reactive and forces the oscillator back toward the crystal’s nominal frequency.

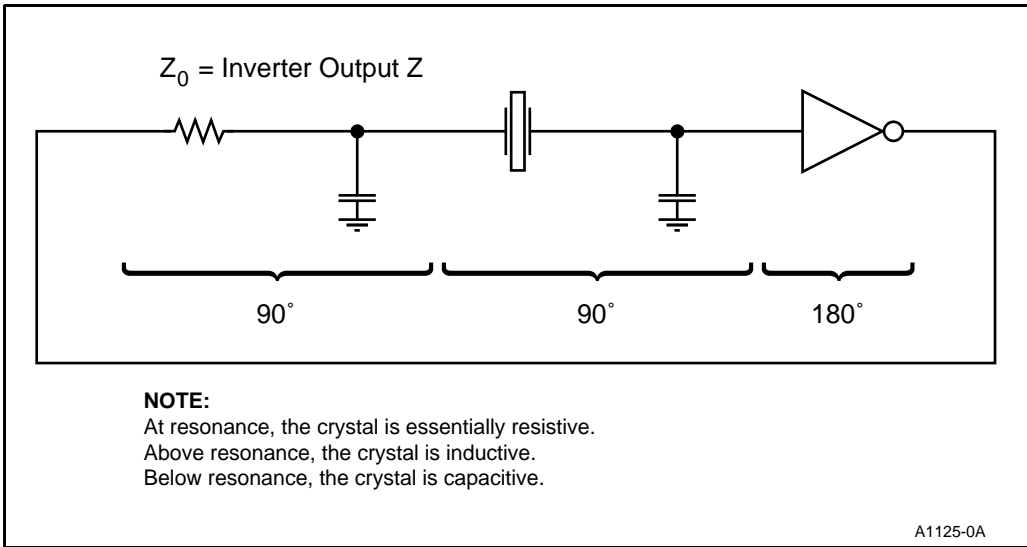

Figure 5-2. Ideal Operation of Pierce Oscillator

Figure 5-3 shows the actual microprocessor crystal connections. For low frequencies, crystal vendors offer fundamental mode crystals. At higher frequencies, a third overtone crystal is the only choice. The external capacitors, C_{X1} at CLKIN and C_{X2} at OSCOUT, together with stray capacitance, form the load. A third overtone crystal requires an additional inductor L_1 and capacitor C_1 to select the third overtone frequency and reject the fundamental frequency. See “Selecting Crystals” on page 5-5 for a more detailed discussion of crystal vibration modes.

Choose C_1 and L_1 component values in the third overtone crystal circuit to satisfy the following conditions:

- The LC components form an equivalent series resonant circuit at a frequency below the fundamental frequency. This criterion makes the circuit inductive at the fundamental frequency. The inductive circuit cannot make the 90° phase shift and oscillations do not take place.
- The LC components form an equivalent parallel resonant circuit at a frequency about halfway between the fundamental frequency and the third overtone frequency. This criterion makes the circuit capacitive at the third overtone frequency, necessary for oscillation.
- The two capacitors and inductor at OSCOUT, plus some stray capacitance, approximately equal the 20 pF load capacitor, C_{X2} , used alone in the fundamental mode circuit.

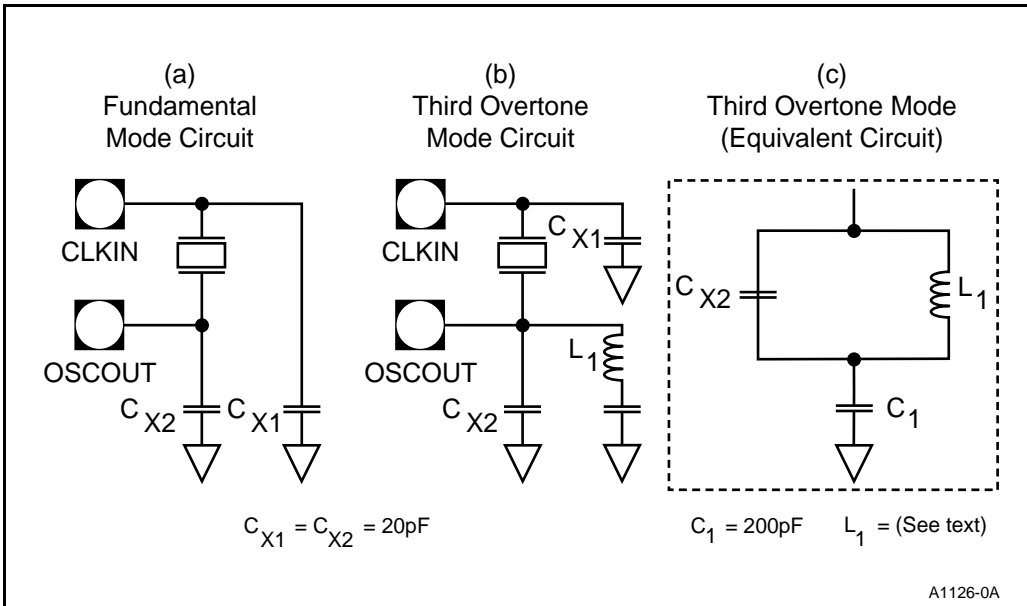

Figure 5-3. Crystal Connections to Microprocessor

Choosing C_1 as 200 pF (at least 10 times the value of the load capacitor) simplifies the circuit analysis. At the series resonance, the capacitance connected to L_1 is 200 pF in series with 20 pF. The equivalent capacitance is still about 20 pF and the equation in Figure 5-4(a) yields the series resonant frequency.

To examine the parallel resonant frequency, refer to Figure 5-3(c), an equivalent circuit to Figure 5-3(b). The capacitance connected to L_1 is 200 pF in parallel with 20 pF. The equivalent capacitance is still about 200 pF (within 10%) and the equation in Figure 5-4(a) now yields the parallel resonant frequency.

<p>(a) Series or Parallel Resonant Frequency</p> $f = \frac{1}{2\pi\sqrt{L_1 C_1}}$	<p>(b) Equivalent Capacitance</p> $C_{eq} = \frac{\omega^2 C_1 C_{x2} L_1 - C_1 - C_{x2}}{\omega^2 C_1 L_1 - 1}$
---	--

Figure 5-4. Equations for Crystal Calculations

The equation in Figure 5-4(b) yields the equivalent capacitance C_{eq} at the operation frequency. The desired operation frequency is the third overtone frequency marked on the crystal. Optimizing equations for the above three criteria yields Table 5-1. This table shows suggested standard inductor values for various processor frequencies. The equivalent capacitance is about 15 pF.

Table 5-1. Suggested Values for Inductor L_1 in Third Overtone Oscillator Circuit

CLKOUT Frequency (MHz)	Third-Overtone Crystal Frequency (MHz)	Inductor L_1 Values (μ H)
13.04	26.08	6.8, 8.2, 10.0
16	32	3.9, 4.7, 5.6
20	40	2.2, 2.7, 3.3

5.1.1.2 Selecting Crystals

When specifying crystals, consider these parameters:

- **Resonance and Load Capacitance** — Crystals carry a parallel or series resonance specification. The two types do not differ in construction, just in test conditions and expected circuit application. Parallel resonant crystals carry a test load specification, with typical load capacitance values of 15, 18 or 22 pF. Series resonant crystals do not carry a load capacitance specification. You may use a series resonant crystal with the microprocessor, even though the circuit is parallel resonant. However, it will vibrate at a frequency slightly (on the order of 0.1%) higher than its calibration frequency.
- **Vibration Mode** — The vibration mode is either fundamental or third overtone. Crystal thickness varies inversely with frequency. Vendors furnish third or higher overtone crystals to avoid manufacturing very thin, fragile quartz crystal elements. At a given frequency, an overtone crystal is thicker and more rugged than its fundamental mode counterpart. Below 20 MHz, most crystals are fundamental mode. In the 20 to 32 MHz range, you can purchase both modes. You must know the vibration mode to know whether to add the LC circuit at OSCOUT.
- **Equivalent Series Resistance (ESR)** — ESR is proportional to crystal thickness, inversely proportional to frequency. A lower value gives a faster startup time, but the specification is usually not important in microprocessor applications.
- **Shunt Capacitance** — A lower value reduces ESR, but typical values such as 7 pF will work fine.
- **Drive Level** — Specifies the maximum power dissipation for which the manufacturer calibrated the crystal. It is proportional to ESR, frequency, load and V_{CC} . Disregard this specification unless you use a third overtone crystal whose ESR and frequency will be relatively high. Several crystal manufacturers stock a standard microprocessor crystal line. Specifying a “microprocessor grade” crystal should ensure that the rated drive level is a couple of milliwatts with 5-volt operation.
- **Temperature Range** — Specifies an operating range over which the frequency will not vary beyond a stated limit. Specify the temperature range to match the microprocessor temperature range.
- **Tolerance** — The allowable frequency deviation at a particular calibration temperature, usually 25° C. Quartz crystals are more accurate than microprocessor applications call for; do not pay for a tighter specification than you need. Vendors quote frequency tolerance in percentage or parts per million (ppm). Standard microprocessor crystals typically have a frequency tolerance of 0.01% (100 ppm). If you use these crystals, you can usually disregard all the other specifications; these crystals are ideal for the 80C186 Modular Core family.

An important consideration when using crystals is that the oscillator **start** correctly over the voltage and temperature ranges expected in operation. Observe oscillator startup in the laboratory. Varying the load capacitors (within about $\pm 50\%$) can optimize startup characteristics versus stability. In your experiments, consider stray capacitance and scope loading effects.

For help in selecting external oscillator components for unusual circumstances, count on the crystal manufacturer as your best resource. Using low-cost ceramic resonators in place of crystals is possible if your application will tolerate less precise frequencies.

5.1.2 Using an External Oscillator

The microprocessor's on-board clock oscillator allows the use of a relatively low cost crystal. However, the designer may also use a "canned oscillator" or other external frequency source. Connect the external frequency input (EFI) signal directly to the oscillator CLKIN input. Leave OSCOUT unconnected. This oscillator input drives the internal divide-by-two counter directly, generating the CPU clock signals. The external frequency input can have practically any duty cycle, provided it meets the minimum high and low times stated in the data sheet. Selecting an external clock oscillator is more straightforward than selecting a crystal.

5.1.3 Output from the Clock Generator

The crystal oscillator output drives a divide-by-two circuit, generating a 50% duty cycle clock for the processor's integrated components. All processor timings refer to this clock, available externally at the CLKOUT pin. CLKOUT changes state on the high-to-low transition of the CLKIN signal, even during reset and bus hold. CLKOUT is also available during Idle mode, but not during Powerdown mode. (See "Idle Mode" on page 5-11 and "Powerdown Mode" on page 5-16.)

In a CMOS circuit, significant current flows only during logic level transitions. Since the microprocessor consists mostly of clocked circuitry, the clock distribution is the basis of power management.

5.1.4 Reset and Clock Synchronization

The clock generator provides a system reset signal (RESOUT). The $\overline{\text{RESIN}}$ input generates RESOUT and the clock generator synchronizes it to the CLKOUT signal.

A Schmitt trigger in the $\overline{\text{RESIN}}$ input ensures that the switch point for a low-to-high transition is greater than the switch point for a high-to-low transition. The processor must remain in reset a minimum of 4 CLKOUT cycles after V_{CC} and CLKOUT stabilize. The hysteresis allows a simple RC circuit to drive the $\overline{\text{RESIN}}$ input (see Figure 5-5). Typical applications can use about 100 milliseconds as an RC time constant.

Reset may be either cold (power-up) or warm. Figure 5-6 illustrates a cold reset. Assert the $\overline{\text{RESIN}}$ input during power supply and oscillator startup. The processor's pins assume their reset pin states a maximum of 28 CLKIN periods after CLKIN and V_{CC} stabilize. Assert $\overline{\text{RESIN}}$ 4 additional CLKIN periods after the device pins assume their reset states.

Applying $\overline{\text{RESIN}}$ when the device is running constitutes a warm reset (see Figure 5-7). In this case, assert $\overline{\text{RESIN}}$ for at least 4 CLKOUT periods. The device pins will assume their reset states on the second falling edge of CLKIN following the assertion of $\overline{\text{RESIN}}$.

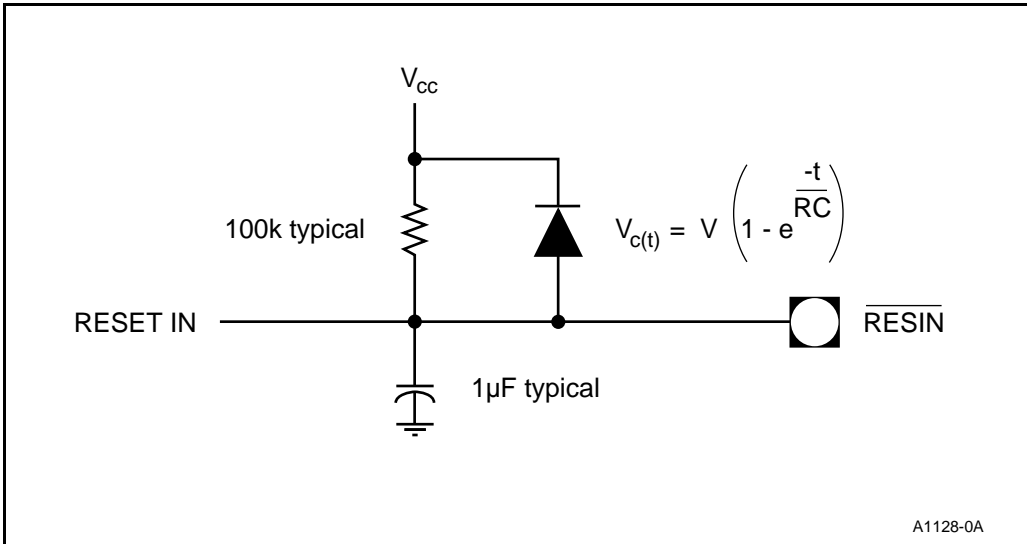

Figure 5-5. Simple RC Circuit for Powerup Reset

The processor exits reset identically in both cases. The falling $\overline{\text{RESIN}}$ edge generates an internal RESYNC pulse (see Figure 5-8), resynchronizing the divide-by-two internal phase clock. The clock generator samples $\overline{\text{RESIN}}$ on the falling CLKIN edge. If $\overline{\text{RESIN}}$ is sampled high while CLKOUT is high, the processor forces CLKOUT low for the next two CLKIN cycles. The clock essentially “skips a beat” to synchronize the internal phases. If $\overline{\text{RESIN}}$ is sampled high while CLKOUT is low, CLKOUT is already in phase.

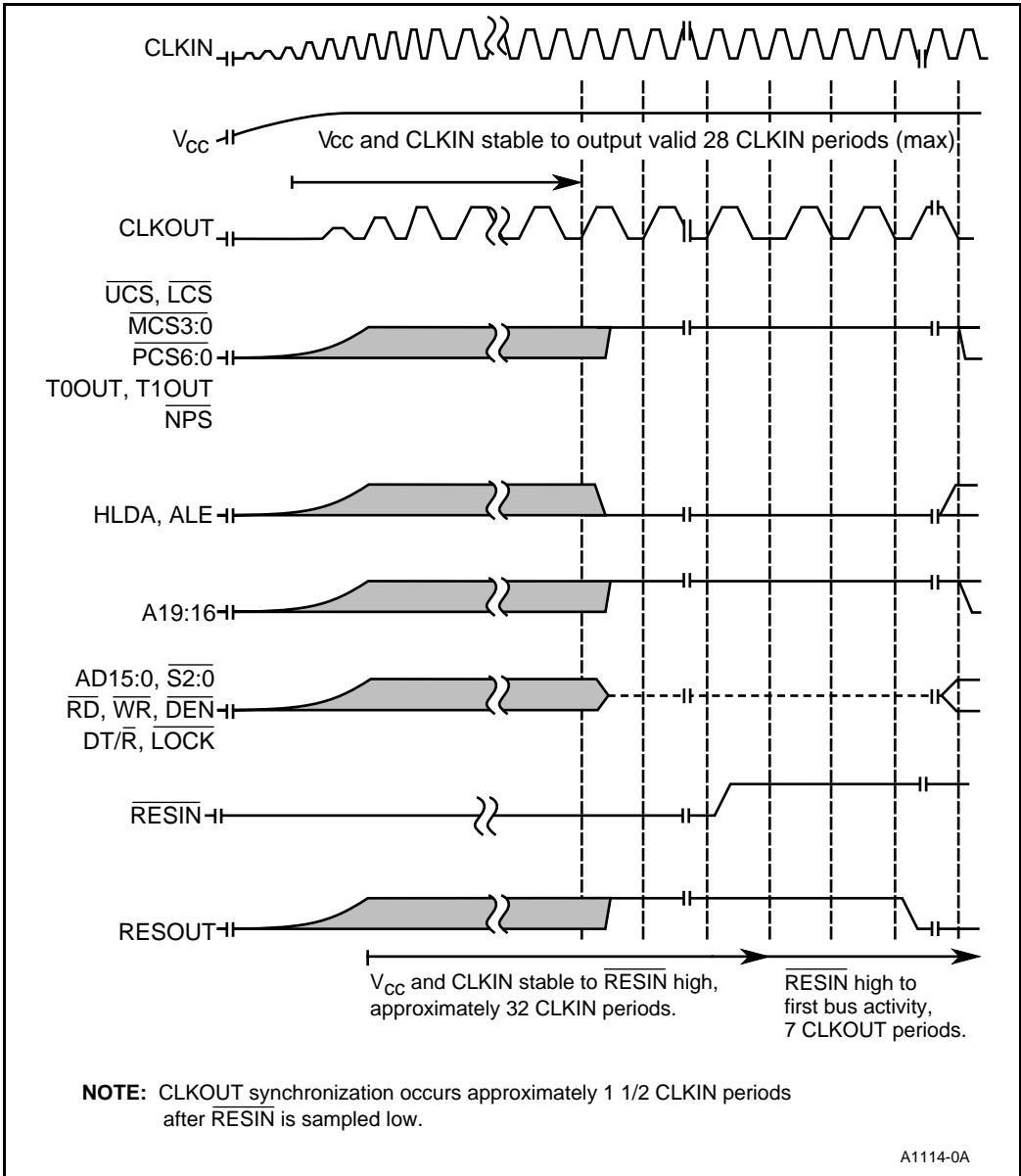

Figure 5-6. Cold Reset Waveform

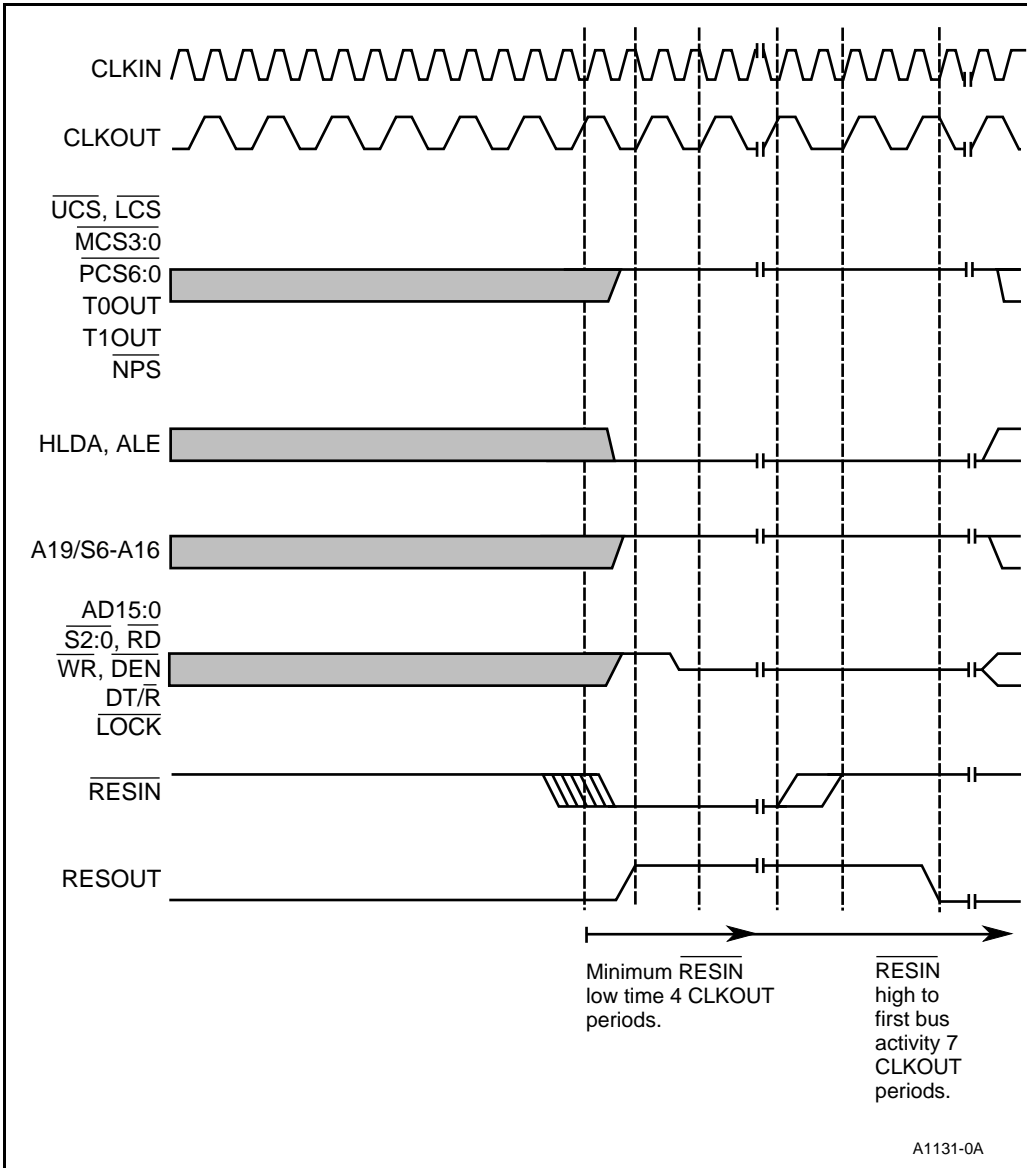

Figure 5-7. Warm Reset Waveform

At the second falling CLKOUT edge after sampling $\overline{\text{RESIN}}$ inactive, the processor deasserts RESOUT. Bus activity starts $6\frac{1}{2}$ CLKOUT periods after recognition of $\overline{\text{RESIN}}$ in the logic high state. If an alternate bus master asserts HOLD during reset, the processor immediately asserts HLDA and will not prefetch instructions.

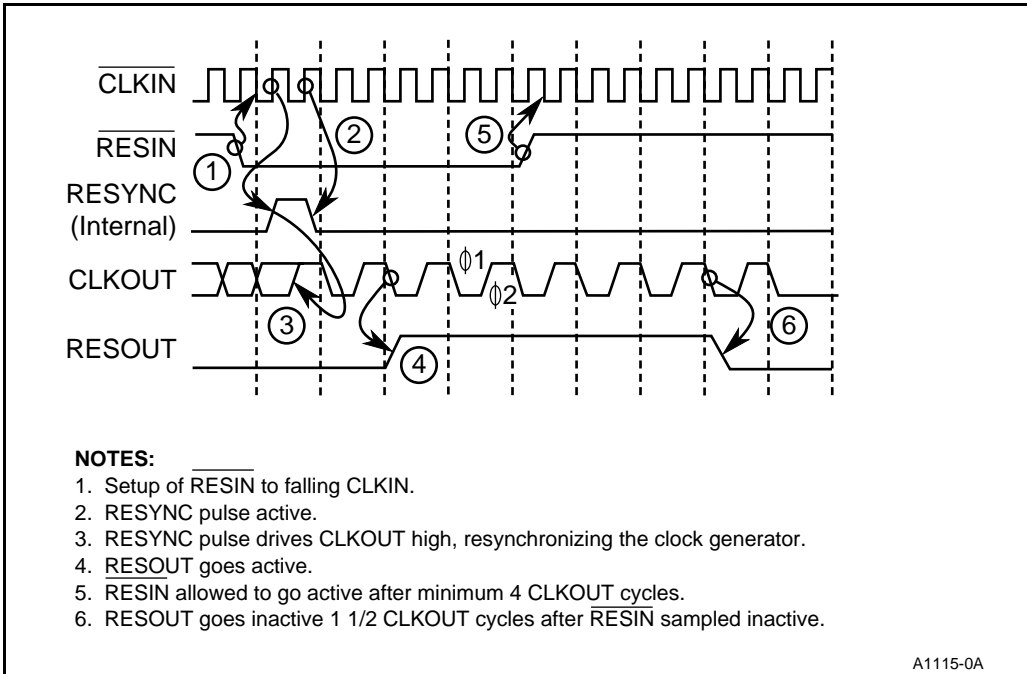

Figure 5-8. Clock Synchronization at Reset

5.2 POWER MANAGEMENT

Many VLSI devices available today use dynamic circuitry. A dynamic circuit uses a capacitor (usually parasitic gate or diffusion capacitance) to store information. The stored charge decays over time due to leakage currents in the silicon. If the device does not use the stored information before it decays, the state of the entire device may be lost. Circuits must periodically refresh dynamic RAMs, for example, to ensure data retention. Any microprocessor that has a minimum clock frequency has dynamic logic. On a dynamic microprocessor, if you stop or slow the clock, the dynamic nodes within it begin discharging. With a long enough delay, the processor is likely to lose its present state, needing a reset to resume normal operation.

An 80C186 Modular Core microprocessor is fully **static**. The CPU stores its current state in flip-flops, not capacitive nodes. The clock signal to both the CPU core and the peripherals can stop without losing any internal information, provided the design maintains power. When the clock restarts, the device will execute from its previous state. When the processor is inactive for significant periods, special power management hardware takes advantage of static operation to achieve major power savings.

There are three power management modes: Idle, Powerdown and Power-Save. Power-Save mode is a clock generation function, while Idle and Powerdown modes are clock distribution functions. For this discussion, Active mode is the condition of no programmed power management. Active mode operation feeds the clock signal to the CPU core and all the integrated peripherals and power consumption reaches its maximum for the application. The processor defaults to Active mode at reset.

5.2.1 Idle Mode

During Idle mode operation, the clock signal is routed only to the integrated peripheral devices. CLKOUT continues toggling. The clocks to the CPU core (Execution and Bus Interface Units) freeze in a logic low state. Idle mode reduces current consumption by about a third, depending on the activity in the peripheral units.

5.2.1.1 Entering Idle Mode

Setting the appropriate bit in the Power Control Register (Figure 5-9) prepares for Idle mode. The processor enters Idle mode when it executes the HLT (halt) instruction. If the program arms both Idle mode and Powerdown mode by mistake, the device halts but remains in Active mode. See Chapter 3, “Bus Interface Unit,” for detailed information on HALT bus cycles. Figure 5-10 shows some internal and external waveforms during entry into Idle mode.

Register Name: Power Control Register
Register Mnemonic: PWRCON
Register Function: Arms power management functions.

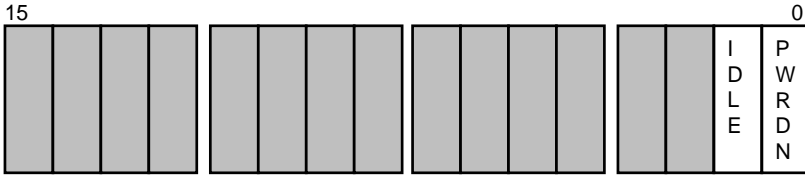

A1129-0A

Bit Mnemonic	Bit Name	Reset State	Function
IDLE	Idle Mode	0	Setting the IDLE bit forces the CPU to enter the Idle mode when the HLT instruction is executed. The PWRDN bit must be cleared when setting the IDLE bit, otherwise Idle mode is not armed.
PWRDN	Powerdown Mode	0	Setting the PWRDN bit forces the CPU to enter the Powerdown mode when the next HLT instruction is executed. The IDLE bit must be cleared when setting the PWRDN bit, otherwise Powerdown mode is not armed.

NOTE: Reserved register bits are shown with gray shading. Reserved bits must be written to a logic zero to ensure compatibility with future Intel products.

Figure 5-9. Power Control Register

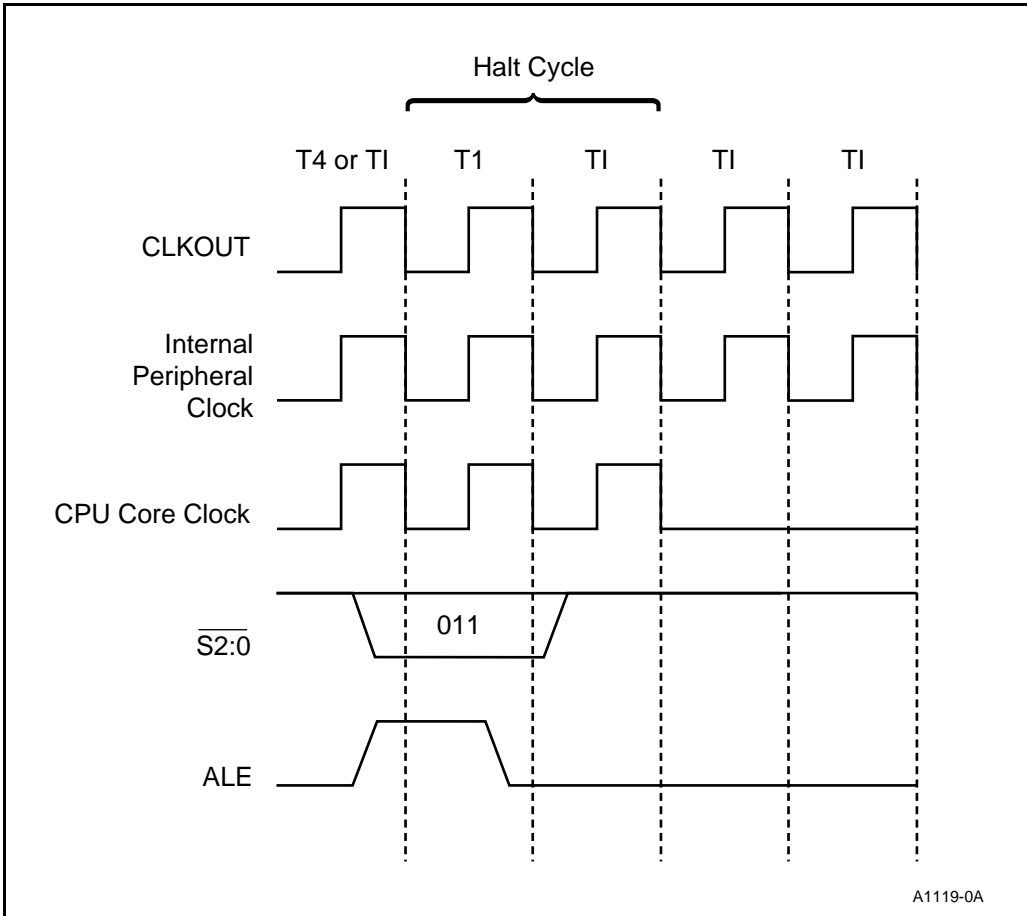

Figure 5-10. Entering Idle Mode

5.2.1.2 Bus Operation During Idle Mode

DMA requests, refresh requests and HOLD requests temporarily turn on the core clocks. If the processor needs to run a DMA cycle during Idle mode, the internal core clock begins to toggle on the falling CLKOUT edge three clocks after the processor samples the DMA request pin. After one idle T-state, the processor runs the DMA cycle. The BIU uses the ready, wait state generation and chip-select circuitry as necessary for DMA cycles during Idle mode. There is one idle T-state after T4 before the internal core clock shuts off again.

If the processor needs to run a refresh cycle during Idle mode, the internal core clock begins to toggle on the falling CLKOUT edge immediately after the down-counter reaches zero. After one idle T-state, the processor runs the refresh cycle. As with all other bus cycles, the BIU uses the ready, wait state generation and chip-select circuitry as necessary for refresh cycles during Idle mode. There is one idle T-state after T4 before the internal core clock shuts off again.

A HOLD request from an external bus master turns on the core clock as long as HOLD is active (see Figure 5-11). The core clock restarts one CLKOUT cycle after the bus processor samples HOLD high. The microprocessor asserts HLDA one cycle after the core clock starts. The core clock turns off and the processor deasserts HLDA one cycle after the external bus master deasserts HOLD.

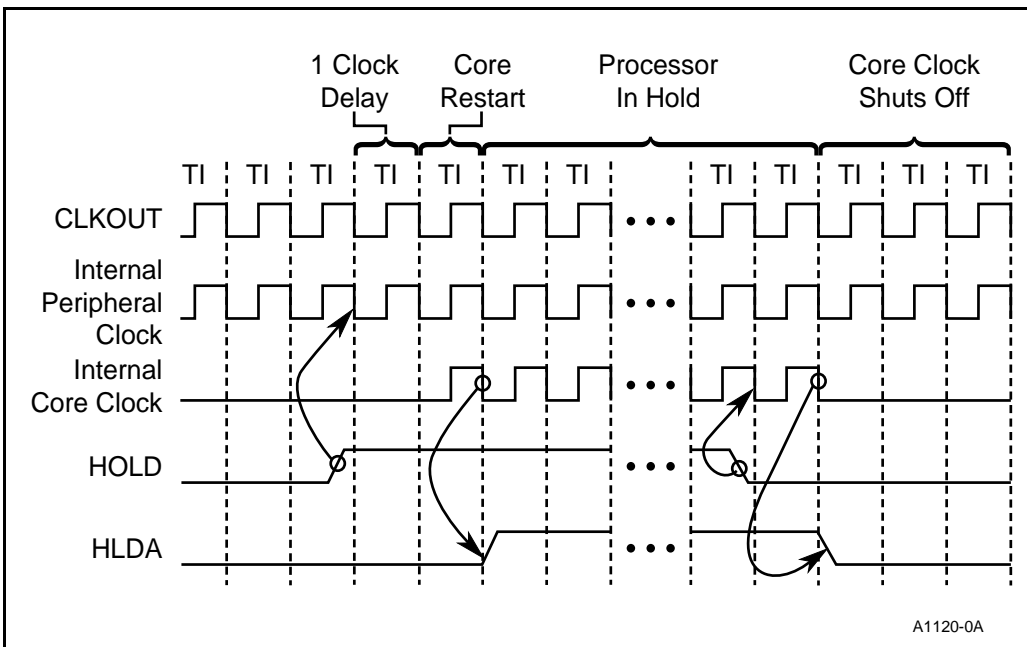

Figure 5-11. HOLD/HLDA During Idle Mode

As in Active mode, refresh requests will force the BIU to drop HLDA during bus hold. (For more information on refresh cycles during hold, see “Refresh Operation During a Bus HOLD” on page 3-43 and “Refresh Operation and Bus HOLD” on page 7-12.) Refresh requests will also correctly break into sequences of back-to-back DMA cycles.

5.2.1.3 Leaving Idle Mode

Any unmasked interrupt or non-maskable interrupt (NMI) will return the processor to Active mode. Reset also returns the processor to Active mode, but the device loses its prior state.

Any **unmasked** interrupt received by the core will return the processor to Active mode. Interrupt requests pass through the Interrupt Control Unit with an interrupt resolution time for mask and priority level checking. Then, after 1½ clocks, the core clock begins toggling. It takes an additional 6 CLKOUT cycles for the core to begin the interrupt vectoring sequence.

After execution of the IRET (interrupt return) instruction in the interrupt service routine, the CS:IP will point to the instruction following the HALT. Interrupt execution does not modify the Power Control Register. Unless the programmer intentionally reprograms the register after exiting Idle mode, the processor will re-enter Idle mode at the next HLT instruction.

Like an unmasked interrupt, an NMI will return the core to Active mode from Idle mode. It takes two CLKOUT cycles to restart the core clock after an NMI occurs. The NMI signal does not need the mask and priority checks that a maskable interrupt does. This results in a considerable difference in clock restart time between an NMI and an unmasked interrupt. The core begins the interrupt response six cycles after the core clock restarts when it fetches the NMI vector from location 00008H. NMI does not clear the IDLE bit in the Power Control Register.

Resetting the microprocessor will return the device to Active mode. Unlike interrupts, a reset clears the Power Control Register. Execution begins as it would following a warm reset (see “Reset and Clock Synchronization” on page 5-6).

5.2.1.4 Example Idle Mode Initialization Code

Example 5-1 illustrates programming the Power Control Register and entering Idle mode upon HLT. The interrupts from the serial port and timers are not masked. Assume that the serial port connects to a keyboard controller. At every keystroke, the keyboard sends a data byte, and the processor wakes up to service the interrupt. After acting on the keystroke, the core will go back into Idle mode. The example excludes the actual keystroke processing.

```

$mod186
name                example_80C186_power_management_code

;FUNCTION:          This function reduces CPU power consumption.
; SYNTAX:           extern void far power_mgt(int mode);
; INPUTS:           mode - 00 -> Active Mode
;                   01 -> Powerdown Mode
;                   02 -> Idle Mode
;                   03 -> Active Mode
;
; OUTPUTS:         None
; NOTE:            Parameters are passed on the stack as required
;                 by high-level languages

PWRCON equ xxxxxH                                ;substitute PWRCON register
                                                ;offset

lib_80C186        segment public 'code'
                  assume cs:lib_80C186
                  public _power_mgt
                  proc far

                  push bp                        ;save caller's bp
                  mov  bp, sp                    ;get current top of stack
                  push ax                        ;save registers that will
                  push dx                        ;be modified

                  _mode equ word ptr[bp+6]      ;get parameter off the
                                                ;stack
                  mov  dx, PWRCON                ;select Power Control Reg
                  mov  ax, _mode                ;get mode
                  and  ax, 3                     ;mask off unwanted bits
                  out  dx, ax
                  hlt                             ;enter mode
                  pop  dx                        ;restore saved registers
                  pop  ax
                  pop  bp                        ;restore caller's bp
                  ret

                  _power_mgt endp
lib_80C186        ends
                  end

```

Example 5-1. Initializing the Power Management Unit for Idle or Powerdown Mode

5.2.2 Powerdown Mode

Powerdown mode freezes the clock to the entire device (core and peripherals) and disables the crystal oscillator. All internal devices (registers, state machines, etc.) maintain their states as long as V_{CC} is applied. The BIU will not honor DMA, DRAM refresh and HOLD requests in Powerdown mode because the clocks for those functions are off. CLKOUT freezes in a logic high state. Current consumption in Powerdown mode consists of just transistor leakage (typically less than 100 microamps).

5.2.2.1 Entering Powerdown Mode

Powerdown mode is entered by executing the HLT instruction after setting the PWRDN bit in the Power Control Register (see Figure 5-9 on page 5-12). The HALT cycle turns off both the core and peripheral clocks and disables the crystal oscillator. See Chapter 3, “Bus Interface Unit,” for detailed information on HALT bus cycles. Figure 5-12 shows the internal and external waveforms during entry into Powerdown mode.

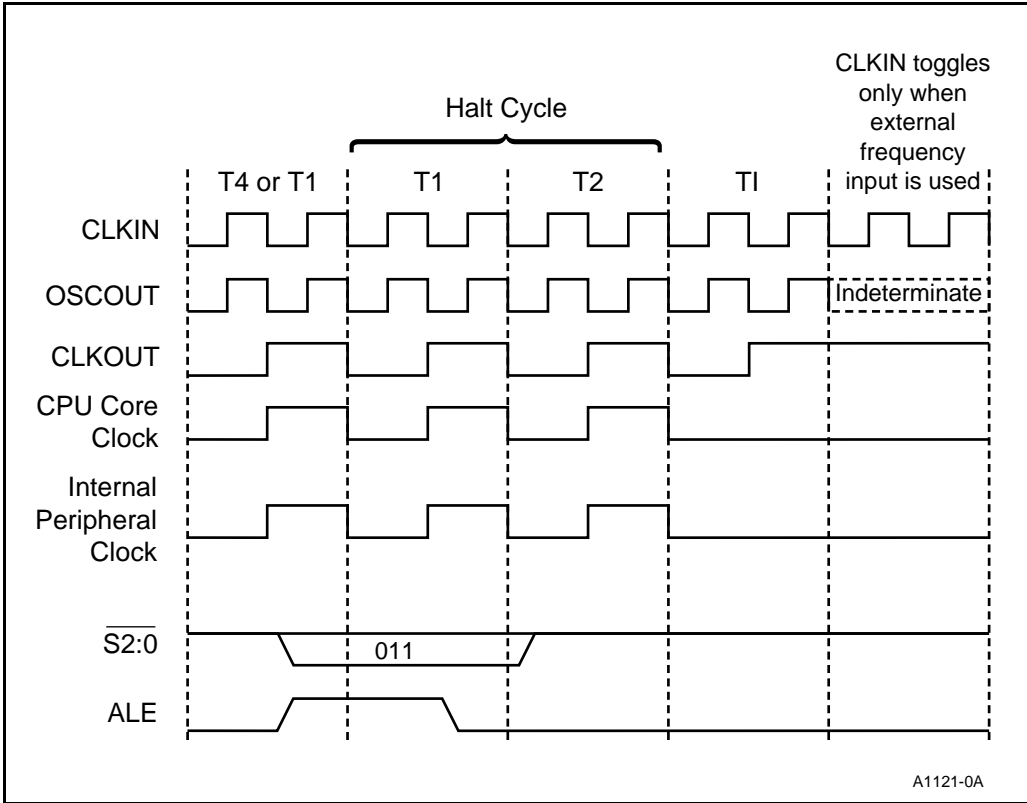

Figure 5-12. Entering Powerdown Mode

During the T2 phase of the HLT instruction, the core generates a signal called Enter_Powerdown. Enter_Powerdown immediately disables the internal CPU core and peripheral clocks. The processor disables the oscillator inverter during the next CLKOUT cycle. If the design uses a crystal oscillator, the oscillator stops immediately. When CLKIN originates from an external frequency input (EFI), Powerdown isolates the signal on the CLKIN pin from the internal circuitry. Therefore, the circuit may drive CLKIN during Powerdown mode, although it will not clock the device.

5.2.2.2 Leaving Powerdown Mode

An NMI or reset returns the processor to Active mode. If the device leaves Powerdown mode by an NMI, a delay must follow the interrupt request to allow the crystal oscillator to stabilize before gating it to the internal phase clocks. An external timing pin sets this delay as described below. Leaving Powerdown by an NMI does not clear the PWRDN bit in the Power Control Register. A reset also takes the processor out of Powerdown mode. Since the oscillator is off, the user should follow the oscillator cold start guidelines (see “Reset and Clock Synchronization” on page 5-6).

The Powerdown timer circuit (Figure 5-13) has a PDTMR pin. Connecting this pin to an external capacitor gives the user control over the gating of the crystal oscillator to the internal clocks. The strong P-channel device is always on except during exit from Powerdown mode. This pullup keeps the powerdown capacitor C_{PD} charged up to V_{CC} . C_{PD} discharges slowly. At the same time, the circuit turns on the feedback inverter on the crystal oscillator and oscillation starts.

The Schmitt trigger connected to the PDTMR pin asserts the internal OSC_OK signal when the voltage at the pin drops below its switching threshold. The OSC_OK signal gates the crystal oscillator output to the internal clock circuitry. One CLKOUT cycle runs before the internal clocks turn back on. It takes two additional CLKOUT cycles for an NMI request to reach the CPU and another six clocks for the vector to be fetched.

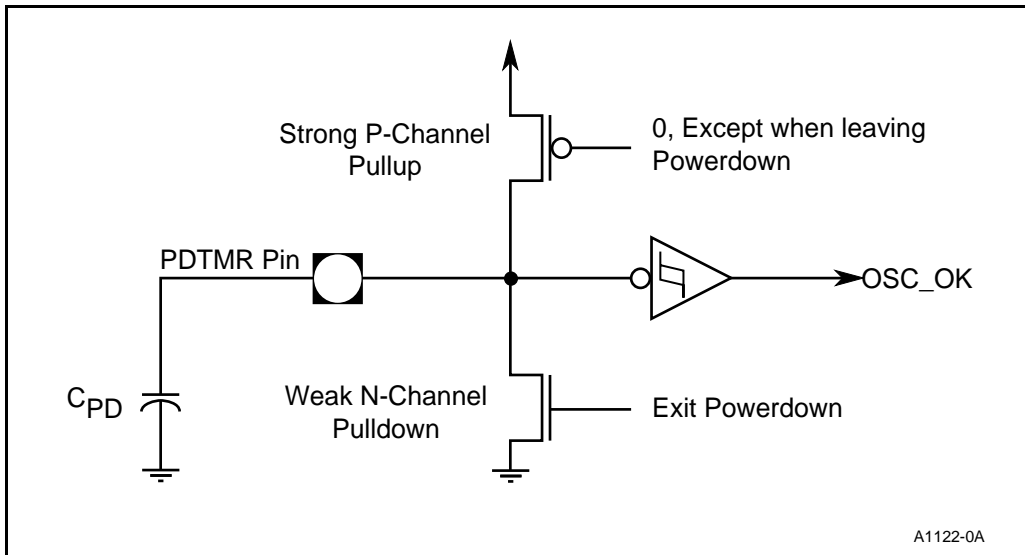

Figure 5-13. Powerdown Timer Circuit

The first step in determining the proper C_{PD} value is startup time characterization for the crystal oscillator circuit. This step can be done with a storage oscilloscope if you compensate for scope probe loading effects. Characterize startup over the full range of operating voltages and temperatures. The oscillator starts up on the order of a couple of milliseconds. After determining the oscillator startup time, refer to “PDTMR Pin Delay Calculation” in the data sheet. Multiply the startup time (in seconds) by the given constant to get the C_{PD} value. Typical values are less than $1\mu\text{F}$.

If the design uses an external oscillator instead of a crystal, the external oscillator continues running during Powerdown mode. Leave the PDTMR pin unconnected and the processor can exit Powerdown mode immediately.

5.2.3 Power-Save Mode

In addition to Idle and Powerdown modes, Power-Save mode provides another means for reducing operating current. Power-Save mode enables a programmable clock divider in the clock generation circuit. This divider operates in addition to the divide-by-two counter (see Figure 5-1 on page 5-1)

NOTE

Power-Save mode can be used to stretch bus cycles as an alternative to wait states.

Possible clock divisor settings are 1 (undivided), 4, 8 and 16. The divided frequency feeds the core, the integrated peripherals and CLKOUT. The processor operates at the divided clock rate exactly as if the crystal or external oscillator frequency were lower by the same amount. Since the processor is static, a lower limit clock frequency does not apply.

The advantage of Power-Save mode over Idle and Powerdown modes is that operation of both the core and the integrated peripherals can continue. However, it may be necessary to reprogram integrated peripherals such as the Timer Counter Unit and the Refresh Control Unit to compensate for the overall reduced clock rate.

5.2.3.1 Entering Power-Save Mode

The Power-Save Register (Figure 5-14) controls Power-Save mode operation. The lower two bits select the divisor. When program execution sets the PSEN bit, the processor enters Power-Save mode. The internal clock frequency changes at the falling edge of T3 of the write to the Power-Save Register. CLKOUT changes simultaneously and does not glitch. Figure 5-15 illustrates the change at CLKOUT.

Register Name: Power Save Register
Register Mnemonic: PWRSAV
Register Function: Enables and sets clock division factor.



A1130-0A

Bit Mnemonic	Bit Name	Reset State	Function
PSEN	Power Save Enable	0H	Setting this bit enables Power Save mode and divides the internal operating clock by the value defined by F1:0. Clearing this bit disables Power-Save mode and forces the CPU to operate at full speed. PSEN is automatically cleared whenever an interrupt occurs.
F1:0	Clock Division Factor	0H	These bits control the clock division factor used when Power Save mode is enabled. The allowable values are listed below: F1 F0 Divisor 0 0 By 1 (undivided) 0 1 By 4 1 0 By 8 1 1 By 16

NOTE: Reserved register bits are shown with gray shading. Reserved bits must be written to a logic zero to ensure compatibility with future Intel products.

Figure 5-14. Power-Save Register

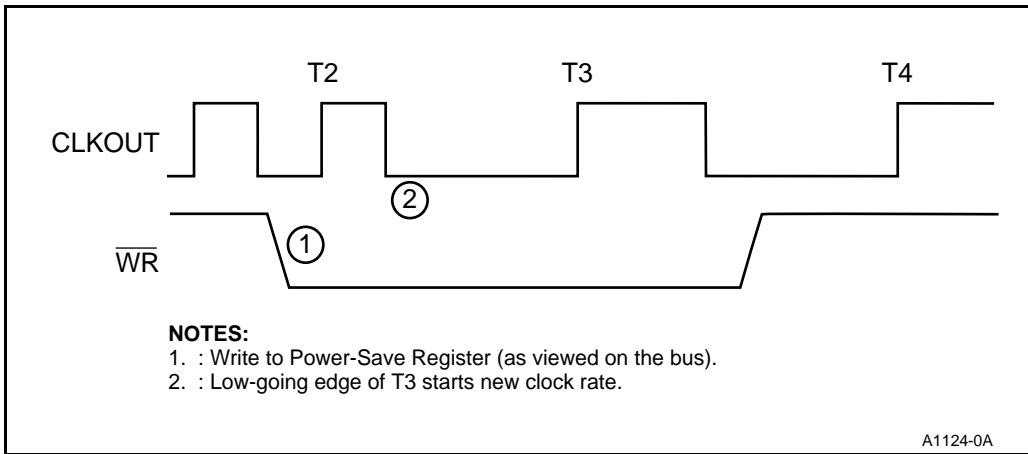

Figure 5-15. Power-Save Clock Transition

5.2.3.2 Leaving Power-Save Mode

Power-Save mode continues until one of three events occurs: execution clears the PSEN bit in the Power-Save Register, an unmasked interrupt occurs or an NMI occurs.

When the PSEN bit clears, the clock returns to its undivided frequency (standard divide-by-two) at the falling T3 edge of the write to the Power-Save Register. The same result happens from re-programming the clock divisor to a new value. The Power-Save Register can be read or written at any time.

Unmasked interrupts include those from the Interrupt Control Unit, but not software interrupts. If an NMI occurs, or an unmasked interrupt request has sufficient priority to pass to the core, Power-Save mode will end. The PSEN bit clears and the clock resumes full-speed operation at the falling edge of a bus cycle T3 state. However, the exact bus cycle of the transition is undefined. The Return from Interrupt instruction (IRET) does not automatically set the PSEN bit again. If you still want Power-Save mode operation, you can set the PSEN bit as part of the interrupt service routine.

5.2.3.3 Example Power-Save Initialization Code

Example 5-2 illustrates programming the Power-Save Unit for a typical system. The program also includes code to change the DRAM refresh rate to compensate for the reduced clock rate.

```

$mod186
name                example_PSU_code

;FUNCTION:          This function reduces CPU power consumption
;                  by dividing the CPU operating frequency by a
;                  divisor.
; SYNTAX:          extern void far power_save(int divisor);
; INPUTS:          divisor - This variable represents F0, F1 and F2
;                  of PWRSAV.
; OUTPUTS:        None
; NOTE:           Parameters are passed on the stack as required
;                  by high-level languages

PWRSAV               equ    xxxxH                ;substitute register offset
RFTIME               equ    xxxxH                ;Power-Save Register
;Refresh Interval Count
;Register
RFCON                equ    xxxxH                ;Refresh Control Register
PSEN                 equ    8000H                ;Power-Save enable bit

data                 segment public 'data'
FreqTable            dw 1, 4, 8, 16, 32, 64, 0, 0
data                 ends

lib_80C186           segment public 'code'
                    assume cs:lib_80C186, ds:data

                    public _power_save
_power_save          proc far

                    push  bp                    ;save caller's bp
                    mov   bp, sp                ;get current top of stack
                    push  ax                    ;save registers that will
                    push  dx                    ;be modified

_divisor             equ    word ptr[bp+6]        ;get parameter off the
;stack

                    mov   dx, RFTIME            ;get current DRAM refresh
                    in   ax, dx                 ;rate
                    and   ax, 01ffh            ;mask off unwanted bits

                    div   FreqTable[_divisor]    ;divide refresh rate
;by _divisor
                    out  dx, ax                ;set new refresh rate
                    mov  dx, PWRSAV            ;select Power-Save Register
                    mov  ax, _divisor          ;get divisor
                    and  ax, 7                  ;mask off unwanted bits
                    or   ax, PSEN              ;set enable bit
                    out  dx, ax                ;divide frequency
                    pop  dx                    ;restore saved registers
                    pop  bx
                    pop  ax
                    pop  bp                    ;restore caller's bp
                    ret

_power_save          endp

lib_80C186           ends
end

```

Example 5-2. Initializing the Power Management Unit for Power-Save Mode

5.2.4 Implementing a Power Management Scheme

Table 5-2 summarizes the power management options available to the user. With three ways available to reduce power consumption, here are some guidelines:

- Powerdown mode reduces power consumption by several orders of magnitude. If the application goes into and out of Powerdown frequently, the power reduction can probably offset the relatively long intervals spent leaving Powerdown mode.
- If background CPU tasks are usually necessary and the overhead of reprogramming peripherals is not severe, Power-Save mode can “tune” the clock rate to the best value. Remember that current varies linearly with respect to frequency.
- Idle mode fits DMA-intensive and interrupt-intensive (as opposed to CPU-intensive) applications perfectly.

The processor can operate in Power-Save mode and Idle mode concurrently. With Idle mode alone, rated power consumption typically drops a third or more. Power-Save mode multiplies that reduction further according to the selected clock divisor.

Overall power consumption has two parts: switching power dissipated by driving loads such as the address/data bus, and device power dissipated internally by the microprocessor whether or not it is connected to external devices. A power management scheme should consider loading as well as the raw specifications in the processor's data sheet.

Table 5-2. Summary of Power Management Modes

Mode	Relative Power	Typical Power	User Overhead	Chief Advantage
Active	Full	250 mW at 16 MHz	—	Full-speed operation
Idle	Low	175 mW at 16 MHz	Low	Peripherals are unaffected
Power-Save	Adjustable	125 mW at 16/2 MHz	Moderate to High	Code execution continues
Powerdown	Lowest	250 μ W	Low to Moderate	Long battery life

NOTE

If an NMI or external maskable interrupt service routine is used to enter a power management mode, the interrupt request signal should be deasserted before entering the power management mode.



6

Chip-Select Unit



CHAPTER 6

CHIP-SELECT UNIT

Every system requires some form of component-selection mechanism to enable the CPU to access a specific memory or peripheral device. The signal that selects the memory or peripheral device is referred to as a chip-select. Besides selecting a specific device, each chip-select can be used to control the number of wait states inserted into the bus cycle. Devices that are too slow to keep up with the maximum bus bandwidth can use wait states to slow the bus down.

6.1 COMMON METHODS FOR GENERATING CHIP-SELECTS

One method of generating chip-selects uses latched address signals directly. An example interface is shown in Figure 6-1(A). In the example, an inverted A16 is connected to an SRAM device with an active-low chip-select. Any bus cycle with an address between 10000H and 1FFFFH (A16 = 1) enables the SRAM device. Also note that any bus cycle with an address starting at 30000H, 50000H, 70000H and so on also selects the SRAM device.

Decoding more address bits solves the problem of a chip-select being active over multiple address ranges. In Figure 6-1(B), a one-of-eight decoder is connected to the uppermost address bits. Each decoded output is active for one-eighth of the 1 Mbyte address space. However, each chip-select has a fixed starting address and range. Future system memory changes could require circuit changes to accommodate the additional memory.

6.2 CHIP-SELECT UNIT FEATURES AND BENEFITS

The Chip-Select Unit overcomes limitations of the designs shown in Figure 6-1 and has the following features:

- Ten chip-select outputs
- Programmable start and stop addresses
- Memory or I/O bus cycle decoder
- Programmable wait-state generator
- Provision to disable a chip-select
- Provision to override bus ready

Figure 6-2 illustrates the logic blocks that generate a chip-select. Each chip-select has a duplicate set of logic.

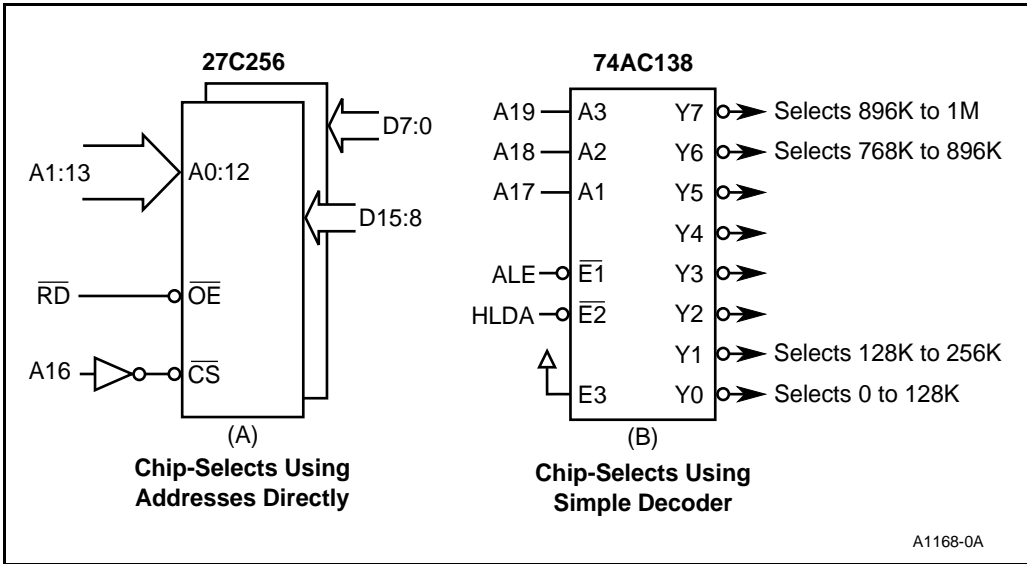

Figure 6-1. Common Chip-Select Generation Methods

6.3 CHIP-SELECT UNIT FUNCTIONAL OVERVIEW

The Chip-Select Unit (CSU) decodes bus cycle address and status information and enables the appropriate chip-select. Figure 6-3 illustrates the timing of a chip-select during a bus cycle. Note that the chip-select goes active in the same bus state as address goes active, eliminating any delay through address latches and decoder circuits. The Chip-Select Unit activates a chip-select for bus cycles initiated by the CPU, DMA Control Unit or Refresh Control Unit.

Six of the chip-selects map only into memory address space, while the remaining seven can map into either memory or I/O address space. The chip-selects typically associate with memory and peripheral devices as follows:

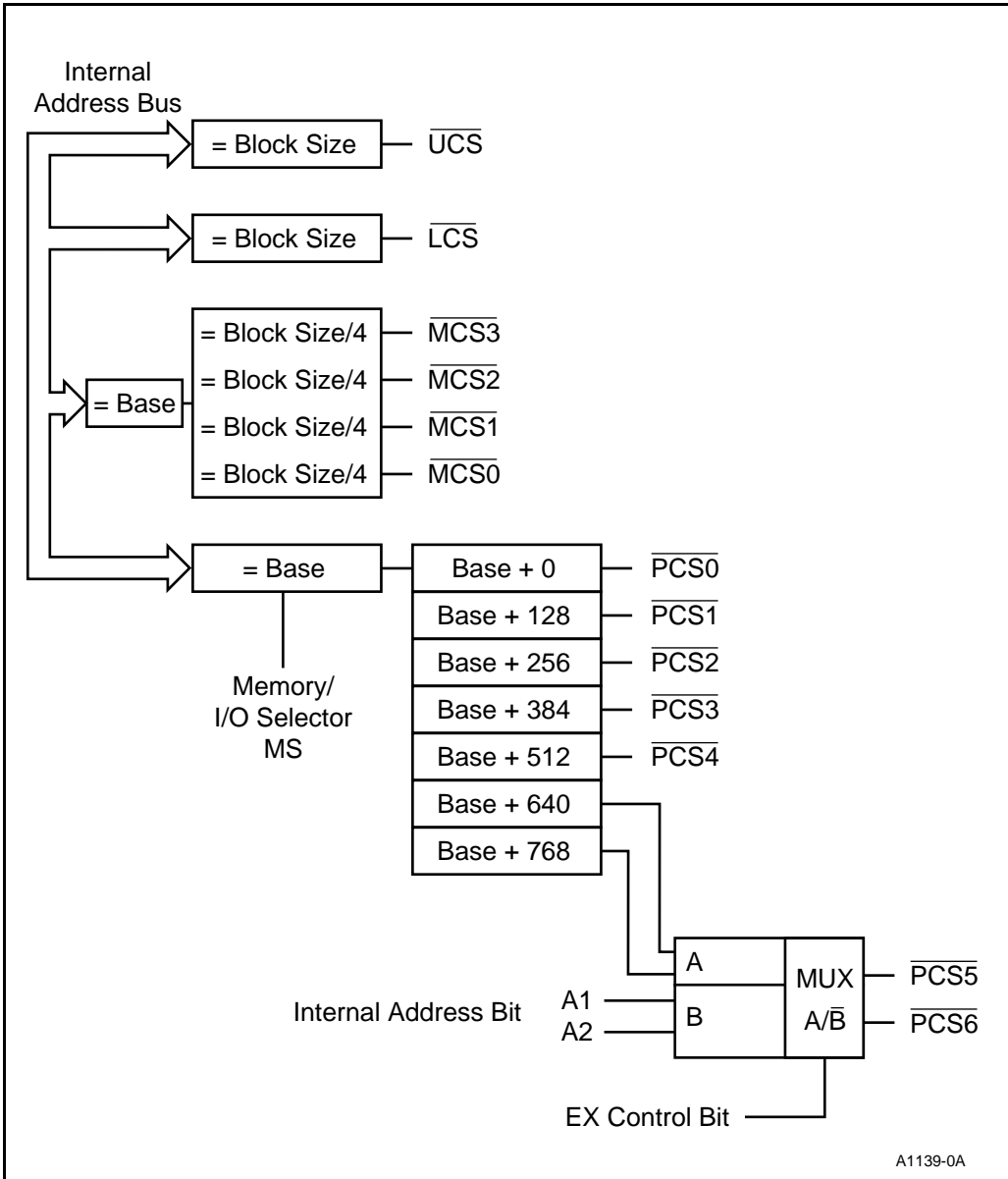

Figure 6-2. Chip-Select Block Diagram

- UCS Mapped only to the upper memory address space; selects the BOOT memory device (EPROM or Flash memory types).
- LCS Mapped only to the lower memory address space; selects a static memory (SRAM) device that stores the interrupt vector table, local stack, local data, and scratch pad data.
- MCS3:0 Mapped only to memory address space; selects additional SRAM memory, DRAM memory, or the system bus.
- PCS6:0 Mapped to memory or I/O address space; selects peripheral devices or generates a DMA acknowledge strobe. Note that each PCS_x is not individually configurable for I/O space or memory space.

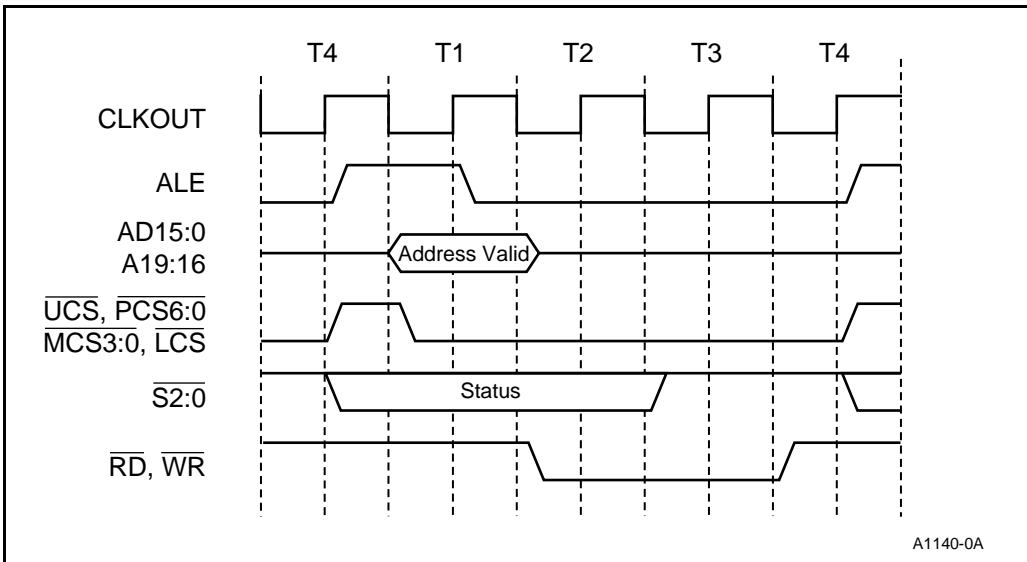

Figure 6-3. Chip-Select Relative Timings

The UCS chip-select always ends at address location 0FFFFH; its block size (and thus its starting address) is programmed in the UMCS register (Figure 6-5 on page 6-7). The LCS chip-select always starts at address location 0H; its block size (and thus its ending address) is programmed in the LMCS Control register (Figure 6-6 on page 6-8). The block size can range from 1 Kbyte to 256 Kbytes for both.

The MCS3:0 chip-selects access a contiguous block of memory address space. The block size can range from 8 Kbytes to 512 Kbytes; it is programmed in the MMCS register (Figure 6-7 on page 6-9). Each chip-select goes active for one-fourth of the block. The start address is programmed in the MPCS register (Figure 6-9 on page 6-11); it must be an integer multiple of the block size. Because of the start address limitation, the MCS3:0 chip-selects cannot cover the entire memory address space between the LCS and UCS chip-selects.

By combining \overline{LCS} , \overline{UCS} and $\overline{MCS3:0}$, you can cover up to 786 Kbytes of memory address space. Methods such as those shown in Figure 6-1 on page 6-2 can be used to decode the remaining 256 Kbytes.

The $\overline{PCS6:0}$ chip-selects access a contiguous, 896-byte block of memory or I/O address space. Each chip-select goes active for one-seventh of the block (128 bytes). The start address is programmed in the PACS register (Figure 6-8 on page 6-10); it can begin on any 1 Kbyte boundary.

A chip-select goes active when it meets all of the following criteria:

1. The chip-select is enabled.
2. The bus cycle status matches the default or programmed type (memory or I/O).
3. The bus cycle address is within the default or programmed block size.
4. The bus cycle is **not** accessing the Peripheral Control Block.

A memory address applies to memory read, memory write and instruction prefetch bus cycles. An I/O address applies to I/O read and I/O write bus cycles. Interrupt acknowledge and HALT bus cycles never activate a chip-select, regardless of the address generated.

After power-on or system reset, only the \overline{UCS} chip-select is initialized and active (see Figure 6-4).

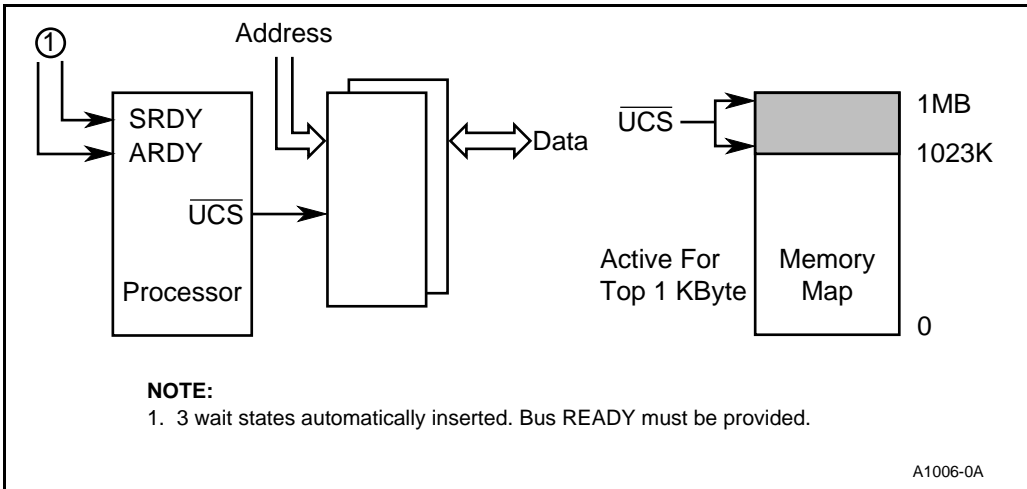

Figure 6-4. \overline{UCS} Reset Configuration

6.4 PROGRAMMING

Four registers determine the operating characteristics of the chip-selects. The Peripheral Control Block defines the location of the Chip-Select Unit registers. Table 6-1 lists the registers and their associated programming names.

Table 6-1. Chip-Select Unit Registers

Control Register Mnemonic	Alternate Register Mnemonic	Chip-Select Affected
UMCS	None	\overline{UCS}
LMCS	None	\overline{LCS}
MMCS	MPCS	$\overline{MCS3:0}$
PACS	MPCS	$\overline{PCS6:0}$

The control registers (Figures 6-5 through 6-7) define the base address and bus ready and wait state requirements for the corresponding chip-selects. The alternate control register (Figure 6-9) defines the block size for $\overline{MCS3:0}$. It also selects memory or I/O space for $\overline{PCS6:0}$, selects the function of the $\overline{PCS6:5}$ pins, and defines the bus ready and wait state requirements for $\overline{PCS6:4}$.

6.4.1 Initialization Sequence

Chip-selects do not have to be initialized in any specific order. However, the following guidelines help prevent a system failure.

1. Initialize local memory chip-selects
2. Initialize local peripheral chip-selects
3. Perform local diagnostics
4. Initialize off-board memory and peripheral chip-selects
5. Complete system diagnostics

An unmasked interrupt or NMI must not occur until the interrupt vector addresses have been written to memory. Failure to prevent an interrupt from occurring during initialization will cause a system failure. Use external logic to generate the chip-select if interrupts cannot be masked prior to initialization.

Register Name: \overline{UCS} Control Register
Register Mnemonic: UMCS
Register Function: Controls the operation of the \overline{UCS} chip-select.

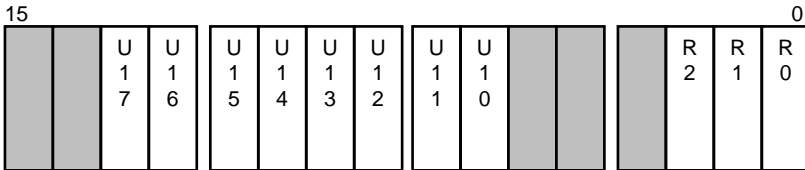

A1141-0A

Bit Mnemonic	Bit Name	Reset State	Function
U17:10	Start Address	0FFH	Defines the starting address for the chip-select. During memory bus cycles, U17:10 are compared with the A17:10 address bits. An \overline{UCS} chip-select if A19:18 are both one. Table 6-2 on page 6-12 lists the only valid programming combinations.
R2	Bus Ready Disable	0H	When R2 is clear, bus ready must be active to complete a bus cycle. When R2 is set, R1:0 control the number of bus wait states and bus ready is ignored.
R1:0	Wait State Value	3H	R1:0 define the minimum number of wait states inserted into the bus cycle.

NOTE: Reserved register bits are shown with gray shading. Reserved bits must be written to a logic zero to ensure compatibility with future Intel products. Programming U17:10 with values other than those shown in Table 6-2 on page 6-12 results in unreliable chip-select operation. Reading this register (before writing it) enables the chip-select; however, none of the programmable fields will be properly initialized.

Figure 6-5. UMCS Register Definition

Register Name: $\overline{\text{LCS}}$ Control Register
Register Mnemonic: LMCS
Register Function: Controls the operation of the $\overline{\text{LCS}}$ chip-select.

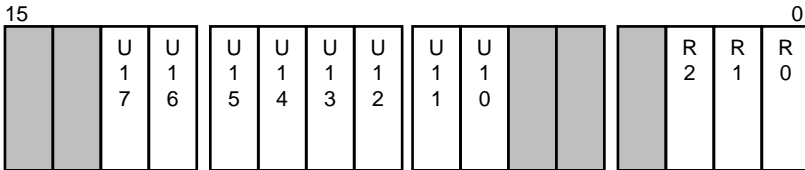

A1142-0A

Bit Mnemonic	Bit Name	Reset State	Function
U17:10	Ending Address	00H	Defines the ending address for the chip-select. During memory bus cycles, U17:10 are compared with the A17:10 address bits. A less than result enables the $\overline{\text{LCS}}$ chip-select if A19:18 are both zero. Table 6.3 on page 6-13 lists the only valid programming combinations.
R2	Bus Ready Disable	X	When R2 is clear, bus ready must be active to complete a bus cycle. When R2 is set, R1:0 control the number of bus wait states and bus ready is ignored.
R1:0	Wait State Value	3H	R1:0 define the minimum number of wait states inserted into the bus cycle.

NOTE: Reserved register bits are shown with gray shading. Reserved bits must be written to a logic zero to ensure compatibility with future Intel products. Programming U17:10 with values other than those shown in Table 6.3 on page 6-13 results in unreliable chip-select operation. Reading this register (before writing it) enables the chip-select; however, none of the programmable fields will be properly initialized.

Figure 6-6. LMCS Register Definition

Register Name: $\overline{\text{PCS}}$ Control Register
Register Mnemonic: PACS
Register Function: Controls the operation of the $\overline{\text{PCS}}$ chip-selects.

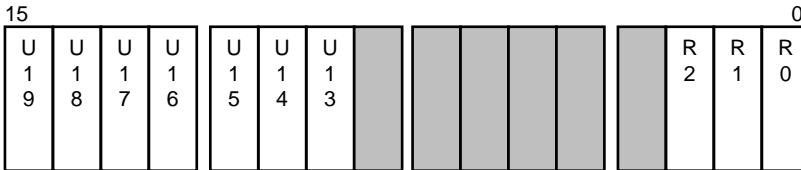

A1143-0B

Bit Mnemonic	Bit Name	Reset State	Function
U19:13	Start Address	XXH	Defines the starting address for the block of $\overline{\text{PCS}}$ chip-selects. During memory or I/O bus cycles, U19:13 are compared with the A19:13 address bits. An equal to or greater than result enables the $\overline{\text{PCS}}$ chip-select. U19:16 must be programmed to zero for proper I/O bus cycle operation.
R2	Bus Ready Disable	X	When R2 is clear, bus ready must be active to complete a bus cycle. When R2 is set, R1:0 control the number of bus wait states and bus ready is ignored.
R1:0	Wait State Value	3H	R1:0 define the minimum number of wait states inserted into the bus cycle.

NOTE: Reserved register bits are shown with gray shading. Reserved bits must be written to a logic zero to ensure compatibility with future Intel products. U19:16 must be programmed to zero for proper I/O bus cycle operation. Reading this register and the MPCS register (before writing them) enables the $\overline{\text{PCS}}$ chip-selects; however, none of the programmable fields will be properly initialized.

Figure 6-8. PACS Register Definition

Register Name: $\overline{\text{MCS}}$ and $\overline{\text{PCS}}$ Alternate Control Register
Register Mnemonic: MPCS
Register Function: Controls operation of the $\overline{\text{MCS}}$ and $\overline{\text{PCS}}$ chip-selects.

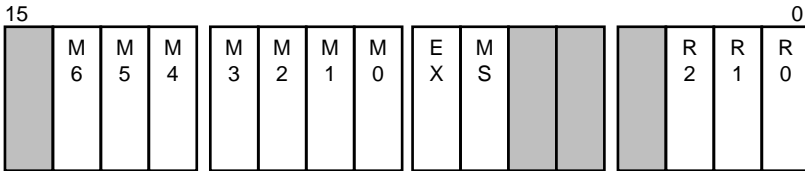

A1144-0A

Bit Mnemonic	Bit Name	Reset State	Function
M6:0	Block Size	XXH	Defines the block size for the MCS chip-selects. Table 6-5 on page 6-14 lists allowable values.
EX	Pin Selector	XH	Setting EX configures $\overline{\text{PCS6:5}}$ as chip-selects. Clearing EX configures the pins as latched address bits A2:A1.
MS	Bus Cycle Selector	XH	Clearing MS activates $\overline{\text{PCS6:0}}$ for I/O bus cycles. Setting MS activates $\overline{\text{PCS6:0}}$ for memory bus cycles.
R2	Bus Ready Disable for $\overline{\text{PCS6:4}}$	X	Applies only to $\overline{\text{PCS6:4}}$. When R2 is clear, bus ready must be active to complete a bus cycle. When R2 is set, R1:0 control the number of bus wait states and bus ready is ignored.
R1:0	Wait State Value for $\overline{\text{PCS6:4}}$	3H	Apply only to $\overline{\text{PCS6:4}}$. R1:0 define the minimum number of wait states inserted into the bus cycle.

NOTE: Reserved register bits are shown with gray shading. Reserved bits must be written to a logic zero to ensure compatibility with future Intel products. A starting address other than an integer multiple of the block size defined in this register causes unreliable chip-select operation. Reading this register and the MMCS or PACS register (before writing them) enables the associated chip-selects; however, none of the programmable fields will be properly initialized.

Figure 6-9. MPCS Register Definition

The UMCS and LMCS registers can be programmed in any sequence. To program the $\overline{\text{MCS}}$ and $\overline{\text{PCS}}$ chip-selects, follow this sequence:

1. Program the MPCS register
2. Program the MMCS register to enable the $\overline{\text{MCS}}$ chip-selects.
3. Program the PACS register to enable the $\overline{\text{PCS}}$ chip-selects.

6.4.2 Programming the Active Ranges

The active ranges of the chip-selects are determined by a combination of their starting or ending addresses and block sizes. This section describes how to control the active range of each chip-select.

6.4.2.1 $\overline{\text{UCS}}$ Active Range

The $\overline{\text{UCS}}$ starting address is 100000H (1 Mbyte) minus the block size; its ending address is fixed at 0FFFFFFH. Table 6-2 defines the acceptable values for the field (U17:10) in the UMCS register that determines the $\overline{\text{UCS}}$ block size and starting address.

Table 6-2. $\overline{\text{UCS}}$ Block Size and Starting Address

UMCS Field U17:10	Block Size (Kbytes)	Starting Address
00H	256	0C0000H
80H	128	0E0000H
C0H	64	0F0000H
E0H	32	0F8000H
F0H	16	0FC000H
F8H	8	0FE000H
FCH	4	0FF000H
FEH	2	0FF800H
FFH	1	0FFC00H

6.4.2.2 $\overline{\text{LCS}}$ Active Range

The $\overline{\text{LCS}}$ starting address is fixed at zero in memory address space; its ending address is the programmed block size minus one. Table 6.3 defines the acceptable values for the field (U17:10) in the LMCS register that determines the $\overline{\text{LCS}}$ block size and ending address.

Table 6.3 $\overline{\text{LCS}}$ Active Range

LMCS Field U17:10	Block Size (Kbytes)	Ending Address
00H	1	003FFH
01H	2	007FFH
03H	4	00FFFH
07H	8	01FFFH
0FH	16	03FFFH
1FH	32	07FFFH
3FH	64	0FFFFH
7FH	128	1FFFFH
FFH	256	3FFFFH

6.4.2.3 $\overline{\text{MCS}}$ Active Range

The starting and ending addresses of the individual $\overline{\text{MCS}}$ chip-selects are determined by the base address programmed in the MMCS register and the block size programmed in the MPCS register (see Table 6-4 and Figure 6-10). The base address must be an integer multiple of the block size. Table 6-5 lists the allowable block sizes and base address limitations.

Table 6-4. $\overline{\text{MCS}}$ Active Range

Chip-Select	Active Range	
	Start Address	Ending Address
$\overline{\text{MCS}}_0$	Base	Base + (1/4 block size - 1)
$\overline{\text{MCS}}_1$	Base + 1/4 block size	Base + (1/2 block size - 1)
$\overline{\text{MCS}}_2$	Base + 1/2 block size	Base + (3/4 block size - 1)
$\overline{\text{MCS}}_3$	Base + 3/4 block size	Base + (block size - 1)

Table 6-5. $\overline{\text{MCS}}$ Block Size and Start Address Restrictions

MPCS Block Size Bits							Block Size (Kbytes)	MMCS Start Address Restrictions
M6	M5	M4	M3	M2	M1	M0		
0	0	0	0	0	0	1	8	None
0	0	0	0	0	1	X	16	U13 must be zero.
0	0	0	0	1	X	X	32	U14:13 must be zero.
0	0	0	1	X	X	X	64	U15:13 must be zero.
0	0	1	X	X	X	X	128	U16:13 must be zero.
0	1	X	X	X	X	X	256	U17:13 must be zero.
1	X	X	X	X	X	X	512	U18:13 must be zero. NOTE: If U19 is one, will overlap $\overline{\text{UCS}}$.

X= don't care, but should be 0 for future compatibility.

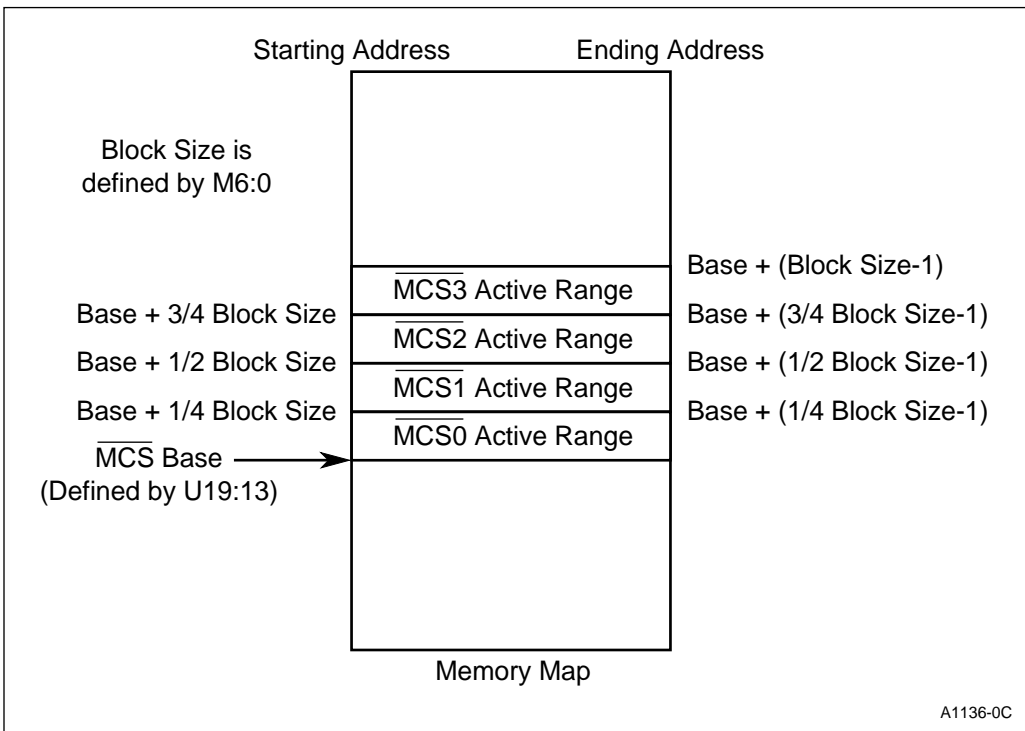

A1136-0C

Figure 6-10. $\overline{\text{MCS3:0}}$ Active Ranges

6.4.2.4 $\overline{\text{PCS}}$ Active Range

Each $\overline{\text{PCS}}$ chip-select starts at an offset above the base address programmed in the PACS register and is active for 128 bytes. The base address can start on any 1 Kbyte memory or I/O address location. Table 6-6 lists the active range for each $\overline{\text{PCS}}$ chip-select.

Table 6-6. $\overline{\text{PCS}}$ Active Range

Chip-Select	Active Range	
	Start Address	Ending Address
$\overline{\text{PCS0}}$	Base	Base + 127 (7FH)
$\overline{\text{PCS1}}$	Base + 128 (080H)	Base + 255 (0FFH)
$\overline{\text{PCS2}}$	Base + 256 (100H)	Base + 383 (17FH)
$\overline{\text{PCS3}}$	Base + 384 (180H)	Base + 511 (1FFH)
$\overline{\text{PCS4}}$	Base + 512 (200H)	Base + 639 (27FH)
$\overline{\text{PCS5}}$	Base + 640 (280H)	Base + 767 (2FFH)
$\overline{\text{PCS6}}$	Base + 768 (300H)	Base + 895 (37FH)

6.4.3 Bus Wait State and Ready Control

Normally, the bus ready input must be inactive at the appropriate time to insert wait states into the bus cycle. The Chip-Select Unit can ignore the state of the bus ready input to extend and complete the bus cycle automatically. Most memory and peripheral devices operate properly using three or fewer wait states. However, accessing such devices as a dual-port memory, an expansion bus interface, a system bus interface or remote peripheral devices can require more than three wait states to complete a bus cycle.

A three-bit field (R2:0) in the control registers defines the number of wait states and the ready requirements for the chip-selects. Figure 6-11 shows a simplified logic diagram of the wait state and ready control functions.

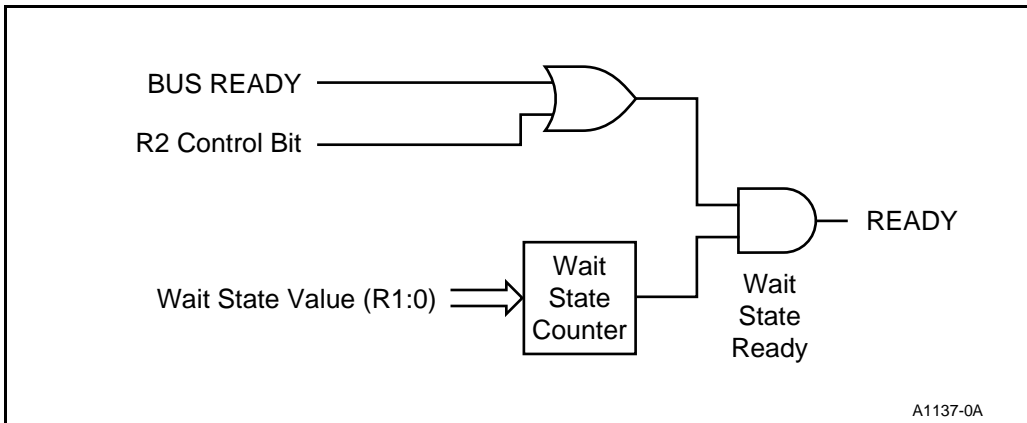

Figure 6-11. Wait State and Ready Control Functions

The R2 control bit determines whether the bus cycle completes normally (requires bus ready) or unconditionally (ignores bus ready). The R1:0 bits define the number of wait states to insert into the bus cycle. For devices requiring three or fewer wait states, you can set R2 (ignore bus ready) and program R1:0 with the number of required wait states. For devices that may require more than three wait states, you must clear R2 (require bus ready).

A bus cycle with wait states automatically inserted cannot be shortened. A bus cycle that ignores bus ready cannot be lengthened.

6.4.4 Overlapping Chip-Selects

The Chip-Select Unit activates all enabled chip-selects programmed to cover the same physical address space. This is true if any portion of the chip-selects' address ranges overlap (i.e., chip-selects' ranges do not need to overlap completely to all go active). There are various reasons for overlapping chip-selects. For example, a system might have a need for overlapping a portion of read-only memory with read/write memory or copying data to two devices simultaneously.

If overlapping chip-selects do not have identical wait state and bus ready programming, the Chip-Select Unit uses the following priority scheme:

1. If any \overline{MCS} chip-select is active, it uses the R2:0 bits in the MPCS register.
2. If the \overline{PCS} chip-selects overlap \overline{LCS} , it uses the R2:0 bits in the LMCS register.
3. If the \overline{PCS} chip-selects overlap \overline{UCS} , it uses the R2:0 bits in the UMCS register.

For example, assume $\overline{MCS3}$ overlaps \overline{UCS} . $\overline{MCS3}$ is programmed for two wait states and requires bus ready, while \overline{UCS} is programmed for no wait states and ignores bus ready. An access to the overlapped region has two wait states and requires bus ready (the values programmed in the R2:0 bits in the MPCS register).

Be cautious when overlapping chip-selects with different wait state or bus ready programming. The following two conditions require special attention to ensure proper system operation:

1. When all overlapping chip-selects ignore bus ready but have different wait states, verify that each chip-select still works properly using the highest wait state value. A system failure may result when too few or too many wait states occur in the bus cycle.
2. If one or more of the overlapping chip-selects requires bus ready, verify that all chip-selects that **ignore** bus ready still work properly using both the smallest wait state value and the longest possible bus cycle. A system failure may result when too few or too many wait states occur in the bus cycle.

6.4.5 Memory or I/O Bus Cycle Decoding

The \overline{UCS} , \overline{LCS} and \overline{MCS} chip-selects activate only for memory bus cycles. The \overline{PCS} chip-selects activate for either memory or I/O bus cycles, depending on the state of the MS bit in the MPCS register (Figure 6-9 on page 6-11). Memory bus cycles consist of memory read, memory write and instruction prefetch cycles. I/O bus cycles consist of I/O read and I/O write cycles.

Chip-selects go active for bus cycles initiated by the CPU, DMA Control Unit and Refresh Control Unit.

6.4.6 Programming Considerations

When programming the \overline{PCS} chip-selects active for I/O bus cycles, remember that eight bytes of I/O are reserved by Intel. These eight bytes (locations 00F8H through 00FFH) control the interface to an 80C187 math coprocessor. A chip-select can overlap this reserved space provided there is no intention of using the 80C187. However, to avoid possible future compatibility issues, Intel recommends that the \overline{PCS} chip-selects not start at I/O address location 0H.

Reading or writing the chip-select registers enables the corresponding chip-select. Reading a register before writing to it enables the chip-select without initializing the programmable fields, which causes indeterminate operation. For example, reading the LMCS register enables the \overline{LCS} chip-select, but it does not ensure that \overline{LCS} is programmed correctly. Once you enable a chip-select, you cannot disable it, but you can change its operation by writing to the appropriate register.

6.5 CHIP-SELECTS AND BUS HOLD

The Chip-Select Unit decodes only internally generated address and bus state information. An external bus master cannot make use of the Chip-Select Unit. During HLDA, all chip-selects remain inactive.

The circuit shown in Figure 6-12 allows an external bus master to access a device during bus HOLD.

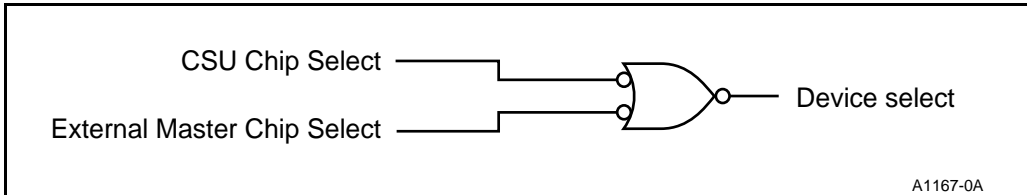

Figure 6-12. Using Chip-Selects During HOLD

6.6 EXAMPLES

The following sections provide examples of programming the Chip-Select Unit to meet the needs of a particular application. The examples do not go into hardware analysis or design issues.

6.6.1 Example 1: Typical System Configuration

Figure 6-13 illustrates a block diagram of a typical system design with a 128 Kbyte EPROM and a 32 Kbyte SRAM. The peripherals are mapped to I/O address space. Example 6.1 shows a program template for initializing the Chip-Select Unit.

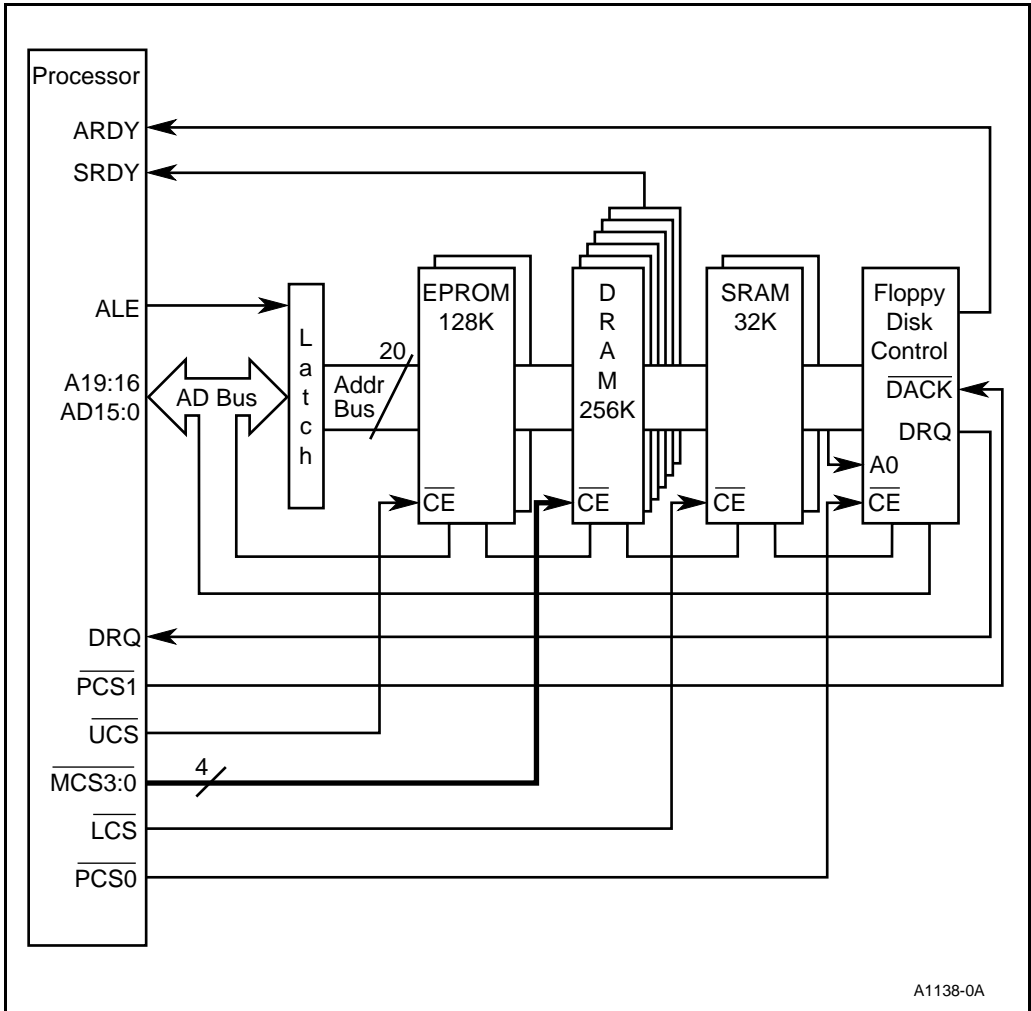

A1138-0A

Figure 6-13. Typical System

```

$          TITLE           (Chip-Select Unit Initialization)
$          MOD186XREF
$          NAME            CSU_EXAMPLE_1

; External reference from this module

$          include(PCBMAP.INC           ;File declares register
                                         ;locations and names.

; Module equates

; Configuration equates

          INTRDY EQU      0004H           ;Internal bus ready modifier
          EXTRDY EQU      0000H           ;External bus ready modifier
          IO      EQU      0080H           ;PCS Memory/IO select modifier
          ALLPCS EQU      0040H           ;PCS/Latched address modifier

;Below is a list of the default system memory and I/O environment. These
;defaults configure the Chip-Select Unit for proper system operation.

;EPROM memory is located from 0E0000 to 0FFFFFF (128 Kbytes).
;Wait states are calculated assuming 16MHz operation.
;UCS# controls the accesses to EPROM memory space.

          EPROM_SIZE EQU 128              ;Size in Kbytes
          EPROM_BASE EQU 1024 - EPROM_SIZE;Start address in Kbytes
          EPROM_WAIT EQU 1                ;Wait states

;The UMCS register values are calculated using the above system constraints
;and the equations below.

          UMCS_VAL EQU (EPROM_BASE SHL 6)OR (0C038H) OR
&          (EPROM_RDY)      OR (EPROM_WAIT)

;SRAM memory starts at 0H and continues to 7FFFH (32 Kbytes).
;Wait states are calculated assuming 16MHz operation.
;LCS# controls the accesses to SRAM memory space.

          SRAM_SIZE EQU 32                ;Size in Kbytes
          SRAM_BASE EQU 0                 ;Start address in Kbytes
          SRAM_WAIT EQU 0                 ;Wait states
          SRAM_RDY EQU INTRDY             ;Ignore bus ready

;The LMCS register value is calculated using the above system constraints
;and the equations below

          LMCS_VAL EQU ((SRAM_SIZE - 1)SHL6) OR (0038H) OR
&          (SRAM_RDY)      OR (SRAM_WAIT)

;A DRAM interface is selected by the MCS3:0 chip-selects. The BASE value
;defines the starting address of the DRAM window. The SIZE value (along with
;the BASE ;value) defines the ending address. Zero wait state performance
;is assumed. The Refresh Control Unit uses DRAM_BASE to properly configure
;refresh operation.

```

Example 6-1. Initializing the Chip-Select Unit

```

DRAM_BASE EQU 256 ;window start address in Kbytes
DRAM_SIZE EQU 256 ;window size in Kbytes
DRAM_WAIT EQU 0 ;wait states
DRAM_RDY EQU INTRDY ;ignore bus ready

;The MPCS register is used to program both the MCS and PCS chip-selects.
;Below are the equates for the I/O peripherals (also used to program the PACS
;register.

IO_WAIT EQU 4 ;IO wait states
IO_RDY EQU INTRDY ;ignore bus ready
PCS_SPACE EQU IO ;put PCS# chip-selects in I/O space
PCS_FUNC EQU ALLPCS ;generate PCS5# and PCS6#

;The MMCS and MPCS register values are calculated using the above system
;constraints and the equations below:

MMCS_VAL EQU (DRAM_BASE SHL 6) OR (001F8H) OR (DRAM_RDY) OR (DRAM_WAIT)
MPCS_VAL EQU (DRAM_SIZE SHL 5) OR (08038H) OR (PCS_SPACE) OR (PCS_FUNC) OR
& (IO_RDY) OR (IO_WAIT)

;I/O is selected using the PCS0# chip-select. Wait states assume operation at
;16 MHz. For this example, the Floppy Disk Controller is connected to PCS2# and
;PCS1# provides the DACK signal.

IO_BASE EQU 1 ;I/O start address in Kbytes

;The PACS register value is calculated using the above system constraints and
;the equation below.

PACS_VAL EQU (IO_BASE SHL 6) OR (0038H) OR (IO_RDY) OR (IO_WAIT)

;The following statements define the default assumptions for segment locations.

ASSUME CS:CODE
ASSUME DS:DATA
ASSUME SS:DATA
ASSUME ES:DATA

CODE SEGMENT PUBLIC 'CODE'
;
;Entry point on power-up
;
FW_START LABEL FAR ;forces far jump
CLI ;disable interrupts

;Place register initialization code here
;
;Set up chip-selects.
;UCS - EPROM Select (initialized during POWER_ON code)
;LCS - SRAM Select (set to SRAM size)
;PCS - I/O Select (PCS1:0 to support floppy)
;MCS - DRAM Select (set to DRAM size)

mov dx, LMCS_REG ;set up LMCS register
mov ax, LMCS_VAL
out dx, al ;remember that byte writes are OK

```

Example 6-1. Initializing the Chip-Select Unit (Continued)

```

        mov     dx, MPCS_REG           ;ready for PCS lines 4-6
        mov     ax, MPCS_VAL           ;as well as MCS programming
        out     dx, al

        mov     dx, MMCS_REG           ;set up DRAM chip-selects
        mov     ax, MMCS_VAL
        out     dx, al

        mov     dx, PACS_REG           ;set up I/O chip-select
        mov     ax, PACS_VAL
        out     dx, al

CODE     ENDS
;
;Power-on reset code to get started
;
        ASSUME CS:POWER_ON

        POWER_ON SEGMENT AT 0FFFFH

        mov     dx, UMCS_REG           ;point to UMCS register
        mov     ax, UMCS_VAL           ;reprogram UMCS to match system
        out     dx, al                 ;requirements
        jmp     FW_START               ;jump to initialization code
POWER_ON ENDS
;
;Data segment
;
DATA     SEGMENT PUBLIC 'DATA'

        DD     256 DUP (?)             ;reserved for interrupt vectors

;Place memory variables here

        DW     500 DUP (?)             ;stack allocation

STACK_TOP LABEL WORD

DATA     ENDS

;Program ends
        END

```

Example 6-1. Initializing the Chip-Select Unit (Continued)



7

Refresh Control Unit



CHAPTER 7 REFRESH CONTROL UNIT

The Refresh Control Unit (RCU) simplifies dynamic memory controller design with its integrated address and clock counters. Figure 7-1 shows the relationship between the Bus Interface Unit and the Refresh Control Unit. Integrating the Refresh Control Unit into the processor allows an external DRAM controller to use chip-selects, wait state logic and status lines.

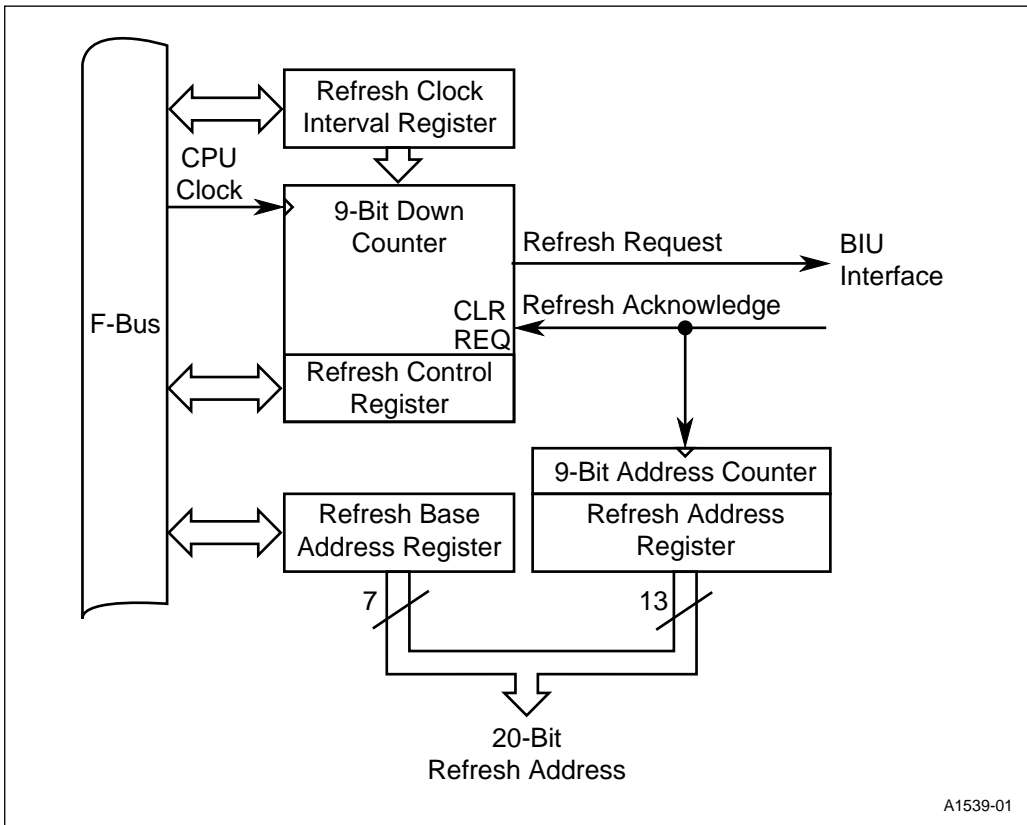

Figure 7-1. Refresh Control Unit Block Diagram

7.1 THE ROLE OF THE REFRESH CONTROL UNIT

Like a DMA controller, the Refresh Control Unit runs bus cycles independent of CPU execution. Unlike a DMA controller, however, the Refresh Control Unit does not run bus cycle bursts nor does it transfer data. The DRAM refresh process refreshes individual DRAM rows in “dummy read” cycles, while cycling through all necessary addresses.

The microprocessor interface to DRAMs is more complicated than other memory interfaces. A complete DRAM controller requires circuitry beyond that provided by the processor even in the simplest configurations. This circuitry must respond correctly to reads, writes and DRAM refresh cycles. The external DRAM controller generates the Row Address Strobe (RAS), Column Address Strobe (CAS) and other DRAM control signals.

Pseudo-static RAMs use dynamic memory cells but generate address strobes and refresh addresses internally. The address counters still need external timing pulses. These pulses are easy to derive from the processor’s bus control signals. Pseudo-static RAMs do not need a full DRAM controller.

7.2 REFRESH CONTROL UNIT CAPABILITIES

A 9-bit address counter forms the refresh addresses, supporting any dynamic memory devices with up to 9 rows of memory cells (9 refresh address bits). This includes all practical DRAM sizes for the processor’s 1 Mbyte address space.

7.3 REFRESH CONTROL UNIT OPERATION

Figure 7-2 illustrates Refresh Control Unit counting, address generation and BIU bus cycle generation in flowchart form.

The nine-bit down-counter loads from the Refresh Interval Register on the falling edge of CLK-OUT. Once loaded, it decrements every falling CLKOUT edge until it reaches one. Then the down-counter reloads and starts counting again, simultaneously triggering a refresh request. Once enabled, the DRAM refresh process continues indefinitely until the user reprograms the Refresh Control Unit, a reset occurs, or the processor enters Powerdown mode. Power-Save mode divides the Refresh Control Unit clocks, so reprogramming the Refresh Interval Register becomes necessary.

The refresh request remains active until the bus becomes available. When the bus is free, the BIU will run its “dummy read” cycle. Refresh bus requests have higher priority than most CPU bus cycles, all DMA bus cycles and all interrupt vectoring sequences. Refresh bus cycles also have a higher priority than the HOLD/HLDA bus arbitration protocol (see “Refresh Operation and Bus HOLD” on page 7-12).

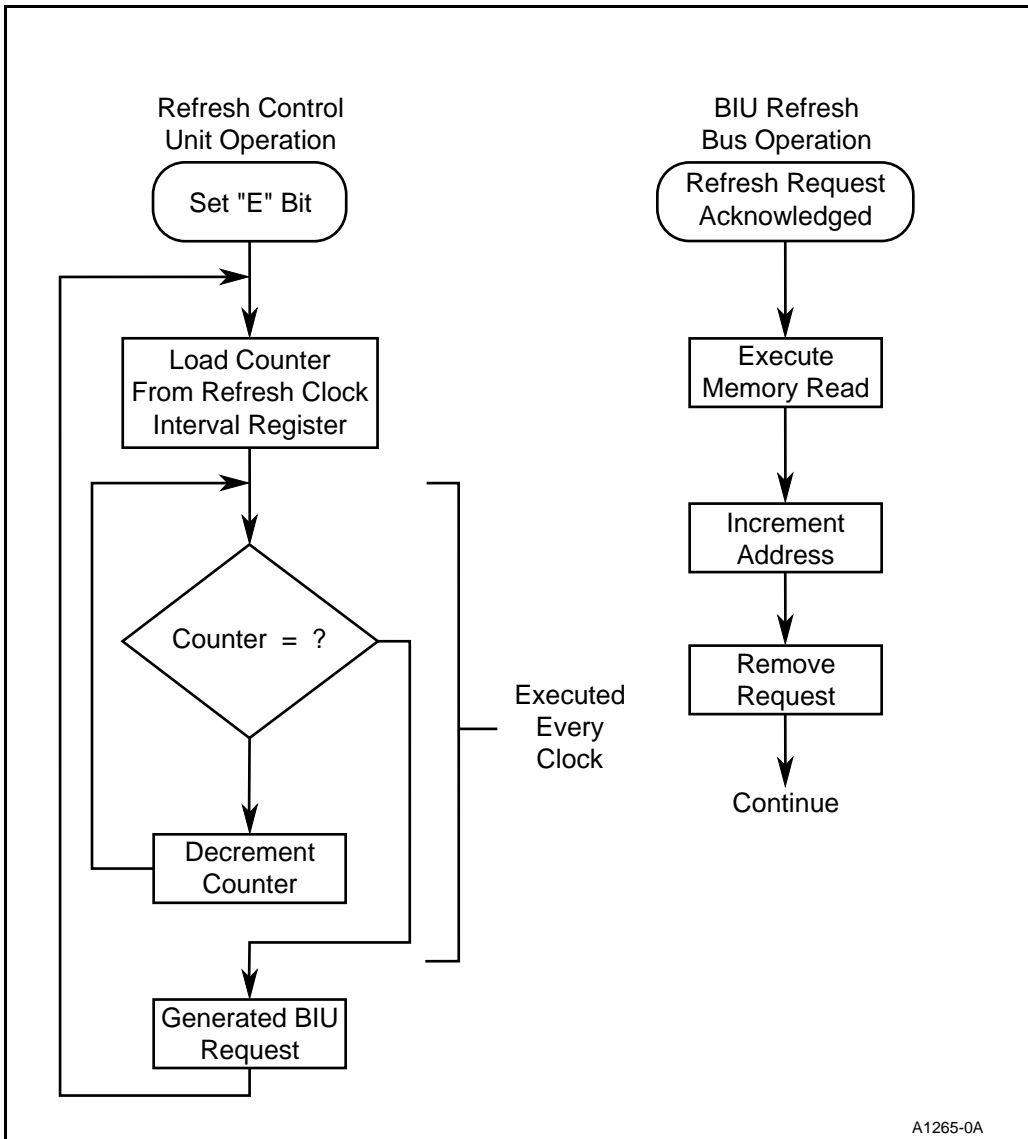

Figure 7-2. Refresh Control Unit Operation Flow Chart

The nine-bit refresh clock counter does not wait until the BIU services the refresh request to continue counting. This operation ensures that refresh requests occur at the correct interval. Otherwise, the time between refresh requests would be a function of varying bus activity. When the BIU services the refresh request, it clears the request and increments the refresh address.

The BIU does not queue DRAM refresh requests. If the Refresh Control Unit generates another request before the BIU handles the present request, the BIU loses the present request. However, the address associated with the request is not lost. The refresh address changes only after the BIU runs a refresh bus cycle. If a DRAM refresh cycle is excessively delayed, there is still a chance that the processor will successfully refresh the corresponding row of cells in the DRAM, retaining the data.

7.4 REFRESH ADDRESSES

Figure 7-3 shows the physical address generated during a refresh bus cycle. This figure applies to both the 8-bit and 16-bit data bus microprocessor versions. Refresh address bits RA19:13 come from the Refresh Base Address Register. (See “Refresh Base Address Register” on page 7-8.)

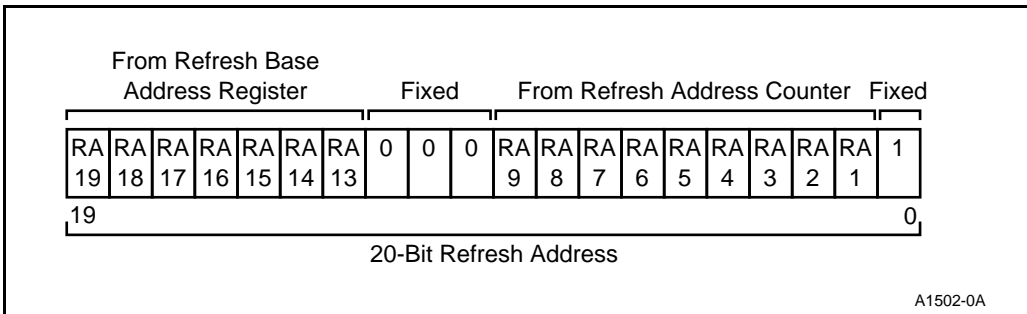

Figure 7-3. Refresh Address Formation

Refresh address bits RA12:10 are always zero. A linear-feedback shift counter generates address bits RA9:1 and RA0 is always one. The counter does not count linearly from 0 through 1FFH. However, the counting algorithm cycles uniquely through all possible 9-bit values. It matters only that each row of DRAM memory cells is refreshed at a specific interval. The order of the rows is unimportant.

Address bit A0 is fixed at one during all refresh operations. In applications based on a 16-bit data bus processor, A0 typically selects memory devices placed on the low (even) half of the bus. Applications based on an 8-bit data bus processor typically use A0 as a true address bit. The DRAM controller must **not** route A0 to row address pins on the DRAMs.

7.5 REFRESH BUS CYCLES

Refresh bus cycles look exactly like ordinary memory read bus cycles except for the control signals listed in Table 7-1. These signals can be ANDed in a DRAM controller to detect a refresh bus cycle. The 16-bit bus processor drives both the $\overline{\text{BHE}}$ and A0 pins high during refresh cycles. The 8-bit bus version replaces the $\overline{\text{BHE}}$ pin with $\overline{\text{RFSH}}$, which has the same timings. The 8-bit bus processor drives $\overline{\text{RFSH}}$ low and A0 high during refresh cycles.

Table 7-1. Identification of Refresh Bus Cycles

Data Bus Width	$\overline{\text{BHE}}/\overline{\text{RFSH}}$	A0
16-Bit Device	1	1
8-Bit Device	0	1

7.6 GUIDELINES FOR DESIGNING DRAM CONTROLLERS

The basic DRAM access method consists of four phases:

1. The DRAM controller supplies a row address to the DRAMs.
2. The DRAM controller asserts a Row Address Strobe ($\overline{\text{RAS}}$), which latches the row address inside the DRAMs.
3. The DRAM controller supplies a column address to the DRAMs.
4. The DRAM controller asserts a Column Address Strobe ($\overline{\text{CAS}}$), which latches the column address inside the DRAMs.

Most 80C186 Modular Core family DRAM interfaces use only this method. Others are not discussed here.

The DRAM controller's purpose is to use the processor's address, status and control lines to generate the multiplexed addresses and strobes. These signals must be appropriate for three bus cycle types: read, write and refresh. They must also meet specific pulse width, setup and hold timing requirements. DRAM interface designs need special attention to transmission line effects, since DRAMs represent significant loads on the bus.

DRAM controllers may be either clocked or unclocked. An unclocked DRAM controller requires a tapped digital delay line to derive the proper timings.

Clocked DRAM controllers may use either discrete or programmable logic devices. A state machine design is appropriate, especially if the circuit must provide wait state control (beyond that possible with the processor's Chip-Select Unit). Because of the microprocessor's four-clock bus, clocking some logic elements on each CLKOUT phase is advantageous (see Figure 7-4).

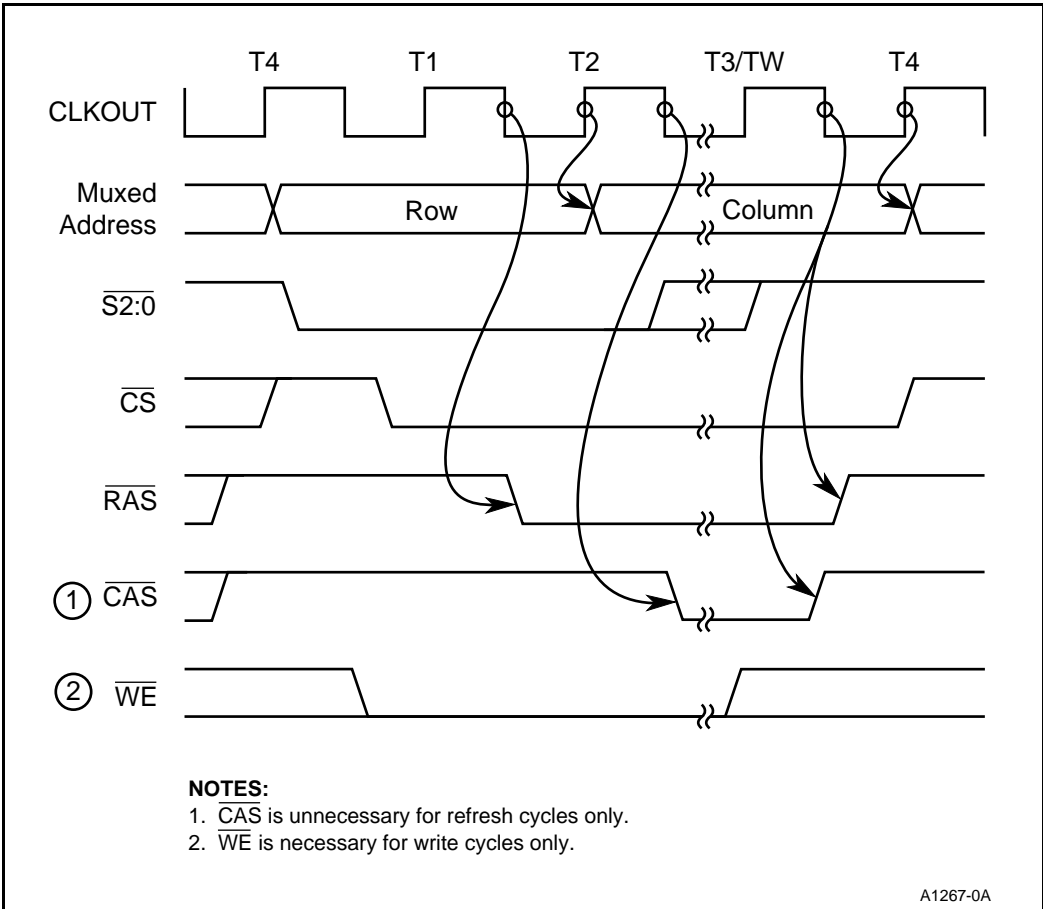

Figure 7-4. Suggested DRAM Control Signal Timing Relationships

The cycle begins with presentation of the row address. \overline{RAS} should go active on the falling edge of T2. At the rising edge of T2, the address lines should switch to a column address. \overline{CAS} goes active on the falling edge of T3. Refresh cycles do not require \overline{CAS} . When \overline{CAS} is present, the “dummy read” cycle becomes a true read cycle (the DRAM drives the bus), and the DRAM row still gets refreshed.

Both \overline{RAS} and \overline{CAS} stay active during any wait states. They go inactive on the falling edge of T4. At the rising edge of T4, the address multiplexer shifts to its original selection (row addressing), preparing for the next DRAM access.

7.7 PROGRAMMING THE REFRESH CONTROL UNIT

Given a specific processor operating frequency and information about the DRAMs in the system, the user can program the Refresh Control Unit registers.

7.7.1 Calculating the Refresh Interval

DRAM data sheets show DRAM refresh requirements as a number of refresh cycles necessary and the maximum period to run the cycles. (The number of refresh cycles is the same as the number of rows.) You must compensate for bus latency — the time it takes for the Refresh Control Unit to gain control of the bus. This is typically 1–5%, but if an external bus master will be extremely slow to release the bus, increase the overhead percentage. At standard operating frequencies, DRAM refresh bus overhead totals 2–3% of the total bus bandwidth.

Given this information and the CPU operating frequency, use the formula in Figure 7-5 to determine the correct value for the RFTIME Register value.

$\frac{R_{\text{PERIOD}} \times F_{\text{CPU}}}{\text{Rows} + (\text{Rows} \times \text{Overhead}\%)} = \text{RFTIME Register Value}$	
R_{PERIOD}	= Maximum refresh period specified by DRAM manufacturer (in μs).
F_{CPU}	= Operating frequency (in MHz).
ROWS	= Total number of rows to be refreshed.
Overhead %	= Derating factor to compensate for missed refresh requests (typically 1–5 %).

Figure 7-5. Formula for Calculating Refresh Interval for RFTIME Register

If the processor enters Power-Save mode, the refresh rate must increase to offset the reduced CPU clock rate to preserve memory. At lower frequencies, the refresh bus overhead increases. At frequencies less than about 1.5 MHz, the Bus Interface Unit will spend almost all its time running refresh cycles. There may not be enough bandwidth left for the processor to perform other activities, especially if the processor must share the bus with an external master.

7.7.2 Refresh Control Unit Registers

Three contiguous Peripheral Control Block registers operate the Refresh Control Unit: the Refresh Base Address Register, Refresh Clock Interval Register and the Refresh Control Register.

7.7.2.1 Refresh Base Address Register

The Refresh Base Address Register (Figure 7-6) programs the base (upper seven bits) of the refresh address. Seven-bit mapping places the refresh address at any 4 Kbyte boundary within the 1 Mbyte address space. When the partial refresh address from the 9-bit address counter (see Figure 7-1 and “Refresh Control Unit Capabilities” on page 7-2) passes 1FFH, the Refresh Control Unit does **not** increment the refresh base address. Setting the base address ensures that the address driven during a refresh bus cycle activates the DRAM chip select.

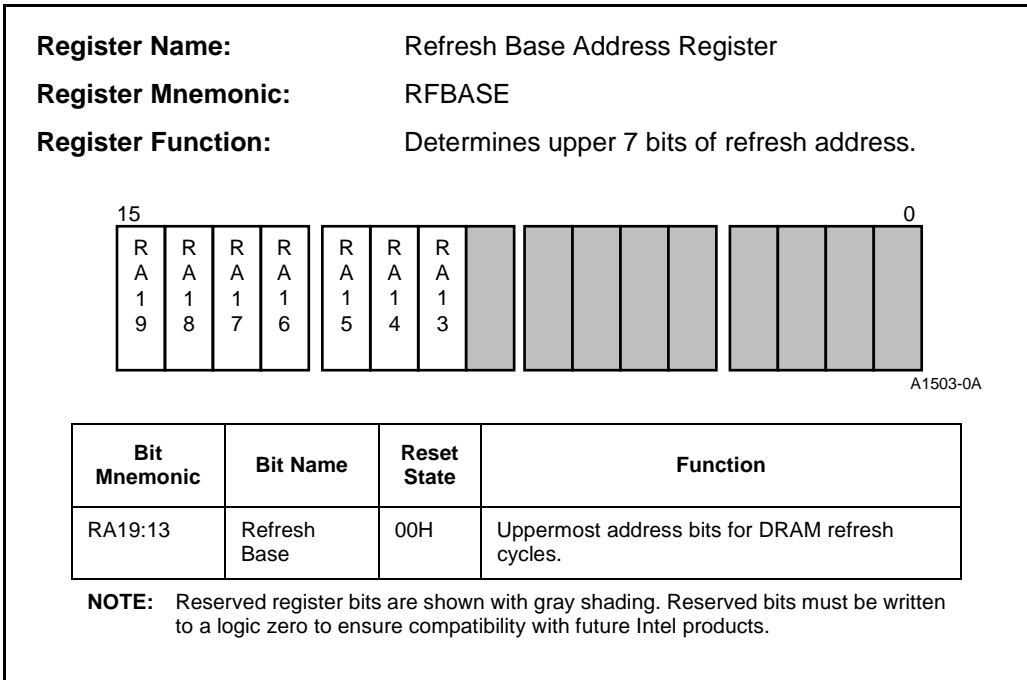
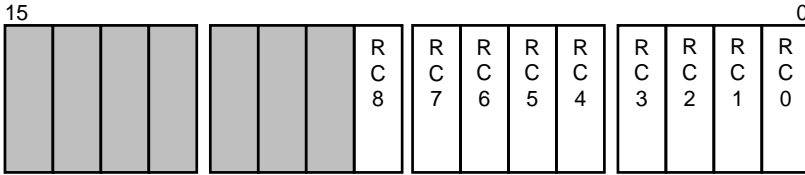

Figure 7-6. Refresh Base Address Register

7.7.2.2 Refresh Clock Interval Register

The Refresh Clock Interval Register (Figure 7-7) defines the time between refresh requests. The higher the value, the longer the time between requests. The down-counter decrements every falling CLKOUT edge, regardless of core activity. When the counter reaches one, the Refresh Control Unit generates a refresh request, and the counter reloads the value from the register. Since Power-Save mode divides the clock to the Refresh Control Unit, this register will require reprogramming if Power-Save mode is used.

Register Name: Refresh Clock Interval Register
Register Mnemonic: RFTIME
Register Function: Sets refresh rate.



A1288-0A

Bit Mnemonic	Bit Name	Reset State	Function
RC8:0	Refresh Counter Reload Value	000H	Sets the desired clock count between refresh cycles.

NOTE: Reserved register bits are shown with gray shading. Reserved bits must be written to a logic zero to ensure compatibility with future Intel products.

Figure 7-7. Refresh Clock Interval Register

7.7.2.3 Refresh Control Register

Figure 7-8 shows the Refresh Control Register. The user may read or write the REN bit at any time to turn the Refresh Control Unit on or off. The lower nine bits contain the current nine-bit down-counter value. **The user cannot program these bits.** Disabling the Refresh Control Unit clears both the counter and the corresponding counter bits in the control register.

Register Name: Refresh Control Register
Register Mnemonic: RFCON
Register Function: Controls Refresh Unit operation.

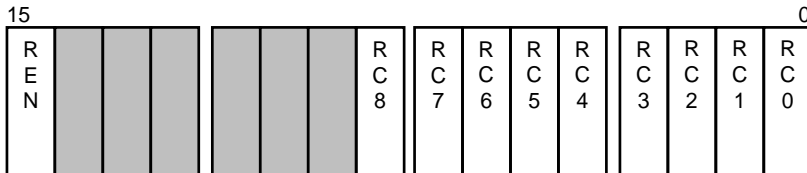

A1311-0A

Bit Mnemonic	Bit Name	Reset State	Function
REN	Refresh Control Unit Enable	0	Setting REN enables the Refresh Unit. Clearing REN disables the Refresh Unit.
RC8:0	Refresh Counter	000H	These bits contain the present value of the down-counter that triggers refresh requests. The user cannot program these bits.

NOTE: Reserved register bits are shown with gray shading. Reserved bits must be written to a logic zero to ensure compatibility with future Intel products.

Figure 7-8. Refresh Control Register

7.7.3 Programming Example

Example 7-1 contains sample code to initialize the Refresh Control Unit. Example 5-2 on page 5-22 shows the additional code to reprogram the Refresh Control Unit upon entering Power-Save mode.

```

$mod186
name                example_80C186_RCU_code

; FUNCTION:  This function initializes the DRAM Refresh
; Control Unit to refresh the DRAM starting at dram_addr
; at clock_time intervals.

; SYNTAX:
; extern void far config_rcu(int dram_addr, int clock_time);

; INPUTS:    dram_addr - Base address of DRAM to refresh
;            clock_time - DRAM refresh rate

; OUTPUTS:   None

;            NOTE:  Parameters are passed on the stack as
;            required by high-level languages.

RFBASE             equ   xxxxxh                ;substitute register offset
RFTIME             equ   xxxxxh
RFCON              equ   xxxxxh
Enable             equ   8000h                ;enable bit

lib_80186          segment public 'code'
                  assume cs:lib_80186

                  public _config_rcu
_config_rcu        proc far

                  push bp                      ;save caller's bp
                  mov  bp, sp                 ;get current top of stack

_clock_time       equ   word ptr[bp+6]        ;get parameters off
_dram_addr        equ   word ptr[bp+8]        ;the stack

                  push ax                      ;save registers that
                  push cx                      ;will be modified
                  push dx
                  push di

```

Example 7-1. Initializing the Refresh Control Unit

```

        mov dx, RFBASE           ;set upper 7 address bits
        mov ax, _dram_addr
        out dx, al

        mov dx, RFTIME          ;set clock pre_scaler
        mov ax, _clock_time
        out dx, al

        mov dx, RFCON           ;Enable RCU
        mov ax, Enable
        out dx, al

        mov cx, 8               ;8 dummy cycles are
                                ;required by DRAMs
        xor di, di              ;before actual use

_exercise_ram:
        mov word ptr [di], 0
        loop _exercise_ram

        pop di                  ;restore saved registers
        pop dx
        pop cx
        pop ax
        pop bp                  ;restore caller's bp

        ret
_config_rcu   endp
lib_80186    ends
end

```

Example 7-1. Initializing the Refresh Control Unit (Continued)

7.8 REFRESH OPERATION AND BUS HOLD

When another bus master controls the bus, the processor keeps $\overline{\text{HLD\!A}}$ active as long as the HOLD input remains active. If the Refresh Control Unit generates a refresh request during bus hold, the processor drives the $\overline{\text{HLD\!A}}$ signal inactive, indicating to the current bus master that it wishes to regain bus control (see Figure 7-9). The BIU begins a refresh bus cycle only after the alternate master removes HOLD. The user must design the system so that the processor can regain bus control. If the alternate master asserts HOLD after the processor starts the refresh cycle, the CPU will relinquish control by asserting $\overline{\text{HLD\!A}}$ when the refresh cycle is complete.

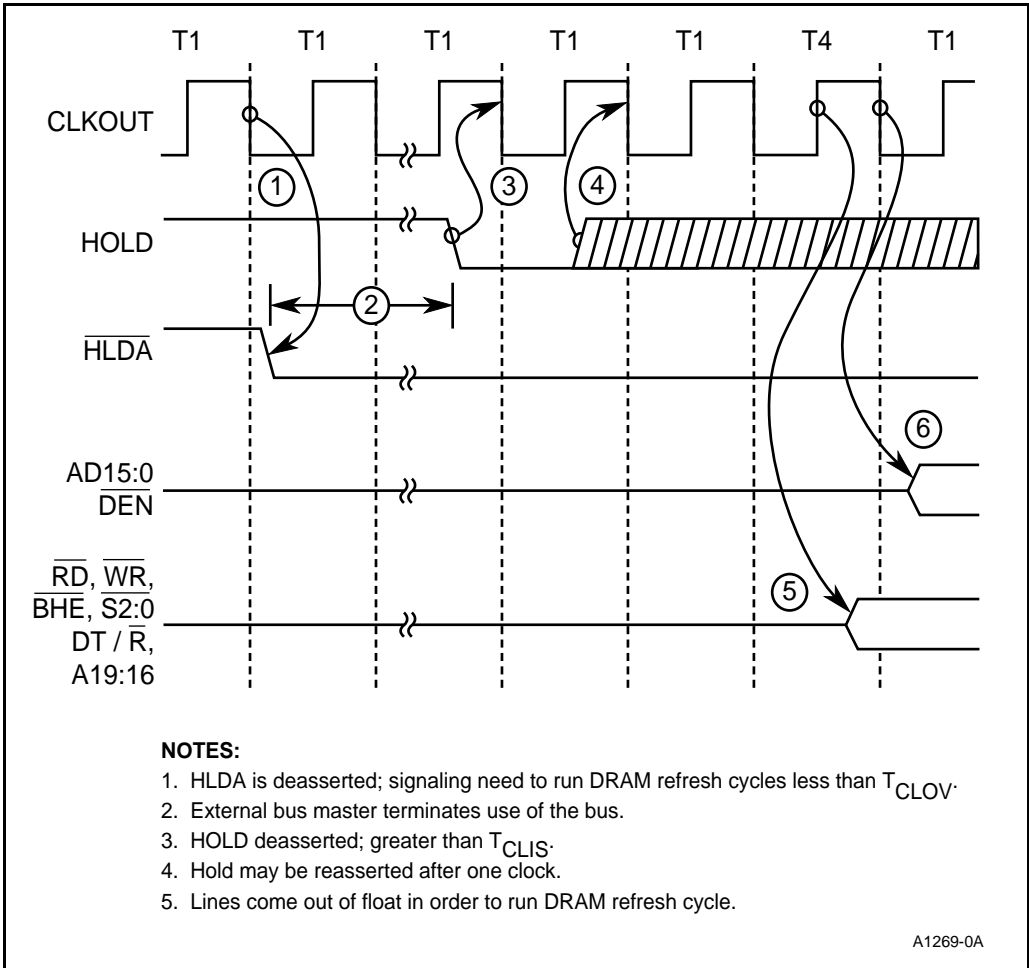

Figure 7-9. Regaining Bus Control to Run a DRAM Refresh Bus Cycle



8

Interrupt Control Unit



CHAPTER 8

INTERRUPT CONTROL UNIT

The 80C186 Modular Core has a single maskable interrupt input. (See “Interrupts and Exception Handling” on page 2-39.) The Interrupt Control Unit (ICU) expands the interrupt capabilities beyond a single input. To fulfill this function, the Interrupt Control Unit operates in either of two modes: Master or Slave.

In Master mode, the ICU controls the maskable interrupt input to the CPU. Interrupts can originate from the on-chip peripherals and from four external interrupt pins. The ICU synchronizes and prioritizes all interrupt sources and presents the correct interrupt type vector to the CPU. (See Figure 8-1.) Most systems use master mode.

In Slave mode, an external 8259A module controls the maskable interrupt input to the CPU and acts as the master interrupt controller. The ICU processes only those interrupts from the on-chip peripherals and acts as an interrupt input to the 8259A. (See Figure 8-15 on page 8-24.) This mode can be useful in larger system designs.

The Interrupt Control Unit has the following features:

- Programmable priority of each interrupt source
- Individual masking of each interrupt source
- Nesting of interrupt sources
- Support for polled operation
- Support for cascading external 8259A modules to expand external interrupt sources

8.1 FUNCTIONAL OVERVIEW

All microcomputer systems must communicate in some way with the external world. A typical system might have a keyboard, a disk drive and a communications port, all requiring CPU attention at different times. There are two distinct ways to process peripheral I/O requests: polling and interrupts.

Polling requires that the CPU check each peripheral device in the system periodically to see whether it requires servicing. It would not be unusual to poll a low-speed peripheral (a serial port, for instance) thousands of times before it required servicing. In most cases, the use of polling has a detrimental effect on system throughput. Any time used to check the peripherals is time spent away from the main processing tasks.

Interrupts eliminate the need for polling by signalling the CPU that a peripheral device requires servicing. The CPU then stops executing the main task, saves its state and transfers execution to the peripheral-servicing code (the *interrupt handler*). At the end of the interrupt handler, the CPU's original state is restored and execution continues at the point of interruption in the main task.

8.2 MASTER MODE

Figure 8-1 shows a block diagram of the Interrupt Control Unit in Master mode. In this mode, the ICU processes all interrupt requests, both external and internal. The three timer interrupt requests share a single input, while the others are supported directly.

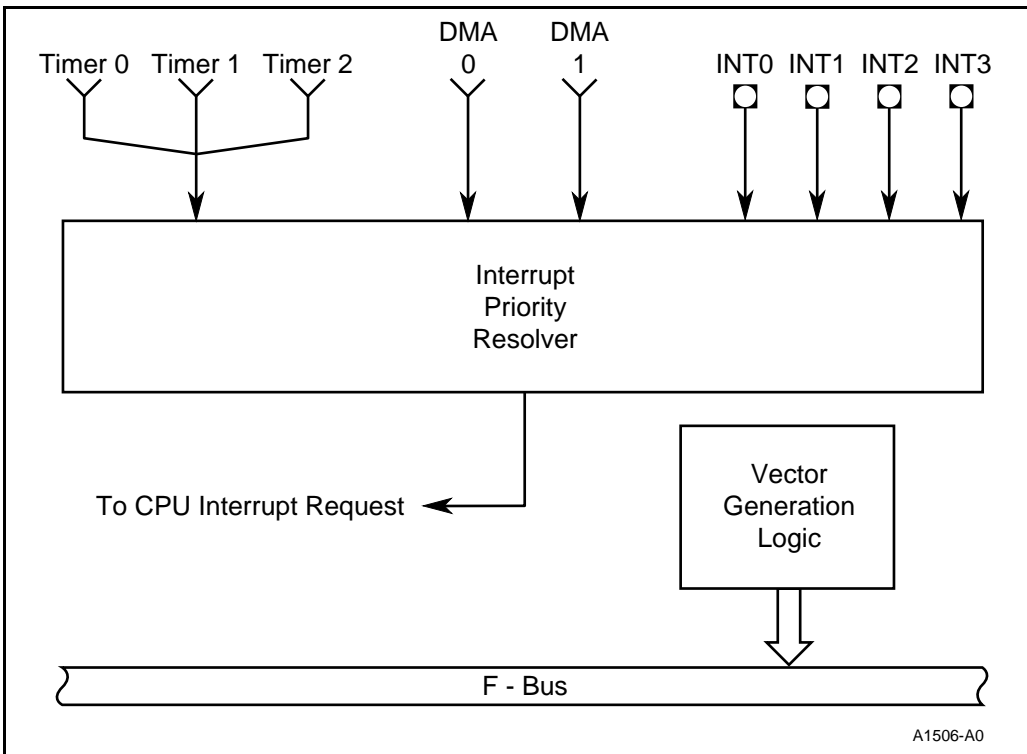

Figure 8-1. Interrupt Control Unit in Master Mode

8.2.1 Generic Functions in Master Mode

Several functions of the Interrupt Control Unit are common among most interrupt controllers. This section describes how those generic functions are implemented in the Interrupt Control Unit.

8.2.1.1 Interrupt Masking

There are circumstances in which a programmer may need to disable an interrupt source temporarily (for example, while executing a time-critical section of code or servicing a high-priority task). This temporary disabling is called interrupt masking. All interrupts from the Interrupt Control Unit can be masked either globally or individually.

The Interrupt Enable bit in the Processor Status Word globally enables or disables the maskable interrupt request from the Interrupt Control Unit. The programmer controls the Interrupt Enable bit with the STI (set interrupt) and CLI (clear interrupt) instructions.

Besides being globally enabled or disabled by the Interrupt Enable bit, each interrupt source can be individually enabled or disabled. The Interrupt Mask register has a single bit for each interrupt source. The programming can selectively mask (disable) or unmask (enable) each interrupt source by setting or clearing the corresponding bit in the Interrupt Mask register.

8.2.1.2 Interrupt Priority

One critical function of the Interrupt Control Unit is to prioritize interrupt requests. When multiple interrupts are pending, priority determines which interrupt request is serviced first. In many systems, an interrupt handler may itself be interrupted by another interrupt source. This is known as *interrupt nesting*. With interrupt nesting, priority determines whether an interrupt source can preempt an interrupt handler that is currently executing.

Each interrupt source is assigned a priority between zero (highest) and seven (lowest). After reset, the interrupts default to the priorities shown in Table 8-1. Because the timers share an interrupt source, they also share a priority. Within the assigned priority, each has a relative priority (Timer 0 has the highest relative priority and Timer 2 has the lowest).

Table 8-1. Default Interrupt Priorities

Interrupt Name	Relative Priority
Timer 0	0 (a)
Timer 1	0 (b)
Timer 2	0 (c)
DMA0	1
DMA1	2
INT0	3
INT1	4
INT2	5
INT3	6

The priority of each source is programmable. The Interrupt Control register enables the programmer to assign each source a priority that differs from the default. The priority must still be between zero (highest) and seven (lowest). Interrupt sources can be programmed to share a priority. The Interrupt Control Unit uses the default priorities (see Table 8-1) within the shared priority level to determine which interrupt to service first. For example, assume that INT0 and INT1 are both programmed to priority seven. Because INT0 has the higher default priority, it is serviced first.

Interrupt sources can be masked on the basis of their priority. The Priority Mask register masks all interrupts with priorities lower than its programmed value. After reset, the Priority Mask register contains priority seven, which effectively enables all interrupts. The programmer can then program the register with any valid priority level.

8.2.1.3 Interrupt Nesting

When entering an interrupt handler, the CPU pushes the Processor Status Word onto the stack and clears the Interrupt Enable bit. The processor enters all interrupt handlers with maskable interrupts disabled. Maskable interrupts remain disabled until either the IRET instruction restores the Interrupt Enable bit or the programmer explicitly enables interrupts. Enabling maskable interrupts within an interrupt handler allows interrupts to be nested. Otherwise, interrupts are processed sequentially; one interrupt handler must finish before another executes.

The simplest way to use the Interrupt Control Unit is without nesting. The operation and servicing of all sources of maskable interrupts is straightforward. However, the application trade-off is that an interrupt handler will finish executing even if a higher priority interrupt occurs. This can add considerable latency to the higher priority interrupt.

In the simplest terms, the Interrupt Control Unit asserts the maskable interrupt request to the CPU, waits for the interrupt acknowledge, then presents the interrupt type of the highest priority unmasked interrupt to the CPU. The CPU then executes the interrupt handler for that interrupt. Because the interrupt handler never sets the Interrupt Enable bit, it can never be interrupted.

The function of the Interrupt Control Unit is more complicated with interrupt nesting. In this case, an interrupt can occur during execution of an interrupt handler. That is, one interrupt can *preempt* another. Two rules apply for interrupt nesting:

- An interrupt source cannot preempt interrupts of higher priority.
- An interrupt source cannot preempt itself. The interrupt handler must finish executing before the interrupt is serviced again. (Special Fully Nested Mode is an exception. See “Special Fully Nested Mode” on page 8-8.)

8.3 FUNCTIONAL OPERATION IN MASTER MODE

This section covers the process in which the Interrupt Control Unit receives interrupts and asserts the maskable interrupt request to the CPU.

8.3.1 Typical Interrupt Sequence

When the Interrupt Control Unit first detects an interrupt, it sets the corresponding bit in the Interrupt Request register to indicate that the interrupt is pending. The Interrupt Control Unit checks all pending interrupt sources. If the interrupt is unmasked and meets the priority criteria (see “Priority Resolution” on page 8-5), the Interrupt Control Unit asserts the maskable interrupt request to the CPU, then waits for the interrupt acknowledge.

When the Interrupt Control Unit receives the interrupt acknowledge, it passes the interrupt type to the CPU. At that point, the CPU begins the interrupt processing sequence. (See “Interrupt/Exception Processing” on page 2-39 for details.) The Interrupt Control Unit always passes the vector that has the highest priority at the time the acknowledge is received. If a higher priority interrupt occurs before the interrupt acknowledge, the higher priority interrupt has precedence.

When it receives the interrupt acknowledge, the Interrupt Control Unit clears the corresponding bit in the Interrupt Request register and sets the corresponding bit in the In-Service register. The In-Service register keeps track of which interrupt handlers are being processed. At the end of an interrupt handler, the programmer must issue an End-of-Interrupt (EOI) command to explicitly clear the In-Service register bit. If the bit remains set, the Interrupt Control Unit **cannot** process any additional interrupts from that source.

8.3.2 Priority Resolution

The decision to assert the maskable interrupt request to the CPU is somewhat complicated. The complexity is needed to support interrupt nesting. First, an interrupt occurs and the corresponding Interrupt Request register bit is set. The Interrupt Control Unit then asserts the maskable interrupt request to the CPU, if the pending interrupt satisfies these requirements:

1. its Interrupt Mask bit is cleared (it is unmasked)
2. its priority is higher than the value in the Priority Mask register
3. its In-Service bit is cleared
4. its priority is equal to or greater than that of any interrupt whose In-Service bit is set

The In-Service register keeps track of interrupt handler execution. The Interrupt Control Unit uses this information to decide whether another interrupt source has sufficient priority to preempt an interrupt handler that is executing.

8.3.2.1 Priority Resolution Example

This example illustrates priority resolution. Assume these initial conditions:

- the Interrupt Control Unit has been initialized
- no interrupts are pending
- no In-Service bits are set
- the Interrupt Enable bit is set
- all interrupts are unmasked
- the default priority scheme is being used
- the Priority Mask register is set to the lowest priority (seven)

The example uses two external interrupt sources, INT0 and INT3, to describe the process.

1. A low-to-high transition on INT0 sets its Interrupt Request bit. The interrupt is now pending.
2. Because INT0 is the only pending interrupt, it meets all the priority criteria. The Interrupt Control Unit asserts the interrupt request to the CPU and waits for an acknowledge.
3. The CPU acknowledges the interrupt.
4. The Interrupt Control Unit passes the interrupt type (in this case, type 12) to the CPU.
5. The Interrupt Control Unit clears the INT0 bit in the Interrupt Request register and sets the INT0 bit in the In-Service register.
6. The CPU executes the interrupt processing sequence and begins executing the interrupt handler for INT0.
7. During execution of the INT0 interrupt handler, a low-to-high transition on INT3 sets its Interrupt Request bit.
8. The Interrupt Control Unit determines that INT3 has a lower priority than INT0, which is currently executing (INT0's In-Service bit is set). INT3 does not meet the priority criteria, so no interrupt request is sent to the CPU. (If INT3 were programmed with a higher priority than INT0, the request would be sent.) INT3 remains pending in the Interrupt Request register.
9. The INT0 interrupt handler completes and sends an EOI command to clear the INT0 bit in the In-Service register.
10. INT3 is still pending and now meets all the priority criteria. The Interrupt Control Unit asserts the interrupt request to the CPU and the process begins again.

8.3.2.2 Interrupts That Share a Single Source

Multiple interrupt requests can share a single interrupt input to the Interrupt Control Unit. (For example, the three timers share a single input.) Although these interrupts share an input, each has its own interrupt vector. (For example, when a Timer 0 interrupt occurs, the Timer 0 interrupt handler is executed.) This section uses the three timers as an example to describe how these interrupts are prioritized and serviced.

The Interrupt Status register acts as a second-level request register to process the timer interrupts. It contains a bit for each timer interrupt. When a timer interrupt occurs, both the individual Interrupt Status register bit and the shared Interrupt Request register bit are set. From this point, the interrupt is processed like any other interrupt source.

When the shared interrupt is acknowledged, the timer interrupt with the highest priority (see Table 8-1 on page 8-3) **at that time** is serviced first and that timer's Interrupt Status bit is cleared. If no other timer Interrupt Status bits are set, the shared Interrupt Request bit is also cleared. If other timer interrupts are pending, the Interrupt Request bit remains set.

When the timer interrupt is acknowledged, the shared In-Service bit is set. **No other timer interrupts can occur when the In-Service bit is set.** If a second timer interrupt occurs while another timer interrupt is being serviced, the second interrupt remains pending until the interrupt handler for the first interrupt finishes and clears the In-Service bit. (This is true even if the second interrupt has a higher priority than the first.)

8.3.3 Cascading with External 8259As

For applications that require more external interrupt pins than the number provided on the Interrupt Control Unit, external 8259A modules can be used to increase the number of external interrupt pins. The cascade mode of the Interrupt Control Unit supports the external 8259As. The $\overline{\text{INT2/INTA0}}$ and $\overline{\text{INT3/INTA1}}$ pins can serve either of two functions. Outside cascade mode, they serve as external interrupt inputs. In cascade mode, they serve as interrupt acknowledge outputs. $\overline{\text{INTA0}}$ is the acknowledge for INT0 , and $\overline{\text{INTA1}}$ is the acknowledge for INT1 . (See Figure 8-2.)

The $\overline{\text{INT2/INTA0}}$ and $\overline{\text{INT3/INTA1}}$ pins are inputs after reset until the pins are configured as outputs. The pullup resistors ensure that the $\overline{\text{INTA}}$ pins never float (which would cause a spurious interrupt acknowledge to the 8259A). The value of the resistors must be high enough to prevent excessive loading on the pins.

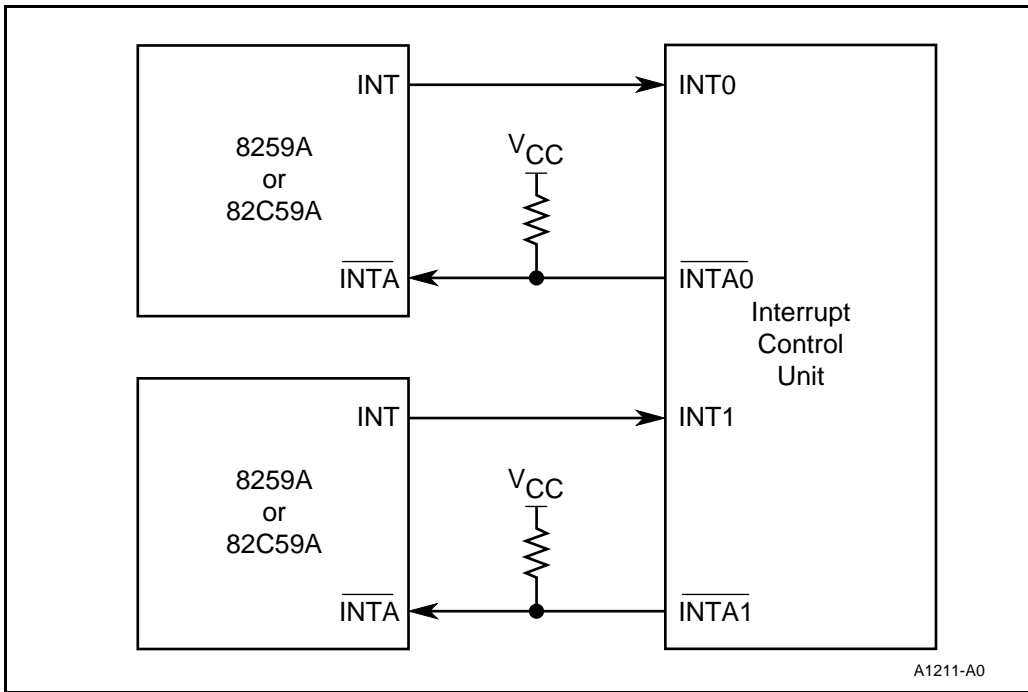

Figure 8-2. Using External 8259A Modules in Cascade Mode

8.3.3.1 Special Fully Nested Mode

Special fully nested mode is an optional feature normally used with cascade mode. It is applicable only to INT0 and INT1. In special fully nested mode, an interrupt request is serviced even if its In-Service bit is set.

In cascade mode, an 8259A controls up to eight external interrupts that share a single interrupt input pin. Special fully nested mode allows the 8259A's priority structure to be maintained. For example, assume that the CPU is servicing a low-priority interrupt from the 8259A. While the interrupt handler is executing, the 8259A receives a higher priority interrupt from one of its sources. The 8259A applies its own priority criteria to that interrupt and asserts its interrupt to the Interrupt Control Unit. Special fully nested mode allows the higher priority interrupt to be serviced even though the In-Service bit for that source is already set. A higher priority interrupt has preempted a lower priority interrupt, and interrupt nesting is fully maintained.

Special fully nested mode can also be used without cascade mode. In this case, it allows a single external interrupt pin (either INT0 or INT1) to preempt itself.

8.3.4 Interrupt Acknowledge Sequence

During the interrupt acknowledge sequence, the Interrupt Control Unit passes the interrupt type to the CPU. The CPU then multiplies the interrupt type by four to derive the interrupt vector address in the interrupt vector table. (“Interrupt/Exception Processing” on page 2-39 describes the interrupt acknowledge sequence and Figure 2-25 on page 2-40 illustrates the interrupt vector table.)

The interrupt types for all sources are fixed and unalterable (see Table 8-2). The Interrupt Control Unit passes these types to the CPU internally. The first external indication of the interrupt acknowledge sequence is the CPU fetch from the interrupt vector table.

In cascade mode, the external 8259A supplies the interrupt type. In this case, the CPU runs an external interrupt acknowledge cycle to fetch the interrupt type from the 8259A (see “Interrupt Acknowledge Bus Cycle” on page 3-25).

Table 8-2. Fixed Interrupt Types

Interrupt Name	Interrupt Type
Timer 0	8
Timer 1	18
Timer 2	19
DMA0	10
DMA1	11
INT0	12
INT1	13
INT2	14
INT3	15

8.3.5 Polling

In some applications, it is desirable to poll the Interrupt Control Unit. The CPU polls the Interrupt Control Unit for any pending interrupts, and software can service interrupts whenever it is convenient. The Poll and Poll Status registers support polling.

Software reads the Poll register to get the type of the highest priority pending interrupt, then calls the corresponding interrupt handler. Reading the Poll register also acknowledges the interrupt. This clears the Interrupt Request bit and sets the In-Service bit for the interrupt. The Poll Status register has the same format as the Poll register, but reading the Poll Status register does **not** acknowledge the interrupt.

8.3.6 Edge and Level Triggering

The external interrupts (INT3:0) can be programmed for either edge or level triggering (see “Interrupt Control Registers” on page 8-12). Both types of triggering are active high. An edge-triggered interrupt is generated by a zero-to-one transition on an external interrupt pin. The pin must remain high until after the CPU acknowledges the interrupt, then must go low to reset the edge-detection circuitry. (See the current data sheet for timing requirements.) The edge-detection circuitry must be reset to enable further interrupts to occur.

A level-triggered interrupt is generated by a valid logic one on the external interrupt pin. The pin must remain high until after the CPU acknowledges the interrupt. Unlike edge-triggered interrupts, level-triggered interrupts will continue to occur if the pin remains high. A level-triggered external interrupt pin must go low before the EOI command to prevent another interrupt.

NOTE

When external 8259As are cascaded into the Interrupt Control Unit, INT0 and INT1 must be programmed for level-triggered interrupts.

8.3.7 Additional Latency and Response Time

The Interrupt Control Unit adds 5 clocks to the interrupt latency of the CPU. Cascade mode adds 13 clocks to the interrupt response time because the CPU must run the interrupt acknowledge bus cycles. (See Figure 8-3 on page 8-11 and Figure 2-27 on page 2-46.)

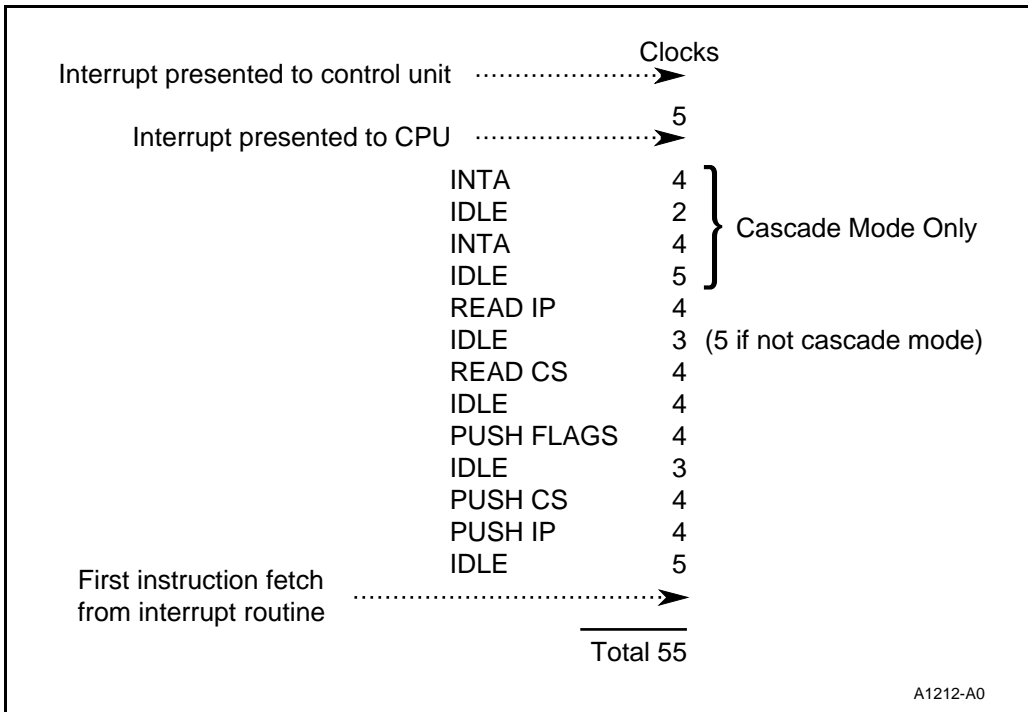

Figure 8-3. Interrupt Control Unit Latency and Response Time

8.4 PROGRAMMING THE INTERRUPT CONTROL UNIT

Table 8-3 lists the Interrupt Control Unit registers in master mode with their Peripheral Control Block offset addresses. The remainder of this section describes the functions of the registers.

Table 8-3. Interrupt Control Unit Registers in Master Mode

Register Name	Offset Address
INT3 Control	3EH
INT2 Control	3CH
INT1 Control	3AH
INT0 Control	38H
DMA0 Control	34H
DMA1 Control	36H
Timer Control	32H
Interrupt Status	30H
Interrupt Request	2EH

Table 8-3. Interrupt Control Unit Registers in Master Mode (Continued)

Register Name	Offset Address
In-Service	2CH
Priority Mask	2AH
Interrupt Mask	28H
Poll Status	26H
Poll	24H
EOI	22H

8.4.1 Interrupt Control Registers

Each interrupt source has its own Interrupt Control register. The Interrupt Control register allows you to define the behavior of each interrupt source. Figure 8-4 shows the registers for the timers and DMA channels, Figure 8-5 shows the registers for INT3:2, and Figure 8-6 shows the registers for INT0 and INT1.

All Interrupt Control registers have a three-bit field (PM2:0) that defines the priority level for the interrupt source and a mask bit (MSK) that enables or disables the interrupt source. The mask bit is the same as the one in the Interrupt Mask register. Modifying a bit in either register also modifies that same bit in the other register.

The Interrupt Control registers for the external interrupt pins also have a bit (LVL) that selects level-triggered or edge-triggered mode for that interrupt. (See “Edge and Level Triggering” on page 8-10.)

The Interrupt Control registers for the cascadable external interrupt pins (INT0 and INT1) have two additional bits to support the external 8259As. The CAS bit enables cascade mode, and the SFNM bit enables special fully nested mode.

Register Name: Interrupt Control Register (internal sources)
Register Mnemonic: TCUCON, DMA0CON, DMA1CON
Register Function: Control register for the internal interrupt sources

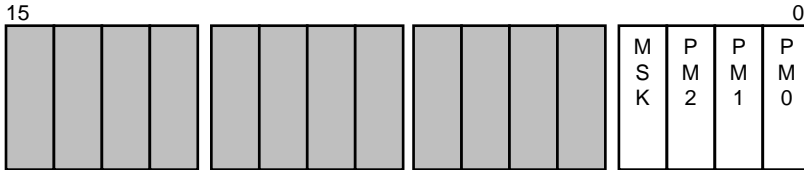

A1213-A0

Bit Mnemonic	Bit Name	Reset State	Function
MSK	Interrupt Mask	1	Clear to enable interrupts from this source.
PM2:0	Priority Level	111	Defines the priority level for this source.

NOTE: Reserved register bits are shown with gray shading. Reserved bits must be written to a logic zero to ensure compatibility with future Intel products.

Figure 8-4. Interrupt Control Register for Internal Sources

Register Name: Interrupt Control Register (non-cascadable pins)
Register Mnemonic: I2CON, I3CON
Register Function: Control register for the non-cascadable external internal interrupt pins

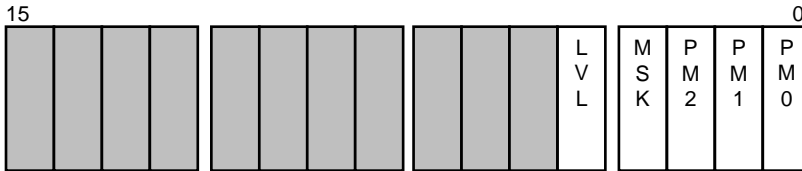

A1214-A0

Bit Mnemonic	Bit Name	Reset State	Function
LVL	Level-trigger	0	Selects the interrupt triggering mode: 0 = edge triggering 1 = level triggering.
MSK	Interrupt Mask	1	Clear to enable interrupts from this source.
PM2:0	Priority Level	111	Defines the priority level for this source.

NOTE: Reserved register bits are shown with gray shading. Reserved bits must be written to a logic zero to ensure compatibility with future Intel products.

Figure 8-5. Interrupt Control Register for Noncascadable External Pins

Register Name: Interrupt Control Register (cascadable pins)
Register Mnemonic: IOCON, I1CON
Register Function: Control register for the cascadable external interrupt pins

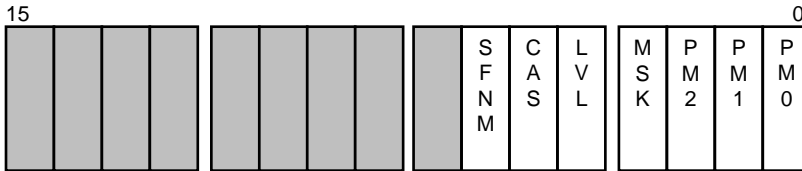

A1215-A0

Bit Mnemonic	Bit Name	Reset State	Function
SFNM	Special Fully Nested Mode	0	Set to enable special fully nested mode.
CAS	Cascade Mode	0	Set to enable cascade mode.
LVL	Level-trigger	0	Selects the interrupt triggering mode: 0 = edge triggering 1 = level triggering. The LVL bit must be set when external 8259As are cascaded into the Interrupt Control Unit.
MSK	Interrupt Mask	1	Clear to enable interrupts from this source.
PM2:0	Priority Level	111	Defines the priority level for this source.

NOTE: Reserved register bits are shown with gray shading. Reserved bits must be written to a logic zero to ensure compatibility with future Intel products.

Figure 8-6. Interrupt Control Register for Cascadable Interrupt Pins

8.4.2 Interrupt Request Register

The Interrupt Request register (Figure 8-7) has one bit for each interrupt source. When a source requests an interrupt, its Interrupt Request bit is set (without regard to whether the interrupt is masked). The Interrupt Request bit is cleared when the interrupt is acknowledged. An external interrupt pin must remain asserted until its interrupt is acknowledged. Otherwise, the Interrupt Request bit will be cleared, but the interrupt will not be serviced.

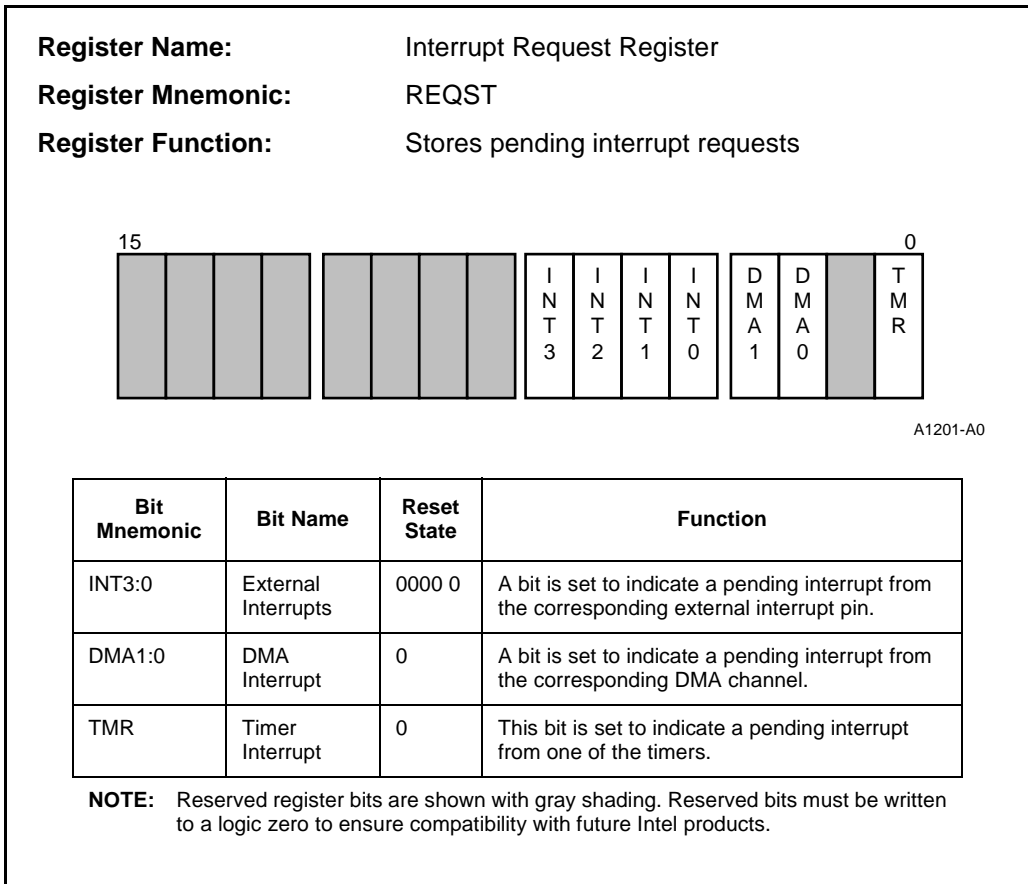
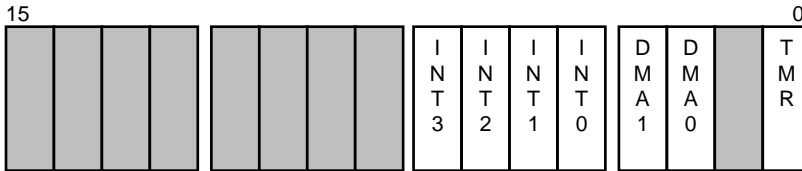

Figure 8-7. Interrupt Request Register

8.4.3 Interrupt Mask Register

The Interrupt Mask register (Figure 8-8) contains a mask bit for each interrupt source. This register allows you to mask (disable) individual interrupts. Set a mask bit to disable interrupts from the corresponding source. The mask bit is the same as the one in the Interrupt Control register. Modifying a bit in either register also modifies that same bit in the other register.

Register Name: Interrupt Mask Register
Register Mnemonic: IMASK
Register Function: Masks individual interrupt sources



A1202-A0

Bit Mnemonic	Bit Name	Reset State	Function
INT3:0	External Interrupt Mask	0000 0	Set a bit to mask (disable) interrupt requests from the corresponding external interrupt pin.
DMA1:0	DMA Interrupt Mask	0	Set to mask (disable) interrupt requests from the corresponding DMA channel.
TMR	Timer Interrupt Mask	0	Set to mask (disable) interrupt requests from the timers.

NOTE: Reserved register bits are shown with gray shading. Reserved bits must be written to a logic zero to ensure compatibility with future Intel products.

Figure 8-8. Interrupt Mask Register

8.4.4 Priority Mask Register

The Priority Mask register (Figure 8-9) contains a three-level field that holds a priority value. This register allows you to mask interrupts based on their priority levels. Write a priority value to the PM2:0 field to specify the lowest priority interrupt to be serviced. This disables (masks) any interrupt source whose priority is lower than the PM2:0 value. After reset, the Priority Mask register is set to the lowest priority (seven), which enables all interrupts of any priority.

Register Name: Priority Mask Register
Register Mnemonic: PRIMSK
Register Function: Masks lower-priority interrupt sources

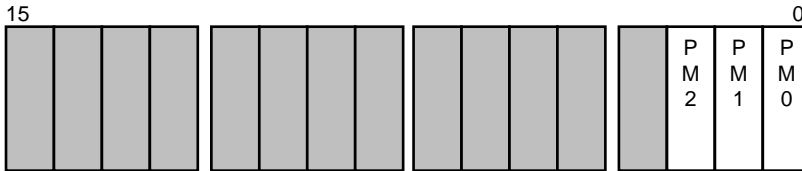

A1216-A0

Bit Mnemonic	Bit Name	Reset State	Function
PM2:0	Priority Mask	111	Defines a priority-based interrupt mask. Interrupts whose priority is lower than this value are masked.

NOTE: Reserved register bits are shown with gray shading. Reserved bits must be written to a logic zero to ensure compatibility with future Intel products.

Figure 8-9. Priority Mask Register

8.4.5 In-Service Register

The In-Service register has a bit for each interrupt source. The bits indicate which source's interrupt handlers are currently executing. The In-Service bit is set when an interrupt is acknowledged; the interrupt handler must clear it with an End-of-Interrupt (EOI) command. The Interrupt Control Unit uses the In-Service register to support interrupt nesting.

Register Name: In-Service Register
Register Mnemonic: INSERV
Register Function: Indicates which interrupt handlers are in process

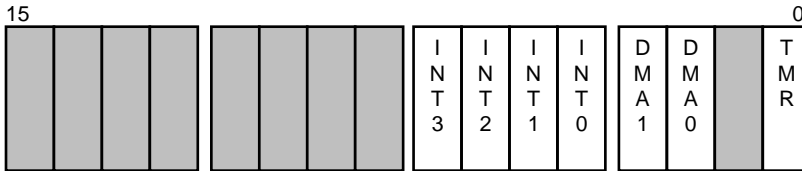

A1192-A0

Bit Mnemonic	Bit Name	Reset State	Function
INT3:0	External Interrupt In-Service	0000 0	A bit is set to indicate that the corresponding external interrupt is being serviced.
DMA1:0	DMA Interrupt In-Service	0	This bit is set to indicate that the corresponding DMA channel interrupt is being serviced.
TMR	Timer Interrupt In-Service	0	This bit is set to indicate that a timer interrupt is being serviced.

NOTE: Reserved register bits are shown with gray shading. Reserved bits must be written to a logic zero to ensure compatibility with future Intel products.

Figure 8-10. In-Service Register

8.4.6 Poll and Poll Status Registers

The Poll and Poll Status registers allow you to poll the Interrupt Control Unit and service interrupts through software. You can read these registers to determine whether an interrupt is pending and, if so, the interrupt type. The registers contain identical information, but reading them produces different results.

Reading the Poll register (Figure 8-11) acknowledges the pending interrupt, just as if the CPU had started the interrupt vectoring sequence. The Interrupt Control Unit updates the Interrupt Request, In-Service, Poll, and Poll Status registers, as it does in the normal interrupt acknowledge sequence. However, the processor does not run an interrupt acknowledge sequence or fetch the vector from the vector table. Instead, software must read the interrupt type and execute the proper routine to service the pending interrupt.

Reading the Poll Status register (Figure 8-12) will merely transmit the status of the polling bits without modifying any of the other Interrupt Controller registers.

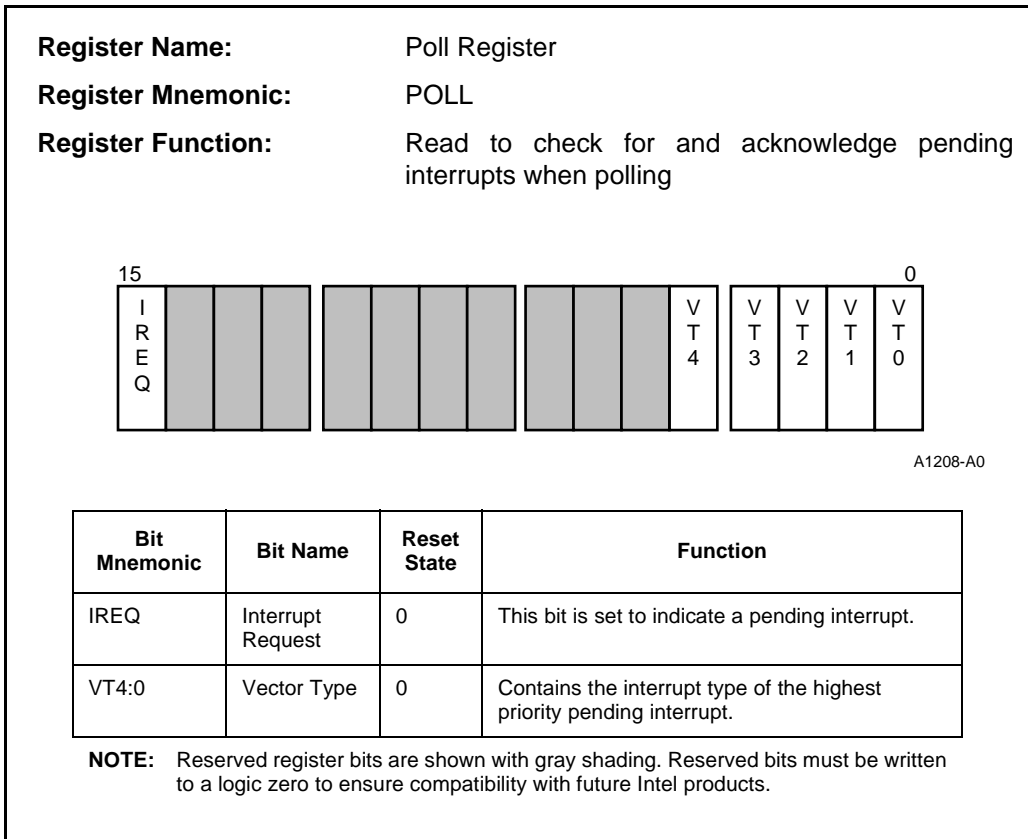

Figure 8-11. Poll Register

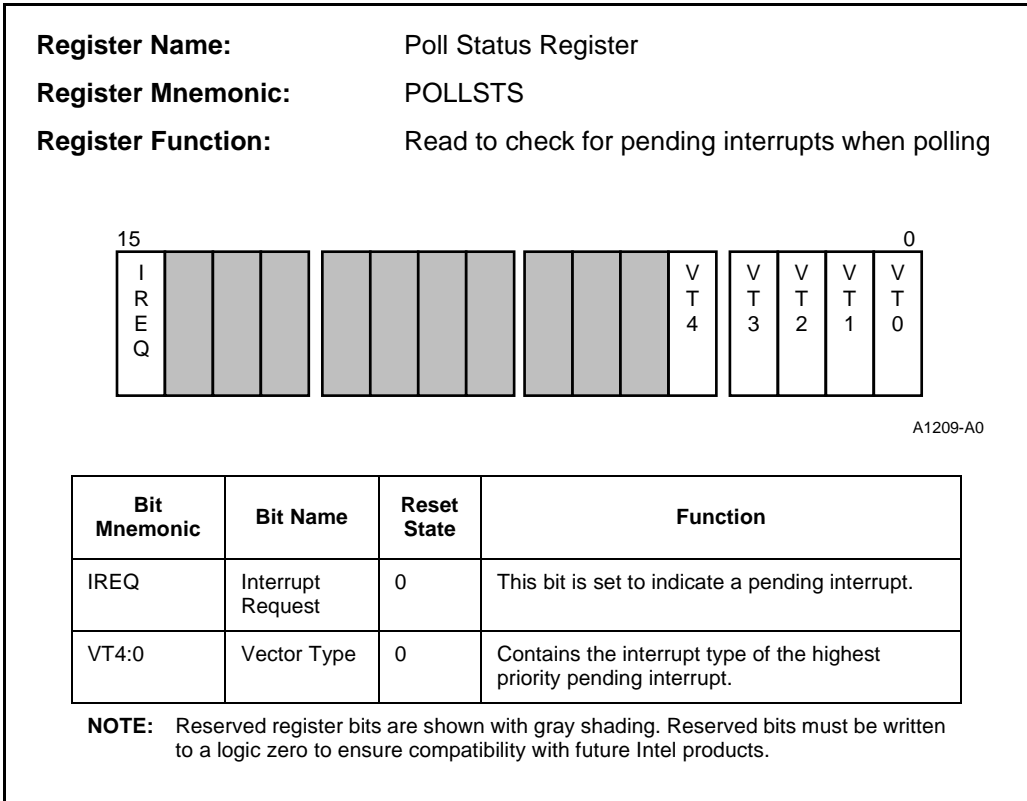

Figure 8-12. Poll Status Register

8.4.7 End-of-Interrupt (EOI) Register

The End-of-Interrupt register (Figure 8-13) issues an End-of-Interrupt (EOI) command to the Interrupt Control Unit, which clears the In-Service bit for the associated interrupt. An interrupt handler typically ends with an EOI command. There are two types of EOI commands: nonspecific and specific. A nonspecific EOI simply clears the In-Service bit of the highest priority interrupt. To issue a nonspecific EOI command, set the NSPEC bit. (Write 8000H to the EOI register.)

A specific EOI clears a particular In-Service bit. To issue a specific EOI command, clear the NSPEC bit and write the VT4:0 bits with the interrupt type of the interrupt whose In-Service bit you wish to clear. For example, to clear the In-Service bit for INT2, write 000EH to the EOI register. The timer interrupts share an In-Service bit. To clear the In-Service bit for any timer interrupt with a specific EOI, write 0008H (interrupt type 8) to the EOI register.

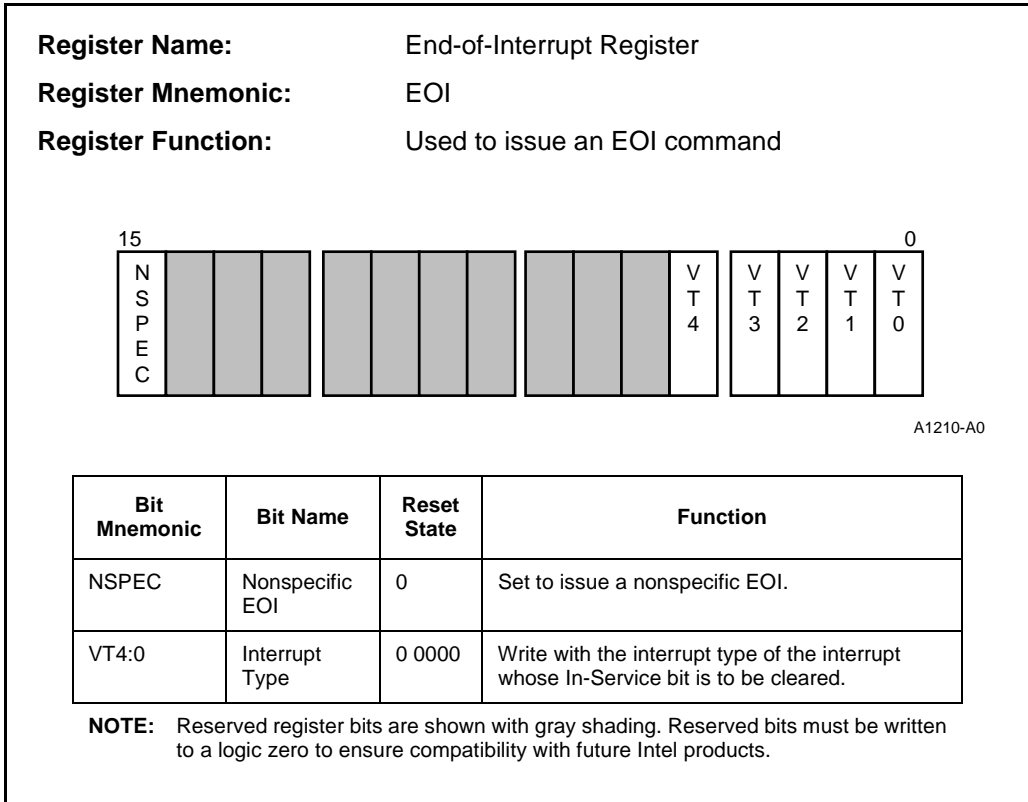
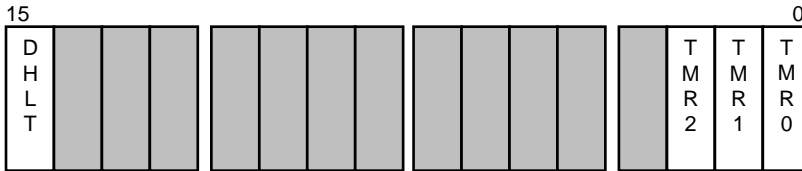

Figure 8-13. End-of-Interrupt Register

8.4.8 Interrupt Status Register

The Interrupt Status register (Figure 8-14) contains the DMA Halt bit and one bit for each timer interrupt. The CPU sets the DMA Halt bit to suspend DMA transfers while an NMI is processed. Software can also read and write this bit. See “Suspension of DMA Transfers” on page 10-20 for details. A timer bit is set to indicate a pending interrupt and is cleared when the interrupt request is acknowledged. Any number of bits can be set at any one time.

Register Name: Interrupt Status Register
Register Mnemonic: INTSTS
Register Function: Indicates pending shared-source interrupts and DMA suspension



A1193-A0

Bit Mnemonic	Bit Name	Reset State	Function
DHLT	DMA Halt	0	This bit is set to suspend DMA activity.
TMR2:0	Timer Interrupt Pending	000	A bit is set to indicate a pending interrupt from the corresponding timer.

NOTE: Reserved register bits are shown with gray shading. Reserved bits must be written to a logic zero to ensure compatibility with future Intel products.

Figure 8-14. Interrupt Status Register

NOTE

Do not write to the DHLT bit while Timer/Counter Unit interrupts are enabled. A conflict with the internal use of the register may cause incorrect processing of timer interrupts.

The DHLT bit does not function when the interrupt controller is in slave mode.

8.5 SLAVE MODE

Although Master mode is the most common, Slave mode is useful in larger system designs. In Slave mode, an external 8259A module controls the interrupt input to the CPU and acts as the master interrupt controller. The Interrupt Control Unit processes only the internal interrupt requests and acts as an interrupt input to the external 8259A. In simplest terms, the Interrupt Control Unit behaves like a cascaded 8259A to the master 8259A. (See Figures 8-15 and 8-16.)

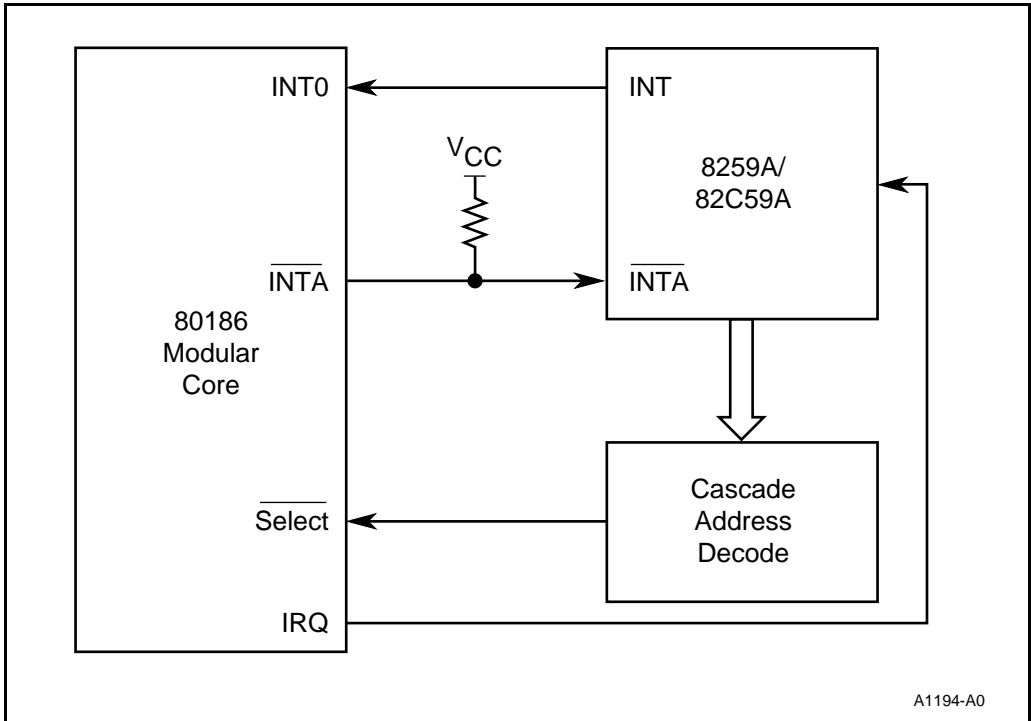

Figure 8-15. Interrupt Control Unit in Slave Mode

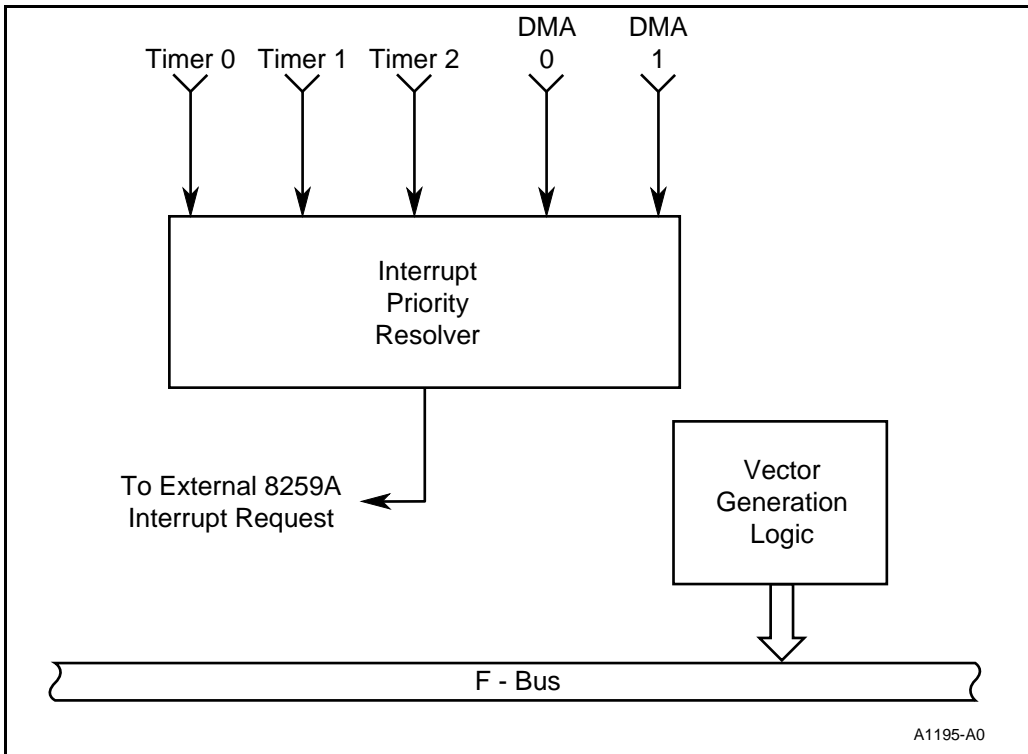

Figure 8-16. Interrupt Sources in Slave Mode

8.5.1 Slave Mode Programming

Some registers differ between Slave mode and Master mode. Slave mode adds the Interrupt Vector Register; it does not support the Poll, Poll Status Registers, INT3 and INT2 Control registers; and it replaces the Timer, INT1 and INT0 Control registers with individual Timer 0, Timer 1, and Timer 2 Control registers. The remaining registers retain the same functions as in Master mode; however, some bit positions change to accommodate the addition of the individual timer interrupts and the deletion of the external interrupts. Table 8-4 compares the Master and Slave mode registers and lists their PCB offset addresses.

8.5.1.1 Interrupt Vector Register

The Interrupt Vector Register is used only in Slave mode. In Master mode, the interrupt vector types are fixed; in Slave mode they are programmable. The Interrupt Vector Register is used to specify the five most-significant bits of the interrupt vector type. The three least-significant bits are fixed (Table 8-5).

Table 8-4. Interrupt Control Unit Register Comparison

Master Mode Register Name	Slave Mode Register Name	PCB Offset Address
INT3 Control	(not used)	3EH
INT2 Control	(not used)	3CH
INT1 Control	Timer 2 Control	3AH
INT0 Control	Timer 1 Control	38H
DMA1 Control	DMA1 Control	36H
DMA0 Control	DMA0 Control	34H
Timer Control	Timer 0 Control	32H
Interrupt Status	Interrupt Status	30H
Interrupt Request	Interrupt Request	2EH
In-Service	In-Service	2CH
Priority Mask	Priority Mask	2AH
Interrupt Mask	Interrupt Mask	28H
Poll Status	(not used)	26H
Poll	(not used)	24H
EOI	EOI	22H
(not used)	Interrupt Vector	20H

Table 8-5. Slave Mode Fixed Interrupt Type Bits

Interrupt Source	Type Bits		
	2	1	0
Timer 0	0	0	0
(reserved)	0	0	1
DMA 0	0	1	0
DMA 1	0	1	1
Timer 1	1	0	0
Timer 2	1	0	1
(reserved)	1	1	0
(reserved)	1	1	1

Register Name: Interrupt Vector Register (Slave Mode only)
Register Mnemonic: INTVEC
Register Function: Specifies the five most-significant bit of the interrupt vector types for the internal interrupt sources

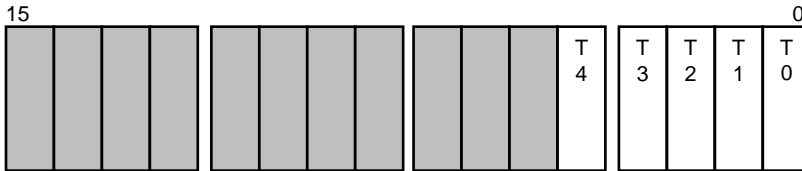

A1196-A0

Bit Mnemonic	Bit Name	Reset State	Function
T4:0	Interrupt Vector Type Field	00000	Specifies the five most-significant bits of the interrupt vector types for the internal interrupt sources. The three least-significant bits are fixed (see Table 8-5).

NOTE: Reserved register bits are shown with gray shading. Reserved bits must be written to a logic zero to ensure compatibility with future Intel products.

Figure 8-17. Interrupt Vector Register (Slave Mode Only)

8.5.1.2 End-Of-Interrupt Register

The End-of-Interrupt (EOI) register has the same function in Slave mode as in Master mode. However, non-specific EOI commands are not supported, so the NSPEC bit is omitted from the register. Only **specific** EOI commands can be issued. To clear an In-Service bit in Slave mode, write the three least-significant bits of the interrupt type (from Table 8-5) to the VT2:0 bits.

Register Name: End-of-Interrupt Register (in Slave Mode)
Register Mnemonic: EOI
Register Function: Used to issue the EOI command

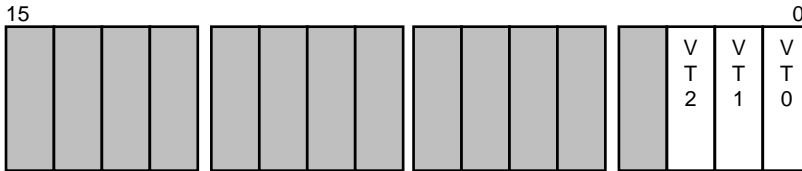

A1197-A0

Bit Mnemonic	Bit Name	Reset State	Function
VT2:0	Interrupt Type	0	Write the three LSBs of the interrupt type (see Table 8-5) to these bits to issue an EOI command in slave mode.

NOTE: Reserved register bits are shown with gray shading. Reserved bits must be written to a logic zero to ensure compatibility with future Intel products.

Figure 8-18. End-of-Interrupt Register in Slave Mode

8.5.1.3 Other Registers

The Priority Mask register is identical in Slave mode and Master mode. The Interrupt Request, Interrupt Mask, and In-Service registers retain the same function, but individual bits differ to accommodate the addition of the individual timer interrupts and the deletion of the external interrupts. Figure 8-19 shows the bit positions for Slave mode.

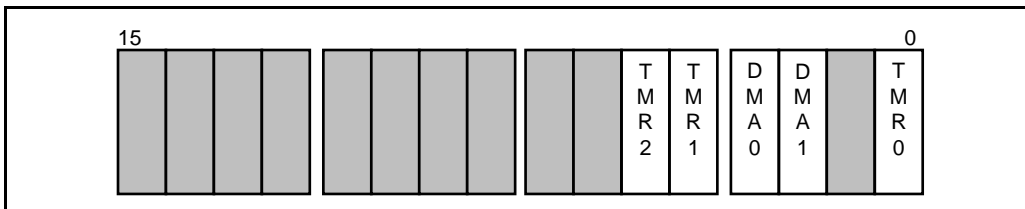

Figure 8-19. Request, Mask, and In-Service Registers

8.5.2 Interrupt Vectoring in Slave Mode

In Slave mode, the external 8259A module acts as the master interrupt controller. Therefore, interrupt acknowledge cycles are required for every interrupt, including those from integrated peripherals. During the first interrupt acknowledge cycle, the external 8259A determines which slave interrupt controller has the highest priority interrupt request. It then drives that slave's address onto its $\overline{\text{CAS}}2:0$ pins (Figure 8-20). External logic must decode the correct slave address from the $\overline{\text{CAS}}2:0$ pins to drive the $\overline{\text{SELECT}}$ pin.

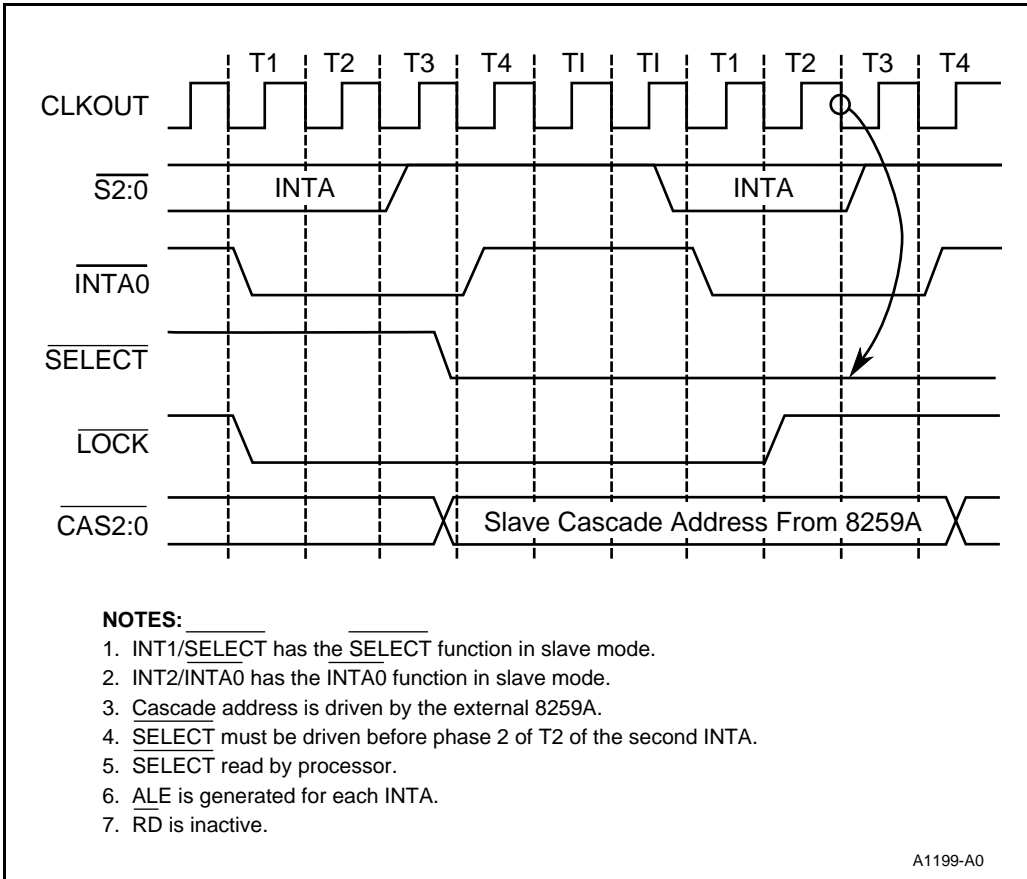

Figure 8-20. Interrupt Vectoring in Slave Mode

The $\overline{\text{SELECT}}$ pin is the slave-select input to the Interrupt Control Unit. During the second interrupt acknowledge cycle, the highest-priority slave interrupt controller transfers the interrupt type of its highest priority interrupt to the CPU. If the Interrupt Control Unit is the highest-priority slave, it passes the interrupt type to the CPU internally; however, the interrupt acknowledge cycle still must occur for the benefit of the external 8259A module.

External interrupt acknowledge cycles must be run for every maskable interrupt. Therefore, the interrupt response time for every interrupt will be 55 clocks, as shown in Figure 8-21.

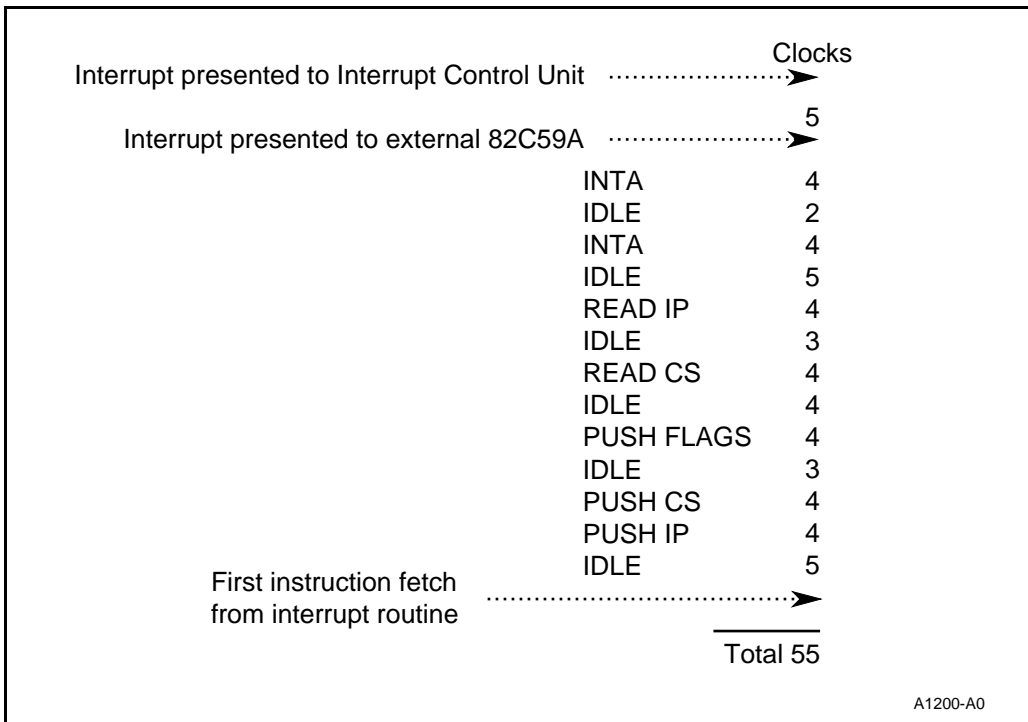

Figure 8-21. Interrupt Response Time in Slave Mode

8.5.3 Initializing the Interrupt Control Unit for Master Mode

Follow these steps to initialize the Interrupt Control Unit for Master mode.

1. Determine which interrupt sources you want to use.
2. Determine whether to use the default priority scheme or devise your own.
3. Program the Interrupt Control register for each interrupt source.
 - For external interrupt pins, select edge or level triggering.
 - For INT0 or INT1, enable cascade mode, special fully nested mode, or both, if you wish to use them.
 - If you are using a custom priority scheme, program the priority level for each interrupt source.
4. Program the Priority Mask with a priority mask level, if you wish to mask interrupts based on priority. (The default is level seven, which enables all interrupt levels.)

5. Set the mask bit in the Interrupt Mask register for any interrupts that you wish to disable.

Example 8-1 shows sample code to initialize the Interrupt Control Unit.

```
$mod186
name          example_80C186_ICU_initialization
;
;This routine configures the interrupt controller to provide two cascaded
;interrupt inputs (through an external 8259A connected to INT0 and INTA0#)
;and two direct interrupt inputs connected to INT1 and INT3. The default
;priorities are used.
;
;The example assumes that the register addresses have been properly defined.
;
code          segment
              assume cs:code
set_int_      proc near
              push dx
              push ax
              mov  ax,0110111B                ;cascade mode, priority seven
              mov  dx,I0CON                    ;INT0 control register
              out  dx,ax
              mov  ax,01001101B               ;unmask INT1 and INT3
              mov  dx,IMASK
              out  dx,ax
              pop  ax
              pop  dx
              ret
set_int_      endp
code          ends
end
```

Example 8-1. Initializing the Interrupt Control Unit for Master Mode





9

Timer/Counter Unit



CHAPTER 9

TIMER/COUNTER UNIT

The Timer/Counter Unit can be used in many applications. Some of these applications include a real-time clock, a square-wave generator and a digital one-shot. All of these can be implemented in a system design. A real-time clock can be used to update time-dependent memory variables. A square-wave generator can be used to provide a system clock tick for peripheral devices. (See “Timer/Counter Unit Application Examples” on page 9-17 for code examples that configure the Timer/Counter Unit for these applications.)

9.1 FUNCTIONAL OVERVIEW

The Timer/Counter Unit is composed of three independent 16-bit timers (see Figure 9-1). The operation of these timers is independent of the CPU. The internal Timer/Counter Unit can be modeled as a single counter element, time-multiplexed to three register banks. The register banks are dual-ported between the counter element and the CPU. During a given bus cycle, the counter element and CPU can both access the register banks; these accesses are synchronized.

The Timer/Counter Unit is serviced over four clock periods, one timer during each clock, with an idle clock at the end (see Figure 9-2). No connection exists between the counter element’s sequencing through timer register banks and the Bus Interface Unit’s sequencing through T-states. Timer operation and bus interface operation are asynchronous. This time-multiplexed scheme results in a delay of $2\frac{1}{2}$ to $6\frac{1}{2}$ CLKOUT periods from timer input to timer output.

Each timer keeps its own running count and has a user-defined maximum count value. Timers 0 and 1 can use one maximum count value (single maximum count mode) or two alternating maximum count values (dual maximum count mode). Timer 2 can use only one maximum count value. The control register for each timer determines the counting mode to be used. When a timer is serviced, its present count value is incremented and compared to the maximum count for that timer. If these two values match, the count value resets to zero. The timers can be configured either to stop after a single cycle or to run continuously.

Timers 0 and 1 are functionally identical. Figure 9-3 illustrates their operation. Each has a latched, synchronized input pin and a single output pin. Each timer can be clocked internally or externally. Internally, the timer can either increment at $\frac{1}{4}$ CLKOUT frequency or be prescaled by Timer 2. A timer that is prescaled by Timer 2 increments when Timer 2 reaches its maximum count value.

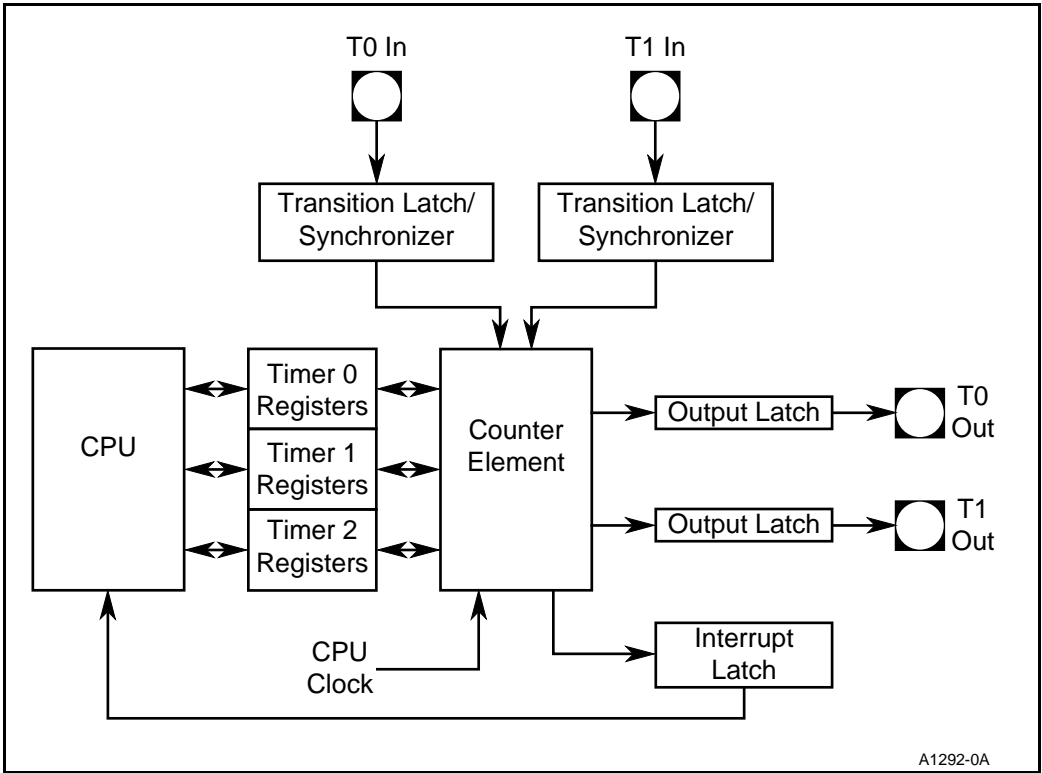

Figure 9-1. Timer/Counter Unit Block Diagram

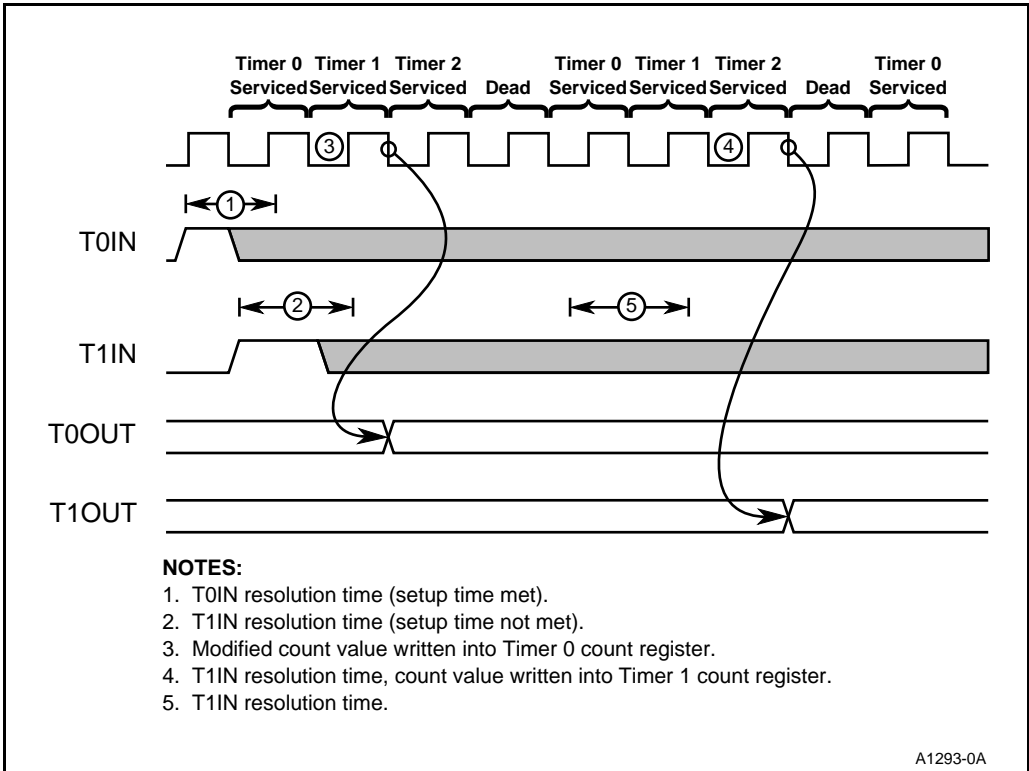
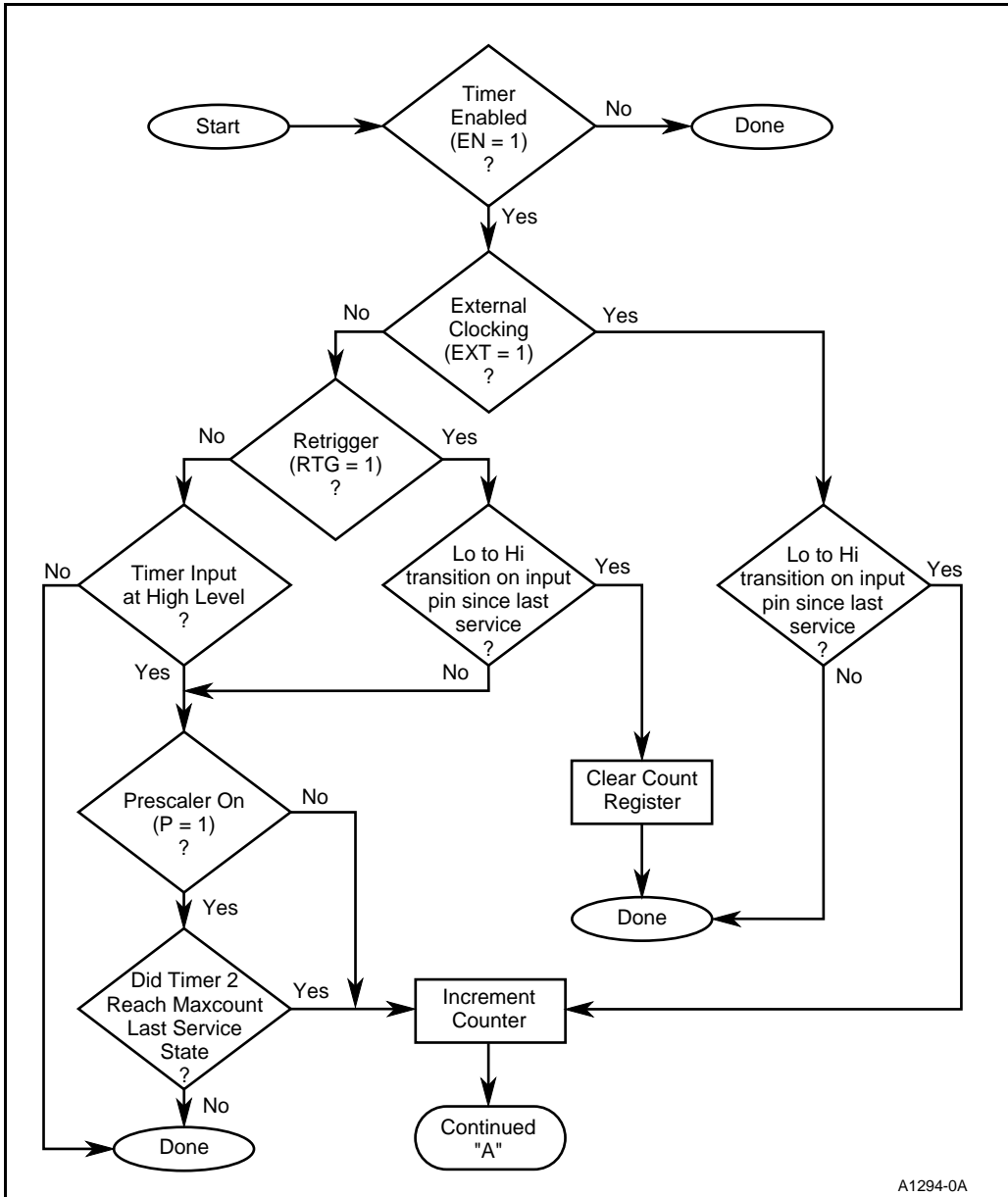
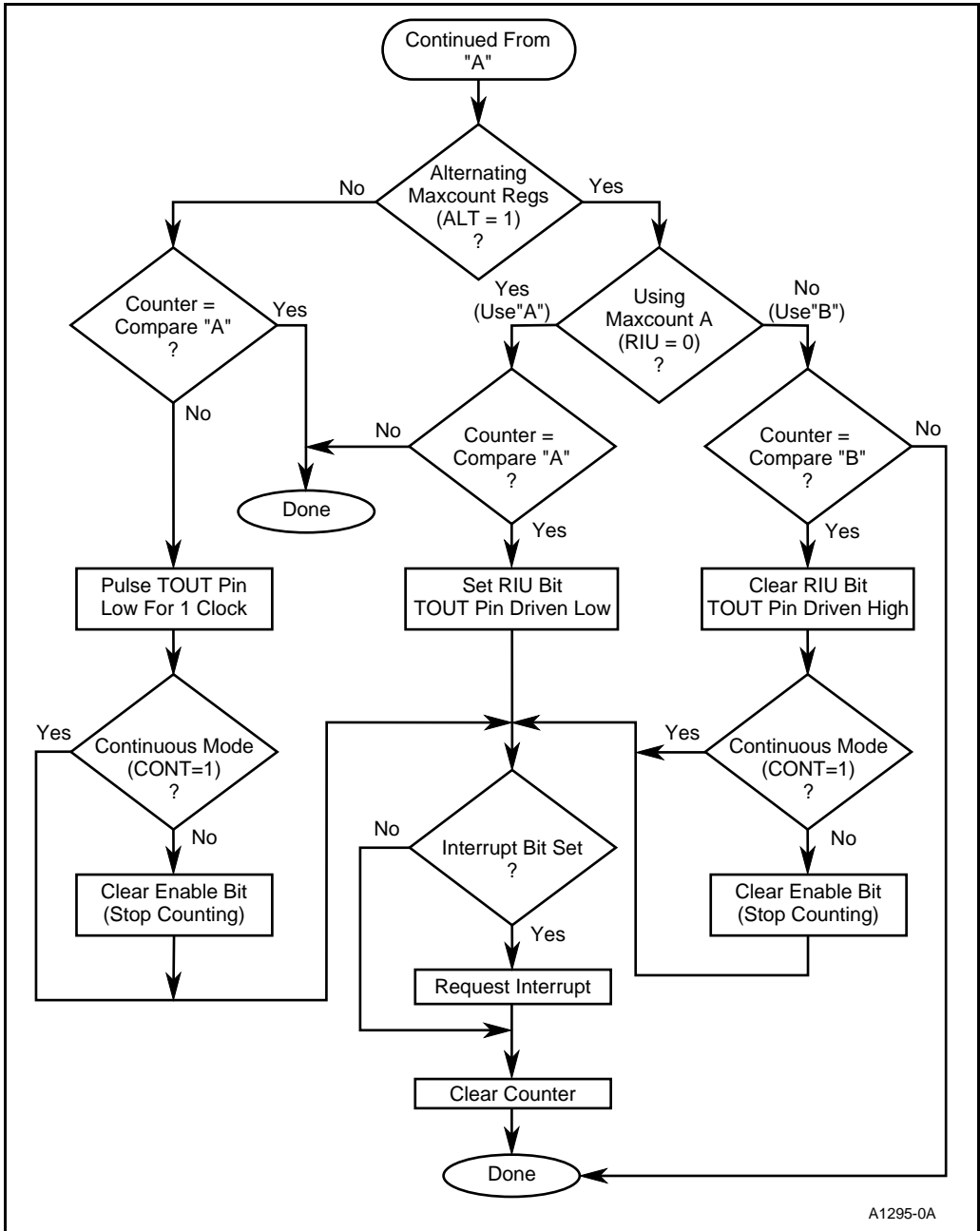

Figure 9-2. Counter Element Multiplexing and Timer Input Synchronization



A1294-0A

Figure 9-3. Timers 0 and 1 Flow Chart



A1295-0A

Figure 9-3. Timers 0 and 1 Flow Chart (Continued)

When configured for internal clocking, the Timer/Counter Unit uses the input pins either to enable timer counting or to retrigger the associated timer. Externally, a timer increments on low-to-high transitions on its input pin (up to $\frac{1}{4}$ CLKOUT frequency).

Timers 0 and 1 each have a single output pin. Timer output can be either a single pulse, indicating the end of a timing cycle, or a variable duty cycle wave. These two output options correspond to single maximum count mode and dual maximum count mode, respectively (Figure 9-4). Interrupts can be generated at the end of every timing cycle.

Timer 2 has no input or output pins and can be operated only in single maximum count mode (Figure 9-4). It can be used as a free-running clock and as a prescaler to Timers 0 and 1. Timer 2 can be clocked only internally, at $\frac{1}{4}$ CLKOUT frequency. Timer 2 can also generate interrupts at the end of every timing cycle.

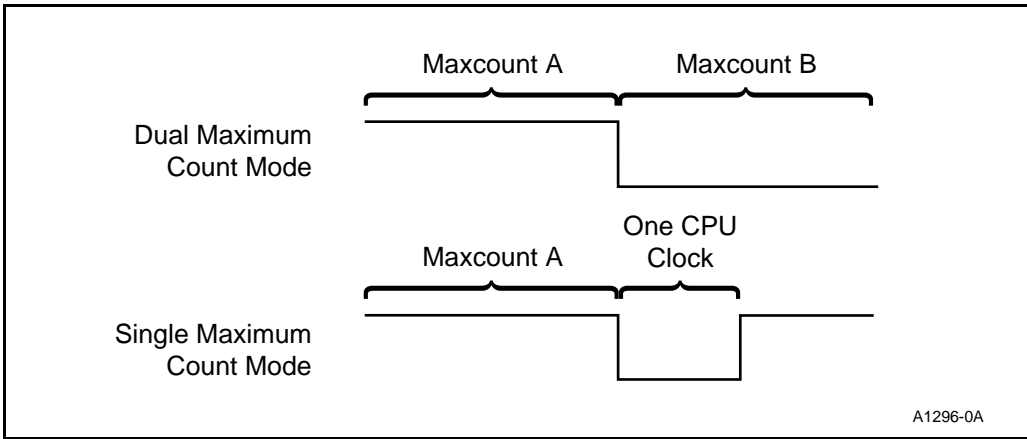
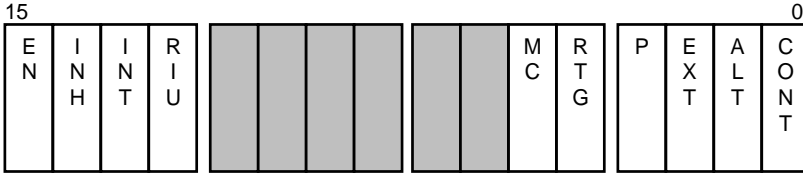

Figure 9-4. Timer/Counter Unit Output Modes

9.2 PROGRAMMING THE TIMER/COUNTER UNIT

Each timer has three registers: a Timer Control register (Figure 9-5 and Figure 9-6), a Timer Count register (Figure 9-7) and a Timer Maxcount Compare register (Figure 9-8). Timers 0 and 1 also have access to an additional Maxcount Compare register. The Timer Control register controls timer operation. The Timer Count register holds the current timer count value, and the Maxcount Compare register holds the maximum timer count value.

Register Name: Timer 0 and 1 Control Registers
Register Mnemonic: T0CON, T1CON
Register Function: Defines Timer 0 and 1 operation.



A1297-0A

Bit Mnemonic	Bit Name	Reset State	Function
EN	Enable	0	Set to enable the timer. This bit can be written only when the INH bit is set.
INH	Inhibit	X	Set to enable writes to the EN bit. Clear to ignore writes to the EN bit. The INH bit is not stored; it always reads as zero.
INT	Interrupt	X	Set to generate an interrupt request when the Count register equals a Maximum Count register. Clear to disable interrupt requests.
RIU	Register In Use	X	Indicates which compare register is in use. When set, the current compare register is Maxcount Compare B; when clear, it is Maxcount Compare A.
MC	Maximum Count	X	This bit is set when the counter reaches a maximum count. The MC bit must be cleared by writing to the Timer Control register. This is not done automatically. If MC is clear, the counter has not reached a maximum count.

NOTE: Reserved register bits are shown with gray shading. Reserved bits must be written to a logic zero to ensure compatibility with future Intel products.

Figure 9-5. Timer 0 and Timer 1 Control Registers

Register Name: Timer 0 and 1 Control Registers

Register Mnemonic: T0CON, T1CON

Register Function: Defines Timer 0 and 1 operation.

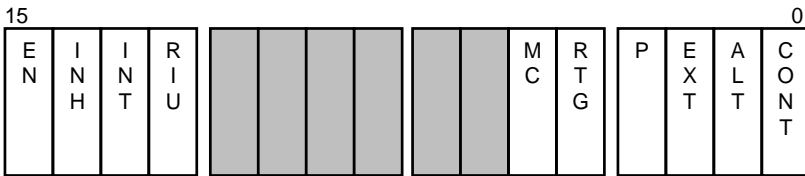

A1297-0A

Bit Mnemonic	Bit Name	Reset State	Function
RTG	Retrigger	X	This bit specifies the action caused by a low-to-high transition on the TMR INx input. Set RTG to reset the count; clear RTG to enable counting. This bit is ignored with external clocking (EXT=1).
P	Prescaler	X	Set to increment the timer when Timer 2 reaches its maximum count. Clear to increment the timer at ¼ CLKOUT. This bit is ignored with external clocking (EXT=1).
EXT	External Clock	X	Set to use external clock; clear to use internal clock. The RTG and P bits are ignored with external clocking (EXT set).
ALT	Alternate Compare Register	X	This bit controls whether the timer runs in single or dual maximum count mode (see Figure 9-4 on page 9-6). Set to specify dual maximum count mode; clear to specify single maximum count mode.
CONT	Continuous Mode	X	Set to cause the timer to run continuously. Clear to disable the counter (clear the EN bit) after each counting sequence.

NOTE: Reserved register bits are shown with gray shading. Reserved bits must be written to a logic zero to ensure compatibility with future Intel products.

Figure 9-5. Timer 0 and Timer 1 Control Registers (Continued)

Register Name: Timer 2 Control Register
Register Mnemonic: T2CON
Register Function: Defines Timer 2 operation.



A1298-UA

Bit Mnemonic	Bit Name	Reset State	Function
EN	Enable	0	Set to enable the timer. This bit can be written only when the $\overline{\text{INH}}$ bit is set.
INH	Inhibit	X	Set to enable writes to the EN bit. Clear to ignore writes to the EN bit. The $\overline{\text{INH}}$ bit is not stored; it always reads as zero.
INT	Interrupt	X	Set to generate an interrupt request when the Count register equals a Maximum Count register. Clear to disable interrupt requests.
MC	Maximum Count	X	This bit is set when the counter reaches a maximum count. The MC bit must be cleared by writing to the Timer Control register. This is not done automatically. If MC is clear, the counter has not reached a maximum count.
CONT	Continuous Mode	X	Set to cause the timer to run continuously. Clear to disable the counter (clear the EN bit) after each counting sequence.

NOTE: Reserved register bits are shown with gray shading. Reserved bits must be written to a logic zero to ensure compatibility with future Intel products.

Figure 9-6. Timer 2 Control Register

Register Name: Timer Count Register
Register Mnemonic: T0CNT, T1CNT, T2CNT
Register Function: Contains the current timer count.

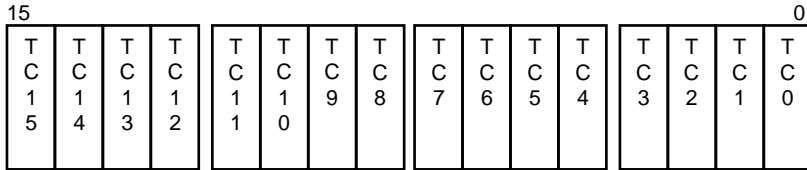

A1299-0A

Bit Mnemonic	Bit Name	Reset State	Function
TC15:0	Timer Count Value	XXXXH	Contains the current count of the associated timer.

Figure 9-7. Timer Count Registers

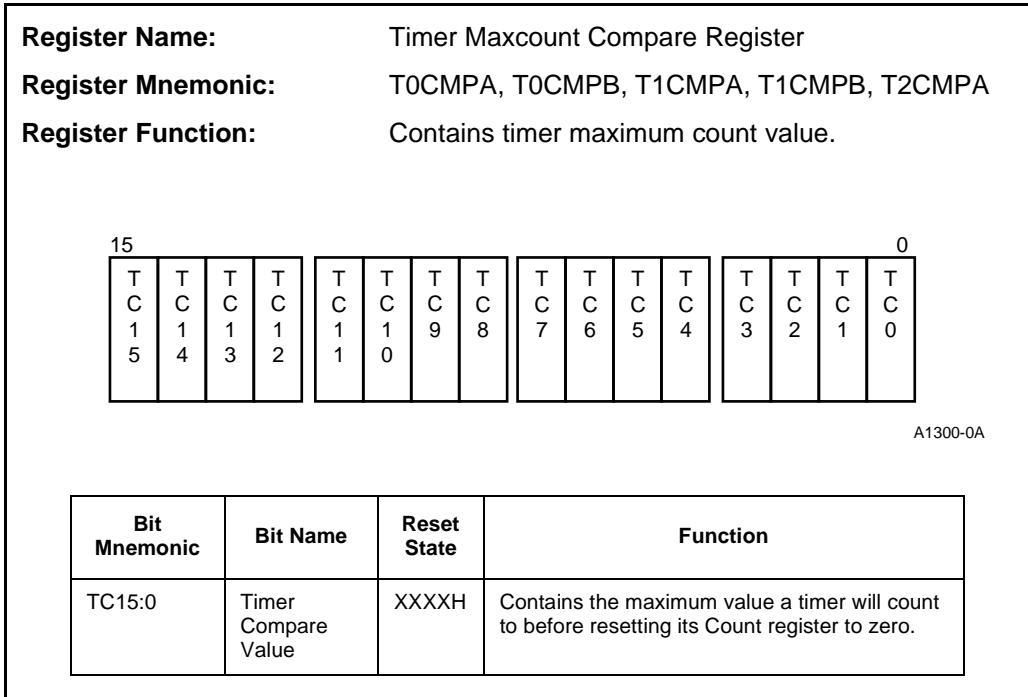

Figure 9-8. Timer Maxcount Compare Registers

9.2.1 Initialization Sequence

When initializing the Timer/Counter Unit, the following sequence is suggested:

1. If timer interrupts will be used, program interrupt vectors into the Interrupt Vector Table.
2. **Clear the Timer Count register.** This must be done before the timer is enabled because the count register is undefined at reset. Clearing the count register ensures that counting begins at zero.
3. Write the desired maximum count value to the Timer Maxcount Compare register. For dual maximum count mode, write a value to both Maxcount Compare A and B.
4. Program the Timer Control register to enable the timer. When using Timer 2 to prescale another timer, enable Timer 2 last. If Timer 2 is enabled first, it will be at an unknown point in its timing cycle when the timer to be prescaled is enabled. This results in an unpredictable duration of the first timing cycle for the prescaled timer.

9.2.2 Clock Sources

The 16-bit Timer Count register increments once for each timer event. A timer event can be a low-to-high transition on a timer input pin (Timers 0 and 1), a pulse generated every fourth CPU clock (all timers) or a timeout of Timer 2 (Timers 0 and 1). Up to 65536 (2^{16}) events can be counted.

Timers 0 and 1 can be programmed to count low-to-high transitions on their input pins as timer events by setting the External (EXT) bit in their control registers. Transitions on the external pin are synchronized to the CPU clock before being presented to the timer circuitry. The timer counts **transitions** on this pin. The input signal must go low, then high, to cause the timer to increment. The maximum count-rate for the timers is $\frac{1}{4}$ the CPU clock rate (measured at CLKOUT) because the timers are serviced only once every four clocks.

All timers can use transitions of the CPU clock as timer events. For internal clocking, the timer increments every fourth CPU clock due to the counter element's time-multiplexed servicing scheme. Timer 2 can use only the internal clock as a timer event.

Timers 0 and 1 can also use Timer 2 reaching its maximum count as a timer event. In this configuration, Timer 0 or Timer 1 increments each time Timer 2 reaches its maximum count. See Table 9-1 for a summary of clock sources for Timers 0 and 1. Timer 2 must be initialized and running in order to increment values in other timer/counters.

Table 9-1. Timer 0 and 1 Clock Sources

EXT	P	Clock Source
0	0	Timer clocked internally at $\frac{1}{4}$ CLKOUT frequency.
0	1	Timer clocked internally, prescaled by Timer 2.
1	X	Timer clocked externally at up to $\frac{1}{4}$ CLKOUT frequency.

9.2.3 Counting Modes

All timers have a Timer Count register and a Maxcount Compare A register. Timers 0 and 1 also have access to a second Maxcount Compare B register. Whenever the contents of the Timer Count register equal the contents of the Maxcount Compare register, the count register resets to zero. The maximum count value will never be stored in the count register. This is because the counter element increments, compares and resets a timer in one clock cycle. Therefore, the maximum value is never written back to the count register. The Maxcount Compare register can be written at any time during timer operation.

The timer counting from its initial count (usually zero) to its maximum count (either Maxcount Compare A or B) and resetting to zero defines one timing cycle. A Maxcount Compare value of 0 implies a maximum count of 65536, a Maxcount Compare value of 1 implies a maximum count of 1, etc.

Only equivalence between the Timer Count and Maxcount Compare registers is checked. The count does not reset to zero if its value is greater than the maximum count. If the count value exceeds the Maxcount Compare value, the timer counts to 0FFFFH, increments to zero, then counts to the value in the Maxcount Compare register. Upon reaching a maximum count value, the Maximum Count (MC) bit in the Timer Control register sets. **The MC bit must be cleared by writing to the Timer Control register. This is not done automatically.**

The Timer/Counter Unit can be configured to execute different counting sequences. The timers can operate in single maximum count mode (all timers) or dual maximum count mode (Timers 0 and 1 only). They can also be programmed to run continuously in either of these modes. The Alternate (ALT) bit in the Timer Control register determines the counting modes used by Timers 0 and 1.

All timers can use single maximum count mode, where only Maxcount Compare A is used. The timer will count to the value contained in Maxcount Compare A and reset to zero. Timer 2 can operate only in this mode.

Timers 0 and 1 can also use dual maximum count mode. In this mode, Maxcount Compare A and Maxcount Compare B are both used. The timer counts to the value contained in Maxcount Compare A, resets to zero, counts to the value contained in Maxcount Compare B, and resets to zero again. The Register In Use (RIU) bit in the Timer Control register indicates which Maxcount Compare register is currently in use.

The timers can be programmed to run continuously in single maximum count and dual maximum count modes. The Continuous (CONT) bit in the Timer Control register determines whether a timer is disabled after a single counting sequence.

9.2.3.1 Retriggerring

The timer input pins affect timer counting in three ways (see Table 9-2). The programming of the External (EXT) and Retriggerring (RTG) bits in the Timer Control register determines how the input signals are used. When the timers are clocked internally, the RTG bit determines whether the input pin enables timer counting or retriggers the current timing cycle.

When the EXT and RTG bits are clear, the timer counts internal timer events. In this mode, the input is level-sensitive, not edge-sensitive. A low-to-high transition on the timer input is not required for operation. The input pin acts as an external enable. If the input is high, the timer will count through its sequence, provided the timer remains enabled.

Table 9-2. Timer Retriggering

EXT	RTG	Timer Operation
0	0	Timer counts internal events, if input pin remains high.
0	1	Timer counts internal events; count resets to zero on every low-to-high transition on the input pin.
1	X	Timer input acts as clock source.

When the EXT bit is clear and the RTG bit is set, every low-to-high transition on the timer input pin causes the Count register to reset to zero. After the timer is enabled, counting begins only after the first low-to-high transition on the input pin. If another low-to-high transition occurs before the end of the timer cycle, the timer count resets to zero and the timer cycle begins again. In dual maximum count mode, the Register In Use (RIU) bit does not clear when a low-to-high transition occurs. For example, if the timer retriggers while Maxcount Compare B is in use, the timer resets to zero and counts to maximum count B before the RIU bit clears. **In dual maximum count mode, the timer retriggering extends the use of the current Maxcount Compare register.**

9.2.4 Pulsed and Variable Duty Cycle Output

Timers 0 and 1 each have an output pin that can perform two functions. First, the output can be a single pulse, indicating the end of a timing cycle (single maximum count mode). Second, the output can be a level, indicating the Maxcount Compare register currently in use (dual maximum count mode). The output occurs one clock after the counter element services the timer when the maximum count is reached (see Figure 9-9).

With external clocking, the time between a transition on a timer input and the corresponding transition of the timer output varies from $2\frac{1}{2}$ to $6\frac{1}{2}$ clocks. This delay occurs due to the time-multiplexed servicing scheme of the Timer/Counter Unit. The exact timing depends on when the input occurs relative to the counter element’s servicing of the timer. Figure 9-2 on page 9-3 shows the two extremes in timer output delay. Timer 0 demonstrates the best possible case, where the input occurs immediately before the timer is serviced. Timer 1 demonstrates the worst possible case, where the input is latched, but the setup time is not met and the input is not recognized until the counter element services the timer again.

In single maximum count mode, the timer output pin goes low for one CPU clock period (see Figure 9-4 on page 9-6). This occurs when the count value equals the Maxcount Compare A value. If programmed to run continuously, the timer generates periodic pulses.

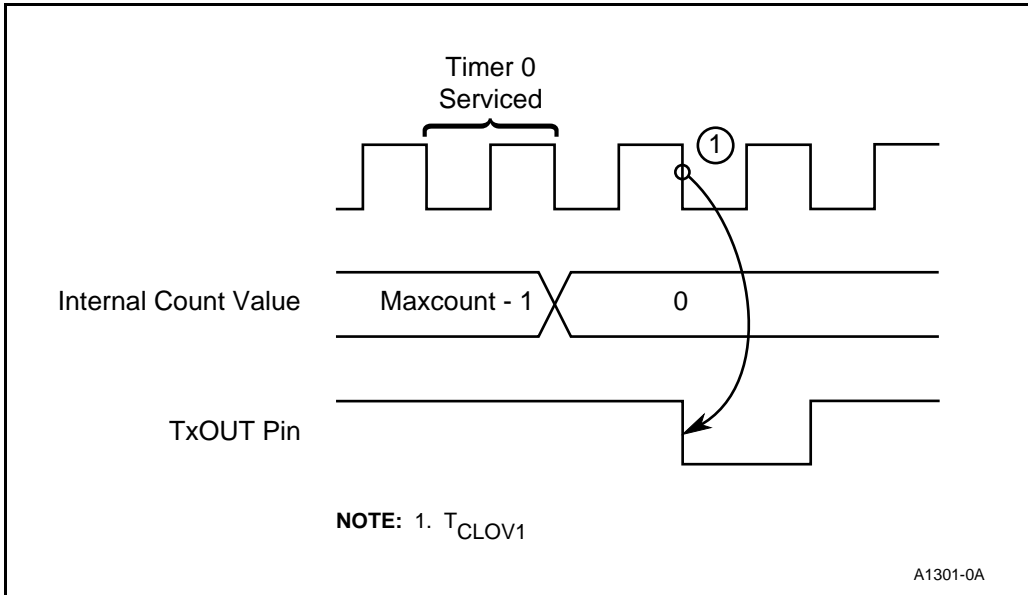

Figure 9-9. TxOUT Signal Timing

In dual maximum count mode, the timer output pin indicates which Maxcount Compare register is currently in use. A low output indicates Maxcount Compare B, and a high output indicates Maxcount Compare A (see Figure 9-4 on page 9-6). If programmed to run continuously, a repetitive waveform can be generated. For example, if Maxcount Compare A contains 10, Maxcount Compare B contains 20, and CLKOUT is 12.5 MHz, the timer generates a 33 percent duty cycle waveform at 104 KHz. The output pin always goes high at the end of the counting sequence (even if the timer is not programmed to run continuously).

9.2.5 Enabling/Disabling Counters

Each timer has an Enable (EN) bit in its Control register to allow or prevent timer counting. The Inhibit (\overline{INH}) bit controls write accesses to the EN bit. Timers 0 and 1 can be programmed to use their input pins as enable functions also. If a timer is disabled, the count register does not increment when the counter element services the timer.

The Enable bit can be altered by programming or the timers can be programmed to disable themselves at the end of a counting sequence with the Continuous (CONT) bit. If the timer is not programmed for continuous operation, the Enable bit automatically clears at the end of a counting sequence. In single maximum count mode, this occurs after Maxcount Compare A is reached. In dual maximum count mode, this occurs after Maxcount Compare B is reached (Timers 0 and 1 only).

The input pins for Timers 0 and 1 provide an alternate method for enabling and disabling timer counting. When using internal clocking, the input pin can be programmed either to enable the timer or to reset the timer count, depending on the state of the Retrigger (RTG) bit in the control register. When used as an enable function, the input pin either allows (input high) or prevents (input low) timer counting. To ensure recognition of an input level, it must be valid for four CPU clocks. This is due to the counter element's time-multiplexed servicing scheme for the timers.

9.2.6 Timer Interrupts

All timers can generate internal interrupt requests. Although all three timers share a single interrupt request to the CPU, each has its own vector location and internal priority. Timer 0 has the highest interrupt priority and Timer 2 has the lowest.

Timer Interrupts are enabled or disabled by the Interrupt (INT) bit in the Timer Control register. If enabled, an interrupt is generated every time a maximum count value is reached. In dual maximum count mode, an interrupt is generated each time the value in Maxcount Compare A or Maxcount Compare B is reached. If the interrupt is disabled after a request has been generated, but before a pending interrupt is serviced, the interrupt request remains active (the Interrupt Controller latches the request). If a timer generates a second interrupt request before the CPU services the first interrupt request, the first request is lost.

9.2.7 Programming Considerations

Timer registers can be read or written whether the timer is operating or not. Since processor accesses to timer registers are synchronized with counter element accesses, a half-modified count register will never be read.

When Timer 0 and Timer 1 use an internal clock source, the input pin must be high to enable counting.

9.3 TIMING

Certain timing considerations need to be made with the Timer/Counter Unit. These include input setup and hold times, synchronization and operating frequency.

9.3.1 Input Setup and Hold Timings

To ensure recognition, setup and hold times must be met with respect to CPU clock edges. The timer input signal must be valid T_{CHIS} before the rising edge of CLKOUT and must remain valid T_{CHIH} after the same rising edge. If these timing requirements are not met, the input will not be recognized until the next clock edge.

9.3.2 Synchronization and Maximum Frequency

All timer inputs are latched and synchronized with the CPU clock. Because of the internal logic required to synchronize the external signals, and the multiplexing of the counter element, the Timer/Counter Unit can operate only up to $\frac{1}{4}$ of the CLKOUT frequency. Clocking at greater frequencies will result in missed clocks.

9.3.2.1 Timer/Counter Unit Application Examples

The following examples are possible applications of the Timer/Counter Unit. They include a real-time clock, a square wave generator and a digital one-shot.

9.3.3 Real-Time Clock

Example 9-1 contains sample code to configure Timer 2 to generate an interrupt request every 10 milliseconds. The CPU then increments memory-based clock variables.

9.3.4 Square-Wave Generator

A square-wave generator can be useful to act as a system clock tick. Example 9-2 illustrates how to configure Timer 1 to operate this way.

9.3.5 Digital One-Shot

Example 9-3 configures Timer 1 to act as a digital one-shot.

```

$mod186
name example_80186_family_timer_code

;FUNCTION:  This function sets up the timer and interrupt controller
;           to cause the timer to generate an interrupt every
;           10 milliseconds and to service interrupts to
;           implement a real time clock.
;
;           Timer 2 is used in this example because no input or
;           output signals are required.
;
;SYNTAX:    extern void far set_time(hour, minute, second, T2Compare)
;
;INPUTS:    hour - hour to set time to.
;           minute - minute to set time to.
;           second - second to set time to.
;           T2Compare - T2CMPA value (see note below)
;
;OUTPUTS:   None

;NOTE:      Parameters are passed on the stack as required by
;           high-level languages
;
;           For a CLKOUT of 16Mhz,
;
;           f(timer2)           = 16Mhz/4
;                               = 4Mhz
;                               = 0.25us for T2CMPA = 1
;
;           T2CMPA(10ms)       = 10ms/0.25us
;                               = 10e-3/0.25e-6
;                               = 40000

;substitute register offsets

T2CON    equ xxxxxh           ;Timer 2 Control register
T2CMPA   equ xxxxxh           ;Timer 2 Compare register
T2CNT    equ xxxxxh           ;Timer 2 Counter register
TCUCON   equ xxxxxh           ;Int. Control register
EOI      equ xxxxxh           ;End Of Interrupt register
INTSTS   equ xxxxxh           ;Interrupt Status register
timer_2_int equ 19            ;timer 2:vector type 19

data segment public 'data'

    public _hour, _minute, _second, _msec

    _hour    db ?
    _minute  db ?
    _second  db ?
    _msec    db ?

data ends

```

Example 9-1. Configuring a Real-Time Clock

```

lib_80186 segment public 'code'
    assume cs:lib_80186, ds:data

public _set_time
_set_time proc far

    push    bp                ;save caller's bp
    mov     bp, sp            ;get current top of stack

    hour    equ word ptr[bp+6] ;get parameters off stack
    minute  equ word ptr[bp+8]
    second  equ word ptr[bp+10]
    T2Compare equ word ptr[bp+12]

    push    ax                ;save registers used
    push    dx
    push    si

    push    ds
    xor     ax, ax            ;set interrupt vector
    mov     ds, ax
    mov     si, 4*timer_2_int
    mov     word ptr ds:[si], offset

timer_2_interrupt_routine
    inc     si
    inc     si
    mov     ds:[si], cs
    pop     ds

    mov     ax, hour          ;set time
    mov     _hour, al
    mov     ax, minute
    mov     _minute, al
    mov     ax, second
    mov     _second, al
    mov     _msec, 0

    mov     dx, T2CNT         ;clear Count register
    xor     ax, ax
    out     dx, al

    mov     dx, T2CMPA        ;set maximum count value
    mov     ax, T2Compare     ;see note in header above
    out     dx, al
    mov     dx, T2CON         ;set up the control word:
    mov     ax, 0E001H        ;enable counting,
    out     dx, al           ;generate interrupt on MC,
                             ;continuous counting

    mov     dx, TCUCON        ;set up interrupt controller
    xor     ax, ax           ;unmask highest priority interrupt
    out     dx, al

```

Example 9-1. Configuring a Real-Time Clock (Continued)

```

        sti                                ;enable interrupts

        pop     si                          ;restore saved registers
        pop     dx
        pop     ax
        pop     bp                          ;restore caller's bp
        ret
_set_time endp

timer_2_interrupt_routine proc far

        push   ax                          ;save registers used
        push   dx
        cmp    _msec, 99                   ;has 1 sec passed?
        jae    bump_second                 ;if above or equal...
        inc    _msec
        jmp    short reset_int_ctl

bump_second:
        mov    _msec, 0                    ;reset millisecond
        cmp    _minute, 59                 ;has 1 minute passed?
        jae    bump_minute
        inc    _second
        jmp    short reset_int_ctl

bump_minute:
        mov    _second, 0                  ;reset second
        cmp    _minute, 59                 ;has 1 hour passed?
        jae    bump_hour
        inc    _minute
        jmp    short reset_int_ctl

bump_hour:
        mov    _minute, 0                  ;reset minute
        cmp    _hour, 12                   ;have 12 hours passed?
        jae    reset_hour
        inc    _hour
        jmp    reset_int_ctl

reset_hour:
        mov    _hour, 1                    ;reset hour

reset_int_ctl:
        mov    dx, EOI
        mov    ax, 8000h                   ;non-specific end of interrupt
        out    dx, al
        pop    dx
        pop    ax
        iret

timer_2_interrupt_routine endp

lib_80186     ends
end

```

Example 9-1. Configuring a Real-Time Clock (Continued)

```

$mod186
name          example_timer1_square_wave_code

;FUNCTION:    This function generates a square wave of given
;            frequency and duty cycle on Timer 1 output pin.
;
; SYNTAX:     extern void far clock(int mark, int space)
;
; INPUTS:     mark - This is the mark (1) time.
;            space - This is the space (0) time.
;
;            The register compare value for a given time can be
;            easily calculated from the formula below.
;
;            CompareValue = (req_pulse_width*f)/4
;
; OUTPUTS:    None
;
; NOTE:       Parameters are passed on the stack as required by
;            high-level Languages

    TlCMPA equ xxxxH          ;substitute register offsets
    TlCMPB equ xxxxH
    TlCNT  equ xxxxH
    TlCON  equ xxxxH

lib_80186 segment public 'code'
    assume cs:lib_80186

public      _clock
_clock     proc far

    push    bp                ;save caller's bp
    mov     bp, sp            ;get current top of stack
    _space equ word ptr[bp+6] ;get parameters off the stack
    _mark  equ word ptr[bp+8]

    push    ax                ;save registers that will be
    push    bx                ;modified
    push    dx

    mov     dx, TlCMPA        ;set mark time
    mov     ax, _mark
    out    dx, al

    mov     dx, TlCMPB        ;set space time
    mov     ax, _space
    out    dx, al

    mov     dx, TlCNT         ;Clear Timer 1 Counter
    xor     ax, ax
    out    dx, al

    mov     dx, TlCON         ;start Timer 1
    mov     ax, C003H
    out    dx, al

```

Example 9-2. Configuring a Square-Wave Generator

```

    pop    dx                ;restore saved registers
    pop    bx
    pop    ax

    pop    bp                ;restore caller's bp
    ret

_clock   endp
lib_80186 ends
end

```

Example 9-2. Configuring a Square-Wave Generator (Continued)

```

$mod186
name example_timer1_1_shot_code

; FUNCTION: This function generates an active-low one-shot pulse
;           on Timer 1 output pin.
;
; SYNTAX:   extern void far one_shot(int CMPB);
;
; INPUTS:   CMPB - This is the TlCMPB value required to generate a
;           pulse of a given pulse width. This value is calculated
;           from the formula below.
;
;            $CMPB = (req\_pulse\_width * f) / 4$ 
;
; OUTPUTS:  None
;
; NOTE:     Parameters are passed on the stack as required by
;           high-level languages

    TlCNT   equ xxxxxH        ;substitute register offsets
    TlCMPA  equ xxxxxH
    TlCMPB  equ xxxxxH
    TlCON   equ xxxxxH
    MaxCount equ 0020H

lib_80186 segment public 'code'
    assume cs:lib_80186

public    _one_shot
_one_shot proc far

    push   bp                ;save caller's bp
    mov    bp, sp           ;get current top of stack

```

Example 9-3. Configuring a Digital One-Shot

```

    _CMPB equ word ptr[bp+6]    ;get parameter off the stack

    push  ax                    ;save registers that will be
    push  dx                    ;modified
    mov   dx, TlCNT             ;Clear Timer 1 Counter
    xor   ax, ax
    out   dx, al
    mov   dx, TlCMPA           ;set time before t_shot to 0
    mov   ax, 1
    out   dx, al
    mov   dx, TlCMPB           ;set pulse time
    mov   ax, _CMPB
    out   dx, al
    mov   dx, TlCON
    mov   ax, C002H            ;start Timer 1
    out   dx, al

CountDown: in ax, dx            ;read in TlCON
    test  ax, MaxCount         ;max count occurred?
    jz    CountDown           ;no: then wait
    and   ax, not MaxCount     ;clear max count bit
    out   dx, al              ;update TlCON

    pop   dx                    ;restore saved registers
    pop   ax
    pop   bp                    ;restore caller's bp
    ret

_one_shot endp
lib_80186 ends
end

```

Example 9-3. Configuring a Digital One-Shot (Continued)



10

**Direct Memory
Access Unit**



CHAPTER 10

DIRECT MEMORY ACCESS UNIT

In many applications, large blocks of data must be transferred between memory and I/O space. A disk drive, for example, usually reads and writes data in blocks that may be thousands of bytes long. If the CPU were required to handle each byte of the transfer, the main tasks would suffer a severe performance penalty. Even if the data transfers were interrupt driven, the overhead for transferring control to the interrupt handler would still decrease system throughput.

Direct Memory Access, or DMA, allows data to be transferred between memory and peripherals **without the intervention of the CPU**. Systems that use DMA have a special device, known as the DMA controller, that takes control of the system bus and performs the transfer between memory and the peripheral device. When the DMA controller receives a request for a transfer from a peripheral, it signals the CPU that it needs control of the system bus. The CPU then releases control of the bus and the DMA controller performs the transfer. In many cases, the CPU releases the bus and continues to execute instructions from the prefetch queue. If the DMA transfers are relatively infrequent, there is no degradation of software performance; the DMA transfer is transparent to the CPU.

The DMA Unit has two channels. Each channel can accept DMA requests from one of three sources: an external request pin, the Timer/Counter Unit or direct programming. Data can be transferred between any combination of memory and I/O space. The DMA Unit can access the entire memory and I/O space in either byte or word increments.

10.1 FUNCTIONAL OVERVIEW

The DMA Unit consists of two channels that are functionally identical. The following discussion is hierarchical, beginning with an overview of a single channel and ending with a description of the two-channel unit.

10.1.1 The DMA Transfer

A DMA transfer begins with a request. The requesting device may either have data to transmit (a source request) or it may require data (a destination request). Alternatively, transfers may be initiated by the system software without an external request.

When the DMA request is granted, the Bus Interface Unit provides the bus signals for the DMA transfer, while the DMA channel provides the address information for the source and destination devices. The DMA Unit does not provide a discrete DMA acknowledge signal, unlike other DMA controller chips (an acknowledge can be synthesized, however). The DMA channel continues transferring data as long as the request is active and it has not exceeded its programmed transfer limit.

Every DMA transfer consists of two distinct bus cycles: a fetch and a deposit (see Figure 10-1 on page 10-2). During the fetch cycle, the byte or word is read from the data source and placed in an internal temporary storage register. The data in the temporary storage register is written to the destination during the deposit cycle. The two bus cycles are indivisible; they cannot be separated by a bus hold request, a refresh request or another DMA request.

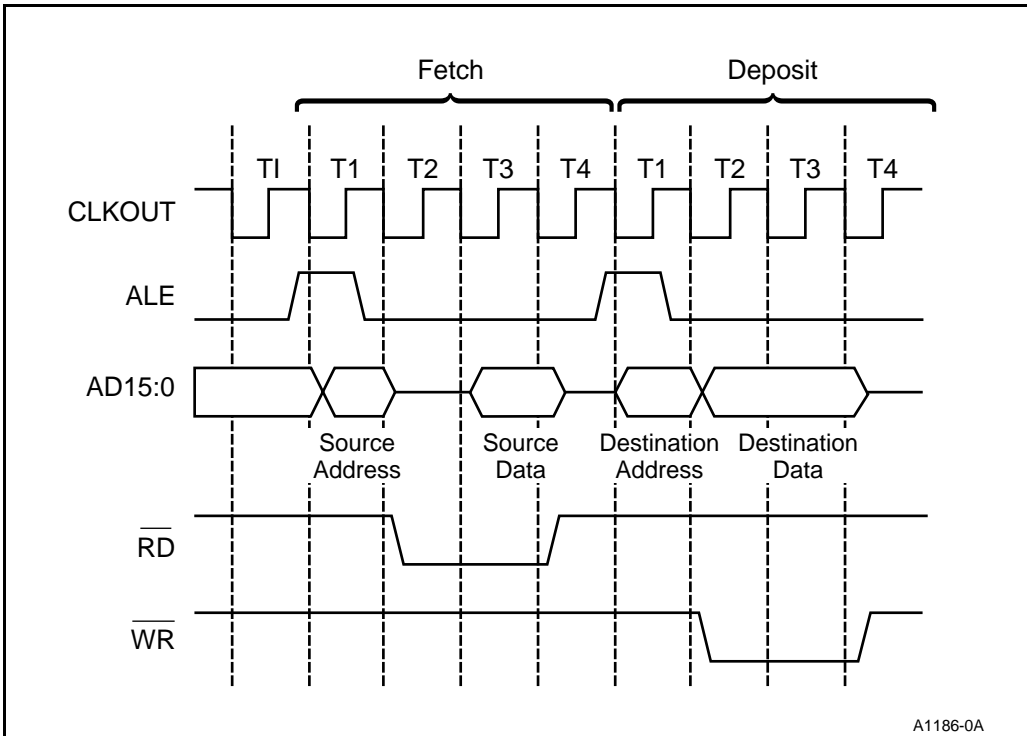

Figure 10-1. Typical DMA Transfer

10.1.1.1 DMA Transfer Directions

The source and destination addresses for a DMA transfer are programmable and can be in either memory or I/O space. DMA transfers can be programmed for any of the following four directions:

- from memory space to I/O space
- from I/O space to memory space
- from memory space to memory space
- from I/O space to I/O space

DMA transfers can access the Peripheral Control Block.

10.1.1.2 Byte and Word Transfers

DMA transfers can be programmed to handle either byte or word transfers. The handling of byte and word data is the same as that for normal bus cycles and is dependent upon the processor bus width. For example, odd-aligned word DMA transfers on a processor with a 16-bit bus requires two fetches and two deposits (all back-to-back). BIU bus cycles are covered in Chapter 3, “Bus Interface Unit.” Word transfers are illegal on the 8-bit bus device.

10.1.2 Source and Destination Pointers

Each DMA channel maintains a twenty-bit pointer for the source of data and a twenty-bit pointer for the destination of data. The twenty-bit pointers allow access to the full 1 Mbyte of memory space. The DMA Unit views memory as a linear (unsegmented) array.

With a twenty-bit pointer, it is possible to create an I/O address that is above the CPU limit of 64 Kbytes. The DMA Unit will run I/O DMA cycles above 64K, even though these addresses are not accessible through CPU instructions (e.g., IN and OUT). Some applications may wish to make use of this by swapping pages of data from I/O space above 64K to standard CPU memory.

The source and destination pointers can be individually programmed to increment, decrement or remain constant after each transfer. The programmed data width (byte or word) determines the amount that a pointer is incremented or decremented. Word transfers change the pointer by two; byte transfers change the pointer by one.

10.1.3 DMA Requests

There are three distinct sources of DMA requests: the external DRQ pin, the internal DMA request line and the system software. In all three cases, the system software must *arm* a DMA channel before it recognizes DMA requests. (See “Arming the DMA Channel” on page 10-18.)

10.1.4 External Requests

External DMA requests are asserted on the DRQ pins. The DRQ pins are sampled on the falling edge of CLKOUT. It takes a minimum of four clocks before the DMA cycle is initiated by the BIU (see Figure 10-2). The DMA request is cleared four clocks before the end of the DMA cycle (effectively re-arming the DRQ input).

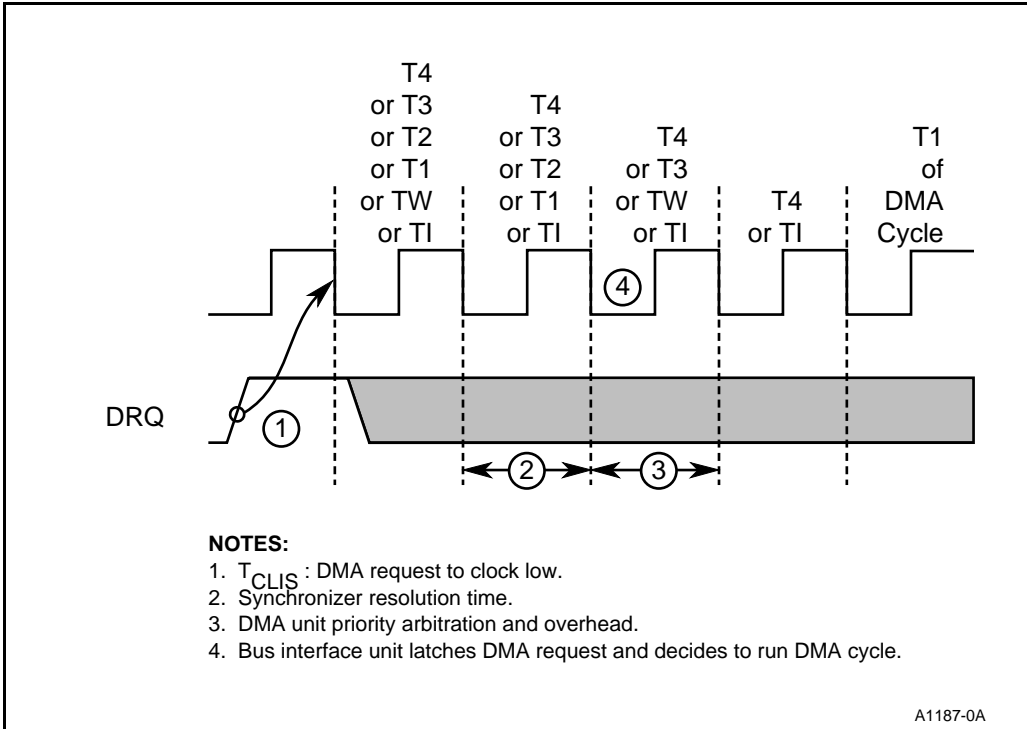

Figure 10-2. DMA Request Minimum Response Time

External requests (and the resulting DMA transfer) are classified as either source-synchronized or destination-synchronized. A source-synchronized request originates from the peripheral that is **sending** data. For example, a disk controller in the process of reading data from a disk would use a source-synchronized request (data would be moving from the disk to memory). A destination-synchronized request originates from the peripheral that is **receiving** data. If a disk controller were writing data to a disk, it would use a destination-synchronized request (data would be moving from memory to the disk). The type of synchronization a channel uses is programmable. (See “Selecting Channel Synchronization” on page 10-18.)

10.1.4.1 Source Synchronization

A typical source-synchronized transfer is shown in Figure 10-3. Most DMA-driven peripherals deassert their DRQ line only after the DMA transfer has begun. The DRQ signal must be deasserted at least four clocks before the end of the DMA transfer (at the T1 state of the deposit phase) to prevent another DMA cycle from occurring. A source-synchronized transfer provides the source device at least three clock cycles from the time it is accessed (acknowledged) to deassert its request line if further transfers are not required.

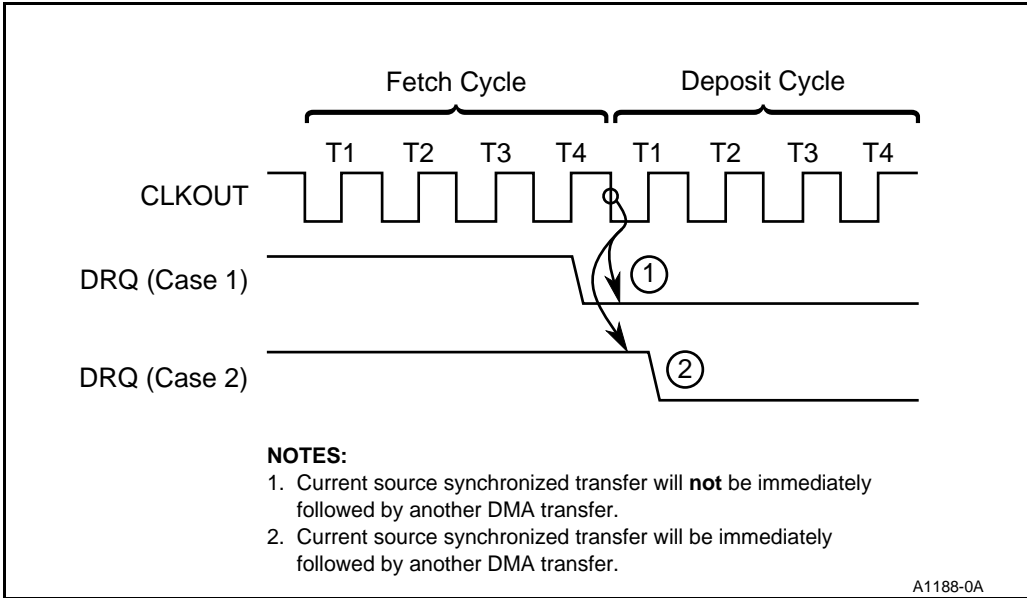

Figure 10-3. Source-Synchronized Transfers

10.1.4.2 Destination Synchronization

A destination-synchronized transfer differs from a source-synchronized transfer by the addition of two idle states at the end of the deposit cycle (Figure 10-4). The two idle states extend the DMA cycle to allow the destination device to deassert its DRQ pin four clocks before the end of the cycle. If the two idle states **were not** inserted, the destination device would not be able to deassert its request in time to prevent another DMA cycle from occurring.

The insertion of two idle states at the end of a destination synchronization transfer has an important side effect. **A destination-synchronized DMA channel gives up the bus during the idle states, allowing any other bus master to gain ownership.** This includes the CPU, the Refresh Control Unit, an external bus master or another DMA channel.

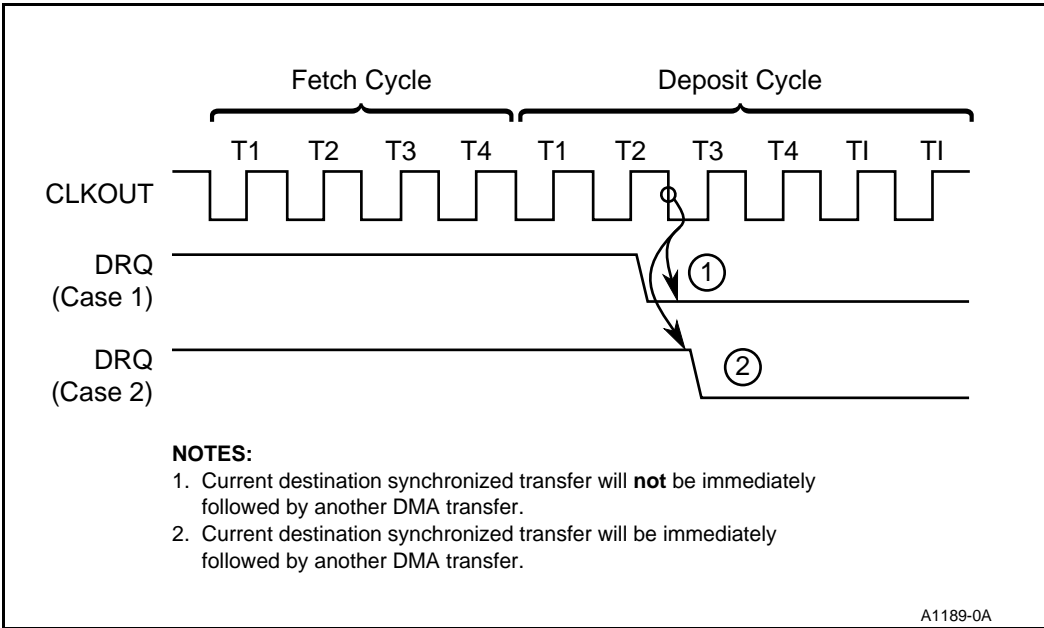

Figure 10-4. Destination-Synchronized Transfers

10.1.5 Internal Requests

Internal DMA requests can come from either Timer 2 or the system software.

10.1.5.1 Timer 2-Initiated Transfers

When programmed for Timer 2-initiated transfers, the DMA channel performs one DMA transfer every time that Timer 2 reaches its maximum count. Timer-initiated transfers are useful for servicing time-based peripherals. For example, an A/D converter would require data every 22 microseconds in order to produce an audio range waveform. In this case, the DMA source would point to the waveform data, the destination would point to the A/D converter and Timer 2 would request a transfer every 22 microseconds. (See “Timed DMA Transfers” on page 10-26.)

10.1.5.2 Unsynchronized Transfers

DMA transfers can be initiated directly by the system software by selecting unsynchronized transfers. Unsynchronized transfers continue, back-to-back, at the full bus bandwidth, until the channel’s transfer count reaches zero or DMA transfers are suspended by an NMI.

10.1.6 DMA Transfer Counts

Each DMA Unit maintains a programmable 16-bit transfer count value that controls the total number of transfers the channel runs. The transfer count is decremented by one after each transfer (regardless of data size). The DMA channel can be programmed to terminate transfers when the transfer count reaches zero (also referred to as *terminal count*).

10.1.7 Termination and Suspension of DMA Transfers

When DMA transfers for a channel are *terminated*, no further DMA requests for that channel will be granted until the channel is re-started by direct programming. A *suspended* DMA transfer temporarily disables transfers in order to perform a specific task. A suspended DMA channel does not need to be re-started by direct programming.

10.1.7.1 Termination at Terminal Count

When programmed to terminate on terminal count, the DMA channel disarms itself when the transfer count value reaches zero. No further DMA transfers take place on the channel until it is re-armed by direct programming. Unsynchronized transfers **always** terminate when the transfer count reaches zero, regardless of programming.

10.1.7.2 Software Termination

A DMA channel can be disarmed by direct programming. Any DMA transfer that is in progress will complete, but no further transfers are run until the channel is re-armed.

10.1.7.3 Suspension of DMA During NMI

DMA transfers are inhibited during the service of Non-Maskable Interrupts (NMI). DMA activity is halted in order to give the CPU full command of the system bus during the NMI service. Exit from the NMI via an IRET instruction re-enables the DMA Unit. DMA transfers can be enabled during an NMI service routine by the system software.

10.1.7.4 Software Suspension

DMA transfers can be temporarily suspended by direct programming. In time-critical sections of code, such as interrupt handlers, it may be necessary to shut off DMA activity temporarily in order to give the CPU total control of the bus.

10.1.8 DMA Unit Interrupts

Each DMA channel can be programmed to generate an interrupt request when its transfer count reaches zero.

10.1.9 DMA Cycles and the BIU

The DMA Unit uses the Bus Interface Unit to perform its transfers. When the DMA Unit has a pending request, it signals the BIU. If the BIU has no other higher-priority request pending, it runs the DMA cycle. (BIU priority is described in Chapter 3, “Bus Interface Unit.”) The BIU signals that it is running a bus cycle initiated by a master other than the CPU by driving the S6 status bit high.

The Chip-Select Unit monitors the BIU addresses to determine which chip-select, if any, to activate. Because the DMA Unit uses the BIU, chip-selects are active for DMA cycles. If a DMA channel accesses a region of memory or I/O space within a chip-select’s programmed range, then that chip-select is asserted during the cycle. The Chip-Select Unit will not recognize DMA cycles that access I/O space above 64K.

10.1.10 The Two-Channel DMA Unit

Two DMA channels are combined with arbitration logic to form the DMA Unit (see Figure 10-5).

10.1.10.1 DMA Channel Arbitration

Within the two-channel DMA Unit, the arbitration logic decides which channel takes precedence when both channels simultaneously request transfers. Each channel can be set to either low priority or high priority. If the two channels are set to the same priority (either both high or both low), then the channels rotate priority.

10.1.10.1.1 Fixed Priority

Fixed priority results when one channel in a module is programmed to high priority and the other is set to low priority. If both DMA requests occur simultaneously, the high priority channel performs its transfer (or transfers) first. The high priority channel continues to perform transfers as long as the following conditions are met:

- the channel’s DMA request is still active
- the channel has not terminated or suspended transfers (through programming or interrupts)
- the channel has not released the bus (through the insertion of idle states for destination-synchronized transfers)

The last point is extremely important when the two channels use different synchronization. For example, consider the case in which channel 1 is programmed for high priority and destination synchronization and channel 0 is programmed for low priority and source synchronization. If a DMA request occurs for both channels simultaneously, channel 1 performs the first transfer. At the end of channel 1's deposit cycle, two idle states are inserted (thus releasing the bus). With the bus released, channel 0 is free to perform its transfer **even though the higher-priority channel has not completed all of its transfers**. Channel 1 regains the bus at the end of channel 0's transfer. The transfers will alternate as long as both requests remain active.

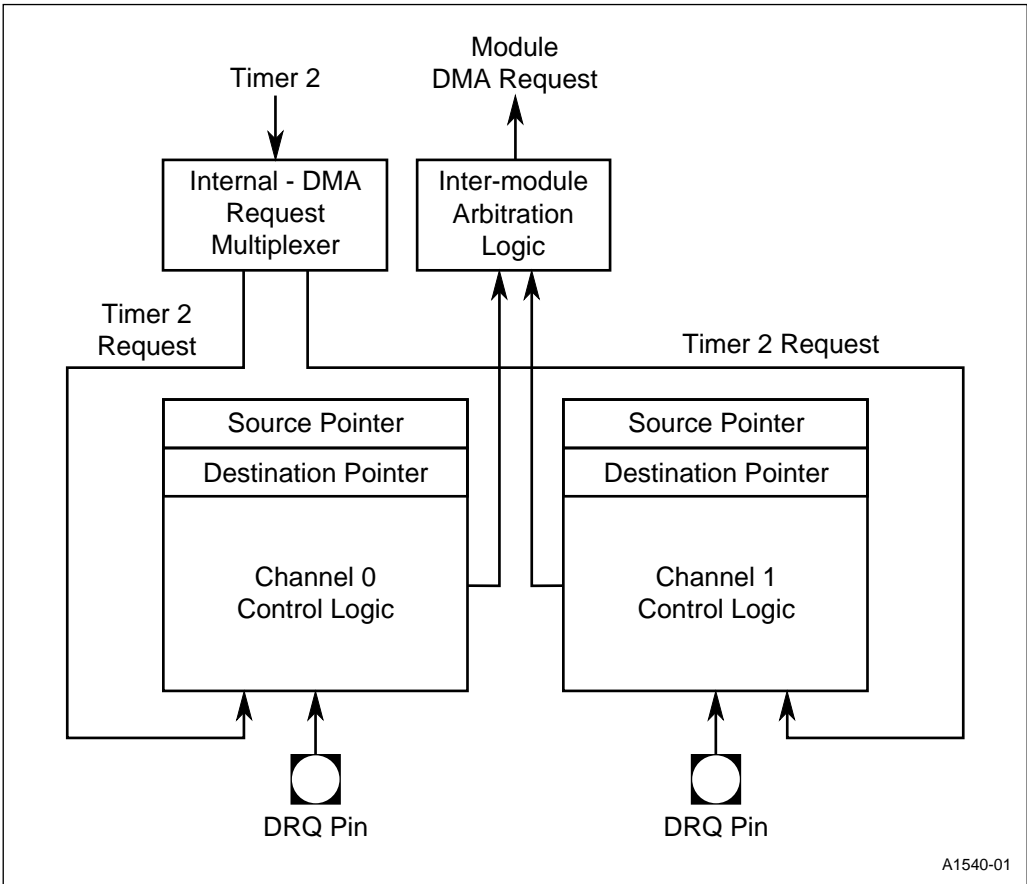

Figure 10-5. Two-Channel DMA Module

A higher-priority DMA channel will interrupt the transfers of a lower-priority channel. Figure 10-6 shows several transfers with different combinations of channel priority and synchronization.

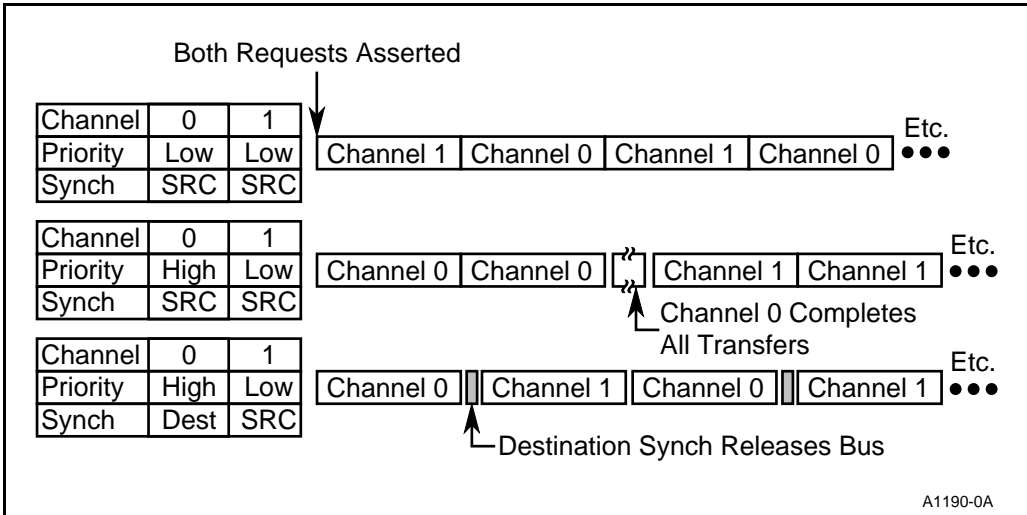

Figure 10-6. Examples of DMA Priority

10.1.10.1.2 Rotating Priority

Channel priority rotates when the channels are programmed as both high or both low priority. The highest priority is initially assigned to channel 1 of the module. After a channel performs a transfer, it is assigned the lower priority. When requests are active for both channels, the transfers alternate between the two. Channel 1 is reassigned high priority whenever the bus is released (that is, at the end of a destination-synchronized transfer or when DMA requests are no longer active).

10.2 PROGRAMMING THE DMA UNIT

A total of six Peripheral Control Block registers configure each DMA channel.

10.2.1 DMA Channel Parameters

The first step in programming the DMA Unit is to set up the parameters for each channel.

10.2.1.1 Programming the Source and Destination Pointers

The following parameters are programmable for the source and destination pointers:

- pointer address
- address space (memory or I/O)
- automatic pointer indexing (increment, decrement or no change) after transfer

Two 16-bit Peripheral Control Block registers define each of the 20-bit pointers. Figures 10.7 and 10.8 show the layout of the DMA Source Pointer address registers, and Figures 10.9 and 10.10 show the layout of the DMA Destination Pointer address registers. The DSA19:16 and DDA19:16 (high-order address bits) are driven on the bus even if I/O transfers have been programmed. When performing I/O transfers within the normal 64K I/O space **only**, the high-order bits in the pointer registers must be cleared.

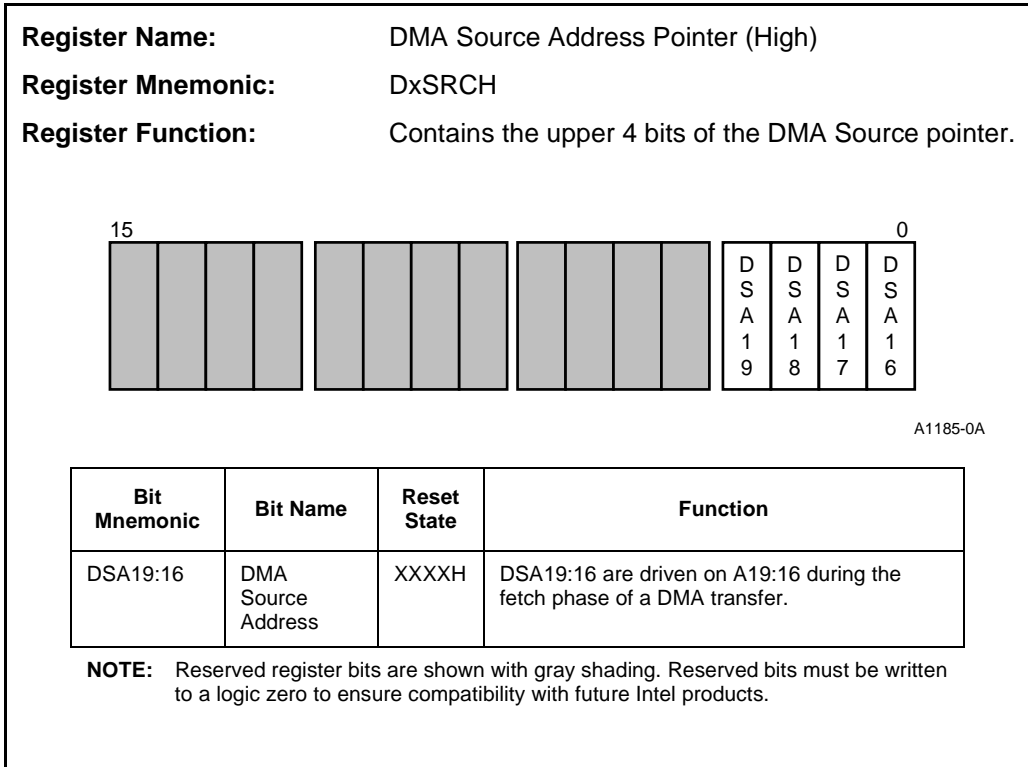
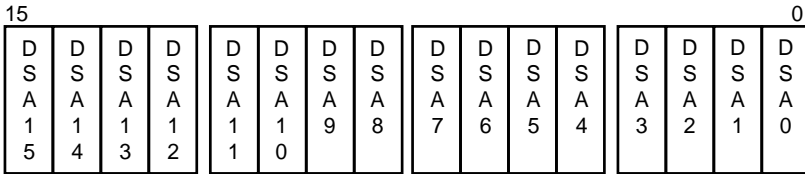

Figure 10-7. DMA Source Pointer (High-Order Bits)

Register Name: DMA Source Address Pointer (Low)
Register Mnemonic: DxSRCL
Register Function: Contains the lower 16 bits of the DMA Source pointer.



A1177-0A

Bit Mnemonic	Bit Name	Reset State	Function
DSA15:0	DMA Source Address	XXXXH	DSA15:0 are driven on the lower 16 bits of the address bus during the fetch phase of a DMA transfer.

Figure 10-8. DMA Source Pointer (Low-Order Bits)

The address space referenced by the source and destination pointers is programmed in the DMA Control Register for the channel (see Figure 10-11 on page 10-15). The SMEM and DMEM bits control the address space (memory or I/O) for source pointer and destination pointer, respectively.

Automatic pointer indexing is also controlled by the DMA Control Register. Each pointer has two bits, increment and decrement, that control the indexing. If the increment and decrement bits for a pointer are programmed to the same value, then the pointer remains constant. The programmed data width (byte or word) for the channel automatically controls the amount that a pointer is incremented or decremented.

Register Name: DMA Destination Address Pointer (High)
Register Mnemonic: DxDSTH
Register Function: Contains the upper 4 bits of the DMA Destination pointer.

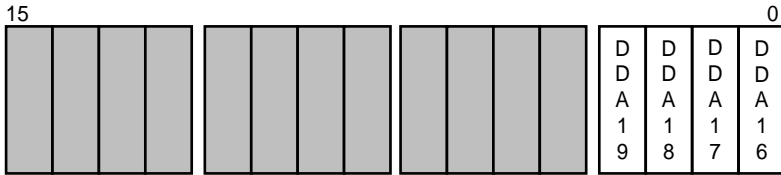

A1178-0A

Bit Mnemonic	Bit Name	Reset State	Function
DDA19:16	DMA Destination Address	XXXXH	DDA19:16 are driven on A19:16 during the deposit phase of a DMA transfer.

NOTE: Reserved register bits are shown with gray shading. Reserved bits must be written to a logic zero to ensure compatibility with future Intel products.

Figure 10-9. DMA Destination Pointer (High-Order Bits)

Register Name: DMA Destination Address Pointer (Low)
Register Mnemonic: DxDSTL
Register Function: Contains the lower 16 bits of the DMA Destination pointer.

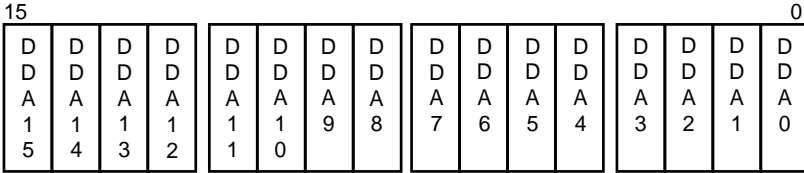

A1179-0A

Bit Mnemonic	Bit Name	Reset State	Function
DDA15:0	DMA Destination Address	XXXXH	DDA15:0 are driven on the lower 16 bits of the address bus during the deposit phase of a DMA transfer.

Figure 10-10. DMA Destination Pointer (Low-Order Bits)

10.2.1.2 Selecting Byte or Word Size Transfers

The WORD bit in the DMA Control Register (Figure 10-11) controls the data size for a channel. When WORD is set, the channel transfers data in 16-bit words. Byte transfers are selected by clearing the WORD bit. The data size for a channel also affects pointer indexing. Word transfers modify (increment or decrement) the pointer registers by two for each transfer, while byte transfers modify the pointer registers by one.

Register Name: DMA Control Register
Register Mnemonic: DxCON
Register Function: Controls DMA channel parameters.

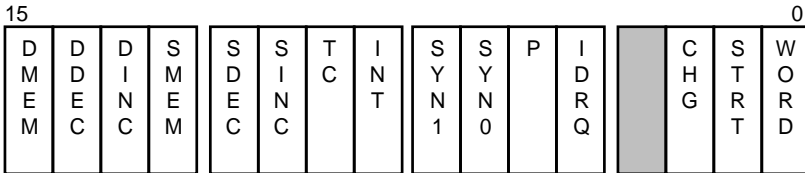

A1180-0A

Bit Mnemonic	Bit Name	Reset State	Function
DMEM	Destination Address Space Select	X	Selects memory or I/O space for the destination pointer. Set DMEM to select memory space; clear DMEM to select I/O space.
DDEC	Destination Decrement	X	Set DDEC to automatically decrement the destination pointer after each transfer. (See Note.)
DINC	Destination Increment	X	Set DINC to automatically increment the destination pointer after each transfer. (See Note.)
SMEM	Source Address Space Select	X	Selects memory or I/O space for the source pointer. Set SMEM to select memory space; clear SMEM to select I/O space.
SDEC	Source Decrement	X	Set SDEC to automatically decrement the source pointer after each transfer. (See Note.)
SINC	Source Increment	X	Set SINC to automatically increment the source pointer after each transfer. (See Note.)

NOTE: Reserved register bits are shown with gray shading. Reserved bits must be written to a logic zero to ensure compatibility with future Intel products. A pointer remains constant if its increment and decrement bits are equal.

Figure 10-11. DMA Control Register

Register Name: DMA Control Register
Register Mnemonic: DxCON
Register Function: Controls DMA channel parameters.

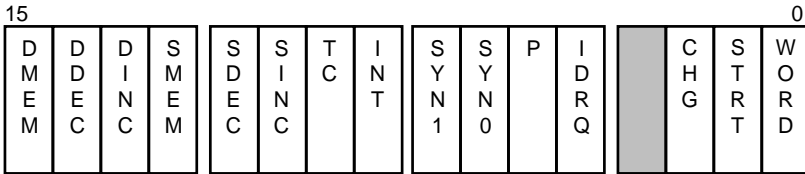

A1180-0A

Bit Mnemonic	Bit Name	Reset State	Function															
TC	Terminal Count	X	Set TC to terminate transfers on Terminal Count. This bit is ignored for unsynchronized transfers (that is, the DMA channel behaves as if TC is set, regardless of its condition).															
INT	Interrupt	X	Set INT to generate an interrupt request on Terminal Count. The TC bit must be set to generate an interrupt.															
SYN1:0	Synchronization Type	XX	Selects channel synchronization: <table border="1"> <thead> <tr> <th>SYN1</th> <th>SYN0</th> <th>Synchronization Type</th> </tr> </thead> <tbody> <tr> <td>0</td> <td>0</td> <td>Unsynchronized</td> </tr> <tr> <td>0</td> <td>1</td> <td>Source-synchronized</td> </tr> <tr> <td>1</td> <td>0</td> <td>Destination-synchronized</td> </tr> <tr> <td>1</td> <td>1</td> <td>Reserved (do not use)</td> </tr> </tbody> </table>	SYN1	SYN0	Synchronization Type	0	0	Unsynchronized	0	1	Source-synchronized	1	0	Destination-synchronized	1	1	Reserved (do not use)
SYN1	SYN0	Synchronization Type																
0	0	Unsynchronized																
0	1	Source-synchronized																
1	0	Destination-synchronized																
1	1	Reserved (do not use)																
P	Relative Priority	X	Set P to select high priority for the channel; clear P to select low priority for the channel.															
IDRQ	Internal DMA Request Select	X	Set IDRQ to select internal DMA requests and ignore the external DRQ pin. Clear IDRQ to select the DRQ pin as the source of DMA requests. When IDRQ is set, the channel must be configured for source-synchronized transfers (SYN1:0 = 01).															

NOTE: Reserved register bits are shown with gray shading. Reserved bits must be written to a logic zero to ensure compatibility with future Intel products.

Figure 10-11. DMA Control Register (Continued)

Register Name: DMA Control Register
Register Mnemonic: DxCON
Register Function: Controls DMA channel parameters.

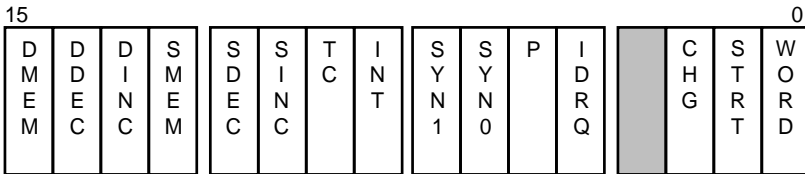

A1180-0A

Bit Mnemonic	Bit Name	Reset State	Function
CHG	Change Start Bit	X	Set CHG to enable modifying the STRT bit.
STRT	Start DMA Channel	0	Set STRT to arm the DMA channel. The STRT bit can be modified only when the CHG bit is set.
WORD	Word Transfer Select	X	Set WORD to select word transfers; clear WORD to select byte transfers. The 8-bit bus versions of the device ignore the WORD bit.

NOTE: Reserved register bits are shown with gray shading. Reserved bits must be written to a logic zero to ensure compatibility with future Intel products.

Figure 10-11. DMA Control Register (Continued)

10.2.1.3 Selecting the Source of DMA Requests

DMA requests can come from either an internal source (Timer 2) or an external source.

Internal DMA requests are selected by setting the IDRQ bit in the DMA Control Register (see Figure 10-11 on page 10-15) for the channel. The DMA channel ignores its DRQ pin when internal requests are programmed. Similarly, the DMA channel responds only to the DRQ pin (and ignores internal requests) when external requests are selected.

10.2.1.4 Arming the DMA Channel

Each DMA channel must be armed before it can recognize DMA requests. A channel is armed by setting its STRT (Start) bit in the DMA Control Register (Figure 10-11 on page 10-15). The STRT bit can be modified only if the CHG (Change Start) bit is set at the same time. The CHG bit is a safeguard to prevent accidentally arming a DMA channel while modifying other channel parameters.

A DMA channel is disarmed by clearing its STRT bit. The STRT bit is cleared either directly by software or by the channel itself when it is programmed to terminate on terminal count.

10.2.1.5 Selecting Channel Synchronization

The synchronization method for a channel is controlled by the SYN1:0 bits in the DMA Control Register (Figure 10-11 on page 10-15).

NOTE

The combination SYN1:0=11 is reserved and will result in unpredictable operation. When IDRQ is set (internal requests selected) the channel must always be programmed for source-synchronized transfers (SYN1:0=01).

When programmed for unsynchronized transfers (SYN1:0=00), the DMA channel will begin to transfer data as soon as the STRT bit is set.

10.2.1.6 Programming the Transfer Count Options

The Transfer Count Register (Figure 10-12) and the TC bit in the DMA Control Register (Figure 10-11 on page 10-15) are used to stop DMA transfers for a channel after a specified number of transfers have occurred.

The transfer count (the number of transfers desired) is written to the DMA Transfer Count Register. The Transfer Count Register is 16 bits wide, limiting the total number of transfers for a channel to 65,536 (without reprogramming). The Transfer Count Register is decremented by one after each transfer (for both byte and word transfers).

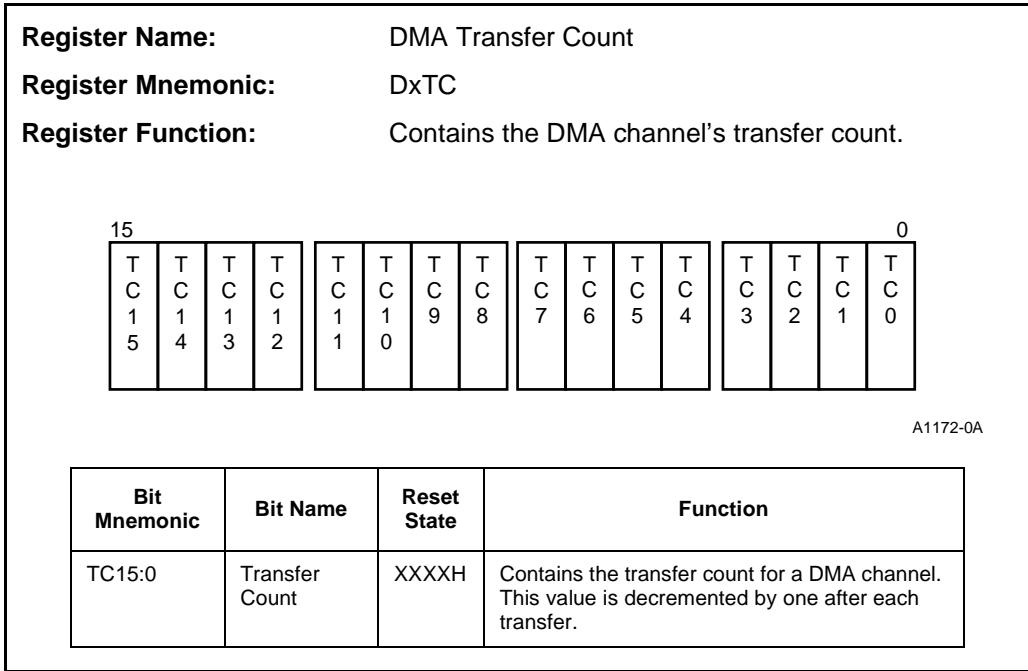

Figure 10-12. Transfer Count Register

The TC bit, when set, instructs the DMA channel to disarm itself (by clearing the STRT bit) when the transfer count reaches zero. If the TC bit is cleared, the channel continues to perform transfers regardless of the state of the Transfer Count Register. Unsynchronized (software-initiated) transfers always terminate when the transfer count reaches zero; the TC bit is ignored.

10.2.1.7 Generating Interrupts on Terminal Count

A channel can be programmed to generate an interrupt request whenever the transfer count reaches zero. Both the TC bit and the INT bit in the DMA Control Register (Figure 10-11 on page 10-15) must be set to generate an interrupt request.

10.2.1.8 Setting the Relative Priority of a Channel

The priority of a channel is controlled by the Priority bit in the DMA Control Register (Figure 10-11 on page 10-15). A channel may be assigned either high or low priority. If both channels are programmed to the same priority (i.e., both high or both low), the channels rotate priority.

10.2.2 Suspension of DMA Transfers

Whenever the CPU receives an NMI, all DMA activity is suspended at the end of the current transfer. The CPU suspends DMA activity by setting the DHLT bit in the Interrupt Status Register (Figure 8-14 on page 8-23). When an IRET instruction is executed, the CPU clears the DHLT bit and DMA transfers are allowed to resume. Software can read and write the DHLT bit.

NOTE

Do not write to the DHLT bit while Timer/Counter Unit interrupts are enabled. A conflict with the internal use of the register may cause incorrect processing of timer interrupts.

The DHLT bit does not function when the interrupt controller is in slave mode.

10.2.3 Initializing the DMA Unit

Use the following sequence when programming the DMA Unit:

1. Program the source and destination pointers for all used channels.
2. Program the DMA Control Registers in order of highest-priority channel to lowest-priority channel.

10.3 HARDWARE CONSIDERATIONS AND THE DMA UNIT

This section covers hardware interfacing and performance factors for the DMA Unit.

10.3.1 DRQ Pin Timing Requirements

The DRQ pins are sampled on the falling edge of CLKOUT. The DRQ pins must be set up a minimum of T_{CLIS} before CLKOUT falling and must be held a minimum of T_{CLIH} after CLKOUT falls. Refer to the data sheet for specific values.

The DRQ pins have an internal synchronizer. Violating the setup and hold times can cause only a missed DMA request, not a processor malfunction.

10.3.2 DMA Latency

DMA Latency is the delay between a DMA request being asserted and the DMA cycle being run. The DMA latency for a channel is controlled by many factors:

- **Bus HOLD** — Bus HOLD takes precedence over internal DMA requests. Using bus HOLD will degrade DMA latency.
- **LOCKed Instructions** — Long LOCKed instructions (e.g., LOCK REP MOVS) will monopolize the bus, preventing access by the DMA Unit.
- **Inter-channel Priority Scheme** — Setting a channel at low priority will affect its latency.

The minimum latency in all cases is four CLKOUT cycles. This is the amount of time it takes to synchronize and prioritize a request.

10.3.3 DMA Transfer Rates

The maximum DMA transfer rate is a function of processor operating frequency and synchronization mode. For unsynchronized and source-synchronized transfers, the 80C186 Modular Core can transfer two bytes every eight CLKOUT cycles. For destination-synchronized transfers, the addition of two idle T-states reduces the bandwidth by two clocks per word.

Maximum DMA transfer rates (in Mbytes per second) for the 80C186 Modular Core are calculated by the following equations, where F_{CPU} is the CPU operating frequency (in megahertz).

For unsynchronized and source-synchronized transfers:

$$0.25 \times F_{CPU}$$

For destination-synchronized transfers:

$$0.20 \times F_{CPU}$$

Because of its 8-bit data bus, the 80C188 Modular Core can transfer only one byte per DMA cycle. Therefore, the maximum transfer rates for the 80C188 Modular Core are half those calculated by the equations for the 80C186 Modular Core.

10.3.4 Generating a DMA Acknowledge

The DMA channels do not provide a distinct DMA acknowledge signal. A chip-select line can be programmed to activate for the memory or I/O range that requires the acknowledge. The chip-select must be programmed to activate only when a DMA is in progress. Latched status line S6 can be used as a qualifier to the chip-select for situations in which the chip-select line will be active for both DMA and normal data accesses.

10.4 DMA UNIT EXAMPLES

Example 10-1 sets up channel 0 to perform an unsynchronized burst transfer from memory to memory while channel 1 is used to service an external DMA request from a hard disk controller.

Example 10-2 shows timed DMA transfers. A sawtooth waveform is created using DMA transfers to an A/D converter.



```

$MOD186

name      DMA_EXAMPLE_1

; This example shows code necessary to set up two DMA channels.
; One channel performs an unsynchronized transfer from memory to memory.
; The second channel is used by a hard disk controller located in
; I/O space.

; It is assumed that the constants for PCB register addresses are
; defined elsewhere with EQUates.

CODE_SEG  SEGMENT
          ASSUME CS:CODE_SEG

START:    MOV     AX, DATA_SEG           ; DATA SEGMENT POINTER
          MOV     DS, AX
          ASSUME DS:DATA_SEG

; First we must initialize DMA channel 0. DMA0 will perform an
; unsynchronized transfer from SOURCE_DATA_1 to DEST_DATA_1.
; The first step is to calculate the proper values for the
; source and destination pointers.

          MOV     AX, SEG SOURCE_DATA_1

          ROL     AX, 4                   ; GET HIGH 4 BITS
          MOV     BX, AX                  ; SAVE ROTATED VALUE
          AND     AX, 0FFF0H             ; GET SHIFTED LOW 4 NIBBLES

          ADD     AX, OFFSET SOURCE_DATA_1
; NOW LOW BYTES OF POINTER ARE IN AX

          ADC     BX, 0                   ; ADD IN THE CARRY
                                          ; TO THE HIGH NIBBLE
          AND     BX, 000FH              ; GET JUST THE HIGH NIBBLE
          MOV     DX, D0SRCL
          OUT     DX, AL                  ; AX=LOW 4 BYTES

          MOV     DX, D0SRCH
          MOV     AX, BX                  ; GET HIGH NIBBLE
          OUT     DX, AX

; SOURCE POINTER DONE. REPEAT FOR DESTINATION.

          MOV     AX, SEG DEST_DATA_1

          ROL     AX, 4                   ; GET HIGH 4 BITS
          MOV     BX, AX                  ; SAVE ROTATED VALUE
          AND     AX, 0FFF0H             ; GET SHIFTED LOW 4 NIBBLES

          ADD     AX, OFFSET DEST_DATA_1
; NOW LOW BYTES OF POINTER ARE IN AX

          ADC     BX, 0                   ; ADD IN THE CARRY
                                          ; TO THE HIGH NIBBLE
          AND     BX, 000FH              ; GET JUST THE HIGH NIBBLE
          MOV     DX, D0DSTL
          OUT     DX, AX                  ; AX=LOW 4 BYTES

```

Example 10-1. Initializing the DMA Unit

```

MOV    DX, D0DSTH
MOV    AX, BX                ; GET HIGH NIBBLE
OUT    DX, AX

; THE POINTER ADDRESSES HAVE BEEN SET UP. NOW WE SET UP THE TRANSFER COUNT.

MOV    AX, 29                ; THE MESSAGE IS 29 BYTES LONG.
MOV    DX, D0TC              ; XFER COUNT REG
OUT    DX, AX

; NOW WE NEED TO SET THE PARAMETERS FOR THE CHANNEL AS FOLLOWS:
;
;
;     DESTINATION   SOURCE
;     -----
;     MEMORY SPACE MEMORY SPACE
;     INCREMENT PTR INCREMENT PTR
;
; TERMINATE ON TC, NO INTERRUPT, UNSYNCHRONIZED, LOW PRIORITY RELATIVE
; TO CHANNEL 1, BYTE XFERS. WE START THE CHANNEL.

MOV    AX, 1011011000000110B
MOV    DX, D0CON
OUT    DX, AX

; THE UNSYNCHRONIZED BURST IS NOW RUNNING ON THE BUS...
; NOW SET UP CHANNEL 1 TO SERVICE THE DISK CONTROLLER.
; FOR THIS EXAMPLE WE WILL ONLY BE READING FROM THE DISK.
; THE SOURCE IS THE I/O PORT FOR THE DISK CONTROLLER.

MOV    AX, DISK_IO_ADDR
MOV    DX, D1SRCL
OUT    DX, AX                ; PROGRAM LOW ADDR

XOR    AX, AX
MOV    DX, D1SRCH            ; HI ADDR FOR IO=0
OUT    DX, AX

; THE DESTINATION IS THE DISK BUFFER IN MEMORY

MOV    AX, SEG DISK_BUFF

ROL    AX, 4                 ; GET HIGH 4 BITS
MOV    BX, AX                ; SAVE ROTATED VALUE
AND    AX, 0FFF0H           ; GET SHIFTED LOW 4 NIBBLES

ADD    AX, OFFSET DISK_BUFF

; NOW LOW BYTES OF POINTER ARE IN AX

ADC    BX, 0                 ; ADD IN THE CARRY
; TO THE HIGH NIBBLE
AND    BX, 000FH            ; GET JUST THE HIGH NIBBLE
MOV    DX, D1DSTL
OUT    DX, AL                ; AX=LOW 4 BYTES
MOV    DX, D1DSTH
MOV    AX, BX                ; GET HIGH NIBBLE
OUT    DX, AX

; THE POINTER ADDRESSES HAVE BEEN SET UP. NOW WE SET UP THE TRANSFER COUNT.

```

Example 10-1. Initializing the DMA Unit (Continued)

```
SECTORS    MOV    AX, 512                ; THE DISK READS IN 512 BYTE
           MOV    DX, D1TC          ; XFER COUNT REG
           OUT    DX, AX

; NOW WE NEED TO SET THE PARAMETERS FOR THE CHANNEL AS FOLLOWS:
;
;           DESTINATION      SOURCE
;           -----
;           MEMORY SPACE    I/O SPACE
;           INCREMENT PTR   CONSTANT PTR
;
; TERMINATE ON TC, INTERRUPT, SOURCE SYNC, HIGH PRIORITY RELATIVE TO
; CHANNEL 0, BYTE XFERS, USE DRQ PIN FOR REQUEST SOURCE. ARM CHANNEL.

           MOV    AX, 1010001101100110B
           MOV    DX, D0CON
           OUT    DX, AX

; REQUESTS ON DRQ1 WILL NOW RESULT IN TRANSFERS

CODE_SEG   ENDS

DATA_SEG   SEGMENT

SOURCE_DATA_1DB '80C186EC INTEGRATED PROCESSOR'
DEST_DATA_1DB  30 DUP('MITCH')                ; JUNK DATA FOR TEST

DISK_BUFF  DB    512 DUP(?)

DATA_SEG   ENDS
           END START
```

Example 10-1. Initializing the DMA Unit (Continued)

```

$mod186
name      DMA_EXAMPLE_1

; This example sets up the DMA Unit to perform a transfer from memory to
; I/O space every 22 uS. The data is sent to an A/D converter.

; It is assumed that the constants for PCB register addresses are
; defined elsewhere with EQUates.

CODE_SEG  SEGMENT
          ASSUME CS:CODE_SEG

START:    MOV     AX, DATA_SEG           ; DATA SEGMENT POINTER
          MOV     DS, AX
          ASSUME DS:DATA_SEG

; First, set up the pointers. The source is in memory.

          MOV     AX, SEG WAVEFORM_DATA

          ROL     AX, 4                   ; GET HIGH 4 BITS
          MOV     BX, AX                  ; SAVE ROTATED VALUE
          AND     AX, 0FFF0H             ; GET SHIFTED LOW 4 NIBBLES

          ADD     AX, OFFSET WAVEFORM_DATA

; NOW LOW BYTES OF POINTER ARE IN AX.

          ADC     BX, 0                   ; ADD IN THE CARRY
                                          ; TO THE HIGH NIBBLE
          AND     BX, 000FH              ; GET JUST THE HIGH NIBBLE
          MOV     DX, D0SRCL
          OUT     DX, AX                  ; AX=LOW 4 BYTES

          MOV     DX, D0SRCH
          MOV     AX, BX                  ; GET HIGH NIBBLE
          OUT     DX, AX

          MOV     AX, DA_CNVTR           ; I/O ADDRESS OF D/A
          MOV     DX, D0DSTL
          OUT     DX, AX

          MOV     DX, D0DSTH
          XOR     AX, AX                  ; CLEAR HIGH NIBBLE
          OUT     DX, AX

; THE POINTER ADDRESSES HAVE BEEN SET UP. NOW WE SET UP THE TRANSFER COUNT.

          MOV     AX, 255                 ; 8-BIT D/A, SO WE SEND 256 BYTES
          MOV     DX, D0TC                ; TO GET A FULL SCALE
          OUT     DX, AX

; PROGRAM IDRQ MUX

          MOV     DX, DMAPRI
          MOV     AX, 00H                 ; TIMER2 IS IDRQ SOURCE
                                          ; MODULES HAVE EQUAL PRIORITY
          OUT     DX, AX

```

Example 10-2. Timed DMA Transfers

```
; NOW WE NEED TO SET THE PARAMETERS FOR THE CHANNEL AS FOLLOWS:
;
;           DESTINATION   SOURCE
;           -----
;           I/O SPACE     MEMORY SPACE
;           CONSTANT PTR  INCREMENT PTR
;
; TERMINATE ON TC, INTERRUPT, SOURCE SYNCHRONIZE, INTERNAL REQUESTS,
; LOW PRIORITY RELATIVE TO CHANNEL 1, BYTE XFERS.

        MOV   AX, 0001011101010110B
        MOV   DX, D0CON
        OUT   DX, AX

; NOW WE ASSUME THAT TIMER 2 HAS BEEN PROPERLY PROGRAMMED FOR A 22uS DELAY.
; WHEN THE TIMER IS STARTED, A DMA TRANSFER WILL OCCUR EVERY 22uS.

CODE_SEG  ENDS

DATA_SEG  SEGMENT

WAVEFORM_DATADB 0,1,2,3,4,5,6,7,8,9,10,11,12,13
                DB  14,15,16,17,18,19,20,21,22,23,24

; ETC., UP TO 255

DATA_SEG  ENDS

        END START
```

Example 10-2. Timed DMA Transfers (Continued)





11

Math Coprocessing



CHAPTER 11

MATH COPROCESSING

The 80C186 Modular Core Family meets the need for a general-purpose embedded microprocessor. In most data control applications, efficient data movement and control instructions are foremost and arithmetic performed on the data is simple. However, some applications do require more powerful arithmetic instructions and more complex data types than those provided by the 80C186 Modular Core.

11.1 OVERVIEW OF MATH COPROCESSING

Applications needing advanced mathematics capabilities have the following characteristics.

- Numeric data values are non-integral or vary over a wide range
- Algorithms produce very large or very small intermediate results
- Computations must be precise (i.e., calculations must retain several significant digits)
- Computations must be reliable without dependence on programmed algorithms
- Overall math performance exceeds that afforded by a general-purpose processor and software alone

For the 80C186 Modular Core family, the 80C187 math coprocessor satisfies the need for powerful mathematics. The 80C187 can increase the math performance of the microprocessor system by 50 to 100 times.

11.2 AVAILABILITY OF MATH COPROCESSING

The 80C186 Modular Core supports the 80C187 with a hardware interface under microcode control. However, not all proliferations support the 80C187. Some package types have insufficient leads to support the required external handshaking requirements. The 3-volt versions of the processor do not specify math coprocessing because the 80C187 has only a 5-volt rating. Please refer to the current data sheets for details.

To execute numerics instructions, the 80C186EA must exit reset in Numerics Mode. The processor checks its **TEST** pin at reset and automatically enters Numerics Mode if the math coprocessor is present.

The core has an Escape Trap (ET) bit in the PCB Relocation Register (Figure 4-1 on page 4-2) to control the availability of math coprocessing. If the ET bit is set, an attempted numerics execution results in a Type 7 interrupt. The 80C187 will not work with the 8-bit bus version of the processor because all 80C187 accesses must be 16-bit. The 80C188 Modular Core automatically traps ESC (numerics) opcodes to the Type 7 interrupt, regardless of Relocation Register programming.

11.3 THE 80C187 MATH COPROCESSOR

The 80C187's high performance is due to its 80-bit internal architecture. It contains three units: a Floating Point Unit, a Data Interface and Control Unit and a Bus Control Logic Unit. The foundation of the Floating Point Unit is an 8-element register file, which can be used either as individually addressable registers or as a register stack. The register file allows storage of intermediate results in the 80-bit format. The Floating Point Unit operates under supervision of the Data Interface and Control Unit. The Bus Control Logic Unit maintains handshaking and communications with the host microprocessor. The 80C187 has built-in exception handling.

The 80C187 executes code written for the Intel387™ DX and Intel387 SX math coprocessors. The 80C187 conforms to ANSI/IEEE Standard 754-1985.

11.3.1 80C187 Instruction Set

80C187 instructions fall into six functional groups: data transfer, arithmetic, comparison, transcendental, constant and processor control. Typical 80C187 instructions accept one or two operands and produce a single result. Operands are usually located in memory or the 80C187 stack. Some operands are predefined; for example, FSQRT always takes the square root of the number in the top stack element. Other instructions allow or require the programmer to specify the operand(s) explicitly along with the instruction mnemonic. Still other instructions accept one explicit operand and one implicit operand (usually the top stack element).

As with the basic (non-numerics) instruction set, there are two types of operands for coprocessor instructions, source and destination. Instruction execution does not alter a source operand. Even when an instruction converts the source operand from one format to another (for example, real to integer), the coprocessor performs the conversion in a work area to preserve the source operand. A destination operand differs from a source operand because the 80C187 can alter the register when it receives the result of the operation. For most destination operands, the coprocessor usually replaces the destinations with results.

11.3.1.1 Data Transfer Instructions

Data transfer instructions move operands between elements of the 80C187 register stack or between stack top and memory. Instructions can convert any data type to temporary real and load it onto the stack in a single operation. Conversely, instructions can convert a temporary real operand on the stack to any data type and store it to memory in a single operation. Table 11-1 summarizes the data transfer instructions.

Table 11-1. 80C187 Data Transfer Instructions

Real Transfers	
FLD	Load real
FST	Store real
FSTP	Store real and pop
FXCH	Exchange registers
Integer Transfers	
FILD	Integer load
FIST	Integer store
FISTP	Integer store and pop
Packed Decimal Transfers	
FBLD	Packed decimal (BCD) load
FBSTP	Packed decimal (BCD) store and pop

11.3.1.2 Arithmetic Instructions

The 80C187’s arithmetic instruction set includes many variations of add, subtract, multiply, and divide operations and several other useful functions. Examples include a simple absolute value and a square root instruction that executes faster than ordinary division. Other arithmetic instructions perform exact modulo division, round real numbers to integers and scale values by powers of two.

Table 11-2 summarizes the available operation and operand forms for basic arithmetic. In addition to the four normal operations, “reversed” instructions make subtraction and division “symmetrical” like addition and multiplication. In summary, the arithmetic instructions are highly flexible for these reasons:

- the 80C187 uses register or memory operands
- the 80C187 can save results in a choice of registers

Available data types include temporary real, long real, short real, short integer and word integer. The 80C187 performs automatic type conversion to temporary real.

Table 11-2. 80C187 Arithmetic Instructions

Addition	
FADD	Add real
FADDP	Add real and pop
FIADD	Integer add
Subtraction	
FSUB	Subtract real
FSUBP	Subtract real and pop
FISUB	Integer subtract
FSUBR	Subtract real reversed
FSUBRP	Subtract real reversed and pop
FISUBR	Integer subtract reversed
Multiplication	
FMUL	Multiply real
FMULP	Multiply real and pop
FIMUL	Integer multiply

Division	
FDIV	Divide real
FDIVP	Divide real and pop
FIDIV	Integer divide
FDIVR	Divide real reversed
FDIVRP	Divide real reversed and pop
FIDIVR	Integer divide reversed
Other Operations	
FSQRT	Square root
FSCALE	Scale
FPREM	Partial remainder
FRNDINT	Round to integer
FEXTRACT	Extract exponent and significand
FABS	Absolute value
FCHS	Change sign
FPREMI	Partial remainder (IEEE)

11.3.1.3 Comparison Instructions

Each comparison instruction (see Table 11-3) analyzes the stack top element, often in relationship to another operand. Then it reports the result in the Status Word condition code. The basic operations are compare, test (compare with zero) and examine (report tag, sign and normalization).

Table 11-3. 80C187 Comparison Instructions

FCOM	Compare real
FCOMP	Compare real and pop
FCOMPP	Compare real and pop twice
FICOM	Integer compare
FICOMP	Integer compare and pop
FTST	Test
FXAM	Examine
FUCOM	Unordered compare
FUCOMP	Unordered compare and pop
FUCOMPP	Unordered compare and pop twice

11.3.1.4 Transcendental Instructions

Transcendental instructions (see Table 11-4) perform the core calculations for common trigonometric, hyperbolic, inverse hyperbolic, logarithmic and exponential functions. Use prologue code to reduce arguments to a range accepted by the instruction. Use epilogue code to adjust the result to the range of the original arguments. The transcendentals operate on the top one or two stack elements and return their results to the stack.

Table 11-4. 80C187 Transcendental Instructions

FPTAN	Partial tangent
FPATAN	Partial arctangent
F2XM1	$2^x - 1$
FYL2X	$Y \log_2 X$
FYL2XP1	$Y \log_2 (X+1)$
FCOS	Cosine
FSIN	Sine
FSINCOS	Sine and Cosine

11.3.1.5 Constant Instructions

Each constant instruction (see Table 11-5) loads a commonly used constant onto the stack. The values have full 80-bit precision and are accurate to about 19 decimal digits. Since a temporary real constant occupies 10 memory bytes, the constant instructions, only 2 bytes long, save memory space.

Table 11-5. 80C187 Constant Instructions

FLDZ	Load + 0.1
FLD1	Load +1.0
FLDPI	Load
FLDL2T	Load $\log_2 10$
FLDL2E	Load $\log_2 e$
FLDLG2	Load $\log_{10} 2$
FLDLN2	Load $\log_e 2$

11.3.1.6 Processor Control Instructions

Computations do not use the processor control instructions; these instructions are available for activities at the operating system level. This group (see Table 11-6) includes initialization, exception handling and task switching instructions.

Table 11-6. 80C187 Processor Control Instructions

FINIT/FNINIT	Initialize processor	FLDENV	Load environment
FDISI/FNDISI	Disable interrupts	FSAVE/FNSAVE	Save state
FENI/FNENI	Enable interrupts	FRSTOR	Restore state
FLDCW	Load control word	FINCSTP	Increment stack pointer
FSTCW/FNSTCW	Store control word	FDECSTP	Decrement stack pointer
FSTSW/FNSTSW	Store status word	FFREE	Free register
FCLEX/FNCLEX	Clear exceptions	FNOP	No operation
FSTENV/FNSTENV	Store environment	FWAIT	CPU wait

11.3.2 80C187 Data Types

The microprocessor/math coprocessor combination supports seven data types:

- Word Integer — A signed 16-bit numeric value. All operations assume a 2's complement representation.
- Short Integer — A signed 32-bit numeric value (double word). All operations assume a 2's complement representation.
- Long Integer — A signed 64-bit numeric value (quad word). All operations assume a 2's complement representation.
- Packed Decimal — A signed numeric value contained in an 80-bit BCD format.
- Short Real — A signed 32-bit floating point numeric value.
- Long Real — A signed 64-bit floating point numeric value.
- Temporary Real — A signed 80-bit floating point numeric value. Temporary real is the native 80C187 format.

Figure 11-1 graphically represents these data types.

11.4 MICROPROCESSOR AND COPROCESSOR OPERATION

The 80C187 interfaces directly to the microprocessor (as shown in Figure 11-2) and operates as an I/O-mapped slave peripheral device. Hardware handshaking requires connections between the 80C187 and four special pins on the processor: $\overline{\text{NCS}}$, BUSY , $\overline{\text{PEREQ}}$ and $\overline{\text{ERROR}}$. These pins are multiplexed with $\overline{\text{MCS3}}$, $\overline{\text{TEST}}$, $\overline{\text{MCS0}}$, and $\overline{\text{MCS1}}$, respectively. When the processor leaves reset, the presence of the 80C187 automatically places the processor in Numerics Mode and configures the pins correctly. $\overline{\text{MCS2}}$ retains its function as a chip-select and the processor retains the wait state and ready programming for the entire mid-range memory block, even though $\overline{\text{MCS0}}$, $\overline{\text{MCS1}}$ and $\overline{\text{MCS3}}$ are no longer available.

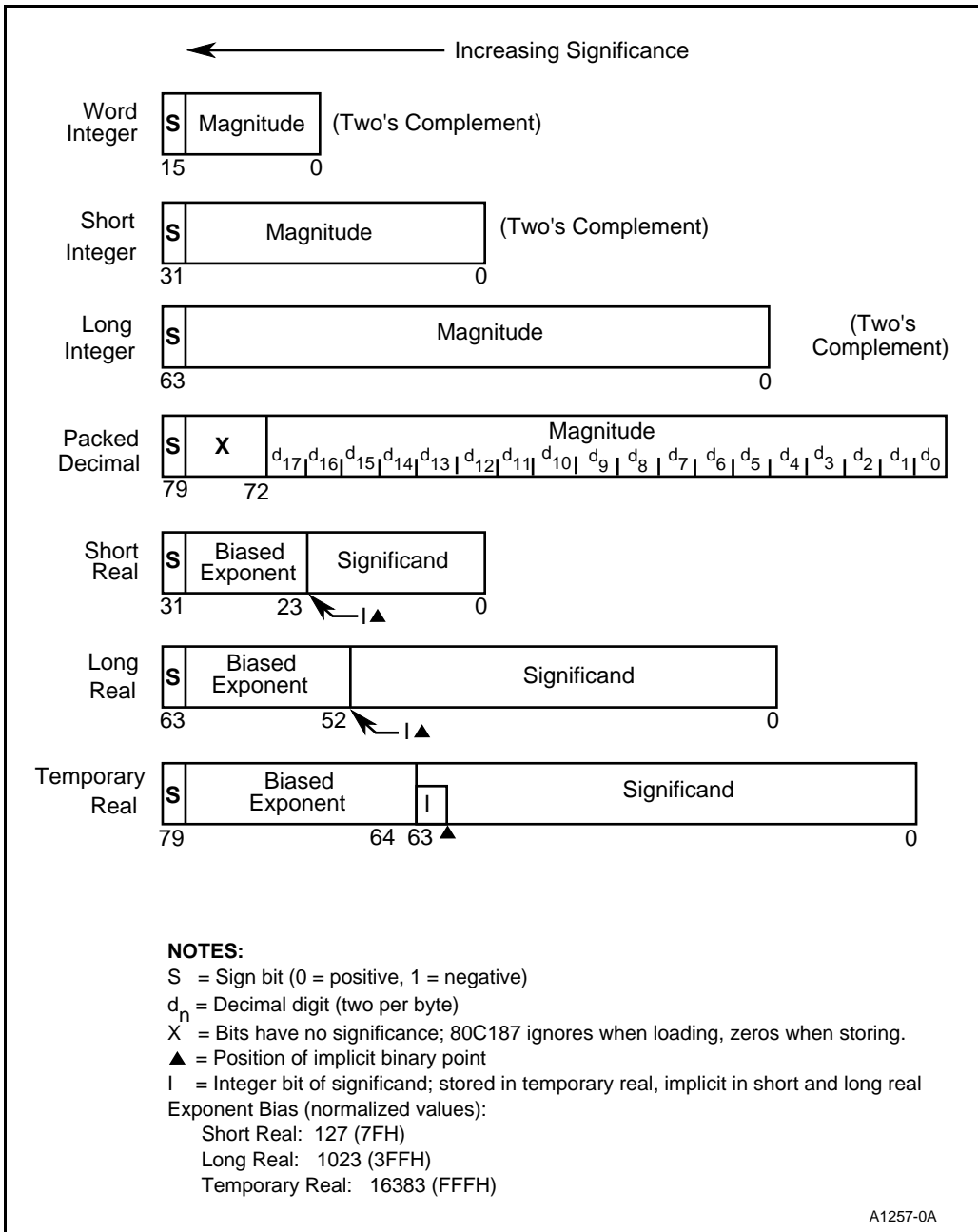

A1257-0A

Figure 11-1. 80C187-Supported Data Types

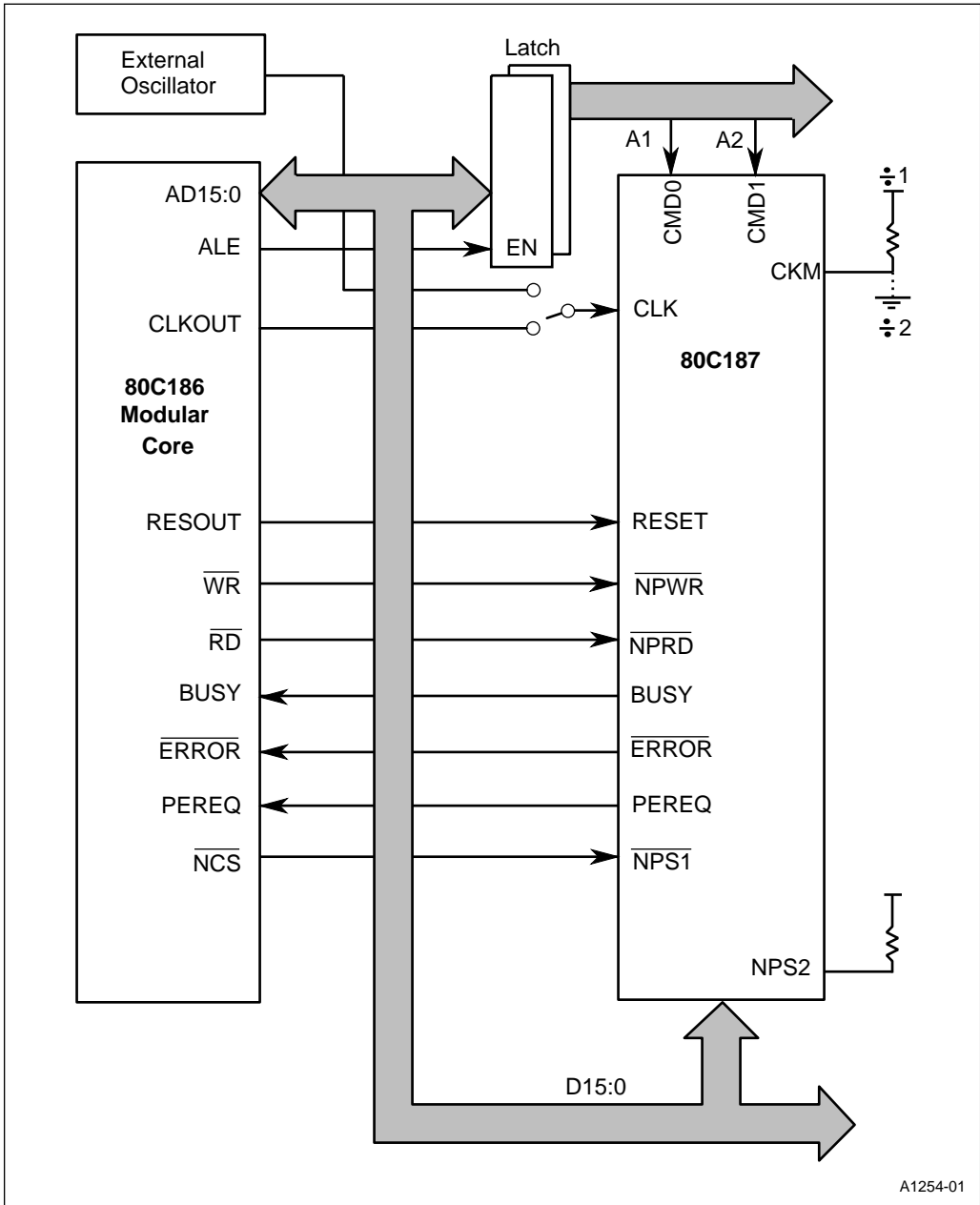

A1254-01

11.4.1 Clocking the 80C187

The microprocessor and math coprocessor operate asynchronously, and their clock rates may differ. The 80C187 has a CKM pin that determines whether it uses the input clock directly or divided by two. Direct clocking works up to 12.5 MHz, which makes it convenient to feed the clock input from the microprocessor's CLKOUT pin. Beyond 12.5 MHz, the 80C187 must use a multiply-by-two clock input up to a maximum of 32 MHz. The microprocessor and the math coprocessor have correct timing relationships, even with operation at different frequencies.

11.4.2 Processor Bus Cycles Accessing the 80C187

Data transfers between the microprocessor and the 80C187 occur through the dedicated, 16-bit I/O ports shown in Table 11-7. When the processor encounters a numerics opcode, it first writes the opcode to the 80C187. The 80C187 decodes the instruction and passes elementary instruction information (Opcode Status Word) back to the processor. Since the 80C187 is a slave processor, the Modular Core processor performs all loads and stores to memory. Including the overhead in the microprocessor's microcode, each data transfer between memory and the 80C187 (via the microprocessor) takes at least 17 processor clocks.

Table 11-7. 80C187 I/O Port Assignments

I/O Address	Read Definition	Write Definition
00F8H	Status/Control	Opcode
00FAH	Data	Data
00FCH	Reserved	CS:IP, DS:EA
00FEH	Opcode Status	Reserved

The microprocessor cannot process any numerics (ESC) opcodes alone. If the CPU encounters a numerics opcode when the Escape Trap (ET) bit in the Relocation Register is a zero and the 80C187 is not present, its operation is indeterminate. Even the FINIT/FNINIT initialization instruction (used in the past to test the presence of a coprocessor) fails without the 80C187. If an application offers the 80C187 as an option, problems can be prevented in one of three ways:

- Remove all numerics (ESC) instructions, including code that checks for the presence of the 80C187.
- Use a jumper or switch setting to indicate the presence of the 80C187. The program can interrogate the jumper or switch setting and branch away from numerics instructions when the 80C187 socket is empty.
- Trick the microprocessor into predictable operation when the 80C187 socket is empty. The fix is placing pull-up or pull-down resistors on certain data and handshaking lines so the CPU reads a recognizable Opcode Status Word. This solution requires a detailed knowledge of the interface.

Bus cycles involving the 80C187 Math Coprocessor behave exactly like other I/O bus cycles with respect to the processor's control pins. See "System Design Tips" for information on integrating the 80C187 into the overall system.

11.4.3 System Design Tips

All 80C187 operations require that bus ready be asserted. The simplest way to return the ready indication is through hardware connected to the processor's external ready pin. If you program a chip-select to cover the math coprocessor port addresses, its ready programming is in force and can provide bus ready for coprocessor accesses. The user must verify that there are no conflicts from other hardware connected to that chip-select pin.

A chip-select pin goes active on 80C187 accesses if you program it for a range including the math coprocessor I/O ports. The converse is not true — a non-80C187 access cannot activate \overline{NCS} (numerics coprocessor select), regardless of programming.

In a buffered system, it is customary to place the 80C187 on the local bus. Since \overline{DTR} and \overline{DEN} function normally during 80C187 transfers, you must qualify \overline{DEN} with \overline{NCS} (see Figure 11-3). Otherwise, contention between the 80C187 and the transceivers occurs on read cycles to the 80C187.

The microprocessor's local bus is available to the integrated peripherals during numerics execution whenever the CPU is not communicating with the 80C187. The idle bus allows the processor to intersperse DRAM refresh cycles and DMA cycles with accesses to the 80C187.

The microprocessor's local bus is available to alternate bus masters during execution of numerics instructions when the CPU does not need it. Bus cycles driven by alternate masters (via the $\overline{HOLD/HLDA}$ protocol) can suspend coprocessor bus cycles for an indefinite period.

The programmer can lock 80C187 instructions. The CPU asserts the \overline{LOCK} pin for the entire duration of a numerics instruction, monopolizing the bus for a very long time.

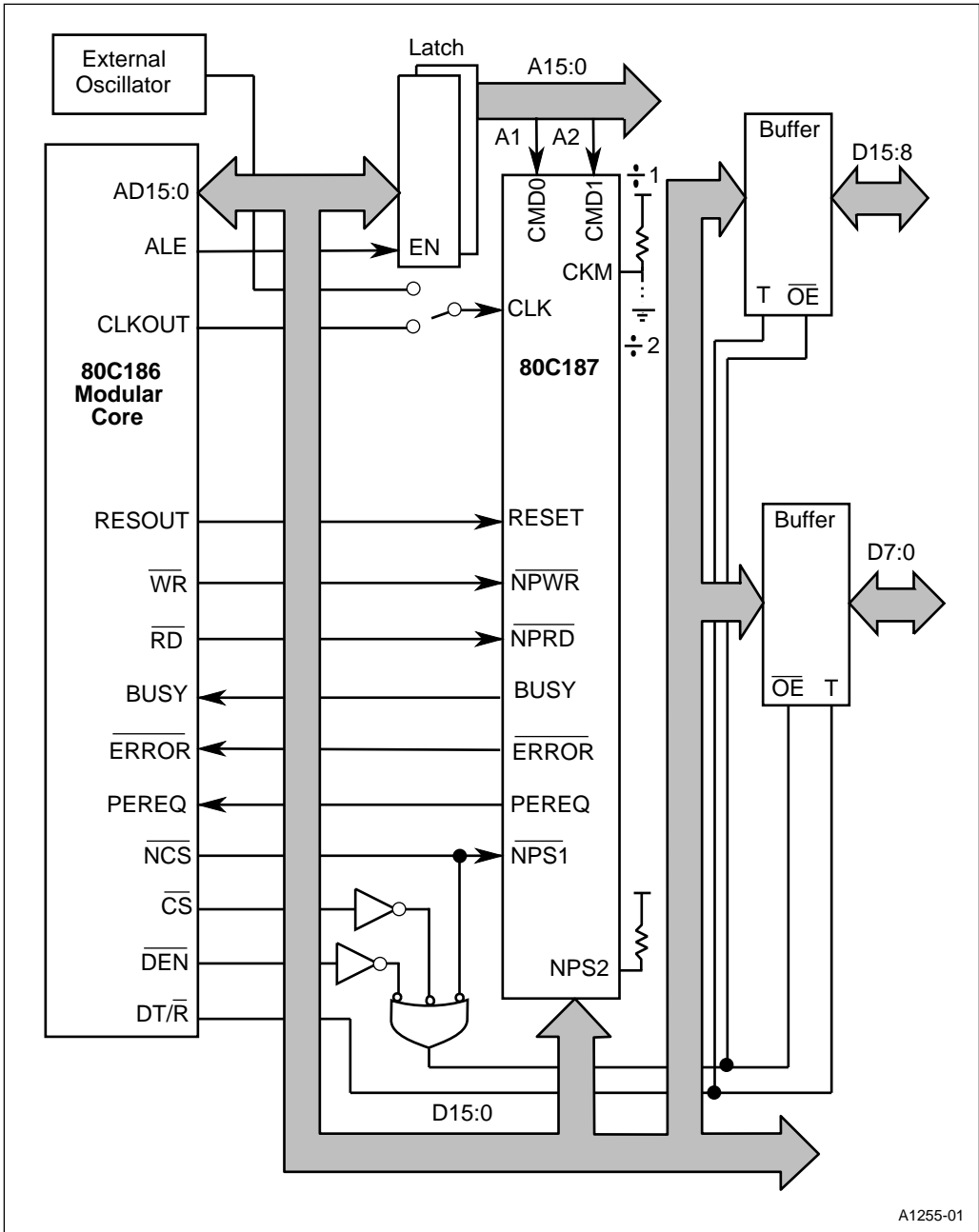

A1255-01

Figure 11-3. 80C187 Configuration with a Partially Buffered Bus

11.4.4 Exception Trapping

The 80C187 detects six error conditions that can occur during instruction execution. The 80C187 can apply default fix-ups or signal exceptions to the microprocessor's $\overline{\text{ERROR}}$ pin. The processor tests $\overline{\text{ERROR}}$ at the beginning of numerics instructions, so it traps an exception on the **next** attempted numerics instruction after it occurs. When $\overline{\text{ERROR}}$ tests active, the processor executes a Type 16 interrupt.

There is no automatic exception-trapping on the last numerics instruction of a series. If the last numerics instruction writes an invalid result to memory, subsequent non-numerics instructions can use that result as if it is valid, further compounding the original error. Insert the FNOP instruction at the end of the 80C187 routine to force an $\overline{\text{ERROR}}$ check. If the program is written in a high-level language, it is impossible to insert FNOP. In this case, route the error signal through an inverter to an interrupt pin on the microprocessor (see Figure 11-4). With this arrangement, use a flip-flop to latch BUSY upon assertion of $\overline{\text{ERROR}}$. The latch gets cleared during the exception-handler routine. Use an additional flip-flop to latch PEREQ to maintain the correct handshaking sequence with the microprocessor.

11.5 EXAMPLE MATH COPROCESSOR ROUTINES

Example 11-1 shows the initialization sequence for the 80C187. Example 11-2 is an example of a floating point routine using the 80C187. The FSINCOS instruction yields both sine and cosine in one operation.

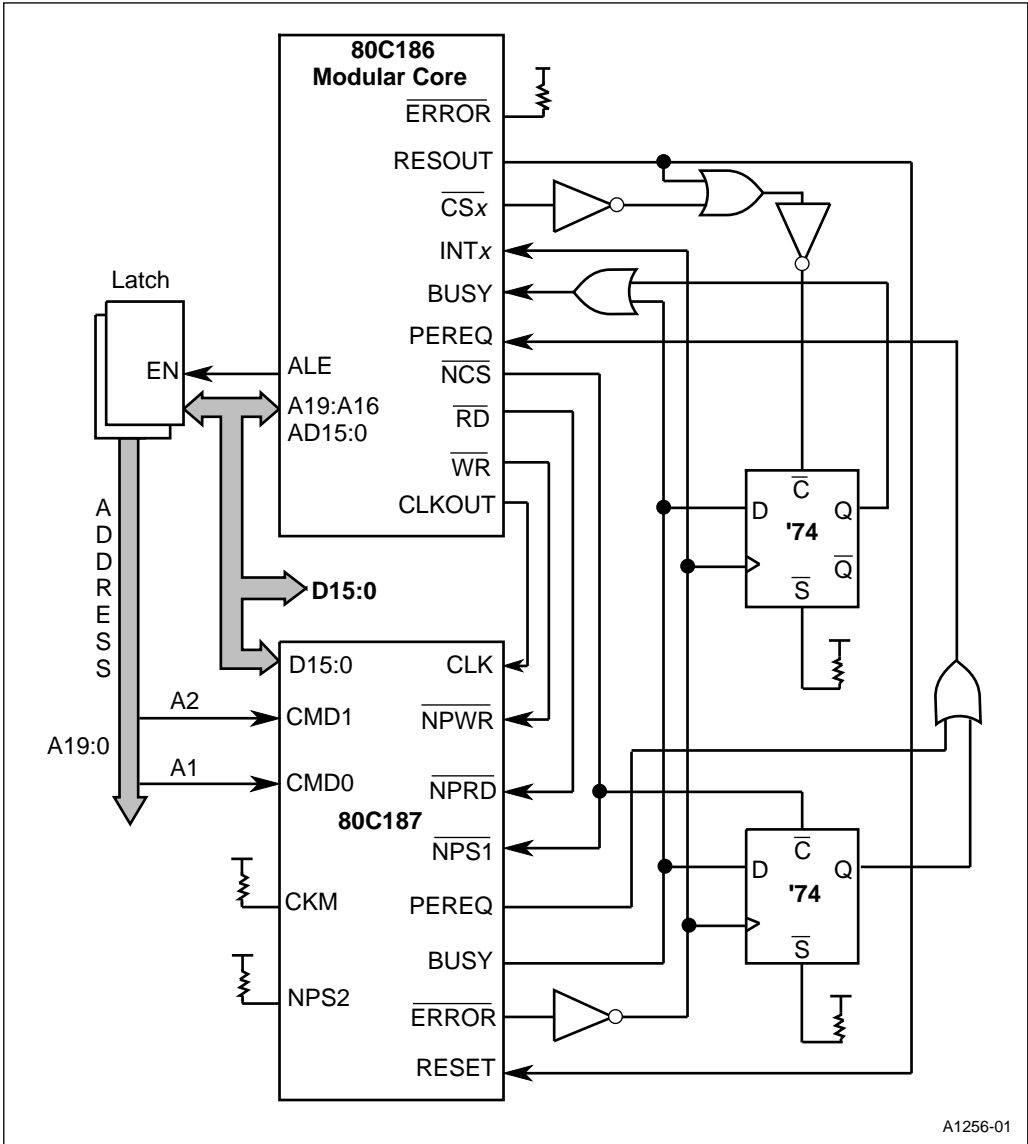

Figure 11-4. 80C187 Exception Trapping via Processor Interrupt Pin

```

$mod186
name    example_80C187_init
;
;FUNCTION:      This function initializes the 80C187 numerics coprocessor.
;
;SYNTAX:        extern unsigned char far 187_init(void);
;
;INPUTS:        None
;
;OUTPUTS:       unsigned char - 0000h -> False -> coprocessor not initialized
;               ffffh -> True -> coprocessor initialized
;
;NOTE:          Parameters are passed on the stack as required by
;               high-level languages.
;
lib_80186     segment public 'code'
               assume cs:lib_80186

               public  _187_init

_187_initproc far

               push   bp           ;save caller's bp
               mov    bp, sp       ;get current top of stack

               cli                ;disable maskable interrupts

               fninit              ;init 80C187 processor
               fnstcw [bp-2]       ;get current control word

               sti                ;enable interrupts

               mov     ax, [bp-2]
               and     ax, 0300h    ;mask off unwanted control bits
               cmp     ax, 0300h    ;PC bits = 11
               je      Ok           ;yes: processor ok
               xor     ax, ax        ;return false (80C187 not ok)
               pop     bp           ;restore caller's bp
               ret

               Ok:  and     [bp-2], 0ffffh    ;unmask possible exceptions
                   fldcw  [bp-2]

                   mov     ax,0ffffh        ;return true (80C187 ok)
                   pop     bp               ;restore caller's bp
                   ret

_187_initendp
lib_80186ends
end

```

Example 11-1. Initialization Sequence for 80C187 Math Coprocessor

```

$mod186
$modc187

name    example_80C187_proc

;DESCRIPTION:  This code section uses the 80C187 FSINCOS transcendental
;              instruction to convert the locus of a point from polar
;              to Cartesian coordinates.
;
;VARIABLES:   The variables consist of the radius, r, and the angle, theta.
;              Both are expressed as 32-bit reals and 0 <= theta <= pi/4.
;
;RESULTS:     The results of the computation are the coordinates x and y
;              expressed as 32-bit reals.
;
;NOTES:       This routine is coded for Intel ASM86. It is not set up as an
;              HLL-callable routine.
;
;              This code assumes that the 80C187 has already been initialized.
;
        assume cs:code, ds:data

        data    segment at 0100h
                r      dd x.xxxx           ;substitute real operand
                theta dd x.xxxx           ;substitute real operand
                x      dd ?
                y      dd ?
        data    ends

        code    segment at 0080h

convert    proc far
mov        ax, data
mov        ds, ax

        fld     r                ;load radius
        fld     theta            ;load angle
        fsincos          ;st=cos, st(1)=sin
        fmul    st, st(2)       ;compute x
        fstp   x                ;store to memory and pop
        fmul    y                ;compute y
        fstp   y                ;store to memory and pop

convert    endp

code      ends
end

```

Example 11-2. Floating Point Math Routine Using FSINCOS



12

ONCE Mode



CHAPTER 12

ONCE MODE

ONCE (pronounced “ahnce”) Mode provides the ability to three-state all output, bidirectional, or weakly held high/low pins except OSCOUT. To allow device operation with a crystal network, OSCOUT does not three-state.

ONCE Mode electrically isolates the device from the rest of the board logic. This isolation allows a bed-of-nails tester to drive the device pins directly for more accurate and thorough testing. An in-circuit emulation probe uses ONCE Mode to isolate a surface-mounted device from board logic and essentially “take over” operation of the board (without removing the soldered device from the board).

12.1 ENTERING/LEAVING ONCE MODE

Forcing \overline{UCS} and \overline{LCS} low while \overline{RESIN} is asserted (low) enables ONCE Mode (see Figure 12-1). Maintaining \overline{UCS} and \overline{LCS} and \overline{RESIN} low continues to keep ONCE Mode active. Returning \overline{UCS} and \overline{LCS} high exits ONCE Mode.

However, it is possible to keep ONCE Mode always active by deasserting \overline{RESIN} while keeping \overline{UCS} and \overline{LCS} low. Removing \overline{RESIN} “latches” ONCE Mode and allows \overline{UCS} and \overline{LCS} to be driven to any level. \overline{UCS} and \overline{LCS} must remain low for at least one clock beyond the time \overline{RESIN} is driven high. Asserting \overline{RESIN} exits ONCE Mode, assuming \overline{UCS} and \overline{LCS} do not also remain low (see Figure 12-1).

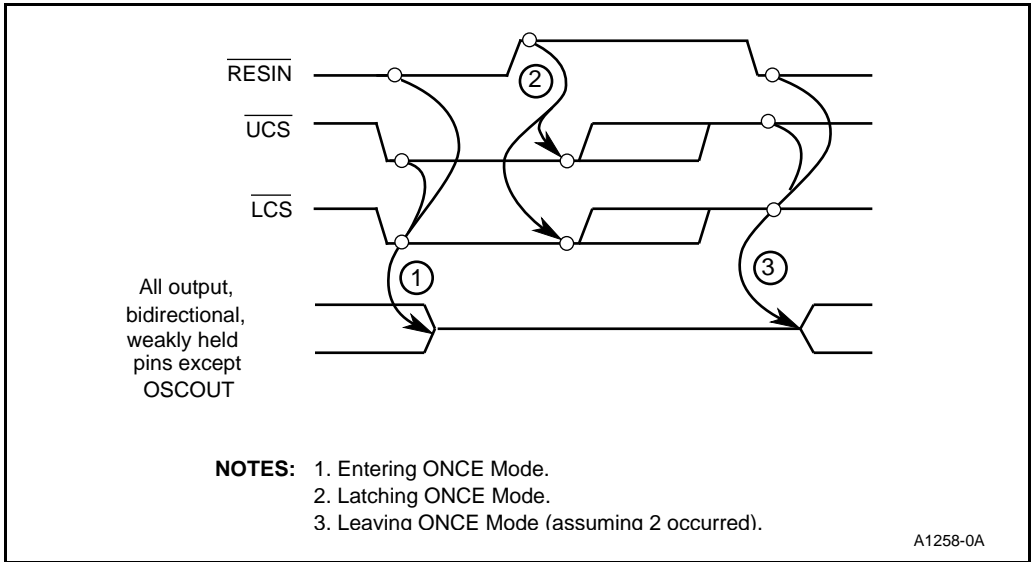

Figure 12-1. Entering/Leaving ONCE Mode



80C186 Instruction Set Additions and Extensions



APPENDIX A

80C186 INSTRUCTION SET ADDITIONS AND EXTENSIONS

The 80C186 Modular Core family instruction set differs from the original 8086/8088 instruction set in two ways. First, several instructions that were not available in the 8086/8088 instruction set have been added. Second, several 8086/8088 instructions have been enhanced for the 80C186 Modular Core family instruction set.

A.1 80C186 INSTRUCTION SET ADDITIONS

This section describes the seven instructions that were added to the base 8086/8088 instruction set to make the instruction set for the 80C186 Modular Core family. These instructions did not exist in the 8086/8088 instruction set.

- Data transfer instructions
 - PUSHA
 - POPA
- String instructions
 - INS
 - OUTS
- High-level instructions
 - ENTER
 - LEAVE
 - BOUND

A.1.1 Data Transfer Instructions

PUSHA/POPA

PUSHA (push all) and POPA (pop all) allow all general-purpose registers to be stacked and unstacked. The PUSH instruction pushes all CPU registers (except as noted below) onto the stack. The POP instruction pops all registers pushed by PUSH off of the stack. The registers are pushed onto the stack in the following order: AX, CX, DX, BX, SP, BP, SI, DI. The Stack Pointer (SP) value pushed is the Stack Pointer value before the AX register was pushed. When POP is executed, the Stack Pointer value is popped, but ignored. Note that this instruction does not save segment registers (CS, DS, SS, ES), the Instruction Pointer (IP), the Processor Status Word or any integrated peripheral registers.

A.1.2 String Instructions

INS *source_string, port*

INS (in string) performs block input from an I/O port to memory. The port address is placed in the DX register. The memory address is placed in the DI register. This instruction uses the ES segment register (which cannot be overridden). After the data transfer takes place, the pointer register (DI) increments or decrements, depending on the value of the Direction Flag (DF). The pointer register changes by one for byte transfers or by two for word transfers.

OUTS *port, destination_string*

OUTS (out string) performs block output from memory to an I/O port. The port address is placed in the DX register. The memory address is placed in the SI register. This instruction uses the DS segment register, but this may be changed with a segment override instruction. After the data transfer takes place, the pointer register (SI) increments or decrements, depending on the value of the Direction Flag (DF). The pointer register changes by one for byte transfers or by two for word transfers.

A.1.3 High-Level Instructions

ENTER *size, level*

ENTER creates the stack frame required by most block-structured high-level languages. The first parameter, *size*, specifies the number of bytes of dynamic storage to be allocated for the procedure being entered (16-bit value). The second parameter, *level*, is the lexical nesting level of the procedure (8-bit value). Note that the higher the lexical nesting level, the lower the procedure is in the nesting hierarchy.

The lexical nesting level determines the number of pointers to higher level stack frames copied into the current stack frame. This list of pointers is called the *display*. The first word of the display points to the previous stack frame. The display allows access to variables of higher level (lower lexical nesting level) procedures.

After ENTER creates a display for the current procedure, it allocates dynamic storage space. The Stack Pointer decrements by the number of bytes specified by *size*. All PUSH and POP operations in the procedure use this value of the Stack Pointer as a base.

Two forms of ENTER exist: non-nested and nested. A lexical nesting level of 0 specifies the non-nested form. In this situation, BP is pushed, then the Stack Pointer is copied to BP and decremented by the size of the frame. If the lexical nesting level is greater than 0, the nested form is used. Figure A-1 gives the formal definition of ENTER.

The following listing gives the formal definition of the ENTER instruction for all cases.

LEVEL denotes the value of the second operand.

```
Push BP
Set a temporary value FRAME_PTR: = SP
If LEVEL > 0 then
    Repeat (LEVEL - 1) times:
        BP:=BP - 2
        Push the word pointed to by BP
    End Repeat
    Push FRAME_PTR
End if
BP:=FRAME_PTR
SP:=SP - first operand
```

Figure A-1. Formal Definition of ENTER

ENTER treats a reentrant procedure as a procedure calling another procedure at the same lexical level. A reentrant procedure can address only its own variables and variables of higher-level calling procedures. ENTER ensures this by copying only stack frame pointers from higher-level procedures.

Block-structured high-level languages use lexical nesting levels to control access to variables of previously nested procedures. For example, assume for Figure A-2 that Procedure A calls Procedure B, which calls Procedure C, which calls Procedure D. Procedure C will have access to the variables of Main and Procedure A, but not to those of Procedure B because Procedures C and B operate at the same lexical nesting level.

The following is a summary of the variable access for Figure A-2.

1. Main has variables at fixed locations.
2. Procedure A can access only the fixed variables of Main.
3. Procedure B can access only the variables of Procedure A and Main.
Procedure B cannot access the variables of Procedure C or Procedure D.
4. Procedure C can access only the variables of Procedure A and Main.
Procedure C cannot access the variables of Procedure B or Procedure D.
5. Procedure D can access the variables of Procedure C, Procedure A and Main.
Procedure D cannot access the variables of Procedure B.

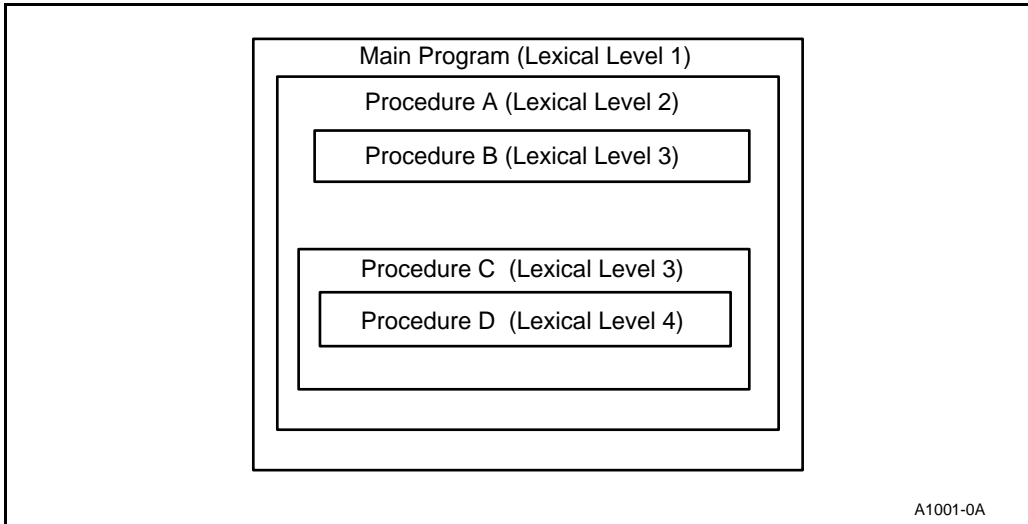

A1001-0A

Figure A-2. Variable Access in Nested Procedures

The first ENTER, executed in the Main Program, allocates dynamic storage space for Main, but no pointers are copied. The only word in the display points to itself because no previous value exists to return to after LEAVE is executed (see Figure A-3).

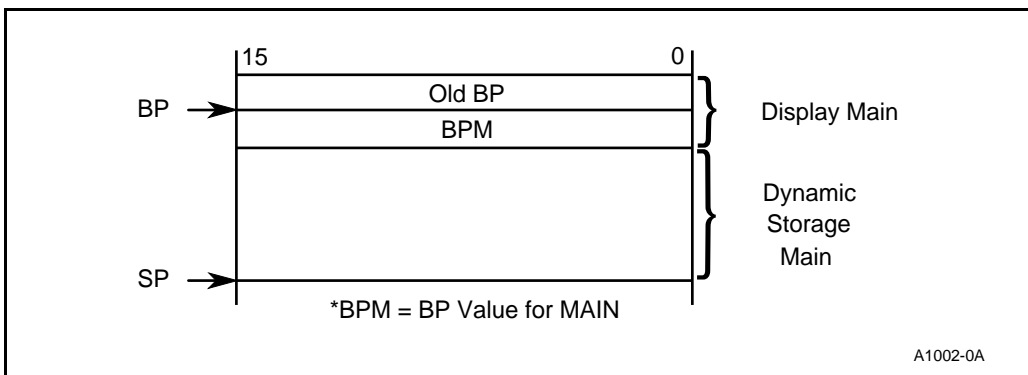

A1002-0A

Figure A-3. Stack Frame for Main at Level 1

After Main calls Procedure A, ENTER creates a new display for Procedure A. The first word points to the previous value of BP (BPM). The second word points to the current value of BP (BPA). BPM contains the base for dynamic storage in Main. All dynamic variables for Main will be at a fixed offset from this value (see Figure A-4).

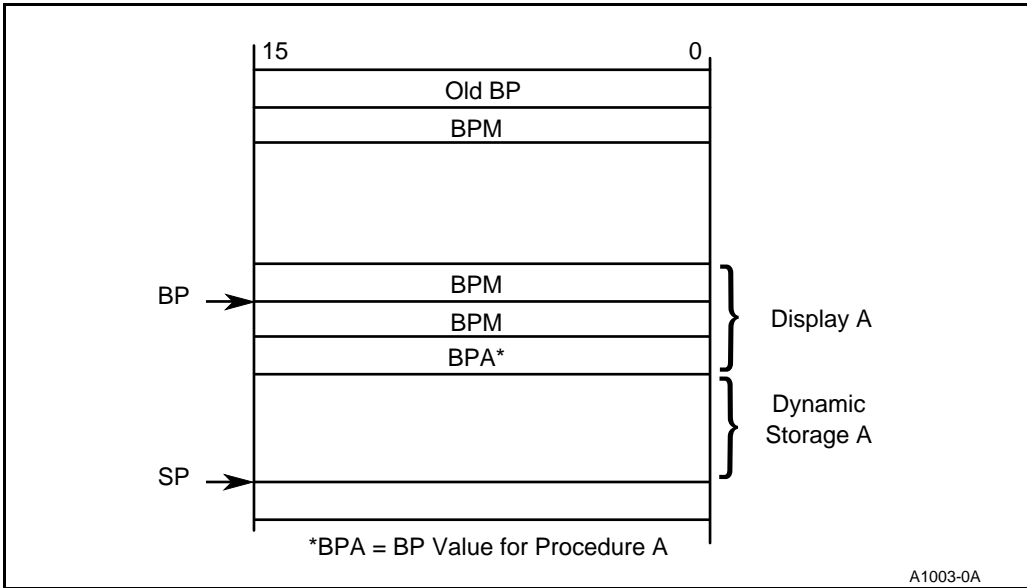

Figure A-4. Stack Frame for Procedure A at Level 2

After Procedure A calls Procedure B, ENTER creates the display for Procedure B. The first word of the display points to the previous value of BP (BPA). The second word points to the value of BP for MAIN (BPM). The third word points to the BP for Procedure A (BPA). The last word points to the current BP (BPB). Procedure B can access variables in Procedure A or Main via the appropriate BP in the display (see Figure A-5).

After Procedure B calls Procedure C, ENTER creates the display for Procedure C. The first word of the display points to the previous value of BP (BPB). The second word points to the value of BP for MAIN (BPM). The third word points to the value of BP for Procedure A (BPA). The fourth word points to the current BP (BPC). Because Procedure B and Procedure C have the same lexical nesting level, Procedure C cannot access variables in Procedure B. The only pointer to Procedure B in the display of Procedure C exists to allow the LEAVE instruction to collapse the Procedure C stack frame (see Figure A-6).

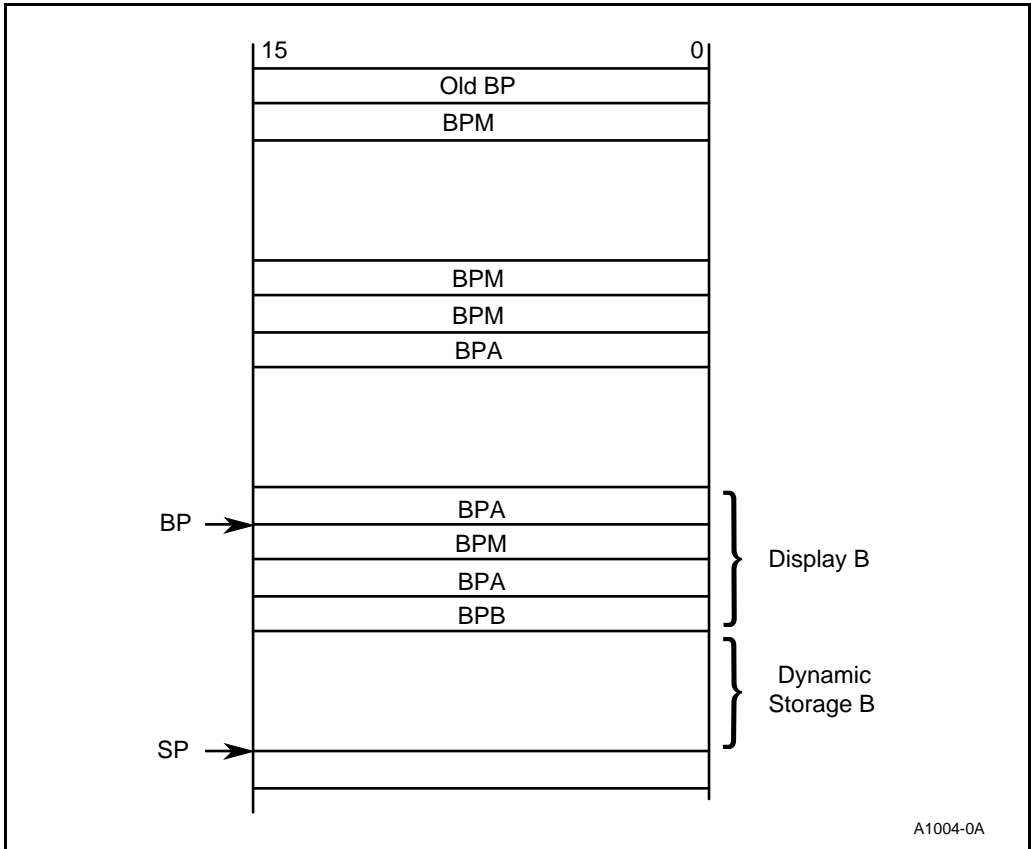

Figure A-5. Stack Frame for Procedure B at Level 3 Called from A

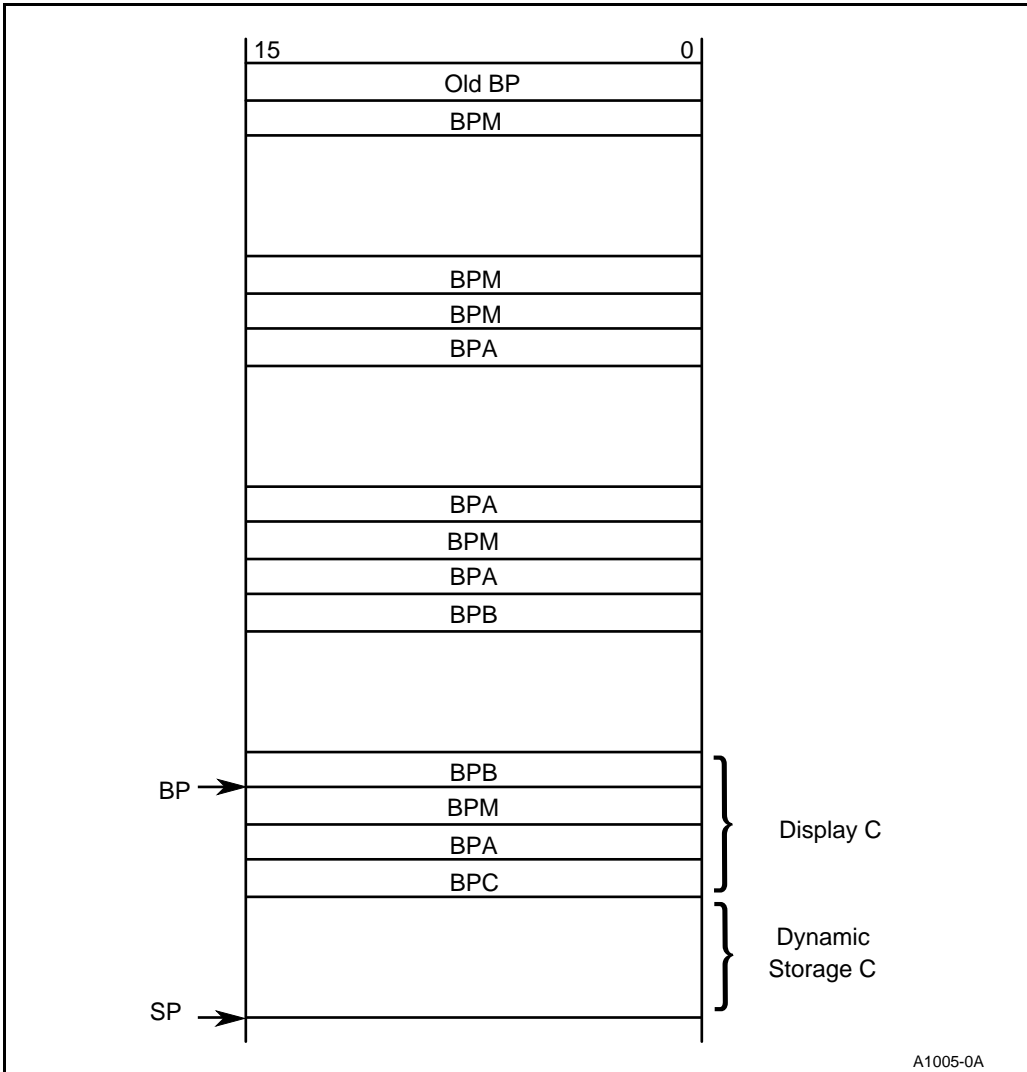

Figure A-6. Stack Frame for Procedure C at Level 3 Called from B

LEAVE

LEAVE reverses the action of the most recent ENTER instruction. It collapses the last stack frame created. First, LEAVE copies the current BP to the Stack Pointer, releasing the stack space allocated to the current procedure. Second, LEAVE pops the old value of BP from the stack, to return to the calling procedure's stack frame. A RET instruction will remove arguments stacked by the calling procedure for use by the called procedure.

BOUND *register, address*

BOUND verifies that the signed value in the specified register lies within specified limits. If the value does not lie within the bounds, an array bounds exception (type 5) occurs. BOUND is useful for checking array bounds before attempting to access an array element. This prevents the program from overwriting information outside the limits of the array.

BOUND has two operands. The first, *register*, specifies the register being tested. The second, *address*, contains the effective relative address of the two signed boundary values. The lower limit word is at this address and the upper limit word immediately follows. The limit values cannot be register operands (if they are, an invalid opcode exception occurs).

A.2 80C186 INSTRUCTION SET ENHANCEMENTS

This section describes ten instructions that were available with the 8086/8088 but have been enhanced for the 80C186 Modular Core family.

- Data transfer instructions
 - PUSH
- Arithmetic instructions
 - IMUL
- Bit manipulation instructions (shifts and rotates)
 - SAL
 - SHL
 - SAR
 - SHR
 - ROL
 - ROR
 - RCL
 - RCR

A.2.1 Data Transfer Instructions

PUSH *data*

PUSH (push immediate) allows an immediate argument, *data*, to be pushed onto the stack. The value can be either a byte or a word. Byte values are sign extended to word size before being pushed.

A.2.2 Arithmetic Instructions

IMUL *destination, source, data*

IMUL (integer immediate multiply, signed) allows a value to be multiplied by an immediate operand. IMUL requires three operands. The first, *destination*, is the register where the result will be placed. The second, *source*, is the effective address of the multiplier. The source may be the same register as the destination, another register or a memory location. The third, *data*, is an immediate value used as the multiplicand. The *data* operand may be a byte or word. If *data* is a byte, it is sign extended to 16 bits. Only the lower 16 bits of the result are saved. The result must be placed in a general-purpose register.

A.2.3 Bit Manipulation Instructions

This section describes the eight enhanced bit-manipulation instructions.

A.2.3.1 Shift Instructions

SAL *destination, count*

SAL (immediate shift arithmetic left) shifts the destination operand left by an immediate value. SAL has two operands. The first, *destination*, is the effective address to be shifted. The second, *count*, is an immediate byte value representing the number of shifts to be made. The CPU will AND *count* with 1FH before shifting, to allow no more than 32 shifts. Zeros shift in on the right.

SHL *destination, count*

SHL (immediate shift logical left) is physically the same instruction as SAL (immediate shift arithmetic left).

SAR *destination, count*

SAR (immediate shift arithmetic right) shifts the destination operand right by an immediate value. SAR has two operands. The first, *destination*, is the effective address to be shifted. The second, *count*, is an immediate byte value representing the number of shifts to be made. The CPU will AND *count* with 1FH before shifting, to allow no more than 32 shifts. The value of the original sign bit shifts into the most-significant bit to preserve the initial sign.

SHR *destination, count*

SHR (immediate shift logical right) is physically the same instruction as SAR (immediate shift arithmetic right).

A.2.3.2 Rotate Instructions

ROL *destination, count*

ROL (immediate rotate left) rotates the destination byte or word left by an immediate value. ROL has two operands. The first, *destination*, is the effective address to be rotated. The second, *count*, is an immediate byte value representing the number of rotations to be made. The most-significant bit of *destination* rotates into the least-significant bit.

ROR *destination, count*

ROR (immediate rotate right) rotates the destination byte or word right by an immediate value. ROR has two operands. The first, *destination*, is the effective address to be rotated. The second, *count*, is an immediate byte value representing the number of rotations to be made. The least-significant bit of *destination* rotates into the most-significant bit.

RCL *destination, count*

RCL (immediate rotate through carry left) rotates the destination byte or word left by an immediate value. RCL has two operands. The first, *destination*, is the effective address to be rotated. The second, *count*, is an immediate byte value representing the number of rotations to be made. The Carry Flag (CF) rotates into the least-significant bit of *destination*. The most-significant bit of *destination* rotates into the Carry Flag.

RCR *destination, count*

RCR (immediate rotate through carry right) rotates the destination byte or word right by an immediate value. RCR has two operands. The first, *destination*, is the effective address to be rotated. The second, *count*, is an immediate byte value representing the number of rotations to be made. The Carry Flag (CF) rotates into the most-significant bit of *destination*. The least-significant bit of *destination* rotates into the Carry Flag.



B

Input Synchronization



APPENDIX B INPUT SYNCHRONIZATION

Many input signals to an embedded processor are asynchronous. Asynchronous signals do not **require** a specified setup or hold time to ensure the device does not incur a failure. However, asynchronous setup and hold times are specified in the data sheet to ensure **recognition**. Associated with each of these inputs is a synchronizing circuit (see Figure B-1) that samples the asynchronous signal and synchronizes it to the internal operating clock. The output of the synchronizing circuit is then safely routed to the logic units.

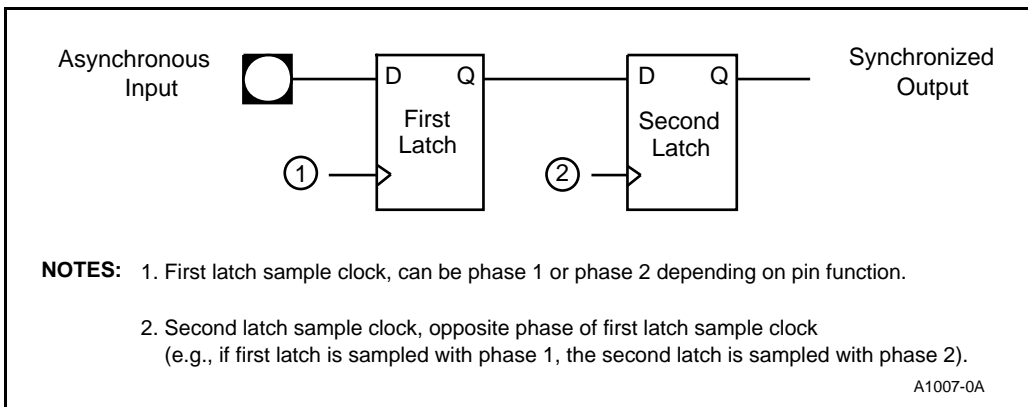

Figure B-1. Input Synchronization Circuit

B.1 WHY SYNCHRONIZERS ARE REQUIRED

Every data latch requires a specific setup and hold time to operate properly. The duration of the setup and hold time defines a *window* during which the device attempts to latch the data. If the input makes a transition within this window, the output may not attain a stable state. The data sheet specifies a setup and hold window larger than is actually required. However, variations in device operation (e.g., temperature, voltage) require that a larger window be specified to cover all conditions.

Should the input to the data latch make a transition during the sample and hold window, the output of the latch eventually attains a stable state. This stable state must be attained before the second stage of synchronization requires a valid input. To synchronize an asynchronous signal, the circuit in Figure B-1 samples the input into the first latch, allows the output to stabilize, then samples the stabilized value into a second latch. With the asynchronous signal resolved in this way, the input signal cannot cause an internal device failure.

INPUT SYNCHRONIZATION

A synchronization failure can occur when the output of the first latch does not meet the setup and hold requirements of the input of the second latch. The rate of failure is determined by the actual size of the sampling window of the data latch and by the amount of time between the strobe signals of the two latches. As the sampling window gets smaller, the number of times an asynchronous transition occurs during the sampling window drops.

B.2 ASYNCHRONOUS PINS

The 80C186EA/80C188EA inputs that use the two-stage synchronization circuit are T0IN, T1IN, NMI, $\overline{\text{TEST}}/\text{BUSY}$, INT3:0, HOLD, DRQ0 and DRQ1.



C

Instruction Set Descriptions



APPENDIX C

INSTRUCTION SET DESCRIPTIONS

This appendix provides reference information for the 80C186 Modular Core family instruction set. Tables C-1 through C-3 define the variables used in Table C-4, which lists the instructions with their descriptions and operations.

Table C-1. Instruction Format Variables

Variable	Description
dest	A register or memory location that may contain data operated on by the instruction, and which receives (is replaced by) the result of the operation.
src	A register, memory location or immediate value that is used in the operation, but is not altered by the instruction
target	A label to which control is to be transferred directly, or a register or memory location whose content is the address of the location to which control is to be transferred indirectly.
disp8	A label to which control is to be conditionally transferred; must lie within -128 to +127 bytes of the first byte of the next instruction.
accum	Register AX for word transfers, AL for bytes.
port	An I/O port number; specified as an immediate value of 0-255, or register DX (which contains port number in range 0-64K).
src-string	Name of a string in memory that is addressed by register SI; used only to identify string as byte or word and specify segment override, if any. This string is used in the operation, but is not altered.
dest-string	Name of string in memory that is addressed by register DI; used only to identify string as byte or word. This string receives (is replaced by) the result of the operation.
count	Specifies number of bits to shift or rotate; written as immediate value 1 or register CL (which contains the count in the range 0-255).
interrupt-type	Immediate value of 0-255 identifying interrupt pointer number.
optional-pop-value	Number of bytes (0-64K, ordinarily an even number) to discard from the stack.
external-opcode	Immediate value (0-63) that is encoded in the instruction for use by an external processor.

Table C-2. Instruction Operands

Operand	Description
reg	An 8- or 16-bit general register.
reg16	An 16-bit general register.
seg-reg	A segment register.
accum	Register AX or AL
immed	A constant in the range 0–FFFFH.
immed8	A constant in the range 0–FFH.
mem	An 8- or 16-bit memory location.
mem16	A 16-bit memory location.
mem32	A 32-bit memory location.
src-table	Name of 256-byte translate table.
src-string	Name of string addressed by register SI.
dest-string	Name of string addressed by register DI.
short-label	A label within the –128 to +127 bytes of the end of the instruction.
near-label	A label in current code segment.
far-label	A label in another code segment.
near-proc	A procedure in current code segment.
far-proc	A procedure in another code segment.
memptr16	A word containing the offset of the location in the current code segment to which control is to be transferred.
memptr32	A doubleword containing the offset and the segment base address of the location in another code segment to which control is to be transferred.
regptr16	A 16-bit general register containing the offset of the location in the current code segment to which control is to be transferred.
repeat	A string instruction repeat prefix.

Table C-3. Flag Bit Functions

Name	Function
AF	Auxiliary Flag: Set on carry from or borrow to the low order four bits of AL; cleared otherwise.
CF	Carry Flag: Set on high-order bit carry or borrow; cleared otherwise.
DF	Direction Flag: Causes string instructions to auto decrement the appropriate index register when set. Clearing DF causes auto increment.
IF	Interrupt-enable Flag: When set, maskable interrupts will cause the CPU to transfer control to an interrupt vector specified location.
OF	Overflow Flag: Set if the signed result cannot be expressed within the number of bits in the destination operand; cleared otherwise.
PF	Parity Flag: Set if low-order 8 bits of result contain an even number of 1 bits; cleared otherwise.
SF	Sign Flag: Set equal to high-order bit of result (0 if positive, 1 if negative).
TF	Single Step Flag: Once set, a single step interrupt occurs after the next instruction executes. TF is cleared by the single step interrupt.
ZF	Zero Flag: Set if result is zero; cleared otherwise.

Table C-4. Instruction Set

Name	Description	Operation	Flags Affected
AAA	<p>ASCII Adjust for Addition:</p> <p>AAA</p> <p>Changes the contents of register AL to a valid unpacked decimal number; the high-order half-byte is zeroed.</p> <p>Instruction Operands:</p> <p>none</p>	<p>if</p> <p>$((AL) \text{ and } 0FH) > 9$ or $(AF) = 1$</p> <p>then</p> <p>$(AL) \leftarrow (AL) + 6$</p> <p>$(AH) \leftarrow (AH) + 1$</p> <p>$(AF) \leftarrow 1$</p> <p>$(CF) \leftarrow (AF)$</p> <p>$(AL) \leftarrow (AL) \text{ and } 0FH$</p>	<p>AF ✓</p> <p>CF ✓</p> <p>DF –</p> <p>IF –</p> <p>OF ?</p> <p>PF ?</p> <p>SF ?</p> <p>TF –</p> <p>ZF ?</p>
AAD	<p>ASCII Adjust for Division:</p> <p>AAD</p> <p>Modifies the numerator in AL before dividing two valid unpacked decimal operands so that the quotient produced by the division will be a valid unpacked decimal number. AH must be zero for the subsequent DIV to produce the correct result. The quotient is returned in AL, and the remainder is returned in AH; both high-order half-bytes are zeroed.</p> <p>Instruction Operands:</p> <p>none</p>	<p>$(AL) \leftarrow (AH) \times 0AH + (AL)$</p> <p>$(AH) \leftarrow 0$</p>	<p>AF ?</p> <p>CF ?</p> <p>DF –</p> <p>IF –</p> <p>OF ?</p> <p>PF ✓</p> <p>SF ✓</p> <p>TF –</p> <p>ZF ✓</p>
AAM	<p>ASCII Adjust for Multiply:</p> <p>AAM</p> <p>Corrects the result of a previous multiplication of two valid unpacked decimal operands. A valid 2-digit unpacked decimal number is derived from the content of AH and AL and is returned to AH and AL. The high-order half-bytes of the multiplied operands must have been 0H for AAM to produce a correct result.</p> <p>Instruction Operands:</p> <p>none</p>	<p>$(AH) \leftarrow (AL) / 0AH$</p> <p>$(AL) \leftarrow (AL) \% 0AH$</p>	<p>AF ?</p> <p>CF ?</p> <p>DF –</p> <p>IF –</p> <p>OF ?</p> <p>PF ✓</p> <p>SF ✓</p> <p>TF –</p> <p>ZF ✓</p>

NOTE: The three symbols used in the Flags Affected column are defined as follows:

- the contents of the flag remain unchanged after the instruction is executed
- ? the contents of the flag is undefined after the instruction is executed
- ✓ the flag is updated after the instruction is executed

Table C-4. Instruction Set (Continued)

Name	Description	Operation	Flags Affected
AAS	<p>ASCII Adjust for Subtraction:</p> <p>AAS</p> <p>Corrects the result of a previous subtraction of two valid unpacked decimal operands (the destination operand must have been specified as register AL). Changes the content of AL to a valid unpacked decimal number; the high-order half-byte is zeroed.</p> <p>Instruction Operands:</p> <p>none</p>	<p>if ((AL) and 0FH) > 9 or (AF) = 1 then (AL) ← (AL) – 6 (AH) ← (AH) – 1 (AF) ← 1 (CF) ← (AF) (AL) ← (AL) and 0FH</p>	<p>AF ✓ CF ✓ DF – IF – OF ? PF ? SF ? TF – ZF ?</p>
ADC	<p>Add with Carry:</p> <p>ADC <i>dest, src</i></p> <p>Sums the operands, which may be bytes or words, adds one if CF is set and replaces the destination operand with the result. Both operands may be signed or unsigned binary numbers (see AAA and DAA). Since ADC incorporates a carry from a previous operation, it can be used to write routines to add numbers longer than 16 bits.</p> <p>Instruction Operands:</p> <p>ADC reg, reg ADC reg, mem ADC mem, reg ADC reg, imm ADC mem, imm ADC accum, imm</p>	<p>if (CF) = 1 then (dest) ← (dest) + (src) + 1 else (dest) ← (dest) + (src)</p>	<p>AF ✓ CF ✓ DF – IF – OF ✓ PF ✓ SF ✓ TF – ZF ✓</p>

NOTE: The three symbols used in the Flags Affected column are defined as follows:
 – the contents of the flag remain unchanged after the instruction is executed
 ? the contents of the flag is undefined after the instruction is executed
 ✓ the flag is updated after the instruction is executed

Table C-4. Instruction Set (Continued)

Name	Description	Operation	Flags Affected
ADD	<p>Addition:</p> <p>ADD <i>dest, src</i></p> <p>Sums two operands, which may be bytes or words, replaces the destination operand. Both operands may be signed or unsigned binary numbers (see AAA and DAA).</p> <p>Instruction Operands:</p> <p>ADD reg, reg ADD reg, mem ADD mem, reg ADD reg, immed ADD mem, immed ADD accum, immed</p>	$(dest) \leftarrow (dest) + (src)$	AF ✓ CF ✓ DF – IF – OF ✓ PF ✓ SF ✓ TF – ZF ✓
AND	<p>And Logical:</p> <p>AND <i>dest, src</i></p> <p>Performs the logical "and" of the two operands (byte or word) and returns the result to the destination operand. A bit in the result is set if both corresponding bits of the original operands are set; otherwise the bit is cleared.</p> <p>Instruction Operands:</p> <p>AND reg, reg AND reg, mem AND mem, reg AND reg, immed AND mem, immed AND accum, immed</p>	$(dest) \leftarrow (dest) \text{ and } (src)$ $(CF) \leftarrow 0$ $(OF) \leftarrow 0$	AF ? CF ✓ DF – IF – OF ✓ PF ✓ SF ✓ TF – ZF ✓

NOTE: The three symbols used in the Flags Affected column are defined as follows:
– the contents of the flag remain unchanged after the instruction is executed
? the contents of the flag is undefined after the instruction is executed
✓ the flag is updated after the instruction is executed

Table C-4. Instruction Set (Continued)

Name	Description	Operation	Flags Affected
BOUND	<p>Detect Value Out of Range:</p> <p>BOUND <i>dest, src</i></p> <p>Provides array bounds checking in hardware. The calculated array index is placed in one of the general purpose registers, and the upper and lower bounds of the array are placed in two consecutive memory locations. The contents of the register are compared with the memory location values, and if the register value is less than the first location or greater than the second memory location, a trap type 5 is generated.</p> <p>Instruction Operands:</p> <p>BOUND reg, mem</p>	<p>if $((dest) < (src) \text{ or } (dest) > ((src) + 2))$ then $(SP) \leftarrow (SP) - 2$ $((SP) + 1 : (SP)) \leftarrow \text{FLAGS}$ $(IF) \leftarrow 0$ $(TF) \leftarrow 0$ $(SP) \leftarrow (SP) - 2$ $((SP) + 1 : (SP)) \leftarrow (CS)$ $(CS) \leftarrow (1EH)$ $(SP) \leftarrow (SP) - 2$ $((SP) + 1 : (SP)) \leftarrow (IP)$ $(IP) \leftarrow (1CH)$</p>	<p>AF – CF – DF – IF – OF – PF – SF – TF – ZF –</p>
CALL	<p>Call Procedure:</p> <p>CALL <i>procedure-name</i></p> <p>Activates an out-of-line procedure, saving information on the stack to permit a RET (return) instruction in the procedure to transfer control back to the instruction following the CALL. The assembler generates a different type of CALL instruction depending on whether the programmer has defined the procedure name as NEAR or FAR.</p> <p>Instruction Operands:</p> <p>CALL near-proc CALL far-proc CALL memptr16 CALL regptr16 CALL memptr32</p>	<p>if Inter-segment then $(SP) \leftarrow (SP) - 2$ $((SP) + 1 : (SP)) \leftarrow (CS)$ $(CS) \leftarrow \text{SEG}$ $(SP) \leftarrow (SP) - 2$ $((SP) + 1 : (SP)) \leftarrow (IP)$ $(IP) \leftarrow \text{dest}$</p>	<p>AF – CF – DF – IF – OF – PF – SF – TF – ZF –</p>

NOTE: The three symbols used in the Flags Affected column are defined as follows:
– the contents of the flag remain unchanged after the instruction is executed
? the contents of the flag is undefined after the instruction is executed
✓ the flag is updated after the instruction is executed

Table C-4. Instruction Set (Continued)

Name	Description	Operation	Flags Affected
CBW	<p>Convert Byte to Word:</p> <p>CBW</p> <p>Extends the sign of the byte in register AL throughout register AH. Use to produce a double-length (word) dividend from a byte prior to performing byte division.</p> <p>Instruction Operands:</p> <p>none</p>	<p>if</p> <p>(AL) < 80H</p> <p>then</p> <p>(AH) ← 0</p> <p>else</p> <p>(AH) ← FFH</p>	<p>AF –</p> <p>CF –</p> <p>DF –</p> <p>IF –</p> <p>OF –</p> <p>PF –</p> <p>SF –</p> <p>TF –</p> <p>ZF –</p>
CLC	<p>Clear Carry flag:</p> <p>CLC</p> <p>Zeroes the carry flag (CF) and affects no other flags. Useful in conjunction with the rotate through carry left (RCL) and the rotate through carry right (RCR) instructions.</p> <p>Instruction Operands:</p> <p>none</p>	(CF) ← 0	<p>AF –</p> <p>CF ✓</p> <p>DF –</p> <p>IF –</p> <p>OF –</p> <p>PF –</p> <p>SF –</p> <p>TF –</p> <p>ZF –</p>
CLD	<p>Clear Direction flag:</p> <p>CLD</p> <p>Zeroes the direction flag (DF) causing the string instructions to auto-increment the source index (SI) and/or destination index (DI) registers.</p> <p>Instruction Operands:</p> <p>none</p>	(DF) ← 0	<p>AF –</p> <p>CF –</p> <p>DF ✓</p> <p>IF –</p> <p>OF –</p> <p>PF –</p> <p>SF –</p> <p>TF –</p> <p>ZF –</p>

NOTE: The three symbols used in the Flags Affected column are defined as follows:

- the contents of the flag remain unchanged after the instruction is executed
- ? the contents of the flag is undefined after the instruction is executed
- ✓ the flag is updated after the instruction is executed

Table C-4. Instruction Set (Continued)

Name	Description	Operation	Flags Affected
CLI	<p>Clear Interrupt-enable Flag:</p> <p>CLI</p> <p>Zeroes the interrupt-enable flag (IF). When the interrupt-enable flag is cleared, the 8086 and 8088 do not recognize an external interrupt request that appears on the INTR line; in other words maskable interrupts are disabled. A non-maskable interrupt appearing on NMI line, however, is honored, as is a software interrupt.</p> <p>Instruction Operands:</p> <p>none</p>	(IF) ← 0	<p>AF –</p> <p>CF –</p> <p>DF –</p> <p>IF ✓</p> <p>OF –</p> <p>PF –</p> <p>SF –</p> <p>TF –</p> <p>ZF –</p>
CMC	<p>Complement Carry Flag:</p> <p>CMC</p> <p>Toggles complement carry flag (CF) to its opposite state and affects no other flags.</p> <p>Instruction Operands:</p> <p>none</p>	<p>if</p> <p>(CF) = 0</p> <p>then</p> <p>(CF) ← 1</p> <p>else</p> <p>(CF) ← 0</p>	<p>AF –</p> <p>CF ✓</p> <p>DF –</p> <p>IF –</p> <p>OF –</p> <p>PF –</p> <p>SF –</p> <p>TF –</p> <p>ZF –</p>

NOTE: The three symbols used in the Flags Affected column are defined as follows:

- the contents of the flag remain unchanged after the instruction is executed
- ? the contents of the flag is undefined after the instruction is executed
- ✓ the flag is updated after the instruction is executed

Table C-4. Instruction Set (Continued)

Name	Description	Operation	Flags Affected
CMP	<p>Compare:</p> <p>CMP <i>dest, src</i></p> <p>Subtracts the source from the destination, which may be bytes or words, but does not return the result. The operands are unchanged, but the flags are updated and can be tested by a subsequent conditional jump instruction. The comparison reflected in the flags is that of the destination to the source. If a CMP instruction is followed by a JG (jump if greater) instruction, for example, the jump is taken if the destination operand is greater than the source operand.</p> <p>Instruction Operands:</p> <p>CMP reg, reg CMP reg, mem CMP mem, reg CMP reg, immed CMP mem, immed CMP accum, immed</p>	(dest) – (src)	AF ✓ CF ✓ DF – IF – OF ✓ PF ✓ SF ✓ TF – ZF ✓
CMPS	<p>Compare String:</p> <p>CMPS <i>dest-string, src-string</i></p> <p>Subtracts the destination byte or word from the source byte or word. The destination byte or word is addressed by the destination index (DI) register and the source byte or word is addresses by the source index (SI) register. CMPS updates the flags to reflect the relationship of the destination element to the source element but does not alter either operand and updates SI and DI to point to the next string element.</p> <p>Instruction Operands:</p> <p>CMP dest-string, src-string CMP (repeat) dest-string, src-string</p>	(dest-string) – (src-string) if (DI) = 0 then (SI) ← (SI) + DELTA (DI) ← (DI) + DELTA else (SI) ← (SI) – DELTA (DI) ← (DI) – DELTA	AF ✓ CF ✓ DF – IF – OF ✓ PF ✓ SF ✓ TF – ZF ✓

NOTE: The three symbols used in the Flags Affected column are defined as follows:
 – the contents of the flag remain unchanged after the instruction is executed
 ? the contents of the flag is undefined after the instruction is executed
 ✓ the flag is updated after the instruction is executed

Table C-4. Instruction Set (Continued)

Name	Description	Operation	Flags Affected
CWD	<p>Convert Word to Doubleword:</p> <p>CWD</p> <p>Extends the sign of the word in register AX throughout register DX. Use to produce a double-length (doubleword) dividend from a word prior to performing word division.</p> <p>Instruction Operands:</p> <p>none</p>	<p>if $(AX) < 8000H$ then $(DX) \leftarrow 0$ else $(DX) \leftarrow FFFFH$</p>	<p>AF – CF – DF – IF – OF – PF – SF – TF – ZF –</p>
DAA	<p>Decimal Adjust for Addition:</p> <p>DAA</p> <p>Corrects the result of previously adding two valid packed decimal operands (the destination operand must have been register AL). Changes the content of AL to a pair of valid packed decimal digits.</p> <p>Instruction Operands:</p> <p>none</p>	<p>if $((AL) \text{ and } 0FH) > 9 \text{ or } (AF) = 1$ then $(AL) \leftarrow (AL) + 6$ $(AF) \leftarrow 1$ if $(AL) > 9FH \text{ or } (CF) = 1$ then $(AL) \leftarrow (AL) + 60H$ $(CF) \leftarrow 1$</p>	<p>AF ✓ CF ✓ DF – IF – OF ? PF ✓ SF ✓ TF – ZF ✓</p>
DAS	<p>Decimal Adjust for Subtraction:</p> <p>DAS</p> <p>Corrects the result of a previous subtraction of two valid packed decimal operands (the destination operand must have been specified as register AL). Changes the content of AL to a pair of valid packed decimal digits.</p> <p>Instruction Operands:</p> <p>none</p>	<p>if $((AL) \text{ and } 0FH) > 9 \text{ or } (AF) = 1$ then $(AL) \leftarrow (AL) - 6$ $(AF) \leftarrow 1$ if $(AL) > 9FH \text{ or } (CF) = 1$ then $(AL) \leftarrow (AL) - 60H$ $(CF) \leftarrow 1$</p>	<p>AF ✓ CF ✓ DF – IF – OF ? PF ✓ SF ✓ TF – ZF ✓</p>

NOTE: The three symbols used in the Flags Affected column are defined as follows:
– the contents of the flag remain unchanged after the instruction is executed
? the contents of the flag is undefined after the instruction is executed
✓ the flag is updated after the instruction is executed

Table C-4. Instruction Set (Continued)

Name	Description	Operation	Flags Affected
DEC	<p>Decrement: DEC <i>dest</i></p> <p>Subtracts one from the destination operand. The operand may be a byte or a word and is treated as an unsigned binary number (see AAA and DAA).</p> <p>Instruction Operands: DEC reg DEC mem</p>	$(dest) \leftarrow (dest) - 1$	AF ✓ CF – DF – IF – OF ✓ PF ✓ SF ✓ TF – ZF ✓

NOTE: The three symbols used in the Flags Affected column are defined as follows:
 – the contents of the flag remain unchanged after the instruction is executed
 ? the contents of the flag is undefined after the instruction is executed
 ✓ the flag is updated after the instruction is executed

Table C-4. Instruction Set (Continued)

Name	Description	Operation	Flags Affected
DIV	<p>Divide:</p> <p>DIV <i>src</i></p> <p>Performs an unsigned division of the accumulator (and its extension) by the source operand.</p> <p>If the source operand is a byte, it is divided into the two-byte dividend assumed to be in registers AL and AH. The byte quotient is returned in AL, and the byte remainder is returned in AH.</p> <p>If the source operand is a word, it is divided into the two-word dividend in registers AX and DX. The word quotient is returned in AX, and the word remainder is returned in DX.</p> <p>If the quotient exceeds the capacity of its destination register (FFH for byte source, FFFFH for word source), as when division by zero is attempted, a type 0 interrupt is generated, and the quotient and remainder are undefined. Nonintegral quotients are truncated to integers.</p> <p>Instruction Operands:</p> <p>DIV reg DIV mem</p>	<p>When Source Operand is a Byte:</p> <p>(temp) ← (byte-src) if (temp) / (AX) > FFH then (type 0 interrupt is generated) (SP) ← (SP) – 2 ((SP) + 1:(SP)) ← FLAGS (IF) ← 0 (TF) ← 0 (SP) ← (SP) – 2 ((SP) + 1:(SP)) ← (CS) (CS) ← (2) (SP) ← (SP) – 2 ((SP) + 1:(SP)) ← (IP) (IP) ← (0) else (AL) ← (temp) / (AX) (AH) ← (temp) % (AX)</p> <p>When Source Operand is a Word:</p> <p>(temp) ← (word-src) if (temp) / (DX:AX) > FFFFH then (type 0 interrupt is generated) (SP) ← (SP) – 2 ((SP) + 1:(SP)) ← FLAGS (IF) ← 0 (TF) ← 0 (SP) ← (SP) – 2 ((SP) + 1:(SP)) ← (CS) (CS) ← (2) (SP) ← (SP) – 2 ((SP) + 1:(SP)) ← (IP) (IP) ← (0) else (AX) ← (temp) / (DX:AX) (DX) ← (temp) % (DX:AX)</p>	<p>AF ? CF ? DF – IF – OF ? PF ? SF ? TF – ZF ?</p>

NOTE: The three symbols used in the Flags Affected column are defined as follows:
 – the contents of the flag remain unchanged after the instruction is executed
 ? the contents of the flag is undefined after the instruction is executed
 ✓ the flag is updated after the instruction is executed

Table C-4. Instruction Set (Continued)

Name	Description	Operation	Flags Affected
ENTER	<p>Procedure Entry: ENTER <i>locals, levels</i></p> <p>Executes the calling sequence for a high-level language. It saves the current frame pointer in BP, copies the frame pointers from procedures below the current call (to allow access to local variables in these procedures) and allocates space on the stack for the local variables of the current procedure invocation.</p> <p>Instruction Operands: ENTER <i>locals, level</i></p>	$(SP) \leftarrow (SP) - 2$ $((SP) + 1:(SP)) \leftarrow (BP)$ $(FP) \leftarrow (SP)$ if $level > 0$ then repeat $(level - 1)$ times $(BP) \leftarrow (BP) - 2$ $(SP) \leftarrow (SP) - 2$ $((SP) + 1:(SP)) \leftarrow (BP)$ end repeat $(SP) \leftarrow (SP) - 2$ $((SP) + 1:(SP)) \leftarrow (FP)$ end if $(BP) \leftarrow (FP)$ $(SP) \leftarrow (SP) - (locals)$	AF – CF – DF – IF – OF – PF – SF – TF – ZF –
ESC	<p>Escape: ESC</p> <p>Provides a mechanism by which other processors (coprocessors) may receive their instructions from the 8086 or 8088 instruction stream and make use of the 8086 or 8088 addressing modes. The CPU (8086 or 8088) does a no operation (NOP) for the ESC instruction other than to access a memory operand and place it on the bus.</p> <p>Instruction Operands: ESC <i>immed, mem</i> ESC <i>immed, reg</i></p>	if $mod \neq 11$ then $data\ bus \leftarrow (EA)$	AF – CF – DF – IF – OF – PF – SF – TF – ZF –

NOTE: The three symbols used in the Flags Affected column are defined as follows:
– the contents of the flag remain unchanged after the instruction is executed
? the contents of the flag is undefined after the instruction is executed
✓ the flag is updated after the instruction is executed

Table C-4. Instruction Set (Continued)

Name	Description	Operation	Flags Affected
HLT	<p>Halt: HLT</p> <p>Causes the CPU to enter the halt state. The processor leaves the halt state upon activation of the RESET line, upon receipt of a non-maskable interrupt request on NMI, or upon receipt of a maskable interrupt request on INTR (if interrupts are enabled).</p> <p>Instruction Operands: none</p>	None	AF – CF – DF – IF – OF – PF – SF – TF – ZF –

NOTE: The three symbols used in the Flags Affected column are defined as follows:

- the contents of the flag remain unchanged after the instruction is executed
- ? the contents of the flag is undefined after the instruction is executed
- ✓ the flag is updated after the instruction is executed

Table C-4. Instruction Set (Continued)

Name	Description	Operation	Flags Affected
IDIV	<p>Integer Divide:</p> <p>IDIV <i>src</i></p> <p>Performs a signed division of the accumulator (and its extension) by the source operand. If the source operand is a byte, it is divided into the double-length dividend assumed to be in registers AL and AH; the single-length quotient is returned in AL, and the single-length remainder is returned in AH. For byte integer division, the maximum positive quotient is +127 (7FH) and the minimum negative quotient is -127 (81H).</p> <p>If the source operand is a word, it is divided into the double-length dividend in registers AX and DX; the single-length quotient is returned in AX, and the single-length remainder is returned in DX. For word integer division, the maximum positive quotient is +32,767 (7FFFH) and the minimum negative quotient is -32,767 (8001H).</p> <p>If the quotient is positive and exceeds the maximum, or is negative and is less than the minimum, the quotient and remainder are undefined, and a type 0 interrupt is generated. In particular, this occurs if division by 0 is attempted. Nonintegral quotients are truncated (toward 0) to integers, and the remainder has the same sign as the dividend.</p> <p>Instruction Operands:</p> <p>IDIV reg IDIV mem</p>	<p>When Source Operand is a Byte:</p> <p>(temp) ← (byte-src) if (temp) / (AX) > 0 and (temp) / (AX) > 7FH or (temp) / (AX) < 0 and (temp) / (AX) < 0 - 7FH - 1 then (type 0 interrupt is generated) (SP) ← (SP) - 2 ((SP) + 1:(SP)) ← FLAGS (IF) ← 0 (TF) ← 0 (SP) ← (SP) - 2 ((SP) + 1:(SP)) ← (CS) (CS) ← (2) (SP) ← (SP) - 2 ((SP) + 1:(SP)) ← (IP) (IP) ← (0) else (AL) ← (temp) / (AX) (AH) ← (temp) % (AX)</p> <p>When Source Operand is a Word:</p> <p>(temp) ← (word-src) if (temp) / (DX:AX) > 0 and (temp) / (DX:AX) > 7FFFH or (temp) / (DX:AX) < 0 and (temp) / (DX:AX) < 0 - 7FFFH - 1 then (type 0 interrupt is generated) (SP) ← (SP) - 2 ((SP) + 1:(SP)) ← FLAGS (IF) ← 0 (TF) ← 0 (SP) ← (SP) - 2 ((SP) + 1:(SP)) ← (CS) (CS) ← (2) (SP) ← (SP) - 2 ((SP) + 1:(SP)) ← (IP) (IP) ← (0) else (AX) ← (temp) / (DX:AX) (DX) ← (temp) % (DX:AX)</p>	<p>AF ? CF ? DF – IF – OF ? PF ? SF ? TF – ZF ?</p>

NOTE: The three symbols used in the Flags Affected column are defined as follows:
– the contents of the flag remain unchanged after the instruction is executed
? the contents of the flag is undefined after the instruction is executed
✓ the flag is updated after the instruction is executed

Table C-4. Instruction Set (Continued)

Name	Description	Operation	Flags Affected
IMUL	<p>Integer Multiply:</p> <p>IMUL <i>src</i></p> <p>Performs a signed multiplication of the source operand and the accumulator. If the source is a byte, then it is multiplied by register AL, and the double-length result is returned in AH and AL. If the source is a word, then it is multiplied by register AX, and the double-length result is returned in registers DX and AX. If the upper half of the result (AH for byte source, DX for word source) is not the sign extension of the lower half of the result, CF and OF are set; otherwise they are cleared. When CF and OF are set, they indicate that AH or DX contains significant digits of the result.</p> <p>Instruction Operands:</p> <p>IMUL reg IMUL mem IMUL immed</p>	<p>When Source Operand is a Byte:</p> <p>$(AX) \leftarrow (\text{byte-src}) \times (AL)$</p> <p>if $(AH) = \text{sign-extension of } (AL)$ then $(CF) \leftarrow 0$ else $(CF) \leftarrow 1$ $(OF) \leftarrow (CF)$</p> <p>When Source Operand is a Word:</p> <p>$(DX:AX) \leftarrow (\text{word-src}) \times (AX)$</p> <p>if $(DX) = \text{sign-extension of } (AX)$ then $(CF) \leftarrow 0$ else $(CF) \leftarrow 1$ $(OF) \leftarrow (CF)$</p>	AF ? CF ✓ DF – IF – OF ✓ PF ? SF ? TF – ZF ?
IN	<p>Input Byte or Word:</p> <p>IN <i>accum, port</i></p> <p>Transfers a byte or a word from an input port to the AL register or the AX register, respectively. The port number may be specified either with an immediate byte constant, allowing access to ports numbered 0 through 255, or with a number previously placed in the DX register, allowing variable access (by changing the value in DX) to ports numbered from 0 through 65,535.</p> <p>Instruction Operands:</p> <p>IN AL, immed8 IN AX, DX</p>	<p>When Source Operand is a Byte:</p> <p>$(AL) \leftarrow (\text{port})$</p> <p>When Source Operand is a Word:</p> <p>$(AX) \leftarrow (\text{port})$</p>	AF – CF – DF – IF – OF – PF – SF – TF – ZF –

NOTE: The three symbols used in the Flags Affected column are defined as follows:
 – the contents of the flag remain unchanged after the instruction is executed
 ? the contents of the flag is undefined after the instruction is executed
 ✓ the flag is updated after the instruction is executed

Table C-4. Instruction Set (Continued)

Name	Description	Operation	Flags Affected
INC	<p>Increment: INC <i>dest</i></p> <p>Adds one to the destination operand. The operand may be byte or a word and is treated as an unsigned binary number (see AAA and DAA).</p> <p>Instruction Operands: INC reg INC mem</p>	$(dest) \leftarrow (dest) + 1$	AF ✓ CF – DF – IF – OF ✓ PF ✓ SF ✓ TF – ZF ✓
INS	<p>In String: INS <i>dest-string, port</i></p> <p>Performs block input from an I/O port to memory. The port address is placed in the DX register. The memory address is placed in the DI register. This instruction uses the ES register (which cannot be overridden). After the data transfer takes place, the DI register increments or decrements, depending on the value of the direction flag (DF). The DI register changes by 1 for byte transfers or 2 for word transfers.</p> <p>Instruction Operands: INS <i>dest-string, port</i> INS (repeat) <i>dest-string, port</i></p>	$(dest) \leftarrow (src)$	AF – CF – DF – IF – OF – PF – SF – TF – ZF –

NOTE: The three symbols used in the Flags Affected column are defined as follows:
 – the contents of the flag remain unchanged after the instruction is executed
 ? the contents of the flag is undefined after the instruction is executed
 ✓ the flag is updated after the instruction is executed

Table C-4. Instruction Set (Continued)

Name	Description	Operation	Flags Affected
INT	<p>Interrupt:</p> <p>INT <i>interrupt-type</i></p> <p>Activates the interrupt procedure specified by the interrupt-type operand. Decrements the stack pointer by two, pushes the flags onto the stack, and clears the trap (TF) and interrupt-enable (IF) flags to disable single-step and maskable interrupts. The flags are stored in the format used by the PUSHF instruction. SP is decremented again by two, and the CS register is pushed onto the stack.</p> <p>The address of the interrupt pointer is calculated by multiplying interrupt-type by four; the second word of the interrupt pointer replaces CS. SP again is decremented by two, and IP is pushed onto the stack and is replaced by the first word of the interrupt pointer. If interrupt-type = 3, the assembler generates a short (1 byte) form of the instruction, known as the breakpoint interrupt.</p> <p>Instruction Operands:</p> <p>INT immed8</p>	$(SP) \leftarrow (SP) - 2$ $((SP) + 1:(SP)) \leftarrow \text{FLAGS}$ $(IF) \leftarrow 0$ $(TF) \leftarrow 0$ $(SP) \leftarrow (SP) - 2$ $((SP) + 1:(SP)) \leftarrow (CS)$ $(CS) \leftarrow (\text{interrupt-type} \times 4 + 2)$ $(SP) \leftarrow (SP) - 2$ $((SP) + 1:(SP)) \leftarrow (IP)$ $(IP) \leftarrow (\text{interrupt-type} \times 4)$	<p>AF –</p> <p>CF –</p> <p>DF –</p> <p>IF ✓</p> <p>OF –</p> <p>PF –</p> <p>SF –</p> <p>TF ✓</p> <p>ZF –</p>

NOTE: The three symbols used in the Flags Affected column are defined as follows:
 – the contents of the flag remain unchanged after the instruction is executed
 ? the contents of the flag is undefined after the instruction is executed
 ✓ the flag is updated after the instruction is executed

Table C-4. Instruction Set (Continued)

Name	Description	Operation	Flags Affected
INTO	<p>Interrupt on Overflow:</p> <p>INTO</p> <p>Generates a software interrupt if the overflow flag (OF) is set; otherwise control proceeds to the following instruction without activating an interrupt procedure. INTO addresses the target interrupt procedure (its type is 4) through the interrupt pointer at location 10H; it clears the TF and IF flags and otherwise operates like INT. INTO may be written following an arithmetic or logical operation to activate an interrupt procedure if overflow occurs.</p> <p>Instruction Operands:</p> <p>none</p>	<p>if</p> <p>(OF) = 1</p> <p>then</p> <p>(SP) ← (SP) – 2</p> <p>((SP) + 1:(SP)) ← FLAGS</p> <p>(IF) ← 0</p> <p>(TF) ← 0</p> <p>(SP) ← (SP) – 2</p> <p>((SP) + 1:(SP)) ← (CS)</p> <p>(CS) ← (12H)</p> <p>(SP) ← (SP) – 2</p> <p>((SP) + 1:(SP)) ← (IP)</p> <p>(IP) ← (10H)</p>	<p>AF –</p> <p>CF –</p> <p>DF –</p> <p>IF –</p> <p>OF –</p> <p>PF –</p> <p>SF –</p> <p>TF –</p> <p>ZF –</p>
IRET	<p>Interrupt Return:</p> <p>IRET</p> <p>Transfers control back to the point of interruption by popping IP, CS, and the flags from the stack. IRET thus affects all flags by restoring them to previously saved values. IRET is used to exit any interrupt procedure, whether activated by hardware or software.</p> <p>Instruction Operands:</p> <p>none</p>	<p>(IP) ← ((SP) + 1:(SP))</p> <p>(SP) ← (SP) + 2</p> <p>(CS) ← ((SP) + 1:(SP))</p> <p>(SP) ← (SP) + 2</p> <p>FLAGS ← ((SP) + 1:(SP))</p> <p>(SP) ← (SP) + 2</p>	<p>AF ✓</p> <p>CF ✓</p> <p>DF ✓</p> <p>IF ✓</p> <p>OF ✓</p> <p>PF ✓</p> <p>SF ✓</p> <p>TF ✓</p> <p>ZF ✓</p>
JA JNBE	<p>Jump on Above:</p> <p>Jump on Not Below or Equal:</p> <p>JA <i>disp8</i></p> <p>JNBE <i>disp8</i></p> <p>Transfers control to the target location if the tested condition ((CF=0) or (ZF=0)) is true.</p> <p>Instruction Operands:</p> <p>JA short-label</p> <p>JNBE short-label</p>	<p>if</p> <p>((CF) = 0) or ((ZF) = 0)</p> <p>then</p> <p>(IP) ← (IP) + <i>disp8</i> (sign-ext to 16 bits)</p>	<p>AF –</p> <p>CF –</p> <p>DF –</p> <p>IF –</p> <p>OF –</p> <p>PF –</p> <p>SF –</p> <p>TF –</p> <p>ZF –</p>

NOTE: The three symbols used in the Flags Affected column are defined as follows:

- the contents of the flag remain unchanged after the instruction is executed
- ? the contents of the flag is undefined after the instruction is executed
- ✓ the flag is updated after the instruction is executed

Table C-4. Instruction Set (Continued)

Name	Description	Operation	Flags Affected
JAE JNB	Jump on Above or Equal: Jump on Not Below: <i>JAE disp8</i> <i>JNB disp8</i> Transfers control to the target location if the tested condition (CF = 0) is true. Instruction Operands: JAE short-label JNB short-label	if (CF) = 0 then (IP) ← (IP) + disp8 (sign-ext to 16 bits)	AF – CF – DF – IF – OF – PF – SF – TF – ZF –
JB JNAE	Jump on Below: Jump on Not Above or Equal: <i>JB disp8</i> <i>JNAE disp8</i> Transfers control to the target location if the tested condition (CF = 1) is true. Instruction Operands: JB short-label JNAE short-label	if (CF) = 1 then (IP) ← (IP) + disp8 (sign-ext to 16 bits)	AF – CF – DF – IF – OF – PF – SF – TF – ZF –
JBE JNA	Jump on Below or Equal: Jump on Not Above: <i>JBE disp8</i> <i>JNA disp8</i> Transfers control to the target location if the tested condition ((C = 1) or (ZF=1)) is true. Instruction Operands: JBE short-label JNA short-label	if ((CF) = 1) or ((ZF) = 1) then (IP) ← (IP) + disp8 (sign-ext to 16 bits)	AF – CF – DF – IF – OF – PF – SF – TF – ZF –
JC	Jump on Carry: <i>JC disp8</i> Transfers control to the target location if the tested condition (CF=1) is true. Instruction Operands: JC short-label	if (CF) = 1 then (IP) ← (IP) + disp8 (sign-ext to 16 bits)	AF – CF – DF – IF – OF – PF – SF – TF – ZF –

NOTE: The three symbols used in the Flags Affected column are defined as follows:
 – the contents of the flag remain unchanged after the instruction is executed
 ? the contents of the flag is undefined after the instruction is executed
 ✓ the flag is updated after the instruction is executed

Table C-4. Instruction Set (Continued)

Name	Description	Operation	Flags Affected
JCXZ	<p>Jump if CX Zero:</p> <p><i>JCXZ disp8</i></p> <p>Transfers control to the target location if CX is 0. Useful at the beginning of a loop to bypass the loop if CX has a zero value, i.e., to execute the loop zero times.</p> <p>Instruction Operands:</p> <p>JCXZ short-label</p>	<p>if (CX) = 0 then (IP) ← (IP) + disp8 (sign-ext to 16 bits)</p>	<p>AF – CF – DF – IF – OF – PF – SF – TF – ZF –</p>
JE JZ	<p>Jump on Equal:</p> <p>Jump on Zero:</p> <p><i>JE disp8</i> <i>JZ disp8</i></p> <p>Transfers control to the target location if the condition tested (ZF = 1) is true.</p> <p>Instruction Operands:</p> <p>JE short-label JZ short-label</p>	<p>if (ZF) = 1 then (IP) ← (IP) + disp8 (sign-ext to 16 bits)</p>	<p>AF – CF – DF – IF – OF – PF – SF – TF – ZF –</p>
JG JNLE	<p>Jump on Greater Than:</p> <p>Jump on Not Less Than or Equal:</p> <p><i>JG disp8</i> <i>JNLE disp8</i></p> <p>Transfers control to the target location if the condition tested (SF = OF) and (ZF=0) is true.</p> <p>Instruction Operands:</p> <p>JG short-label JNLE short-label</p>	<p>if ((SF) = (OF)) and ((ZF) = 0) then (IP) ← (IP) + disp8 (sign-ext to 16 bits)</p>	<p>AF – CF – DF – IF – OF – PF – SF – TF – ZF –</p>
JGE JNL	<p>Jump on Greater Than or Equal:</p> <p>Jump on Not Less Than:</p> <p><i>JGE disp8</i> <i>JNL disp8</i></p> <p>Transfers control to the target location if the condition tested (SF=OF) is true.</p> <p>Instruction Operands:</p> <p>JGE short-label JNL short-label</p>	<p>if (SF) = (OF) then (IP) ← (IP) + disp8 (sign-ext to 16 bits)</p>	<p>AF – CF – DF – IF – OF – PF – SF – TF – ZF –</p>

NOTE: The three symbols used in the Flags Affected column are defined as follows:

- the contents of the flag remain unchanged after the instruction is executed
- ? the contents of the flag is undefined after the instruction is executed
- ✓ the flag is updated after the instruction is executed

Table C-4. Instruction Set (Continued)

Name	Description	Operation	Flags Affected
JL JNGE	Jump on Less Than: Jump on Not Greater Than or Equal: <i>JL disp8</i> <i>JNGE disp8</i> Transfers control to the target location if the condition tested (SF≠OF) is true. Instruction Operands: JL short-label JNGE short-label	if (SF) ≠ (OF) then (IP) ← (IP) + disp8 (sign-ext to 16 bits)	AF – CF – DF – IF – OF – PF – SF – TF – ZF –
JLE JNG	Jump on Less Than or Equal: Jump on Not Greater Than: <i>JGE disp8</i> <i>JNL disp8</i> Transfers control to the target location if the condition tested ((SF≠OF) or (ZF=0)) is true. Instruction Operands: JGE short-label JNL short-label	if ((SF) ≠ (OF)) or ((ZF) = 1) then (IP) ← (IP) + disp8 (sign-ext to 16 bits)	AF – CF – DF – IF – OF – PF – SF – TF – ZF –
JMP	Jump Unconditionally: <i>JMP target</i> Transfers control to the target location. Instruction Operands: JMP short-label JMP near-label JMP far-label JMP memptr JMP regptr	if Inter-segment then (CS) ← SEG (IP) ← dest	AF – CF – DF – IF – OF – PF – SF – TF – ZF –
JNC	Jump on Not Carry: <i>JNC disp8</i> Transfers control to the target location if the tested condition (CF=0) is true. Instruction Operands: JNC short-label	if (CF) = 0 then (IP) ← (IP) + disp8 (sign-ext to 16 bits)	AF – CF – DF – IF – OF – PF – SF – TF – ZF –

NOTE: The three symbols used in the Flags Affected column are defined as follows:
 – the contents of the flag remain unchanged after the instruction is executed
 ? the contents of the flag is undefined after the instruction is executed
 ✓ the flag is updated after the instruction is executed

Table C-4. Instruction Set (Continued)

Name	Description	Operation	Flags Affected
JNE JNZ	<p>Jump on Not Equal: Jump on Not Zero:</p> <p><i>JNE disp8</i> <i>JNZ disp8</i></p> <p>Transfers control to the target location if the tested condition (ZF = 0) is true.</p> <p>Instruction Operands:</p> <p>JNE short-label JNZ short-label</p>	<p>if (ZF) = 0 then (IP) ← (IP) + disp8 (sign-ext to 16 bits)</p>	<p>AF – CF – DF – IF – OF – PF – SF – TF – ZF –</p>
JNO	<p>Jump on Not Overflow:</p> <p><i>JNO disp8</i></p> <p>Transfers control to the target location if the tested condition (OF = 0) is true.</p> <p>Instruction Operands:</p> <p>JNO short-label</p>	<p>if (OF) = 0 then (IP) ← (IP) + disp8 (sign-ext to 16 bits)</p>	<p>AF – CF – DF – IF – OF – PF – SF – TF – ZF –</p>
JNS	<p>Jump on Not Sign:</p> <p><i>JNS disp8</i></p> <p>Transfers control to the target location if the tested condition (SF = 0) is true.</p> <p>Instruction Operands:</p> <p>JNS short-label</p>	<p>if (SF) = 0 then (IP) ← (IP) + disp8 (sign-ext to 16 bits)</p>	<p>AF – CF – DF – IF – OF – PF – SF – TF – ZF –</p>
JNP JPO	<p>Jump on Not Parity: Jump on Parity Odd:</p> <p><i>JNO disp8</i> <i>JPO disp8</i></p> <p>Transfers control to the target location if the tested condition (PF=0) is true.</p> <p>Instruction Operands:</p> <p>JNO short-label JPO short-label</p>	<p>if (PF) = 0 then (IP) ← (IP) + disp8 (sign-ext to 16 bits)</p>	<p>AF – CF – DF – IF – OF – PF – SF – TF – ZF –</p>

NOTE: The three symbols used in the Flags Affected column are defined as follows:
 – the contents of the flag remain unchanged after the instruction is executed
 ? the contents of the flag is undefined after the instruction is executed
 ✓ the flag is updated after the instruction is executed

Table C-4. Instruction Set (Continued)

Name	Description	Operation	Flags Affected
JO	Jump on Overflow: <i>JO disp8</i> Transfers control to the target location if the tested condition (OF = 1) is true. Instruction Operands: JO short-label	if (OF) = 1 then (IP) ← (IP) + disp8 (sign-ext to 16 bits)	AF – CF – DF – IF – OF – PF – SF – TF – ZF –
JP JPE	Jump on Parity: Jump on Parity Equal: <i>JP disp8</i> <i>JPE disp8</i> Transfers control to the target location if the tested condition (PF = 1) is true. Instruction Format: JP short-label JPE short-label	if (PF) = 1 then (IP) ← (IP) + disp8 (sign-ext to 16 bits)	AF – CF – DF – IF – OF – PF – SF – TF – ZF –
JS	Jump on Sign: <i>JS disp8</i> Transfers control to the target location if the tested condition (SF = 1) is true. Instruction Format: JS short-label	if (SF) = 1 then (IP) ← (IP) + disp8 (sign-ext to 16 bits)	AF – CF – DF – IF – OF – PF – SF – TF – ZF –
LAHF	Load Register AH From Flags: LAHF Copies SF, ZF, AF, PF and CF (the 8080/8085 flags) into bits 7, 6, 4, 2 and 0, respectively, of register AH. The content of bits 5, 3, and 1 are undefined. LAHF is provided primarily for converting 8080/8085 assembly language programs to run on an 8086 or 8088. Instruction Operands: none	(AH) ← (SF):(ZF):X:(AF):X:(PF):X:(CF)	AF – CF – DF – IF – OF – PF – SF – TF – ZF –

NOTE: The three symbols used in the Flags Affected column are defined as follows:

- the contents of the flag remain unchanged after the instruction is executed
- ? the contents of the flag is undefined after the instruction is executed
- ✓ the flag is updated after the instruction is executed

Table C-4. Instruction Set (Continued)

Name	Description	Operation	Flags Affected
LDS	<p>Load Pointer Using DS:</p> <p>LDS <i>dest, src</i></p> <p>Transfers a 32-bit pointer variable from the source operand, which must be a memory operand, to the destination operand and register DS. The offset word of the pointer is transferred to the destination operand, which may be any 16-bit general register. The segment word of the pointer is transferred to register DS.</p> <p>Instruction Operands:</p> <p>LDS reg16, mem32</p>	$(dest) \leftarrow (EA)$ $(DS) \leftarrow (EA + 2)$	AF – CF – DF – IF – OF – PF – SF – TF – ZF –
LEA	<p>Load Effective Address:</p> <p>LEA <i>dest, src</i></p> <p>Transfers the offset of the source operand (rather than its value) to the destination operand.</p> <p>Instruction Operands:</p> <p>LEA reg16, mem16</p>	$(dest) \leftarrow EA$	AF – CF – DF – IF – OF – PF – SF – TF – ZF –
LEAVE	<p>Leave:</p> <p>LEAVE</p> <p>Reverses the action of the most recent ENTER instruction. Collapses the last stack frame created. First, LEAVE copies the current BP to the stack pointer releasing the stack space allocated to the current procedure. Second, LEAVE pops the old value of BP from the stack, to return to the calling procedure's stack frame. A return (RET) instruction will remove arguments stacked by the calling procedure for use by the called procedure.</p> <p>Instruction Operands:</p> <p>none</p>	$(SP) \leftarrow (BP)$ $(BP) \leftarrow ((SP) + 1):(SP)$ $(SP) \leftarrow (SP) + 2$	AF – CF – DF – IF – OF – PF – SF – TF – ZF –

NOTE: The three symbols used in the Flags Affected column are defined as follows:

- the contents of the flag remain unchanged after the instruction is executed
- ? the contents of the flag is undefined after the instruction is executed
- ✓ the flag is updated after the instruction is executed

Table C-4. Instruction Set (Continued)

Name	Description	Operation	Flags Affected
LES	<p>Load Pointer Using ES: LES <i>dest, src</i></p> <p>Transfers a 32-bit pointer variable from the source operand to the destination operand and register ES. The offset word of the pointer is transferred to the destination operand. The segment word of the pointer is transferred to register ES.</p> <p>Instruction Operands: LES reg16, mem32</p>	<p>(dest) ← (EA) (ES) ← (EA + 2)</p>	<p>AF – CF – DF – IF – OF – PF – SF – TF – ZF –</p>
LOCK	<p>Lock the Bus: LOCK</p> <p>Causes the 8088 (configured in maximum mode) to assert its bus LOCK signal while the following instruction executes. The instruction most useful in this context is an exchange register with memory.</p> <p>The LOCK prefix may be combined with the segment override and/or REP prefixes.</p> <p>Instruction Operands: none</p>	<p>none</p>	<p>AF – CF – DF – IF – OF – PF – SF – TF – ZF –</p>

NOTE: The three symbols used in the Flags Affected column are defined as follows:
 – the contents of the flag remain unchanged after the instruction is executed
 ? the contents of the flag is undefined after the instruction is executed
 ✓ the flag is updated after the instruction is executed

Table C-4. Instruction Set (Continued)

Name	Description	Operation	Flags Affected
LODS	<p>Load String (Byte or Word):</p> <p>LODS <i>src-string</i></p> <p>Transfers the byte or word string element addressed by SI to register AL or AX and updates SI to point to the next element in the string. This instruction is not ordinarily repeated since the accumulator would be overwritten by each repetition, and only the last element would be retained.</p> <p>Instruction Operands:</p> <p>LODS <i>src-string</i> LODS (repeat) <i>src-string</i></p>	<p>When Source Operand is a Byte:</p> <p>(AL) ← (src-string) if (DF) = 0 then (SI) ← (SI) + DELTA else (SI) ← (SI) – DELTA</p> <p>When Source Operand is a Word:</p> <p>(AX) ← (src-string) if (DF) = 0 then (SI) ← (SI) + DELTA else (SI) ← (SI) – DELTA</p>	<p>AF – CF – DF – IF – OF – PF – SF – TF – ZF –</p>
LOOP	<p>Loop:</p> <p>LOOP <i>disp8</i></p> <p>Decrements CX by 1 and transfers control to the target location if CX is not 0; otherwise the instruction following LOOP is executed.</p> <p>Instruction Operands:</p> <p>LOOP short-label</p>	<p>(CX) ← (CX) – 1 if (CX) ≠ 0 then (IP) ← (IP) + <i>disp8</i> (sign-ext to 16 bits)</p>	<p>AF – CF – DF – IF – OF – PF – SF – TF – ZF –</p>
LOOPE LOOPZ	<p>Loop While Equal: Loop While Zero:</p> <p>LOOPE <i>disp8</i> LOOPZ <i>disp8</i></p> <p>Decrements CX by 1 and transfers control to the target location if CX is not 0 and if ZF is set; otherwise the next sequential instruction is executed.</p> <p>Instruction Operands:</p> <p>LOOPE short-label LOOPZ short-label</p>	<p>(CX) ← (CX) – 1 if (ZF) = 1 and (CX) ≠ 0 then (IP) ← (IP) + <i>disp8</i> (sign-ext to 16 bits)</p>	<p>AF – CF – DF – IF – OF – PF – SF – TF – ZF –</p>

NOTE: The three symbols used in the Flags Affected column are defined as follows:
 – the contents of the flag remain unchanged after the instruction is executed
 ? the contents of the flag is undefined after the instruction is executed
 ✓ the flag is updated after the instruction is executed

Table C-4. Instruction Set (Continued)

Name	Description	Operation	Flags Affected
LOOPNE LOOPNZ	<p>Loop While Not Equal: Loop While Not Zero:</p> <p>LOOPNE <i>disp8</i> LOOPNZ <i>disp8</i></p> <p>Decrements CX by 1 and transfers control to the target location if CX is not 0 and if ZF is clear; otherwise the next sequential instruction is executed.</p> <p>Instruction Operands: LOOPNE short-label LOOPNZ short-label</p>	$(CX) \leftarrow (CX) - 1$ if $(ZF) = 0$ and $(CX) \neq 0$ then $(IP) \leftarrow (IP) + \text{disp8}$ (sign-ext to 16 bits)	AF – CF – DF – IF – OF – PF – SF – TF – ZF –
MOV	<p>Move (Byte or Word):</p> <p>MOV <i>dest, src</i></p> <p>Transfers a byte or a word from the source operand to the destination operand.</p> <p>Instruction Operands:</p> <p>MOV mem, accum MOV accum, mem MOV reg, reg MOV reg, mem MOV mem, reg MOV reg, immed MOV mem, immed MOV seg-reg, reg16 MOV seg-reg, mem16 MOV reg16, seg-reg MOV mem16, seg-reg</p>	$(\text{dest}) \leftarrow (\text{src})$	AF – CF – DF – IF – OF – PF – SF – TF – ZF –

NOTE: The three symbols used in the Flags Affected column are defined as follows:
 – the contents of the flag remain unchanged after the instruction is executed
 ? the contents of the flag is undefined after the instruction is executed
 ✓ the flag is updated after the instruction is executed

Table C-4. Instruction Set (Continued)

Name	Description	Operation	Flags Affected
MOVS	<p>Move String: MOVS <i>dest-string, src-string</i></p> <p>Transfers a byte or a word from the source string (addressed by SI) to the destination string (addressed by DI) and updates SI and DI to point to the next string element. When used in conjunction with REP, MOVS performs a memory-to-memory block transfer.</p> <p>Instruction Operands: MOVS <i>dest-string, src-string</i> MOVS (repeat) <i>dest-string, src-string</i></p>	$(\text{dest-string}) \leftarrow (\text{src-string})$	AF – CF – DF – IF – OF – PF – SF – TF – ZF –
MUL	<p>Multiply: MUL <i>src</i></p> <p>Performs an unsigned multiplication of the source operand and the accumulator. If the source is a byte, then it is multiplied by register AL, and the double-length result is returned in AH and AL. If the source operand is a word, then it is multiplied by register AX, and the double-length result is returned in registers DX and AX. The operands are treated as unsigned binary numbers (see AAM). If the upper half of the result (AH for byte source, DX for word source) is non-zero, CF and OF are set; otherwise they are cleared.</p> <p>Instruction Operands: MUL <i>reg</i> MUL <i>mem</i></p>	<p>When Source Operand is a Byte: $(AX) \leftarrow (AL) \times (\text{src})$ if (AH) = 0 then (CF) \leftarrow 0 else (CF) \leftarrow 1 (OF) \leftarrow (CF)</p> <p>When Source Operand is a Word: $(DX:AX) \leftarrow (AX) \times (\text{src})$ if (DX) = 0 then (CF) \leftarrow 0 else (CF) \leftarrow 1 (OF) \leftarrow (CF)</p>	AF ? CF ✓ DF – IF – OF ✓ PF ? SF ? TF – ZF ?

NOTE: The three symbols used in the Flags Affected column are defined as follows:
– the contents of the flag remain unchanged after the instruction is executed
? the contents of the flag is undefined after the instruction is executed
✓ the flag is updated after the instruction is executed

Table C-4. Instruction Set (Continued)

Name	Description	Operation	Flags Affected
NEG	<p>Negate: NEG <i>dest</i></p> <p>Subtracts the destination operand, which may be a byte or a word, from 0 and returns the result to the destination. This forms the two's complement of the number, effectively reversing the sign of an integer. If the operand is zero, its sign is not changed. Attempting to negate a byte containing -128 or a word containing -32,768 causes no change to the operand and sets OF.</p> <p>Instruction Operands: NEG reg NEG mem</p>	<p>When Source Operand is a Byte: $(dest) \leftarrow FFH - (dest)$ $(dest) \leftarrow (dest) + 1$ (affecting flags)</p> <p>When Source Operand is a Word: $(dest) \leftarrow FFFFH - (dest)$ $(dest) \leftarrow (dest) + 1$ (affecting flags)</p>	AF ✓ CF ✓ DF - IF - OF ✓ PF ✓ SF ✓ TF - ZF ✓
NOP	<p>No Operation: NOP</p> <p>Causes the CPU to do nothing.</p> <p>Instruction Operands: none</p>	None	AF - CF - DF - IF - OF - PF - SF - TF - ZF -
NOT	<p>Logical Not: NOT <i>dest</i></p> <p>Inverts the bits (forms the one's complement) of the byte or word operand.</p> <p>Instruction Operands: NOT reg NOT mem</p>	<p>When Source Operand is a Byte: $(dest) \leftarrow FFH - (dest)$</p> <p>When Source Operand is a Word: $(dest) \leftarrow FFFFH - (dest)$</p>	AF - CF - DF - IF - OF - PF - SF - TF - ZF -

NOTE: The three symbols used in the Flags Affected column are defined as follows:
 - the contents of the flag remain unchanged after the instruction is executed
 ? the contents of the flag is undefined after the instruction is executed
 ✓ the flag is updated after the instruction is executed

Table C-4. Instruction Set (Continued)

Name	Description	Operation	Flags Affected
OR	<p>Logical OR: OR <i>dest,src</i></p> <p>Performs the logical "inclusive or" of the two operands (bytes or words) and returns the result to the destination operand. A bit in the result is set if either or both corresponding bits in the original operands are set; otherwise the result bit is cleared.</p> <p>Instruction Operands:</p> <p>OR reg, reg OR reg, mem OR mem, reg OR accum, immed OR reg, immed OR mem, immed</p>	<p>(dest) ← (dest) or (src) (CF) ← 0 (OF) ← 0</p>	<p>AF ? CF ✓ DF – IF – OF ✓ PF ✓ SF ✓ TF – ZF ✓</p>
OUT	<p>Output: OUT <i>port, accumulator</i></p> <p>Transfers a byte or a word from the AL register or the AX register, respectively, to an output port. The port number may be specified either with an immediate byte constant, allowing access to ports numbered 0 through 255, or with a number previously placed in register DX, allowing variable access (by changing the value in DX) to ports numbered from 0 through 65,535.</p> <p>Instruction Operands:</p> <p>OUT immed8, AL OUT DX, AX</p>	<p>(dest) ← (src)</p>	<p>AF – CF – DF – IF – OF – PF – SF – TF – ZF –</p>

NOTE: The three symbols used in the Flags Affected column are defined as follows:
 – the contents of the flag remain unchanged after the instruction is executed
 ? the contents of the flag is undefined after the instruction is executed
 ✓ the flag is updated after the instruction is executed

Table C-4. Instruction Set (Continued)

Name	Description	Operation	Flags Affected
OUTS	<p>Out String: OUTS <i>port, src_string</i></p> <p>Performs block output from memory to an I/O port. The port address is placed in the DX register. The memory address is placed in the SI register. This instruction uses the DS segment register, but this may be changed with a segment override instruction. After the data transfer takes place, the pointer register (SI) increments or decrements, depending on the value of the direction flag (DF). The pointer register changes by 1 for byte transfers or 2 for word transfers.</p> <p>Instruction Operands: OUTS <i>port, src_string</i> OUTS (repeat) <i>port, src_string</i></p>	$(dst) \leftarrow (src)$	AF – CF – DF – IF – OF – PF – SF – TF – ZF –
POP	<p>Pop: POP <i>dest</i></p> <p>Transfers the word at the current top of stack (pointed to by SP) to the destination operand and then increments SP by two to point to the new top of stack.</p> <p>Instruction Operands: POP <i>reg</i> POP <i>seg-reg</i> (CS illegal) POP <i>mem</i></p>	$(dest) \leftarrow ((SP) + 1:(SP))$ $(SP) \leftarrow (SP) + 2$	AF – CF – DF – IF – OF – PF – SF – TF – ZF –

NOTE: The three symbols used in the Flags Affected column are defined as follows:
 – the contents of the flag remain unchanged after the instruction is executed
 ? the contents of the flag is undefined after the instruction is executed
 ✓ the flag is updated after the instruction is executed

Table C-4. Instruction Set (Continued)

Name	Description	Operation	Flags Affected
POPA	<p>Pop All: POPA</p> <p>Pops all data, pointer, and index registers off of the stack. The SP value popped is discarded.</p> <p>Instruction Operands: none</p>	$(DI) \leftarrow ((SP) + 1:(SP))$ $(SP) \leftarrow (SP) + 2$ $(SI) \leftarrow ((SP) + 1:(SP))$ $(SP) \leftarrow (SP) + 2$ $(BP) \leftarrow ((SP) + 1:(SP))$ $(SP) \leftarrow (SP) + 2$ $(BX) \leftarrow ((SP) + 1:(SP))$ $(SP) \leftarrow (SP) + 2$ $(DX) \leftarrow ((SP) + 1:(SP))$ $(SP) \leftarrow (SP) + 2$ $(CX) \leftarrow ((SP) + 1:(SP))$ $(SP) \leftarrow (SP) + 2$ $(AX) \leftarrow ((SP) + 1:(SP))$ $(SP) \leftarrow (SP) + 2$	AF – CF – DF – IF – OF – PF – SF – TF – ZF –
POPF	<p>Pop Flags: POPF</p> <p>Transfers specific bits from the word at the current top of stack (pointed to by register SP) into the 8086/8088 flags, replacing whatever values the flags previously contained. SP is then incremented by two to point to the new top of stack.</p> <p>Instruction Operands: none</p>	$Flags \leftarrow ((SP) + 1:(SP))$ $(SP) \leftarrow (SP) + 2$	AF ✓ CF ✓ DF ✓ IF ✓ OF ✓ PF ✓ SF ✓ TF ✓ ZF ✓
PUSH	<p>Push: PUSH <i>src</i></p> <p>Decrements SP by two and then transfers a word from the source operand to the top of stack now pointed to by SP.</p> <p>Instruction Operands: PUSH reg PUSH seg-reg (CS legal) PUSH mem</p>	$(SP) \leftarrow (SP) - 2$ $((SP) + 1:(SP)) \leftarrow (src)$	AF – CF – DF – IF – OF – PF – SF – TF – ZF –

NOTE: The three symbols used in the Flags Affected column are defined as follows:
 – the contents of the flag remain unchanged after the instruction is executed
 ? the contents of the flag is undefined after the instruction is executed
 ✓ the flag is updated after the instruction is executed

Table C-4. Instruction Set (Continued)

Name	Description	Operation	Flags Affected
PUSHA	<p>Push All: PUSHA</p> <p>Pushes all data, pointer, and index registers onto the stack. The order in which the registers are saved is: AX, CX, DX, BX, SP, BP, SI, and DI. The SP value pushed is the SP value before the first register (AX) is pushed.</p> <p>Instruction Operands: none</p>	<p>temp ← (SP) (SP) ← (SP) – 2 ((SP) + 1:(SP)) ← (AX) (SP) ← (SP) – 2 ((SP) + 1:(SP)) ← (CX) (SP) ← (SP) – 2 ((SP) + 1:(SP)) ← (DX) (SP) ← (SP) – 2 ((SP) + 1:(SP)) ← (BX) (SP) ← (SP) – 2 ((SP) + 1:(SP)) ← (temp) (SP) ← (SP) – 2 ((SP) + 1:(SP)) ← (BP) (SP) ← (SP) – 2 ((SP) + 1:(SP)) ← (SI) (SP) ← (SP) – 2 ((SP) + 1:(SP)) ← (DI)</p>	<p>AF – CF – DF – IF – OF – PF – SF – TF – ZF –</p>
PUSHF	<p>Push Flags: PUSHF</p> <p>Decrements SP by two and then transfers all flags to the word at the top of stack pointed to by SP.</p> <p>Instruction Operands: none</p>	<p>(SP) ← (SP) – 2 ((SP) + 1:(SP)) ← Flags</p>	<p>AF – CF – DF – IF – OF – PF – SF – TF – ZF –</p>

NOTE: The three symbols used in the Flags Affected column are defined as follows:
 – the contents of the flag remain unchanged after the instruction is executed
 ? the contents of the flag is undefined after the instruction is executed
 ✓ the flag is updated after the instruction is executed

Table C-4. Instruction Set (Continued)

Name	Description	Operation	Flags Affected
RCL	<p>Rotate Through Carry Left:</p> <p>RCL <i>dest, count</i></p> <p>Rotates the bits in the byte or word destination operand to the left by the number of bits specified in the count operand. The carry flag (CF) is treated as "part of" the destination operand; that is, its value is rotated into the low-order bit of the destination, and itself is replaced by the high-order bit of the destination.</p> <p>Instruction Operands:</p> <p>RCL reg, n RCL mem, n RCL reg, CL RCL mem, CL</p>	<pre>(temp) ← count do while (temp) ≠ 0 (tmpcf) ← (CF) (CF) ← high-order bit of (dest) (dest) ← (dest) × 2 + (tmpcf) (temp) ← (temp) - 1 if count = 1 then if high-order bit of (dest) ≠ (CF) then (OF) ← 1 else (OF) ← 0 else (OF) undefined</pre>	<p>AF –</p> <p>CF ✓</p> <p>DF –</p> <p>IF –</p> <p>OF ✓</p> <p>PF –</p> <p>SF –</p> <p>TF –</p> <p>ZF –</p>
RCR	<p>Rotate Through Carry Right:</p> <p>RCR <i>dest, count</i></p> <p>Operates exactly like RCL except that the bits are rotated right instead of left.</p> <p>Instruction Operands:</p> <p>RCR reg, n RCR mem, n RCR reg, CL RCR mem, CL</p>	<pre>(temp) ← count do while (temp) ≠ 0 (tmpcf) ← (CF) (CF) ← low-order bit of (dest) (dest) ← (dest) / 2 high-order bit of (dest) ← (tmpcf) (temp) ← (temp) - 1 if count = 1 then if high-order bit of (dest) ≠ next-to-high-order bit of (dest) then (OF) ← 1 else (OF) ← 0 else (OF) undefined</pre>	<p>AF –</p> <p>CF ✓</p> <p>DF –</p> <p>IF –</p> <p>OF ✓</p> <p>PF –</p> <p>SF –</p> <p>TF –</p> <p>ZF –</p>

NOTE: The three symbols used in the Flags Affected column are defined as follows:

- the contents of the flag remain unchanged after the instruction is executed
- ? the contents of the flag is undefined after the instruction is executed
- ✓ the flag is updated after the instruction is executed

Table C-4. Instruction Set (Continued)

Name	Description	Operation	Flags Affected
REP REPE REPZ REPNE REPNZ	<p>Repeat:</p> <p>Repeat While Equal:</p> <p>Repeat While Zero:</p> <p>Repeat While Not Equal:</p> <p>Repeat While Not Zero:</p> <p>Controls subsequent string instruction repetition. The different mnemonics are provided to improve program clarity.</p> <p>REP is used in conjunction with the MOVS (Move String) and STOS (Store String) instructions and is interpreted as "repeat while not end-of-string" (CX not 0).</p> <p>REPE and REPZ operate identically and are physically the same prefix byte as REP. These instructions are used with the CMPS (Compare String) and SCAS (Scan String) instructions and require ZF (posted by these instructions) to be set before initiating the next repetition.</p> <p>REPNE and REPNZ are mnemonics for the same prefix byte. These instructions function the same as REPE and REPZ except that the zero flag must be cleared or the repetition is terminated. ZF does not need to be initialized before executing the repeated string instruction.</p> <p>Instruction Operands:</p> <p>none</p>	<p>do while (CX) ≠ 0</p> <p>service pending interrupts (if any)</p> <p>execute primitive string</p> <p>Operation in succeeding byte</p> <p>(CX) ← (CX) – 1</p> <p>if</p> <p>primitive operation is CMPB, CMPW, SCAB, or SCAW and (ZF) ≠ 0</p> <p>then</p> <p>exit from while loop</p>	<p>AF –</p> <p>CF –</p> <p>DF –</p> <p>IF –</p> <p>OF –</p> <p>PF –</p> <p>SF –</p> <p>TF –</p> <p>ZF –</p>

NOTE: The three symbols used in the Flags Affected column are defined as follows:

- the contents of the flag remain unchanged after the instruction is executed
- ? the contents of the flag is undefined after the instruction is executed
- ✓ the flag is updated after the instruction is executed

Table C-4. Instruction Set (Continued)

Name	Description	Operation	Flags Affected
RET	<p>Return:</p> <p>RET <i>optional-pop-value</i></p> <p>Transfers control from a procedure back to the instruction following the CALL that activated the procedure. The assembler generates an intrasegment RET if the programmer has defined the procedure near, or an intersegment RET if the procedure has been defined as far. RET pops the word at the top of the stack (pointed to by register SP) into the instruction pointer and increments SP by two. If RET is intersegment, the word at the new top of stack is popped into the CS register, and SP is again incremented by two. If an optional pop value has been specified, RET adds that value to SP.</p> <p>Instruction Operands:</p> <p>RET immed8</p>	$(IP) \leftarrow ((SP) = 1:(SP))$ $(SP) \leftarrow (SP) + 2$ if inter-segment then $(CS) \leftarrow ((SP) + 1:(SP))$ $(SP) \leftarrow (SP) + 2$ if add immed8 to SP then $(SP) \leftarrow (SP) + \text{data}$	AF – CF – DF – IF – OF – PF – SF – TF – ZF –
ROL	<p>Rotate Left:</p> <p>ROL <i>dest, count</i></p> <p>Rotates the destination byte or word left by the number of bits specified in the count operand.</p> <p>Instruction Operands:</p> <p>ROL reg, n ROL mem, n ROL reg, CL ROL mem CL</p>	$(\text{temp}) \leftarrow \text{count}$ do while $(\text{temp}) \neq 0$ $(CF) \leftarrow \text{high-order bit of } (\text{dest})$ $(\text{dest}) \leftarrow (\text{dest}) \times 2 + (CF)$ $(\text{temp}) \leftarrow (\text{temp}) - 1$ if count = 1 then if high-order bit of $(\text{dest}) \neq (CF)$ then $(OF) \leftarrow 1$ else $(OF) \leftarrow 0$ else (OF) undefined	AF – CF ✓ DF – IF – OF ✓ PF – SF – TF – ZF –

NOTE: The three symbols used in the Flags Affected column are defined as follows:
– the contents of the flag remain unchanged after the instruction is executed
? the contents of the flag is undefined after the instruction is executed
✓ the flag is updated after the instruction is executed

Table C-4. Instruction Set (Continued)

Name	Description	Operation	Flags Affected
ROR	<p>Rotate Right: ROR <i>dest, count</i></p> <p>Operates similar to ROL except that the bits in the destination byte or word are rotated right instead of left.</p> <p>Instruction Operands: ROR reg, n ROR mem, n ROR reg, CL ROR mem, CL</p>	<pre>(temp) ← count do while (temp) ≠ 0 (CF) ← low-order bit of (dest) (dest) ← (dest) / 2 high-order bit of (dest) ← (CF) (temp) ← (temp) - 1 if count = 1 then if high-order bit of (dest) ≠ next-to-high-order bit of (dest) then (OF) ← 1 else (OF) ← 0 else (OF) undefined</pre>	<p>AF – CF ✓ DF – IF – OF ✓ PF – SF – TF – ZF –</p>
SAHF	<p>Store Register AH Into Flags: SAHF</p> <p>Transfers bits 7, 6, 4, 2, and 0 from register AH into SF, ZF, AF, PF, and CF, respectively, replacing whatever values these flags previously had.</p> <p>Instruction Operands: none</p>	<pre>(SF):(ZF):X:(AF):X:(PF):X:(CF) ← (AH)</pre>	<p>AF ✓ CF ✓ DF – IF – OF – PF ✓ SF ✓ TF – ZF ✓</p>

NOTE: The three symbols used in the Flags Affected column are defined as follows:
– the contents of the flag remain unchanged after the instruction is executed
? the contents of the flag is undefined after the instruction is executed
✓the flag is updated after the instruction is executed

Table C-4. Instruction Set (Continued)

Name	Description	Operation	Flags Affected
SHL SAL	<p>Shift Logical Left:</p> <p>Shift Arithmetic Left:</p> <p><i>SHL dest, count</i> <i>SAL dest, count</i></p> <p>Shifts the destination byte or word left by the number of bits specified in the count operand. Zeros are shifted in on the right. If the sign bit retains its original value, then OF is cleared.</p> <p>Instruction Operands:</p> <p>SHL reg, n SAL reg, n SHL mem, n SAL mem, n SHL reg, CL SAL reg, CL SHL mem, CL SAL mem, CL</p>	<pre>(temp) ← count do while (temp) ≠ 0 (CF) ← high-order bit of (dest) (dest) ← (dest) × 2 (temp) ← (temp) - 1 if count = 1 then if high-order bit of (dest) ≠ (CE) then (OF) ← 1 else (OF) ← 0 else (OF) undefined</pre>	<p>AF ?</p> <p>CF ✓</p> <p>DF –</p> <p>IF –</p> <p>OF ✓</p> <p>PF ✓</p> <p>SF ✓</p> <p>TF –</p> <p>ZF ✓</p>
SAR	<p>Shift Arithmetic Right:</p> <p><i>SAR dest, count</i></p> <p>Shifts the bits in the destination operand (byte or word) to the right by the number of bits specified in the count operand. Bits equal to the original high-order (sign) bit are shifted in on the left, preserving the sign of the original value. Note that SAR does not produce the same result as the dividend of an "equivalent" IDIV instruction if the destination operand is negative and 1 bits are shifted out. For example, shifting –5 right by one bit yields –3, while integer division –5 by 2 yields –2. The difference in the instructions is that IDIV truncates all numbers toward zero, while SAR truncates positive numbers toward zero and negative numbers toward negative infinity.</p> <p>Instruction Operands:</p> <p>SAR reg, n SAR mem, n SAR reg, CL SAR mem, CL</p>	<pre>(temp) ← count do while (temp) ≠ 0 (CF) ← low-order bit of (dest) (dest) ← (dest) / 2 (temp) ← (temp) - 1 if count = 1 then if high-order bit of (dest) ≠ next-to-high-order bit of (dest) then (OF) ← 1 else (OF) ← 0 else (OF) ← 0</pre>	<p>AF ?</p> <p>CF ✓</p> <p>DF –</p> <p>IF –</p> <p>OF ✓</p> <p>PF ✓</p> <p>SF ✓</p> <p>TF –</p> <p>ZF ✓</p>

NOTE: The three symbols used in the Flags Affected column are defined as follows:

- the contents of the flag remain unchanged after the instruction is executed
- ? the contents of the flag is undefined after the instruction is executed
- ✓ the flag is updated after the instruction is executed

Table C-4. Instruction Set (Continued)

Name	Description	Operation	Flags Affected
SBB	<p>Subtract With Borrow:</p> <p>SBB <i>dest, src</i></p> <p>Subtracts the source from the destination, subtracts one if CF is set, and returns the result to the destination operand. Both operands may be bytes or words. Both operands may be signed or unsigned binary numbers (see AAS and DAS)</p> <p>Instruction Operands:</p> <p>SBB reg, reg SBB reg, mem SBB mem, reg SBB accum, immed SBB reg, immed SBB mem, immed</p>	<p>if (CF) = 1 then (dest) = (dest) – (src) – 1 else (dest) ← (dest) – (src)</p>	<p>AF ✓ CF ✓ DF – IF – OF ✓ PF ✓ SF ✓ TF – ZF ✓</p>

NOTE: The three symbols used in the Flags Affected column are defined as follows:
 – the contents of the flag remain unchanged after the instruction is executed
 ? the contents of the flag is undefined after the instruction is executed
 ✓ the flag is updated after the instruction is executed

Table C-4. Instruction Set (Continued)

Name	Description	Operation	Flags Affected
SCAS	<p>Scan String: SCAS <i>dest-string</i></p> <p>Subtracts the destination string element (byte or word) addressed by DI from the content of AL (byte string) or AX (word string) and updates the flags, but does not alter the destination string or the accumulator. SCAS also updates DI to point to the next string element and AF, CF, OF, PF, SF and ZF to reflect the relationship of the scan value in AL/AX to the string element. If SCAS is prefixed with REPE or REPZ, the operation is interpreted as "scan while not end-of-string (CX not 0) and string-element = scan-value (ZF = 1)." This form may be used to scan for departure from a given value. If SCAS is prefixed with REPNE or REPNZ, the operation is interpreted as "scan while not end-of-string (CX not 0) and string-element is not equal to scan-value (ZF = 0)."</p> <p>Instruction Operands: SCAS <i>dest-string</i> SCAS (repeat) <i>dest-string</i></p>	<p>When Source Operand is a Byte: (AL) – (byte-string) if (DF) = 0 then (DI) ← (DI) + DELTA else (DI) ← (DI) – DELTA</p> <p>When Source Operand is a Word: (AX) – (word-string) if (DF) = 0 then (DI) ← (DI) + DELTA else (DI) ← (DI) – DELTA</p>	AF ✓ CF ✓ DF – IF – OF ✓ PF ✓ SF ✓ TF – ZF ✓

NOTE: The three symbols used in the Flags Affected column are defined as follows:
 – the contents of the flag remain unchanged after the instruction is executed
 ? the contents of the flag is undefined after the instruction is executed
 ✓ the flag is updated after the instruction is executed

Table C-4. Instruction Set (Continued)

Name	Description	Operation	Flags Affected
SHR	<p>Shift Logical Right: SHR <i>dest, src</i></p> <p>Shifts the bits in the destination operand (byte or word) to the right by the number of bits specified in the count operand. Zeros are shifted in on the left. If the sign bit retains its original value, then OF is cleared.</p> <p>Instruction Operands: SHR reg, n SHR mem, n SHR reg, CL SHR mem, CL</p>	<pre>(temp) ← count do while (temp) ≠ 0 (CF) ← low-order bit of (dest) (dest) ← (dest) / 2 (temp) ← (temp) - 1 if count = 1 then if high-order bit of (dest) ≠ next-to-high-order bit of (dest) then (OF) ← 1 else (OF) ← 0 else (OF) undefined</pre>	<p>AF ? CF ✓ DF – IF – OF ✓ PF ✓ SF ✓ TF – ZF ✓</p>
STC	<p>Set Carry Flag: STC</p> <p>Sets CF to 1.</p> <p>Instruction Operands: none</p>	<pre>(CF) ← 1</pre>	<p>AF – CF ✓ DF – IF – OF – PF – SF – TF – ZF –</p>
STD	<p>Set Direction Flag: STD</p> <p>Sets DF to 1 causing the string instructions to auto-decrement the SI and/or DI index registers.</p> <p>Instruction Operands: none</p>	<pre>(DF) ← 1</pre>	<p>AF – CF – DF ✓ IF – OF – PF – SF – TF – ZF –</p>

NOTE: The three symbols used in the Flags Affected column are defined as follows:
 – the contents of the flag remain unchanged after the instruction is executed
 ? the contents of the flag is undefined after the instruction is executed
 ✓ the flag is updated after the instruction is executed

Table C-4. Instruction Set (Continued)

Name	Description	Operation	Flags Affected
STI	<p>Set Interrupt-enable Flag:</p> <p>STI</p> <p>Sets IF to 1, enabling processor recognition of maskable interrupt requests appearing on the INTR line. Note however, that a pending interrupt will not actually be recognized until the instruction following STI has executed.</p> <p>Instruction Operands:</p> <p>none</p>	$(IF) \leftarrow 1$	AF – CF – DF – IF ✓ OF – PF – SF – TF – ZF –
STOS	<p>Store (Byte or Word) String:</p> <p>STOS <i>dest-string</i></p> <p>Transfers a byte or word from register AL or AX to the string element addressed by DI and updates DI to point to the next location in the string. As a repeated operation.</p> <p>Instruction Operands:</p> <p>STOS <i>dest-string</i> STOS (repeat) <i>dest-string</i></p>	<p>When Source Operand is a Byte:</p> $(DEST) \leftarrow (AL)$ if $(DF) = 0$ then $(DI) \leftarrow (DI) + DELTA$ else $(DI) \leftarrow (DI) - DELTA$ <p>When Source Operand is a Word:</p> $(DEST) \leftarrow (AX)$ if $(DF) = 0$ then $(DI) \leftarrow (DI) + DELTA$ else $(DI) \leftarrow (DI) - DELTA$	AF – CF – DF – IF – OF – PF – SF – TF – ZF –

NOTE: The three symbols used in the Flags Affected column are defined as follows:
 – the contents of the flag remain unchanged after the instruction is executed
 ? the contents of the flag is undefined after the instruction is executed
 ✓ the flag is updated after the instruction is executed

Table C-4. Instruction Set (Continued)

Name	Description	Operation	Flags Affected
SUB	<p>Subtract: SUB <i>dest, src</i></p> <p>The source operand is subtracted from the destination operand, and the result replaces the destination operand. The operands may be bytes or words. Both operands may be signed or unsigned binary numbers (see AAS and DAS).</p> <p>Instruction Operands: SUB reg, reg SUB reg, mem SUB mem, reg SUB accum, immed SUB reg, immed SUB mem, immed</p>	$(dest) \leftarrow (dest) - (src)$	AF ✓ CF ✓ DF – IF – OF ✓ PF ✓ SF ✓ TF – ZF ✓
TEST	<p>Test: TEST <i>dest, src</i></p> <p>Performs the logical "and" of the two operands (bytes or words), updates the flags, but does not return the result, i.e., neither operand is changed. If a TEST instruction is followed by a JNZ (jump if not zero) instruction, the jump will be taken if there are any corresponding one bits in both operands.</p> <p>Instruction Operands: TEST reg, reg TEST reg, mem TEST accum, immed TEST reg, immed TEST mem, immed</p>	$(dest)$ and (src) $(CF) \leftarrow 0$ $(OF) \leftarrow 0$	AF ? CF ✓ DF – IF – OF ✓ PF ✓ SF ✓ TF – ZF ✓

NOTE: The three symbols used in the Flags Affected column are defined as follows:
 – the contents of the flag remain unchanged after the instruction is executed
 ? the contents of the flag is undefined after the instruction is executed
 ✓ the flag is updated after the instruction is executed

Table C-4. Instruction Set (Continued)

Name	Description	Operation	Flags Affected
WAIT	<p>Wait: WAIT</p> <p>Causes the CPU to enter the wait state while its test line is not active.</p> <p>Instruction Operands: none</p>	None	AF – CF – DF – IF – OF – PF – SF – TF – ZF –
XCHG	<p>Exchange: XCHG <i>dest, src</i></p> <p>Switches the contents of the source and destination operands (bytes or words). When used in conjunction with the LOCK prefix, XCHG can test and set a semaphore that controls access to a resource shared by multiple processors.</p> <p>Instruction Operands: XCHG accum, reg XCHG mem, reg XCHG reg, reg</p>	$(temp) \leftarrow (dest)$ $(dest) \leftarrow (src)$ $(src) \leftarrow (temp)$	AF – CF – DF – IF – OF – PF – SF – TF – ZF –

NOTE: The three symbols used in the Flags Affected column are defined as follows:
 – the contents of the flag remain unchanged after the instruction is executed
 ? the contents of the flag is undefined after the instruction is executed
 ✓ the flag is updated after the instruction is executed

Table C-4. Instruction Set (Continued)

Name	Description	Operation	Flags Affected
XLAT	<p>Translate: <i>XLAT translate-table</i></p> <p>Replaces a byte in the AL register with a byte from a 256-byte, user-coded translation table. Register BX is assumed to point to the beginning of the table. The byte in AL is used as an index into the table and is replaced by the byte at the offset in the table corresponding to AL's binary value. The first byte in the table has an offset of 0. For example, if AL contains 5H, and the sixth element of the translation table contains 33H, then AL will contain 33H following the instruction. XLAT is useful for translating characters from one code to another, the classic example being ASCII to EBCDIC or the reverse.</p> <p>Instruction Operands: XLAT src-table</p>	$AL \leftarrow ((BX) + (AL))$	AF – CF – DF – IF – OF – PF – SF – TF – ZF –
XOR	<p>Exclusive Or: <i>XOR dest, src</i></p> <p>Performs the logical "exclusive or" of the two operands and returns the result to the destination operand. A bit in the result is set if the corresponding bits of the original operands contain opposite values (one is set, the other is cleared); otherwise the result bit is cleared.</p> <p>Instruction Operands: XOR reg, reg XOR reg, mem XOR mem, reg XOR accum, immed XOR reg, immed XOR mem, immed</p>	$(dest) \leftarrow (dest) \text{ xor } (src)$ $(CF) \leftarrow 0$ $(OF) \leftarrow 0$	AF ? CF ✓ DF – IF – OF ✓ PF ✓ SF ✓ TF – ZF ✓

NOTE: The three symbols used in the Flags Affected column are defined as follows:
 – the contents of the flag remain unchanged after the instruction is executed
 ? the contents of the flag is undefined after the instruction is executed
 ✓ the flag is updated after the instruction is executed





D

**Instruction Set
Opcodes and Clock
Cycles**



APPENDIX D

INSTRUCTION SET OPCODES AND CLOCK CYCLES

This appendix provides reference information for the 80C186 Modular Core family instruction set. Table D-1 defines the variables used in Table D-2, which lists the instructions with their formats and execution times. Table D-3 is a guide for decoding machine instructions. Table D-4 is a guide for encoding instruction mnemonics, and Table D-5 defines Table D-4 abbreviations.

Table D-1. Operand Variables

Variable	Description
mod	<i>mod</i> and <i>r/m</i> determine the Effective Address (EA).
<i>r/m</i>	<i>r/m</i> and <i>mod</i> determine the Effective Address (EA).
reg	<i>reg</i> represents a register.
MMM	<i>MMM</i> and <i>PPP</i> are opcodes to the math coprocessor.
PPP	<i>PPP</i> and <i>MMM</i> are opcodes to the math coprocessor.
TTT	<i>TTT</i> defines which shift or rotate instruction is executed.

<i>r/m</i>	EA Calculation
0 0 0	(BX) + (SI) + DISP
0 0 1	(BX) + (DI) + DISP
0 1 0	(BP) + (SI) + DISP
0 1 1	(BP) + (DI) + DISP
1 0 0	(SI) + DISP
1 0 1	(DI) + DISP
1 1 0	(BP) + DISP, if mod \neq 00 disp-high:disp-low, if mod = 00
1 1 1	(BX) + DISP

mod	Effect on EA Calculation
0 0	if <i>r/m</i> \neq 10, DISP = 0; disp-low and disp-high are absent
0 0	if <i>r/m</i> = 110, EA = disp-high:disp-low
0 1	DISP = disp-low, sign-extended to 16 bits; disp-high is absent
1 0	DISP = disp-high:disp-low
1 1	<i>r/m</i> is treated as a reg field

DISP follows the second byte of the instruction (before any required data).

Physical addresses of operands addressed by the BP register are computed using the SS segment register. Physical addresses of destination operands of string primitives (addressed by the DI register) are computed using the ES segment register, which cannot be overridden.

reg	16-bit (w=1)	8-bit (w=0)
0 0 0	AX	AL
0 0 1	CX	CL
0 1 0	DX	DL
0 1 1	BP	BL
1 0 0	SP	AH
1 0 1	BP	CH
1 1 0	SI	DH
1 1 1	DI	BH

TTT	Instruction
0 0 0	ROL
0 0 1	ROR
0 1 0	RCL
0 1 1	RCR
1 0 0	SHL/SAL
1 0 1	SHR
1 1 0	—
1 1 1	SAR

Table D-2. Instruction Set Summary

Function	Format				Clocks	Notes
DATA TRANSFER INSTRUCTIONS						
MOV = Move						
register to register/memory	1 0 0 0 1 0 0 w	mod reg r/m			2/12	
register/memory to register	1 0 0 0 1 0 1 w	mod reg r/m			2/9	
immediate to register/memory	1 1 0 0 0 1 1 w	mod 000 r/m	data	data if w=1	12/13	(1)
immediate to register	1 0 1 1 w reg	data	data if w=1		3/4	(1)
memory to accumulator	1 0 1 0 0 0 0 w	addr-low	addr-high		9	
accumulator to memory	1 0 1 0 0 0 1 w	addr-low	addr-high		8	
register/memory to segment register	1 0 0 0 1 1 1 0	mod 0 reg r/m			2/9	
segment register to register/memory	1 0 0 0 1 1 0 0	mod 0 reg r/m			2/11	
PUSH = Push						
memory	1 1 1 1 1 1 1 1	mod 110 r/m			16	
register	0 1 0 1 0 reg				10	
segment register	0 0 0 reg 1 1 0				9	
immediate	0 1 1 0 1 0 s 0	data	data if s=0		10	
POP = Pop						
memory	1 0 0 0 1 1 1 1	mod 000 r/m			20	
register	0 1 0 1 1 reg				10	
segment register	0 0 0 reg 1 1 1	(reg ?01)			8	
PUSHA = Push all	0 1 1 0 0 0 0 0				36	
POPA = Pop all	0 1 1 0 0 0 0 1				51	
XCHG = Exchange						
register/memory with register	1 0 0 0 0 1 1 w	mod reg r/m			4/17	
register with accumulator	1 0 0 1 0 reg				3	
XLAT = Translate byte to AL	1 1 0 1 0 1 1 1				11	
IN = Input from						
fixed port	1 1 1 0 0 1 0 w	port			10	
variable port	1 1 1 0 1 1 0 w				8	
OUT = Output from						
fixed port	1 1 1 0 0 1 0 w	port			9	
variable port	1 1 1 0 1 1 0 w				7	

NOTES:

1. Clock cycles are given for 8-bit/16-bit operations.
2. Clock cycles are given for jump not taken/jump taken.
3. Clock cycles are given for interrupt taken/interrupt not taken.
4. If TEST = 0

Shading indicates additions and enhancements to the 8086/8088 instruction set. See Appendix A, "80C186 Instruction Set Additions and Extensions," for details.

Table D-2. Instruction Set Summary (Continued)

Function	Format				Clocks	Notes
DATA TRANSFER INSTRUCTIONS (Continued)						
LEA = Load EA to register	1 0 0 0 1 1 0 1	mod reg r/m			6	
LDS = Load pointer to DS	1 1 0 0 0 1 0 1	mod reg r/m	(mod ?11)		18	
LES = Load pointer to ES	1 1 0 0 0 1 0 0	mod reg r/m	(mod ?11)		18	
ENTER = Build stack frame	1 1 0 0 1 0 0 0	data-low	data-high	L		
L = 0					15	
L = 1					25	
L > 1					22+16(n-1)	
LEAVE = Tear down stack frame	1 1 0 0 1 0 0 1				8	
LAHF = Load AH with flags	1 0 0 1 1 1 1 1				2	
SAHF = Store AH into flags	1 0 0 1 1 1 1 0				3	
PUSHF = Push flags	1 0 0 1 1 1 0 0				9	
POPF = Pop flags	1 0 0 1 1 1 0 1				8	
ARITHMETIC INSTRUCTIONS						
ADD = Add						
reg/memory with register to either	0 0 0 0 0 d w	mod reg r/m			3/10	
immediate to register/memory	1 0 0 0 0 s w	mod 000 r/m	data	data if sw=01	4/16	
immediate to accumulator	0 0 0 0 0 1 0 w	data	data if w=1		3/4	(1)
ADC = Add with carry						
reg/memory with register to either	0 0 0 1 0 0 d w	mod reg r/m			3/10	
immediate to register/memory	1 0 0 0 0 s w	mod 010 r/m	data	data if sw=01	4/16	
immediate to accumulator	0 0 0 1 0 1 0 w	data	data if w=1		3/4	(1)
INC = Increment						
register/memory	1 1 1 1 1 1 1 w	mod 000 r/m			3/15	
register	0 1 0 0 0 reg				3	
AAA = ASCII adjust for addition	0 0 1 1 0 1 1 1				8	
DAA = Decimal adjust for addition	0 0 1 0 0 1 1 1				4	

NOTES:

1. Clock cycles are given for 8-bit/16-bit operations.
2. Clock cycles are given for jump not taken/jump taken.
3. Clock cycles are given for interrupt taken/interrupt not taken.
4. If TEST = 0

Shading indicates additions and enhancements to the 8086/8088 instruction set. See Appendix A, "80C186 Instruction Set Additions and Extensions," for details.

Table D-2. Instruction Set Summary (Continued)

Function	Format	Clocks	Notes
ARITHMETIC INSTRUCTIONS (Continued)			
SUB = Subtract			
reg/memory with register to either	0 0 1 0 1 0 d w mod reg r/m	3/10	
immediate from register/memory	1 0 0 0 0 0 s w mod 101 r/m data data if sw=01	4/16	
immediate from accumulator	0 0 0 1 1 1 0 w data data if w=1	3/4	(1)
SBB = Subtract with borrow			
reg/memory with register to either	0 0 0 1 1 0 d w mod reg r/m	3/10	
immediate from register/memory	1 0 0 0 0 0 s w mod 011 r/m data data if sw=01	4/16	
immediate from accumulator	0 0 0 1 1 1 0 w data data if w=1	3/4	(1)
DEC = Decrement			
register/memory	1 1 1 1 1 1 1 w mod 001 r/m	3/15	
register	0 1 0 0 1 reg	3	
NEG = Change sign			
	1 1 1 1 0 1 1 w mod reg r/m	3	
CMP = Compare			
register/memory with register	0 0 1 1 1 0 1 w mod reg r/m	3/10	
register with register/memory	0 0 1 1 1 0 0 w mod reg r/m	3/10	
immediate with register/memory	1 0 0 0 0 0 s w mod 111 r/m data data if sw=01	3/10	
immediate with accumulator	0 0 1 1 1 1 0 w data data if w=1	3/4	(1)
AAS = ASCII adjust for subtraction			
	0 0 1 1 1 1 1 1	7	
DAS = Decimal adjust for subtraction			
	0 0 1 0 1 1 1 1	4	
MUL = multiply (unsigned)			
register-byte	1 1 1 1 0 1 1 w mod 100 r/m	26-28	
register-word		35-37	
memory-byte		32-34	
memory-word		41-43	
IMUL = Integer multiply (signed)			
register-byte	1 1 1 1 0 1 1 w mod 101 r/m	25-28	
register-word		34-37	
memory-byte		31-34	
memory-word		40-43	
integer immediate multiply (signed)	0 1 1 0 1 0 s 1 mod reg r/m data data if s=0	22-25/ 29-32	

NOTES:

1. Clock cycles are given for 8-bit/16-bit operations.
2. Clock cycles are given for jump not taken/jump taken.
3. Clock cycles are given for interrupt taken/interrupt not taken.
4. If **TEST** = 0

Shading indicates additions and enhancements to the 8086/8088 instruction set. See Appendix A, "80C186 Instruction Set Additions and Extensions," for details.

Table D-2. Instruction Set Summary (Continued)

Function	Format	Clocks	Notes
ARITHMETIC INSTRUCTIONS (Continued)			
AAM = ASCII adjust for multiply	1 1 0 1 0 1 0 0 0 0 0 0 1 0 1 0	19	
DIV = Divide (unsigned)	1 1 1 1 0 1 1 w mod 110 r/m		
register-byte		29	
register-word		38	
memory-byte		35	
memory-word		44	
IDIV = Integer divide (signed)	1 1 1 1 0 1 1 w mod 111 r/m		
register-byte		29	
register-word		38	
memory-byte		35	
memory-word		44	
AAD = ASCII adjust for divide	1 1 0 1 0 1 0 1 0 0 0 0 1 0 1 0	15	
CBW = Convert byte to word	1 0 0 1 1 0 0 0	2	
CWD = Convert word to double-word	1 0 0 1 1 0 0 1	4	
BIT MANIPULATION INSTRUCTIONS			
NOT = Invert register/memory	1 1 1 1 0 1 1 w mod 010 r/m	3	
AND = And			
reg/memory and register to either	0 0 1 0 0 0 d w mod reg r/m	3/10	
immediate to register/memory	1 0 0 0 0 0 0 w mod 100 r/m data data if w=1	4/16	
immediate to accumulator	0 0 1 0 0 1 0 w data data if w=1	3/4	(1)
OR = Or			
reg/memory and register to either	0 0 0 0 1 0 d w mod reg r/m	3/10	
immediate to register/memory	1 0 0 0 0 0 0 w mod 001 r/m data data if w=1	4/10	
immediate to accumulator	0 0 0 0 1 1 0 w data data if w=1	3/4	(1)
XOR = Exclusive or			
reg/memory and register to either	0 0 1 1 0 0 d w mod reg r/m	3/10	
immediate to register/memory	1 0 0 0 0 0 0 w mod 110 r/m data data if w=1	4/10	
immediate to accumulator	0 0 1 1 0 1 0 w data data if w=1	3/4	(1)

NOTES:

1. Clock cycles are given for 8-bit/16-bit operations.
2. Clock cycles are given for jump not taken/jump taken.
3. Clock cycles are given for interrupt taken/interrupt not taken.
4. If TEST = 0

Shading indicates additions and enhancements to the 8086/8088 instruction set. See Appendix A, "80C186 Instruction Set Additions and Extensions," for details.

Table D-2. Instruction Set Summary (Continued)

Function	Format				Clocks	Notes
BIT MANIPULATION INSTRUCTIONS (Continued)						
TEST = And function to flags, no result						
register/memory and register	1 0 0 0 0 1 0 w	mod reg r/m			3/10	
immediate data and register/memory	1 1 1 1 0 1 1 w	mod 000 r/m	data	data if w=1	4/10	
immediate data and accumulator	1 0 1 0 1 0 0 w	data	data if w=1		3/4	(1)
Shifts/Rotates						
register/memory by 1	1 1 0 1 0 0 0 w	mod TTT r/m			2/15	
register/memory by CL	1 1 0 1 0 0 1 w	mod TTT r/m			5+n/17+n	
register/memory by Count	1 1 0 0 0 0 0 w	mod TTT r/m	count		5+n/17+n	
STRING MANIPULATION INSTRUCTIONS						
MOVS = Move byte/word	1 0 1 0 0 1 0 w				14	
INS = Input byte/word from DX port	0 1 1 0 1 1 0 w				14	
OUTS = Output byte/word to DX port	0 1 1 0 1 1 1 w				14	
CMPS = Compare byte/word	1 0 1 0 0 1 1 w				22	
SCAS = Scan byte/word	1 0 1 0 1 1 1 w				15	
LODS = Load byte/word to AL/AX	1 0 1 0 1 1 0 w				12	
STOS = Store byte/word from AL/AX	1 0 1 0 1 0 1 w				10	
Repeated by count in CX:						
MOVS = Move byte/word	1 1 1 1 0 0 1 0	1 0 1 0 0 1 0 w			8+8n	
INS = Input byte/word from DX port	1 1 1 1 0 0 1 0	0 1 1 0 1 1 0 w			8-8n	
OUTS = Output byte/word to DX port	1 1 1 1 0 0 1 0	0 1 1 0 1 1 1 w			8+8n	
CMPS = Compare byte/word	1 1 1 1 0 0 1 z	1 0 1 0 0 1 1 w			5+22n	
SCAS = Scan byte/word	1 1 1 1 0 0 1 z	1 0 1 0 1 1 1 w			5+15n	
LODS = Load byte/word to AL/AX	1 1 1 1 0 0 1 0	0 1 0 1 0 0 1 w			6+11n	
STOS = Store byte/word from AL/AX	1 1 1 1 0 1 0 0	0 1 0 1 0 0 1 w			6+9n	

NOTES:

1. Clock cycles are given for 8-bit/16-bit operations.
2. Clock cycles are given for jump not taken/jump taken.
3. Clock cycles are given for interrupt taken/interrupt not taken.
4. If **TEST** = 0

Shading indicates additions and enhancements to the 8086/8088 instruction set. See Appendix A, "80C186 Instruction Set Additions and Extensions," for details.

Table D-2. Instruction Set Summary (Continued)

Function	Format	Clocks	Notes
PROGRAM TRANSFER INSTRUCTIONS			
Conditional Transfers — jump if:			
JE/JZ = equal/zero	0 1 1 1 0 1 0 0 disp	4/13	(2)
JL/JNGE = less/not greater or equal	0 1 1 1 1 1 0 0 disp	4/13	(2)
JLE/JNG = less or equal/not greater	0 1 1 1 1 1 1 0 disp	4/13	(2)
JB/JNAE = below/not above or equal	0 1 1 1 0 0 1 0 disp	4/13	(2)
JC = carry	0 1 1 1 0 0 1 0 disp	4/13	(2)
JBE/JNA = below or equal/not above	0 1 1 1 0 1 1 0 disp	4/13	(2)
JP/JPE = parity/parity even	0 1 1 1 1 0 1 0 disp	4/13	(2)
JO = overflow	0 1 1 1 0 0 0 0 disp	4/13	(2)
JS = sign	0 1 1 1 1 0 0 0 disp	4/13	(2)
JNE/JNZ = not equal/not zero	0 1 1 1 0 1 0 1 disp	4/13	(2)
JNL/JGE = not less/greater or equal	0 1 1 1 1 1 0 1 disp	4/13	(2)
JNLE/JG = not less or equal/greater	0 1 1 1 1 1 1 1 disp	4/13	(2)
JNB/JAE = not below/above or equal	0 1 1 1 0 0 1 1 disp	4/13	(2)
JNC = not carry	0 1 1 1 0 0 1 1 disp	4/13	(2)
JNBE/JA = not below or equal/above	0 1 1 1 0 1 1 1 disp	4/13	(2)
JNP/JPO = not parity/parity odd	0 1 1 1 1 0 1 1 disp	4/13	(2)
JNO = not overflow	0 1 1 1 0 0 0 1 disp	4/13	(2)
JNS = not sign	0 1 1 1 1 0 0 1 disp	5/15	(2)
Unconditional Transfers			
CALL = Call procedure			
direct within segment	1 1 1 0 1 0 0 0 disp-low disp-high	15	
reg/memory indirect within segment	1 1 1 1 1 1 1 1 mod 010 r/m	13/19	
indirect intersegment	1 1 1 1 1 1 1 1 mod 011 r/m (mod ?11)	38	
direct intersegment	1 0 0 1 1 0 1 0 segment offset	23	
	selector		

NOTES:

1. Clock cycles are given for 8-bit/16-bit operations.
2. Clock cycles are given for jump not taken/jump taken.
3. Clock cycles are given for interrupt taken/interrupt not taken.
4. If **TEST** = 0

Shading indicates additions and enhancements to the 8086/8088 instruction set. See Appendix A, "80C186 Instruction Set Additions and Extensions," for details.

Table D-2. Instruction Set Summary (Continued)

Function	Format	Clocks	Notes
PROGRAM TRANSFER INSTRUCTIONS (Continued)			
RET = Return from procedure			
within segment	1 1 0 0 0 0 1 1	16	
within segment adding immed to SP	1 1 0 0 0 0 1 0	data-low	data-high
intersegment	1 1 0 0 1 0 1 1		
intersegment adding immed to SP	1 1 0 0 1 0 1 0	data-low	data-high
JMP = Unconditional jump			
short/long	1 1 1 0 1 0 1 1	disp-low	
direct within segment	1 1 1 0 1 0 0 1	disp-low	disp-high
reg/memory indirect within segment	1 1 1 1 1 1 1 1	mod 100 r/m	
indirect intersegment	1 1 1 1 1 1 1 1	mod 101 r/m	(mod ?11)
direct intersegment	1 1 1 0 1 0 1 0	segment offset	
		selector	
Iteration Control			
LOOP = Loop CX times	1 1 1 0 0 0 1 0	disp	6/16 (2)
LOOPZ/LOOPE = Loop while zero/equal	1 1 1 0 0 0 0 1	disp	5/16 (2)
LOOPNZ/LOOPNE = Loop while not zero/not equal	1 1 1 0 0 0 0 0	disp	5/16 (2)
JCXZ = Jump if CX = zero	1 1 1 0 0 0 1 1	disp	6/16 (2)
Interrupts			
INT = Interrupt			
Type specified	1 1 0 0 1 1 0 1	type	47
Type 3	1 1 0 0 1 1 0 0		45
INTO = Interrupt on overflow	1 1 0 0 1 1 1 0		48/4 (3)
BOUND = Detect value out of range	0 1 1 0 0 0 1 0	mod reg r/m	33-35
IRET = Interrupt return	1 1 1 0 0 1 1 1 1		28

NOTES:

1. Clock cycles are given for 8-bit/16-bit operations.
2. Clock cycles are given for jump not taken/jump taken.
3. Clock cycles are given for interrupt taken/interrupt not taken.
4. If TEST = 0

Shading indicates additions and enhancements to the 8086/8088 instruction set. See Appendix A, "80C186 Instruction Set Additions and Extensions," for details.

Table D-2. Instruction Set Summary (Continued)

Function	Format	Clocks	Notes	
PROCESSOR CONTROL INSTRUCTIONS				
CLC = Clear carry	1 1 1 1 1 0 0 0	2	(4)	
CMC = Complement carry	1 1 1 1 0 1 0 1	2		
STC = Set carry	1 1 1 1 1 0 0 1	2		
CLD = Clear direction	1 1 1 1 1 1 0 0	2		
STD = Set direction	1 1 1 1 1 1 0 1	2		
CLI = Clear interrupt	1 1 1 1 1 0 1 0	2		
STI = Set interrupt	1 1 1 1 1 0 1 1	2		
HLT = Halt	1 1 1 1 0 1 0 0	2		
WAIT = Wait	1 0 0 1 1 0 1 1	6		
LOCK = Bus lock prefix	1 1 1 1 0 0 0 0	2		
ESC = Math coprocessor escape	1 1 0 1 1 M M M	6		mod PPP r/m
NOP = No operation	1 0 0 1 0 0 0 0	3		
SEGMENT OVERRIDE PREFIX				
CS	0 0 1 0 1 1 1 0	2		
SS	0 0 1 1 0 1 1 0	2		
DS	0 0 1 1 1 1 1 0	2		
ES	0 0 1 0 0 1 1 0	2		

NOTES:

1. Clock cycles are given for 8-bit/16-bit operations.
2. Clock cycles are given for jump not taken/jump taken.
3. Clock cycles are given for interrupt taken/interrupt not taken.
4. If TEST = 0

Shading indicates additions and enhancements to the 8086/8088 instruction set. See Appendix A, "80C186 Instruction Set Additions and Extensions," for details.

Table D-3. Machine Instruction Decoding Guide

Byte 1		Byte 2	Bytes 3–6	ASM-86 Instruction Format	
Hex	Binary				
00	0000 0000	mod reg r/m	(disp-lo),(disp-hi)	add	reg8/mem8, reg8
01	0000 0001	mod reg r/m	(disp-lo),(disp-hi)	add	reg16/mem16,reg16
02	0000 0010	mod reg r/m	(disp-lo),(disp-hi)	add	reg8,reg8/mem8
03	0000 0011	mod reg r/m	(disp-lo),(disp-hi)	add	reg16,reg16/mem16
04	0000 0100	data-8		add	AL,immed8
05	0000 0101	data-lo	data-hi	add	AX,immed16
06	0000 0110			push	ES
07	0000 0111			pop	ES
08	0000 0100	mod reg r/m	(disp-lo),(disp-hi)	or	reg8/mem8,reg8

Table D-3. Machine Instruction Decoding Guide (Continued)

Byte 1		Byte 2	Bytes 3–6	ASM-86 Instruction Format	
Hex	Binary				
09	0000 1001	mod reg r/m	(disp-lo),(disp-hi)	or	reg16/mem16,reg16
0A	0000 1010	mod reg r/m	(disp-lo),(disp-hi)	or	reg8,reg8/mem8
0B	0000 1011	mod reg r/m	(disp-lo),(disp-hi)	or	reg16,reg16/mem16
0C	0000 1100	data-8		or	AL, imm8
0D	0000 1101	data-lo	data-hi	or	AX,imm16
0E	0000 1110			push	CS
0F	0000 1111			—	
10	0001 0000	mod reg r/m	(disp-lo),(disp-hi)	adc	reg8/mem8,reg8
11	0001 0001	mod reg r/m	(disp-lo),(disp-hi)	adc	reg16/mem16,reg16
12	0001 0010	mod reg r/m	(disp-lo),(disp-hi)	adc	reg8,reg8/mem8
13	0001 0011	mod reg r/m	(disp-lo),(disp-hi)	adc	reg16,reg16/mem16
14	0001 0100	data-8		adc	AL,imm8
15	0001 0101	data-lo	data-hi	adc	AX,imm16
16	0001 0110			push	SS
17	0001 0111			pop	SS
18	0001 1000	mod reg r/m	(disp-lo),(disp-hi)	sbb	reg8/mem8,reg8
19	0001 1001	mod reg r/m	(disp-lo),(disp-hi)	sbb	reg16/mem16,reg16
1A	0001 1010	mod reg r/m	(disp-lo),(disp-hi)	sbb	reg8,reg8/mem8
1B	0001 1011	mod reg r/m	(disp-lo),(disp-hi)	sbb	reg16,reg16/mem16
1C	0001 1100	data-8		sbb	AL,imm8
1D	0001 1101	data-lo	data-hi	sbb	AX,imm16
1E	0001 1110			push	DS
1F	0001 1111			pop	DS
20	0010 0000	mod reg r/m	(disp-lo),(disp-hi)	and	reg8/mem8,reg8
21	0010 0001	mod reg r/m	(disp-lo),(disp-hi)	and	reg16/mem16,reg16
22	0010 0010	mod reg r/m	(disp-lo),(disp-hi)	and	reg8,reg8/mem8
23	0010 0011	mod reg r/m	(disp-lo),(disp-hi)	and	reg16,reg16/mem16
24	0010 0100	data-8		and	AL,imm8
25	0010 0101	data-lo	data-hi	and	AX,imm16
26	0010 0110			ES:	(segment override prefix)
27	0010 0111			daa	
28	0010 1000	mod reg r/m	(disp-lo),(disp-hi)	sub	reg8/mem8,reg8
29	0010 1001	mod reg r/m	(disp-lo),(disp-hi)	sub	reg16/mem16,reg16
2A	0010 1010	mod reg r/m	(disp-lo),(disp-hi)	sub	reg8,reg8/mem8
2B	0010 1011	mod reg r/m	(disp-lo),(disp-hi)	sub	reg16,reg16/mem16
2C	0010 1100	data-8		sub	AL,imm8
2D	0010 1101	data-lo	data-hi	sub	AX,imm16

Table D-3. Machine Instruction Decoding Guide (Continued)

Byte 1		Byte 2	Bytes 3–6	ASM-86 Instruction Format	
Hex	Binary				
2E	0010 1110			DS:	(segment override prefix)
2F	0010 1111			das	
30	0011 0000	mod reg r/m	(disp-lo),(disp-hi)	xor	reg8/mem8,reg8
31	0011 0001	mod reg r/m	(disp-lo),(disp-hi)	xor	reg16/mem16,reg16
32	0011 0010	mod reg r/m	(disp-lo),(disp-hi)	xor	reg8,reg8/mem8
33	0011 0011	mod reg r/m	(disp-lo),(disp-hi)	xor	reg16,reg16/mem16
34	0011 0100	data-8		xor	AL,immed8
35	0011 0101	data-lo	data-hi	xor	AX,immed16
36	0011 0110			SS:	(segment override prefix)
37	0011 0111			aaa	
38	0011 1000	mod reg r/m	(disp-lo),(disp-hi)	xor	reg8/mem8,reg8
39	0011 1001	mod reg r/m	(disp-lo),(disp-hi)	xor	reg16/mem16,reg16
3A	0011 1010	mod reg r/m	(disp-lo),(disp-hi)	xor	reg8,reg8/mem8
3B	0011 1011	mod reg r/m	(disp-lo),(disp-hi)	xor	reg16,reg16/mem16
3C	0011 1100	data-8		xor	AL,immed8
3D	0011 1101	data-lo	data-hi	xor	AX,immed16
3E	0011 1110			DS:	(segment override prefix)
3F	0011 1111			aas	
40	0100 0000			inc	AX
41	0100 0001			inc	CX
42	0100 0010			inc	DX
43	0100 0011			inc	BX
44	0100 0100			inc	SP
45	0100 0101			inc	BP
46	0100 0110			inc	SI
47	0100 0111			inc	DI
48	0100 1000			dec	AX
49	0100 1001			dec	CX
4A	0100 1010			dec	DX
4B	0100 1011			dec	BX
4C	0100 1100			dec	SP
4D	0100 1101			dec	BP
4E	0100 1110			dec	SI
4F	0100 1111			dec	DI
50	0101 0000			push	AX
51	0101 0001			push	CX
52	0101 0010			push	DX

Table D-3. Machine Instruction Decoding Guide (Continued)

Byte 1		Byte 2	Bytes 3–6	ASM-86 Instruction Format	
Hex	Binary				
53	0101 0011			push	BX
54	0101 0100			push	SP
55	0101 0101			push	BP
56	0101 0110			push	SI
57	0101 0111			push	DI
58	0101 1000			pop	AX
59	0101 1001			pop	CX
5A	0101 1010			pop	DX
5B	0101 1011			pop	BX
5C	0101 1100			pop	SP
5D	0101 1101			pop	BP
5E	0101 1110			pop	SI
5F	0101 1111			pop	DI
60	0110 0000			pusha	
61	0110 0001			popa	
62	0110 0010	mod reg r/m		bound	reg16,mem16
63	0110 0011			—	
64	0110 0100			—	
65	0110 0101			—	
66	0110 0110			—	
67	0110 0111			—	
68	0110 1000	data-lo	data-hi	push	immed16
69	0110 1001	mod reg r/m	data-lo, data-hi	imul	immed16
70	0111 0000	IP-inc-8		jo	short-label
71	0111 0001	IP-inc-8		jno	short-label
72	0111 0010	IP-inc-8		jb/jnae/jc	short-label
73	0111 0011	IP-inc-8		jnb/jae/jnc	short-label
74	0111 0100	IP-inc-8		je/jz	short-label
75	0111 0101	IP-inc-8		jne/jnz	short-label
76	0111 0110	IP-inc-8		jbe/jna	short-label
77	0111 0111	IP-inc-8		jnb/ja	short-label
78	0111 1000	IP-inc-8		js	short-label
79	0111 1001	IP-inc-8		jns	short-label
7A	0111 1010	IP-inc-8		jp/jpe	short-label
7B	0111 1011	IP-inc-8		jnp/jpo	short-label
7C	0111 1100	IP-inc-8		jl/jnge	short-label
7D	0111 1101	IP-inc-8		jnl/jge	short-label

Table D-3. Machine Instruction Decoding Guide (Continued)

Byte 1		Byte 2	Bytes 3–6	ASM-86 Instruction Format	
Hex	Binary				
7E	0111 1110	IP-inc-8		jle/jng	short-label
7F	0111 1111	IP-inc-8		jnl/jg	short-label
80	1000 0000	mod 000 r/m	(disp-lo),(disp-hi), data-8	add	reg8/mem8,immed8
		mod 001 r/m	(disp-lo),(disp-hi), data-8	or	reg8/mem8,immed8
		mod 010 r/m	(disp-lo),(disp-hi), data-8	adc	reg8/mem8,immed8
		mod 011 r/m	(disp-lo),(disp-hi), data-8	sbb	reg8/mem8,immed8
		mod 100 r/m	(disp-lo),(disp-hi), data-8	and	reg8/mem8,immed8
		mod 101 r/m	(disp-lo),(disp-hi), data-8	sub	reg8/mem8,immed8
		mod 110 r/m	(disp-lo),(disp-hi), data-8	xor	reg8/mem8,immed8
		mod 111 r/m	(disp-lo),(disp-hi), data-8	cmp	reg8/mem8,immed8
81	1000 0001	mod 000 r/m	(disp-lo),(disp-hi), data-lo,data-hi	add	reg16/mem16,immed16
		mod 001 r/m	(disp-lo),(disp-hi), data-lo,data-hi	or	reg16/mem16,immed16
		mod 010 r/m	(disp-lo),(disp-hi), data-lo,data-hi	adc	reg16/mem16,immed16
		mod 011 r/m	(disp-lo),(disp-hi), data-lo,data-hi	sbb	reg16/mem16,immed16
		mod 100 r/m	(disp-lo),(disp-hi), data-lo,data-hi	and	reg16/mem16,immed16
81	1000 0001	mod 101 r/m	(disp-lo),(disp-hi), data-lo,data-hi	sub	reg16/mem16,immed16
		mod 110 r/m	(disp-lo),(disp-hi), data-lo,data-hi	xor	reg16/mem16,immed16
		mod 111 r/m	(disp-lo),(disp-hi), data-lo,data-hi	cmp	reg16/mem16,immed16
82	1000 0010	mod 000 r/m	(disp-lo),(disp-hi), data-8	add	reg8/mem8,immed8
		mod 001 r/m		—	
		mod 010 r/m	(disp-lo),(disp-hi), data-8	adc	reg8/mem8,immed8
		mod 011 r/m	(disp-lo),(disp-hi), data-8	sbb	reg8/mem8,immed8
		mod 100 r/m		—	
		mod 101 r/m	(disp-lo),(disp-hi), data-8	sub	reg8/mem8,immed8
		mod 110 r/m		—	
		mod 111 r/m	(disp-lo),(disp-hi), data-8	cmp	reg8/mem8,immed8
83	1000 0011	mod 000 r/m	(disp-lo),(disp-hi), data-SX	add	reg16/mem16,immed8
		mod 001 r/m		—	
		mod 010 r/m	(disp-lo),(disp-hi), data-SX	adc	reg16/mem16,immed8
		mod 011 r/m	(disp-lo),(disp-hi), data-SX	sbb	reg16/mem16,immed8
		mod 100 r/m		—	
		mod 101 r/m	(disp-lo),(disp-hi), data-SX	sub	reg16/mem16,immed8
		mod 110 r/m		—	
		mod 111 r/m	(disp-lo),(disp-hi), data-SX	cmp	reg16/mem16,immed8
84	1000 0100	mod reg r/m	(disp-lo),(disp-hi)	test	reg8/mem8,reg8
85	1000 0101	mod reg r/m	(disp-lo),(disp-hi)	test	reg16/mem16,reg16
86	1000 0110	mod reg r/m	(disp-lo),(disp-hi)	xchg	reg8,reg8/mem8

Table D-3. Machine Instruction Decoding Guide (Continued)

Byte 1		Byte 2	Bytes 3–6	ASM-86 Instruction Format	
Hex	Binary				
87	1000 0111	mod reg r/m	(disp-lo),(disp-hi)	xchg	reg16,reg16/mem16
88	1000 0100	mod reg r/m	(disp-lo),(disp-hi)	mov	reg8/mem8,reg8
89	1000 1001	mod reg r/m	(disp-lo),(disp-hi)	mov	reg16/mem16,reg16
8A	1000 1010	mod reg r/m	(disp-lo),(disp-hi)	mov	reg8,reg8/mem8
8B	1000 1011	mod reg r/m	(disp-lo),(disp-hi)	mov	reg16,reg16/mem16
8C	1000 1100	mod OSR r/m	(disp-lo),(disp-hi)	mov	reg16/mem16,SEGREG
		mod 1 - r/m		—	
8D	1000 1101	mod reg r/m	(disp-lo),(disp-hi)	lea	reg16,mem16
8E	1000 1110	mod OSR r/m	(disp-lo),(disp-hi)	mov	SEGREG,reg16/mem16
		mod 1 - r/m		—	
8F	1000 1111			pop	mem16
90	1001 0000			nop	(xchg AX,AX)
91	1001 0001			xchg	AX,CX
92	1001 0010			xchg	AX,DX
93	1001 0011			xchg	AX,BX
94	1001 0100			xchg	AX,SP
95	1001 0101			xchg	AX,BP
96	1001 0110			xchg	AX,SI
97	1001 0111			xchg	AX,DI
98	1001 1000			cbw	
99	1001 1001			cwd	
9A	1001 1010	disp-lo	disp-hi,seg-lo,seg-hi	call	far-proc
9B	1001 1011			wait	
9C	1001 1100			pushf	
9D	1001 1101			popf	
9E	1001 1110			sahf	
9F	1001 1111			lahf	
A0	1010 0000	addr-lo	addr-hi	mov	AL,mem8
A1	1010 0001	addr-lo	addr-hi	mov	AX,mem16
A2	1010 0010	addr-lo	addr-hi	mov	mem8,AL
A3	1010 0011	addr-lo	addr-hi	mov	mem16,AL
A4	1010 0100			movs	dest-str8,src-str8
A5	1010 0101			movs	dest-str16,src-str16
A6	1010 0110			cmps	dest-str8,src-str8
A7	1010 0111			cmps	dest-str16,src-str16
A8	1010 1000	data-8		test	AL,immed8
A9	1010 1001	data-lo	data-hi	test	AX,immed16

Table D-3. Machine Instruction Decoding Guide (Continued)

Byte 1		Byte 2	Bytes 3–6	ASM-86 Instruction Format	
Hex	Binary				
AA	1010 1010			stos	dest-str8
AB	1010 1011			stos	dest-str16
AC	1010 1100			lods	src-str8
AD	1010 1101			lods	src-str16
AE	1010 1110			scas	dest-str8
AF	1010 1111			scas	dest-str16
B0	1011 0000	data-8		mov	AL,immed8
B1	1011 0001	data-8		mov	CL,immed8
B2	1011 0010	data-8		mov	DL,immed8
B3	1011 0011	data-8		mov	BL,immed8
B4	1011 0100	data-8		mov	AH,immed8
B5	1011 0101	data-8		mov	CH,immed8
B6	1011 0110	data-8		mov	DH,immed8
B7	1011 0111	data-8		mov	BH,immed8
B8	1011 1000	data-lo	data-hi	mov	AX,immed16
B9	1011 1001	data-lo	data-hi	mov	CX,immed16
BA	1011 1010	data-lo	data-hi	mov	DX,immed16
BB	1011 1011	data-lo	data-hi	mov	BX,immed16
BC	1011 1100	data-lo	data-hi	mov	SP,immed16
BD	1011 1101	data-lo	data-hi	mov	BP,immed16
BE	1011 1110	data-lo	data-hi	mov	SI,immed16
BF	1011 1111	data-lo	data-hi	mov	DI,immed16
C0	1100 0000	mod 000 r/m	data-8	rol	reg8/mem8, immed8
		mod 001 r/m	data-8	ror	reg8/mem8, immed8
		mod 010 r/m	data-8	rcl	reg8/mem8, immed8
		mod 011 r/m	data-8	rcr	reg8/mem8, immed8
		mod 100 r/m	data-8	shl/sal	reg8/mem8, immed8
		mod 101 r/m	data-8	shr	reg8/mem8, immed8
		mod 110 r/m		—	
		mod 111 r/m	data-8	sar	reg8/mem8, immed8
C1	1100 0001	mod 000 r/m	data-8	rol	reg16/mem16, immed8
		mod 001 r/m	data-8	ror	reg16/mem16, immed8
		mod 010 r/m	data-8	rcl	reg16/mem16, immed8
		mod 011 r/m	data-8	rcr	reg16/mem16, immed8
		mod 100 r/m	data-8	shl/sal	reg16/mem16, immed8
		mod 101 r/m	data-8	shr	reg16/mem16, immed8
		mod 110 r/m		—	
		mod 111 r/m			

Table D-3. Machine Instruction Decoding Guide (Continued)

Byte 1		Byte 2	Bytes 3–6	ASM-86 Instruction Format	
Hex	Binary				
		mod 111 r/m	data-8	sar	reg16/mem16, immed8
C2	1100 0010	data-lo	data-hi	ret	immed16 (intrasegment)
C3	1100 0011			ret	(intrasegment)
C4	1100 0100	mod reg r/m	(disp-lo),(disp-hi)	les	reg16,mem16
C5	1100 0101	mod reg r/m	(disp-lo),(disp-hi)	lds	reg16,mem16
C6	1100 0110	mod 000 r/m	(disp-lo),(disp-hi),data-8	mov	mem8,immed8
		mod 001 r/m		—	
		mod 010 r/m		—	
		mod 011 r/m		—	
		mod 100 r/m		—	
		mod 101 r/m		—	
		mod 110 r/m		—	
C6	1100 0110	mod 111 r/m		—	
C7	1100 0111	mod 000 r/m	(disp-lo),(disp-hi),data-lo,data-hi	mov	mem16,immed16
		mod 001 r/m		—	
		mod 010 r/m		—	
		mod 011 r/m		—	
		mod 100 r/m		—	
		mod 101 r/m		—	
		mod 110 r/m		—	
		mod 111 r/m		—	
C8	1100 1000	data-lo	data-hi, level	enter	immed16, immed8
C9	1100 1001			leave	
CA	1100 1010	data-lo	data-hi	ret	immed16 (intersegment)
CB	1100 1011			ret	(intersegment)
CC	1100 1100			int	3
CD	1100 1101	data-8		int	immed8
CE	1100 1110			into	
CF	1100 1111			iret	
D0	1101 0000	mod 000 r/m	(disp-lo),(disp-hi)	rol	reg8/mem8,1
		mod 001 r/m	(disp-lo),(disp-hi)	ror	reg8/mem8,1
		mod 010 r/m	(disp-lo),(disp-hi)	rcl	reg8/mem8,1
		mod 011 r/m	(disp-lo),(disp-hi)	rcr	reg8/mem8,1
		mod 100 r/m	(disp-lo),(disp-hi)	sal/shl	reg8/mem8,1
		mod 101 r/m	(disp-lo),(disp-hi)	shr	reg8/mem8,1
		mod 110 r/m		—	
		mod 111 r/m	(disp-lo),(disp-hi)	sar	reg8/mem8,1

Table D-3. Machine Instruction Decoding Guide (Continued)

Byte 1		Byte 2	Bytes 3–6	ASM-86 Instruction Format	
Hex	Binary				
D1	1101 0001	mod 000 r/m	(disp-lo),(disp-hi)	rol	reg16/mem16,1
		mod 001 r/m	(disp-lo),(disp-hi)	ror	reg16/mem16,1
D1	1101 0001	mod 010 r/m	(disp-lo),(disp-hi)	rcl	reg16/mem16,1
		mod 011 r/m	(disp-lo),(disp-hi)	rcr	reg16/mem16,1
		mod 100 r/m	(disp-lo),(disp-hi)	sal/shl	reg16/mem16,1
		mod 101 r/m	(disp-lo),(disp-hi)	shr	reg16/mem16,1
		mod 110 r/m		—	
		mod 111 r/m	(disp-lo),(disp-hi)	sar	reg16/mem16,1
D2	1101 0010	mod 000 r/m	(disp-lo),(disp-hi)	rol	reg8/mem8,CL
		mod 001 r/m	(disp-lo),(disp-hi)	ror	reg8/mem8,CL
		mod 010 r/m	(disp-lo),(disp-hi)	rcl	reg8/mem8,CL
		mod 011 r/m	(disp-lo),(disp-hi)	rcr	reg8/mem8,CL
		mod 100 r/m	(disp-lo),(disp-hi)	sal/shl	reg8/mem8,CL
		mod 101 r/m	(disp-lo),(disp-hi)	shr	reg8/mem8,CL
		mod 110 r/m		—	
		mod 111 r/m	(disp-lo),(disp-hi)	sar	reg8/mem8,CL
D3	1101 0011	mod 000 r/m	(disp-lo),(disp-hi)	rol	reg16/mem16,CL
		mod 001 r/m	(disp-lo),(disp-hi)	ror	reg16/mem16,CL
		mod 010 r/m	(disp-lo),(disp-hi)	rcl	reg16/mem16,CL
		mod 011 r/m	(disp-lo),(disp-hi)	rcr	reg16/mem16,CL
		mod 100 r/m	(disp-lo),(disp-hi)	sal/shl	reg16/mem16,CL
		mod 101 r/m	(disp-lo),(disp-hi)	shr	reg16/mem16,CL
		mod 110 r/m		—	
		mod 111 r/m	(disp-lo),(disp-hi)	sar	reg16/mem16,CL
D4	1101 0100	0000 1010		aam	
D5	1101 0101	0000 1010		aad	
D6	1101 0110			—	
D7	1101 0111			xlat	source-table
D8	1101 1000	mod 000 r/m	(disp-lo),(disp-hi)	esc	opcode,source
D9	1101 1001	mod 001 r/m	(disp-lo),(disp-hi)	esc	opcode,source
DA	1101 1010	mod 010 r/m	(disp-lo),(disp-hi)	esc	opcode,source
DB	1101 1011	mod 011 r/m	(disp-lo),(disp-hi)	esc	opcode,source
DC	1101 1100	mod 100 r/m	(disp-lo),(disp-hi)	esc	opcode,source
DD	1101 1101	mod 101 r/m	(disp-lo),(disp-hi)	esc	opcode,source
DE	1101 1110	mod 110 r/m	(disp-lo),(disp-hi)	esc	opcode,source
DF	1101 1111	mod 111 r/m	(disp-lo),(disp-hi)	esc	opcode,source
E0	1110 0000	IP-inc-8		loopne/loopnz	short-label

Table D-3. Machine Instruction Decoding Guide (Continued)

Byte 1		Byte 2	Bytes 3–6	ASM-86 Instruction Format	
Hex	Binary				
E1	1110 0001	IP-inc-8		loope/loopz	short-label
E2	1110 0010	IP-inc-8		loop	short-label
E3	1110 0011	IP-inc-8		jcxz	short-label
E4	1110 0100	data-8		in	AL,immed8
E5	1110 0101	data-8		in	AX,immed8
E6	1110 0110	data-8		out	AL,immed8
E7	1110 0111	data-8		out	AX,immed8
E8	1110 1000	IP-inc-lo	IP-inc-hi	call	near-proc
E9	1110 1001	IP-inc-lo	IP-inc-hi	jmp	near-label
EA	1110 1010	IP-lo	IP-hi,CS-lo,CS-hi	jmp	far-label
EB	1110 1011	IP-inc-8		jmp	short-label
EC	1110 1100			in	AL,DX
ED	1110 1101			in	AX,DX
EE	1110 1110			out	AL,DX
EF	1110 1111			out	AX,DX
F0	1111 0000			lock	(prefix)
F1	1111 0001			—	
F2	1111 0010			repne/repnz	
F3	1111 0011			rep/repe/repz	
F4	1111 0100			hlt	
F5	1111 0101			cmc	
F6	1111 0110	mod 000 r/m	(disp-lo),(disp-hi),data-8	test	reg8/mem8,immed8
		mod 001 r/m		—	
		mod 010 r/m	(disp-lo),(disp-hi)	not	reg8/mem8
		mod 011 r/m	(disp-lo),(disp-hi)	neg	reg8/mem8
		mod 100 r/m	(disp-lo),(disp-hi)	mul	reg8/mem8
		mod 101 r/m	(disp-lo),(disp-hi)	imul	reg8/mem8
		mod 110 r/m	(disp-lo),(disp-hi)	div	reg8/mem8
		mod 111 r/m	(disp-lo),(disp-hi)	idiv	reg8/mem8
F7	1111 0111	mod 000 r/m	(disp-lo),(disp-hi),data-lo,data-hi	test	reg16/mem16,immed16
		mod 001 r/m		—	
		mod 010 r/m	(disp-lo),(disp-hi)	not	reg16/mem16
		mod 011 r/m	(disp-lo),(disp-hi)	neg	reg16/mem16
		mod 100 r/m	(disp-lo),(disp-hi)	mul	reg16/mem16
		mod 101 r/m	(disp-lo),(disp-hi)	imul	reg16/mem16
		mod 110 r/m	(disp-lo),(disp-hi)	div	reg16/mem16
		mod 111 r/m	(disp-lo),(disp-hi)	idiv	reg16/mem16

Table D-3. Machine Instruction Decoding Guide (Continued)

Byte 1		Byte 2	Bytes 3–6	ASM-86 Instruction Format	
Hex	Binary				
F8	1111 1000			clc	
F9	1111 1001			stc	
FA	1111 1010			cli	
FB	1111 1011			sti	
FC	1111 1100			cld	
FD	1111 1101			std	
FE	1111 1110	mod 000 r/m	(disp-lo),(disp-hi)	inc	mem16
		mod 001 r/m	(disp-lo),(disp-hi)	dec	mem16
		mod 010 r/m		—	
FE	1111 1110	mod 011 r/m		—	
		mod 100 r/m		—	
		mod 101 r/m		—	
		mod 110 r/m		—	
		mod 111 r/m		—	
FF	1111 1111	mod 000 r/m	(disp-lo),(disp-hi)	inc	mem16
		mod 001 r/m	(disp-lo),(disp-hi)	dec	mem16
		mod 010 r/m	(disp-lo),(disp-hi)	call	reg16/mem16 (intrasegment)
		mod 011 r/m	(disp-lo),(disp-hi)	call	mem16 (intersegment)
		mod 100 r/m	(disp-lo),(disp-hi)	jmp	reg16/mem16 (intrasegment)
		mod 101 r/m	(disp-lo),(disp-hi)	jmp	mem16 (intersegment)
		mod 110 r/m	(disp-lo),(disp-hi)	push	mem16
		mod 111 r/m		—	

Table D-4. Mnemonic Encoding Matrix (Left Half)

	x0	x1	x2	x3	x4	x5	x6	x7
0x	ADD b,f,r/m	ADD w,f,r/m	ADD b,t,r/m	ADD w,t,r/m	ADD b,ia	ADD w,ia	PUSH ES	POP ES
1x	ADC b,f,r/m	ADC w,f,r/m	ADC b,t,r/m	ADC w,t,r/m	ADC b,i	ADC w,i	PUSH SS	POP SS
2x	AND b,f,r/m	AND w,f,r/m	AND b,t,r/m	AND w,t,r/m	AND b,i	AND w,i	SEG =ES	DAA
3x	XOR b,f,r/m	XOR w,f,r/m	XOR b,t,r/m	XOR w,t,r/m	XOR b,i	XOR w,i	SEG =SS	AAA
4x	INC AX	INC CX	INC DX	INC BX	INC SP	INC BP	INC SI	INC DI
5x	PUSH AX	PUSH CX	PUSH DX	PUSH BX	PUSH SP	PUSH BP	PUSH SI	PUSH DI
6x	PUSHA	POPA	BOUND w,f,r/m					
7x	JO	JNO	JB/ JNAE/ JC	JNB/ JAE/ JNC	JE/ JZ	JNE/ JNZ	JBE/ JNA	JNBE/ JA
8x	Immed b,r/m	Immed w,r/m	Immed b,r/m	Immed is,r/m	TEST b,r/m	TEST w,r/m	XCHG b,r/m	XCHG w,r/m
9x	NOP (XCHG) AX	XCHG CX	XCHG DX	XCHG BX	XCHG SP	XCHG BP	XCHG SI	XCHG DI
Ax	MOV m→AL	MOV m→AX	MOV AL→m	MOV AX→m	MOVS	MOVS	CMPS	CMPS
Bx	MOV i→AL	MOV i→CL	MOV i→DL	MOV i→BL	MOV i→AH	MOV i→CH	MOV i→DH	MOV i→BH
Cx	Shift b,i	Shift w,i	RET (i+SP)	RET	LES	LDS	MOV b,i,r/m	MOV w,i,r/m
Dx	Shift b	Shift w	Shift b,v	Shift w,v	AAM	AAD		XLAT
Ex	LOOPNZ/ LOOPNE	LOOPZ/ LOOPE	LOOP	JCXZ	IN	IN	OUT	OUT
Fx	LOCK		REP	REP z	HLT	CMC	Grp1 b,r/m	Grp1 w,r/m

NOTE: Table D-5 defines abbreviations used in this matrix. Shading indicates reserved opcodes.

Table D-4. Mnemonic Encoding Matrix (Right Half)

x8	x9	xA	xB	xC	xD	xE	xF	
OR b,f,r/m	OR w,f,r/m	OR b,t,r/m	OR w,t,r/m	OR b,i	OR w,i	PUSH CS		0x
SBB b,f,r/m	SBB w,f,r/m	SBB b,t,r/m	SBB w,t,r/m	SBB b,i	SBB w,i	PUSH DS	POP DS	1x
SUB b,f,r/m	SUB w,f,r/m	SUB b,t,r/m	SUB w,t,r/m	SUB b,i	SUB w,i	SEG =CS	DAS	2x
CMP b,f,r/m	CMP w,f,r/m	CMP b,t,r/m	CMP w,t,r/m	CMP b,i	CMP w,i	SEG =DS	AAS	3x
DEC AX	DEC CX	DEC DX	DEC BX	DEC SP	DEC BP	DEC SI	DEC DI	4x
POP AX	POP CX	POP DX	POP BX	POP SP	POP BP	POP SI	POP DI	5x
PUSH w,i	IMUL w,i	PUSH b,i	IMUL w,i	INS b	INS w	OUTS b	OUTS w	6x
JS	JNS	JP/ JPE	JNP/ JPO	JL/ JNGE	JNL/ JGE	JLE/ JNG	JNLE/ JG	7x
MOV b,f,r/m	MOV w,f,r/m	MOV b,t,r/m	MOV w,t,r/m	MOV sr,f,r/m	LEA	MOV sr,t,r/m	POP r/m	8x
CBW	CWD	CALL LD	WAIT	PUSHF	POPF	SAHF	LAHF	9x
TEST b,ia	TEST w,ia	STOS	STOS	LODS	LODS	SCAS	SCAS	Ax
MOV i→AX	MOV i→CX	MOV i→DX	MOV i→BX	MOV i→SP	MOV i→BP	MOV i→SI	MOV i→DI	Bx
ENTER	LEAVE	RET l(i+SP)	RET l	INT type 3	INT (any)	INTO	IRET	Cx
ESC 0	ESC 1	ESC 2	ESC 3	ESC 4	ESC 5	ESC 6	ESC 7	Dx
CALL	JMP	JMP	JMP	IN	IN	OUT	OUT	Ex
CLC	STC	CLI	STI	CLS	STD	Grp2 b,r/m	Grp2 w,r/m	Fx

NOTE: Table D-5 defines abbreviations used in this matrix. Shading indicates reserved opcodes.

Table D-5. Abbreviations for Mnemonic Encoding Matrix

Abbr	Definition	Abbr	Definition	Abbr	Definition	Abbr	Definition
b	byte operation	ia	immediate to accumulator	m	memory	t	to CPU register
d	direct	id	indirect	r/m	EA is second byte	v	variable
f	from CPU register	is	immediate byte, sign extended	si	short intrasegment	w	word operation
i	immediate	l	long (intersegment)	sr	segment register	z	zero

Byte 2	Immed	Shift	Grp1	Grp2
mod 000 r/m	ADD	ROL	TEST	INC
mod 001 r/m	OR	ROR	—	DEC
mod 010 r/m	ADC	RCL	NOT	CALL id
mod 011 r/m	SBB	RCR	NEG	CALL i, id
mod 100 r/m	AND	SHL/SAL	MUL	JMP id
mod 101 r/m	SUB	SHR	IMUL	JMP i, id
mod 110 r/m	XOR	—	DIV	PUSH
mod 111 r/m	CMP	SAR	IDIV	—

mod and *r/m* determine the Effective Address (EA) calculation. See Table D-1 for definitions.



Index



- 80C187 Math Coprocessor, 11-2–11-8
 - accessing, 11-10–11-11
 - arithmetic instructions, 11-3–11-4
 - bus cycles, 11-11
 - clocking, 11-10
 - code examples, 11-13–11-16
 - comparison instructions, 11-5
 - constant instructions, 11-6
 - data transfer instructions, 11-3
 - data types, 11-7–11-8
 - design considerations, 11-10–11-11
 - example floating point routine, 11-16
 - exceptions, 11-13
 - I/O port assignments, 11-10
 - initialization example, 11-13–11-16
 - instruction set, 11-2
 - interface, 11-7–11-13
 - and chip-selects, 6-17, 11-11
 - and PCB location, 4-7
 - exception trapping, 11-13
 - generating READY, 11-11
 - processor control instructions, 11-6
 - testing for presence, 11-10
 - transcendental instructions, 11-5
 - 8259A Programmable Interrupt Controllers, 8-1
 - and special fully nested mode, 8-8
 - cascading, 8-7, 8-8
 - interrupt type, 8-9
 - priority structure, 8-8
 - 82C59A Programmable Interrupt Controller
 - interfacing with, 3-25–3-27
- A**
- Address and data bus, 3-1–3-6
 - 16-bit, 3-1–3-5
 - considerations, 3-7
 - 8-bit, 3-5–3-6
 - considerations, 3-7

See also Bus cycles, Data transfers

 - Address bus, *See Address and data bus*
 - Address space, *See Memory space, I/O space*
 - Addressing modes, 2-27–2-36
 - and string instructions, 2-34
 - based, 2-30, 2-31, 2-32
 - based index, 2-34, 2-35
 - direct, 2-29
 - immediate operands, 2-28
 - indexed, 2-32, 2-33
 - indirect, 2-36
 - memory operands, 2-28
 - register indirect, 2-30, 2-31
 - register operands, 2-27
 - AH register, 2-5
 - AL register, 2-5, 2-18, 2-23
 - ApBUILDER software, downloading, 1-5
 - Application BBS, 1-5
 - Architecture
 - CPU block diagram, 2-2
 - device feature comparisons, 1-2
 - family introduction, 1-1
 - overview, 1-1, 2-1
 - ARDY, *See READY*
 - Arithmetic
 - instructions, 2-19–2-20
 - interpretation of 8-bit numbers, 2-20
 - Arithmetic Logic Unit (ALU), 2-1
 - Array bounds trap (Type 5 exception), 2-44
 - ASCII, defined, 2-37
 - Auxiliary Flag (AF), 2-7, 2-9
 - AX register, 2-1, 2-5, 2-18, 2-23, 3-6
- B**
- Base Pointer (BP), *See BP register*
 - BBS, 1-5
 - BCD, defined, 2-37
 - Bit manipulation instructions, 2-21–2-22
 - BOUND instruction, 2-44, A-8
 - BP register, 2-1, 2-13, 2-30, 2-34
 - Breakpoint interrupt (Type 3 exception), 2-44
 - Bulletin board system (BBS), 1-5
 - Bus cycles, 3-20–3-47
 - address/status phase, 3-10–3-12
 - and 80C187, 11-11
 - and CSU, 6-17
 - and Idle mode, 5-13
 - and PCB accesses, 4-4
 - and Powerdown mode, 5-16
 - and T-states, 3-9

- data phase, 3-13
 - HALT cycle, 3-28–3-35
 - and chip-selects, 6-5
 - HALT state, exiting, 3-31–3-35
 - idle states, 3-18
 - instruction prefetch, 3-20
 - interrupt acknowledge (INTA) cycles, 3-6, 3-25–3-26, 8-9
 - and chip-selects, 6-5
 - interrupt acknowledge cycles, 8-29
 - operation, 3-7–3-20
 - priorities, 3-46–3-47, 7-2
 - read cycles, 3-20–3-21
 - refresh cycles, 3-22, 7-4, 7-5
 - control signals, 7-5, 7-6
 - during HOLD, 3-43–3-45, 7-12–7-13
 - wait states, 3-13–3-18
 - write cycles, 3-22–3-25
 - See also Data transfers*
 - Bus hold protocol, 3-41–3-46
 - and CLKOUT, 5-6
 - and CSU, 6-18
 - and Idle mode, 5-14
 - and refresh cycles, 3-43–3-45, 7-12–7-13
 - and reset, 5-9
 - latency, 3-42–3-43
 - Bus Interface Unit (BIU), 2-1, 2-3, 2-11, 3-1–3-47
 - and DMA, 10-8
 - and DRAM refresh requests, 7-4
 - and TCU, 9-1
 - buffering the data bus, 3-36–3-38
 - modifying interface, 3-35–3-38, 3-38
 - relationship to RCU, 7-1
 - synchronizing software and hardware events, 3-38–3-39
 - using a locked bus, 3-39–3-40
 - using multiple bus masters, 3-41–3-46
 - using the queue status signals, 3-40–3-41
 - BX register, 2-1, 2-5, 2-30
- C**
- Carry Flag (CF), 2-7, 2-9
 - Chip-Select Unit (CSU), 6-1
 - and DMA, 10-8
 - and DMA acknowledge signal, 10-22
 - and HALT bus cycles, 3-28
 - and READY, 6-15–6-16
 - and wait states, 6-15–6-16
 - block diagram, 6-3
 - bus cycle decoding, 6-17
 - examples, 6-18–6-22
 - features and benefits, 6-1
 - functional overview, 6-2–6-5
 - programming, 6-6–6-17
 - registers, 6-6–6-12
 - system diagram, 6-19
 - See also Chip selects*
 - Chip-selects
 - activating, 6-5
 - and 80C187 interface, 6-17, 11-11
 - and bus hold protocol, 6-18
 - and DMA acknowledge signal, 10-22
 - and DRAM controllers, 7-1
 - and reserved I/O locations, 6-17
 - initializing, 6-6–6-18
 - methods for generating, 6-1
 - overlapping, 6-16–6-17
 - programming considerations, 6-17
 - start address, 6-17
 - timing, 6-4
 - CL register, 2-5, 2-21, 2-22
 - CLKOUT
 - and bus hold, 5-6
 - and power management modes, 5-6
 - and reset, 5-6
 - Clock divider, 5-19
 - control register, 5-20
 - Clock generator, 5-6–5-10
 - and system reset, 5-6–5-7
 - output, 5-6
 - synchronizing CLKOUT and RESOUT, 5-6–5-7
 - Clock sources, TCU, 9-12
 - Code (programs), *See Software*
 - Code segment, 2-5
 - CompuServe forums, 1-6
 - Counters, *See Timer Counter Unit (TCU)*
 - CPU, block diagram, 2-2
 - Crystal, *See Oscillator*
 - CS register, 2-1, 2-5, 2-6, 2-13, 2-23, 2-39, 2-41
 - Customer service, 1-4
 - CX register, 2-1, 2-5, 2-23, 2-25, 2-26

D

Data, 3-6

Data bus, *See Address and data bus*

Data segment, 2-5

Data sheets, online, 1-6

Data transfers, 3-1–3-6

instructions, 2-18

PCB considerations, 4-5

PSW flag storage formats, 2-19

See also Bus cycles

Data types, 2-37–2-38

DI register, 2-1, 2-5, 2-13, 2-22, 2-23, 2-30, 2-32, 2-34

Digital one-shot, code example, 9-17–9-23

Direct Memory Access (DMA) Unit, 10-1–10-27

and BIU, 10-8

and CSU, 10-8

and PCB, 10-3

arming channel, 10-18

DMA acknowledge signal, 10-2, 10-22

DRQ timing, 10-20

examples, 10-22–10-27

HALT bit, 8-22, 8-23, 10-20

hardware considerations, 10-20–10-22

initialization code, 10-22–10-27

initializing, 10-20

interrupts, 10-8

generating on terminal count, 10-19

introduction, 10-1

latency, 10-21

modules, 10-8–10-9

overview, 10-1–10-10

pointers, programming, 10-10–10-14

priority

channel, 10-8–10-9, 10-19

fixed, 10-8–10-10

rotating, 10-10

programming, 10-17–10-20

arming channel, 10-18

channel priority, 10-19

initializing, 10-20

interrupts, 10-19

suspending transfers, 10-20

synchronization, 10-18

transfer count, 10-18–10-19

programming, pointers, 10-10–10-14

requests, 10-3

external, 10-4

internal, 10-6

software, 10-6

Timer 2, 10-6

selecting source, 10-17

synchronization

destination-synchronized, 10-5

selecting, 10-18

source-synchronized, 10-5

unsynchronized, 10-6

timed DMA transfer example, 10-22–10-27

transfers, 10-1–10-27

count, 10-7

programming, 10-18–10-19

direction, 10-3

rates, 10-21

size, 10-3

selecting, 10-14

suspending, 10-7, 10-20

terminating, 10-7

Direction Flag (DF), 2-7, 2-9, 2-23

Display, defined, A-2

Divide Error trap (Type 0 exception), 2-43

DMA Control Register (DxCON), 10-15

DMA Destination Pointer Register, 10-13, 10-14

DMA Source Pointer Register, 10-11, 10-12

Documents, related, 1-3

DRAM controllers

and wait state control, 7-5

clocked, 7-5

design guidelines, 7-5

unclocked, 7-5

See also Refresh Control Unit

DS register, 2-1, 2-5, 2-6, 2-13, 2-30, 2-34, 2-43

DX register, 2-1, 2-5, 2-36, 3-6

E

Effective Address (EA), 2-13

calculation, 2-28

Emulation mode, 12-1

End-of-Interrupt (EOI)

command, 8-21

register, 8-21, 8-22, 8-27, 8-28

ENTER instruction, A-2

ES register, 2-1, 2-5, 2-6, 2-13, 2-30, 2-34

Escape opcode fault (Type 7 exception), 2-44, 11-2

Exceptions, 2-43–2-44
 priority, 2-46–2-49
 Execution Unit (EU), 2-1, 2-2
 Extra segment, 2-5

F

Fault exceptions, 2-43
 FaxBack service, 1-4
 F-Bus
 and PCB, 4-5
 operation, 4-5
 Flags, *See Processor Status Word (PSW)*
 Floating Point, defined, 2-37

H

HALT bus cycle, *See Bus cycles*
 HOLD/H LDA protocol, *See Bus hold protocol*
 Hypertext manuals and datasheets,
 downloading, 1-6

I

I/O devices
 interfacing with, 3-6–3-7
 memory-mapped, 3-6
 I/O ports
 addressing, 2-36
 I/O space, 3-1–3-7
 accessing, 3-6
 reserved locations, 2-15, 6-17
 Idle mode, 5-11–5-16, 5-16
 bus operation, 5-13
 control register, 5-12
 entering, 5-11, 5-13
 exiting, 5-14–5-15
 exiting HALT bus cycle, 3-35
 initialization code, 5-15–5-16
 Idle states
 and bus cycles, 3-18
 Immediate operands, 2-28
 IMUL instruction, A-9
 Inputs, asynchronous, synchronizing, B-1
 INS instruction, A-2
 In-Service register, 8-5, 8-7, 8-18, 8-19, 8-28
 Instruction Pointer (IP), 2-1, 2-6, 2-13, 2-23, 2-39,
 2-41
 reset status, 2-6
 Instruction prefetch bus cycle, *See Bus cycles*

Instruction set, 2-17, A-1, D-1
 additions, A-1
 arithmetic instructions, 2-19–2-20, A-9
 bit manipulation instructions, 2-21–2-22, A-9
 data transfer instructions, 2-18–2-20, A-1,
 A-8
 data types, 2-37–2-38
 enhancements, A-8
 high-level instructions, A-2
 nesting, A-2
 processor control instructions, 2-27
 program transfer instructions, 2-23–2-24
 reentrant procedures, A-2
 rotate instructions, A-10
 shift instructions, A-9
 string instructions, 2-22–2-23, A-2
 INT instruction, single-byte, *See Breakpoint
 interrupt*
 INTO instruction, 2-44
 INTA bus cycle, *See Bus cycles*
 Integer, defined, 2-37, 11-7
 Interrupt Control register, 8-28
 Interrupt Control registers, 8-12
 for external pins, 8-14, 8-15
 for internal sources, 8-13
 Interrupt Control Unit (ICU), 8-1–8-31
 block diagram, 8-2, 8-24
 cascade mode, 8-7
 initializing, 8-30, 8-31
 interfacing with an 82C59A Programmable
 Interrupt Controller, 3-25–3-27
 master mode, 8-1, 8-2–8-23
 initializing, 8-30
 operation in slave mode, 8-29
 operation with nesting, 8-4
 programming, 8-11, 8-25
 registers, 8-11, 8-25
 master mode, 8-11
 slave mode, 8-1, 8-23–8-30
 special fully nested mode, 8-8
 with cascade mode, 8-8
 without cascade mode, 8-8
 typical interrupt sequence, 8-5
 Interrupt Enable Flag (IF), 2-7, 2-9, 2-41
 Interrupt Mask register, 8-16, 8-17, 8-28
 Interrupt Request register, 8-16, 8-28
 Interrupt Status register, 8-7, 8-22, 8-23, 8-28
 Interrupt Vector register, 8-26, 8-27

Interrupt Vector Table, 2-39, 2-40

Interrupt-on-overflow trap (Type 4 exception), 2-44

Interrupts, 2-39–2-43

- and CSU initialization, 6-6
- controlling priority, 8-12
- edge- and level-sensitive, 8-10
 - and external 8259As, 8-10
- enabling cascade mode, 8-12
- enabling special fully nested mode, 8-12
- latency, 2-45
 - reducing, 3-28
- latency and response times, 8-10, 8-11, 8-30
- maskable, 2-43
- masking, 8-3, 8-12, 8-16
 - priority-based, 8-17
- multiplexed, 8-7
- nesting, 8-4
- NMI, 2-42
- nonmaskable, 2-45
- overview, 8-1, 8-2
- priority, 2-46–2-49, 8-3
 - default, 8-3
 - resolution, 8-5, 8-6
- processing, 2-39–2-42
- reserved, 2-39
- response time, 2-46
- selecting edge- or level-triggering, 8-12
- slave mode sources, 8-25
- software, 2-45
- timer interrupts, 9-16
- types, 8-9, 8-26, 8-27

See also Exceptions, Interrupt Control Unit

INTn instruction, 2-45

Invalid opcode trap (Type 6 exception), 2-44

IRET instruction, 2-41

L

Latency, *See Bus hold protocol, Direct Memory Access (DMA) Unit, Interrupts*

LEAVE instruction, A-7

Literature, ordering, 1-6

Local bus, 3-1, 3-41, 11-11

Long integer, defined, 11-7

Long real, defined, 11-7

M

Manuals, online, 1-5

Math coprocessing, 11-1

- hardware support, 11-1
- overview, 11-1

Memory

- addressing, 2-28–2-36
- operands, 2-28
- reserved locations, 2-15

Memory devices, interfacing with, 3-6–3-7

Memory segments, 2-8

- accessing, 2-5, 2-10, 2-11, 2-13
- address
 - base value, 2-10, 2-11, 2-12
 - Effective Address (EA), 2-13
 - logical, 2-10, 2-12
 - offset value, 2-10, 2-13
 - overriding, 2-11, 2-13
 - physical, 2-3, 2-10, 2-12
 - and dynamic code relocation, 2-13

Memory space, 3-1–3-6

N

Normally not-ready signal, *See Ready*

Normally ready signal, *See Ready*

Numerics coprocessor fault (Type 16 exception), 2-44, 11-13

O

ONCE mode, 12-1

One-shot, code example, 9-17–9-23

Ordinal, defined, 2-37

Oscillator

- external
 - and powerdown, 5-19
 - selecting crystal, 5-5
 - using canned, 5-6
- internal crystal, 5-1–5-10
 - controlling gating to internal clocks, 5-18
 - operation, 5-2–5-3
 - selecting C₁ and L₁ components, 5-3–5-6

OUTS instruction, A-2

Overflow Flag (OF), 2-7, 2-9, 2-44

P

Packed BCD, defined, 2-37
 Packed decimal, defined, 11-7
 Parity Flag (PF), 2-7, 2-9
 PCB Relocation Register, 4-1, 4-3, 4-6
 and math coprocessing, 11-2
 PDTMR pin, 5-18
 Peripheral Control Block (PCB), 4-1
 accessing, 4-4
 and DMA Unit, 10-3
 and F-Bus operation, 4-5
 base address, 4-6–4-7
 bus cycles, 4-4
 READY signals, 4-4
 reserved locations, 4-6
 wait states, 4-4
 Peripheral control registers, 4-1, 4-6
 Pointer, defined, 2-37
 Poll register, 8-9, 8-19, 8-20
 Poll Status register, 8-9, 8-19, 8-20, 8-21
 Polling, 8-1, 8-9
 POPA instruction, A-1
 Power consumption, reducing, 3-28, 5-23
 Power Control Register, 5-12
 Power management, 5-10–5-23
 Power management modes
 and HALT bus cycles, 3-28, 3-31
 compared, 5-23
 Powerdown mode, 5-16–5-19, 7-2
 and bus cycles, 5-16
 control register, 5-12
 entering, 5-17
 exiting, 5-18–5-19
 exiting HALT bus cycle, 3-34
 initialization code, 5-15–5-18
 Power-Save mode, 5-19–5-22, 7-2
 and DRAM refresh rate, 5-21
 and refresh interval, 7-7
 control register, 5-20
 entering, 5-19
 exiting, 5-21
 initialization code, 5-21–5-22
 Power-Save Register, 5-20
 Priority Mask register, 8-17, 8-18, 8-28
 Processor control instructions, 2-27
 Processor Status Word (PSW), 2-1, 2-7, 2-41
 bits defined, 2-7, 2-9

 flag storage formats, 2-19
 reset status, 2-7
 Program transfer instructions, 2-23–2-24
 conditional transfers, 2-24, 2-26
 interrupts, 2-26
 iteration control, 2-25
 unconditional transfers, 2-24
 PUSH instruction, A-8
 PUSHA instruction, A-1

Q

Queue status signals, 3-40

R

RCL instruction, A-10
 RCR instruction, A-10
 Read bus cycles, *See Bus cycles*
 READY
 and chip-selects, 6-15
 and normally not-ready signal, 3-17–3-18
 and normally ready signal, 3-16–3-17
 and PCB accesses, 4-4
 and wait states, 3-13–3-18
 implementation approaches, 3-13
 timing concerns, 3-17
 Real, defined, 11-7
 Real-time clock, code example, 9-17–9-20
 Refresh address, 7-4
 Refresh Base Address Register (RFBASE), 7-8
 Refresh bus cycle, *See Bus cycles*
 Refresh Clock Interval Register (RFTIME), 7-7,
 7-8
 Refresh Control Register (RFCON), 7-9, 7-10
 Refresh Control Unit (RCU), 7-1–7-13
 and bus hold protocol, 7-12–7-13
 and Powerdown mode, 7-2
 and Power-Save mode, 5-19, 7-2, 7-7
 block diagram, 7-1
 bus latency, 7-7
 calculating refresh interval, 7-7
 control registers, 7-7–7-10
 initialization code, 7-10
 operation, 7-2
 overview, 7-2–7-4
 programming, 7-7–7-11
 relationship to BIU, 7-1
 Register operands, 2-27

Registers, 2-1
 control, 2-1
 data, 2-4, 2-5
 general, 2-1, 2-4, 2-5
 H & L group, 2-4
 index, 2-5, 2-13, 2-34
 P & I group, 2-4
 pointer, 2-1, 2-5, 2-13
 pointer and index, 2-4
 segment, 2-1, 2-5, 2-11, 2-12
 status, 2-1

Relocation Register, *See PCB Relocation Register*

Reset
 and bus hold protocol, 5-6
 and clock synchronization, 5-6–5-10
 cold, 5-7, 5-8
 RC circuit for reset input, 5-7
 warm, 5-7, 5-9

ROL instruction, A-10

ROR instruction, A-10

S

SAL instruction, A-9

SAR instruction, A-9

SHL instruction, A-9

Short integer, defined, 11-7

Short real, defined, 11-7

SHR instruction, A-9

SI register, 2-1, 2-5, 2-13, 2-22, 2-23, 2-30, 2-32, 2-34

Sign Flag (SF), 2-7, 2-9

Single-step trap (Type 1 exception), 2-43

Software
 code example
 80C187 floating-point routine, 11-16
 80C187 initialization, 11-13–11-15
 digital one-shot, 9-17–9-23
 DMA initialization, 10-22–10-27
 ICU initialization, 8-31
 real-time clock, 9-17–9-19
 square-wave generator, 9-17–9-22
 TCU configurations, 9-17–9-23
 timed DMA transfers, 10-22–10-27

data types, 2-37, 2-38

dynamic code relocation, 2-13, 2-14

interrupts, 2-45

overview, 2-17

See also Addressing modes, Instruction set

Square-wave generator, code example, 9-17–9-22

SRDY, *See READY*

SS register, 2-1, 2-5, 2-6, 2-13, 2-15, 2-30, 2-45

Stack frame pointers, A-2

Stack Pointer, 2-1, 2-5, 2-13, 2-15, 2-45

Stack segment, 2-5

Stacks, 2-15

START registers, CSU, 6-6, 6-7

STOP registers, CSU, 6-6, 6-8

String instructions, 2-22–2-23
 and addressing modes, 2-34
 and memory-mapped I/O ports, 2-36
 operand locations, 2-13
 operands, 2-36

Strings
 accessing, 2-13, 2-34
 defined, 2-37

Synchronizing asynchronous inputs, B-1

T

Technical support, 1-6

Temporary real, defined, 11-7

Terminology
 "above" vs "greater", 2-26
 "below" vs "less", 2-26
 device names, 1-2

Timer Control Registers (TxCON), 9-7, 9-8

Timer Count Registers (TxCNT), 9-10

Timer Counter Unit (TCU), 9-1–9-23
 and Power-Save mode, 5-19
 application examples, 9-17–9-23
 block diagram, 9-2
 clock sources, 9-12
 configuring a digital one-shot, 9-17–9-23
 configuring a real-time clock, 9-17–9-19
 configuring a square-wave generator, 9-17–9-22
 counting sequence, 9-12–9-13
 dual maxcount mode, 9-13–9-14
 enabling and disabling counters, 9-15–9-16
 frequency, maximum, 9-17
 initializing, 9-11
 input synchronization, 9-17
 interrupts, 9-16
 overview, 9-1–9-6

- programming, 9-6–9-16
 - considerations, 9-16
- pulsed output, 9-14–9-15
- retriggering, 9-13–9-14
- setup and hold times, 9-16
- single maxcount mode, 9-13, 9-14–9-16
- timer delay, 9-1
- timing, 9-1
 - and BIU, 9-1
 - considerations, 9-16
 - TxOUT signal, 9-15
- variable duty cycle output, 9-14–9-15

Timer Maxcount Compare Registers (TxCMPA, TxCMPB), 9-11

Timers, *See Timer/Counter Unit (TCU)*

Trap exceptions, 2-43

Trap Flag (TF), 2-7, 2-9, 2-43, 2-48

T-state

- and bus cycles, 3-9
- and CLKOUT, 3-8
- defined, 3-7

W

Wait states

- and bus cycles, 3-13
- and bus ready inputs, 3-13
- and chip-selects, 6-15–6-17
- and DRAM controllers, 7-1
- and PCB accesses, 4-4
- and READY input, 3-13

Word integer, defined, 11-7

World Wide Web, 1-6

Write bus cycle, 3-22

Z

Zero Flag (ZF), 2-7, 2-9, 2-23